

A. W. KINDEL.
 APPARATUS FOR FORMING ROLL EDGES ON MATTRESSES.
 APPLICATION FILED FEB. 1, 1911.

1,013,401.

Patented Jan. 2, 1912.

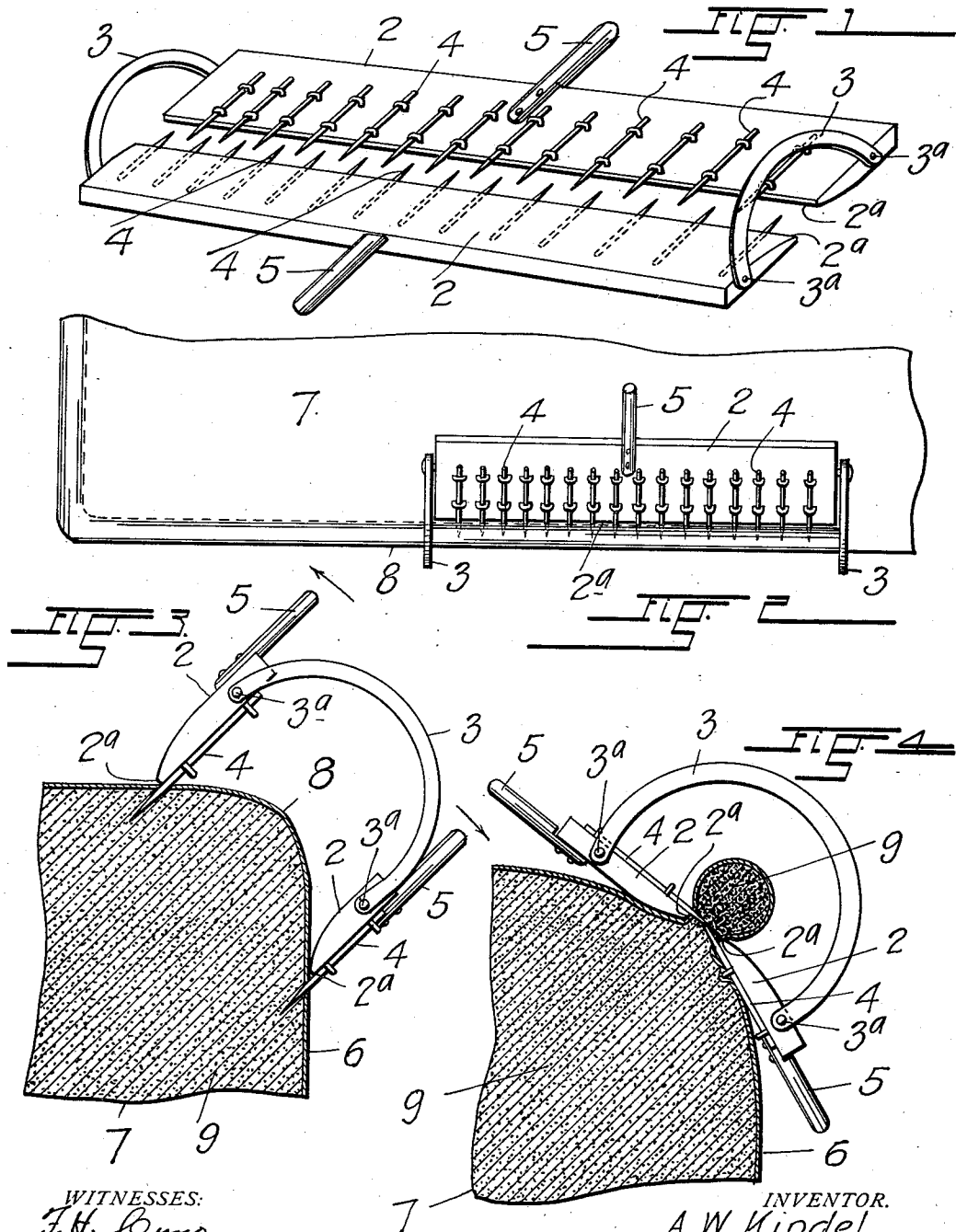

WITNESSES:
F. H. Guno
L. Roadie

INVENTOR.
 A. W. Kindel

BY *[Signature]*
 ATTORNEY.

UNITED STATES PATENT OFFICE.

ARTHUR W. KINDEL, OF DENVER, COLORADO.

APPARATUS FOR FORMING ROLL EDGES ON MATTRESSES.

1,013,401.

Specification of Letters Patent.

Patented Jan. 2, 1912.

Application filed February 1, 1911. Serial No. 605,994.

To all whom it may concern:

Be it known that I, ARTHUR W. KINDEL, a citizen of the United States, residing at 1115 Cook street, Denver, in the county of Denver and State of Colorado, have invented certain new and useful Improvements in Apparatus for Forming Roll Edges on Mattresses, of which the following is a specification.

This invention relates to an apparatus for producing roll-edges on mattresses and its object resides in the provision of a device of simple construction by the use of which the method of forming roll-edges described in the application for patent Serial Number 605,995 filed synchronously with the present one, may be carried into effect.

An embodiment of my invention is illustrated in the accompanying drawings in the various views of which like parts are similarly designated and in which—

Figure 1 represents a perspective view of the apparatus, Fig. 2, a plan view of a portion of a mattress with the device in its operative position, and Figs. 3 and 4, fragmentary cross-sectional views of the mattress showing the apparatus in two of the positions it occupies while the method of producing the roll-edge is being practiced.

Referring to the drawings by numerals, 2 designates two straight-edged bars of wood which in the operation, constitute levers fulcrumed to turn about longitudinal axes between and at opposite ends of two curved yokes 3, with which they are pivotally connected by means of pins 3^a inserted into their respective ends. The bars 2 which, preferably, are tapered toward their rectilinear edges 2^a are each provided with a series of transversely arranged, slender instruments 4, the sharp pointed extremities of which project beyond the said edges. The needles 4 on each of the two bars alternate with the spaces between those on the other so that the instruments comprised in the two series may pass each other when the bars are turned in about their pivotal axes. Each of the bars 2 is furthermore provided with an outwardly extending handle 5 which facilitates their manipulation and increases this leverage.

In the operation of my invention, the points of the two series of needles connected with the respective bars, are inserted into the cover 6 of a mattress 7 along parallel lines at opposite sides of an edge 8 of

the same, in the manner shown in Fig. 3 of the drawings. The bars 2 are then turned in opposite directions about their axes of rotation, between the yokes 3, until their faces are brought in engagement with the respective surfaces of the mattresses as illustrated in Fig. 4. When the bars are in this position, they extend nearly in one plane and by engagement of their straight edges 2^a with the interposed portion of the mattress, oppose each other's rotary movement and thus hold the parts in position until released by movement of the bars about their axes in the opposite directions. During the rotary movement of the members 2 in the directions of the arrows in Fig. 3, a portion of the stuffing 9 of the mattress, is by means of the instruments 4, forced toward the edge 8 of the same and the portion of the cover 7 engaged by the rectilinear edges 2^a of the two bars are at the same time drawn together along the lines determined by the said edges. When the parts are thus temporarily secured as shown in Fig. 4, the portions of the cover at opposite sides of the edge 8, are fastened together along the line of contraction determined by the straight edges 2^a of the bars 2, by stitching or sewing with twine or other suitable material. The stuffing which by the movement of the needles 4, was compressed in the portion of the cover between the edge 8 and the line of contraction, is thus permanently confined therein and the roll-edge thus produced will, after the apparatus has been removed by rotating the levers in the opposite directions, be firm, of uniform compactness and of equal width.

Having thus described my invention what I claim and desire to secure by Letters-Patent is:—

1. An apparatus for forming roll-edges on mattresses comprising in combination, two coöperative, rotatory members having parallel edges constructed to draw and clamp the cover of a mattress together along lines at opposite sides of an edge thereof, and means carried by said members and projecting beyond the edges thereof to compress the stuffing of the mattress within the portion of its cover between said lines and said edge during and by the rotary movement of said members.

2. An apparatus for forming roll-edges on mattresses comprising a pair of coöperative

levers mounted to rotate about parallel axes, and each having a straight edge parallel to its axis of rotation, and series of slender pointed instruments carried by and projecting transversely beyond the respective straight edges, the said levers being so disposed and proportioned that by engagement of their straight edges with the cover of a mattress at opposite sides of an edge thereof, they will when simultaneously rotated draw the said engaged portions together to a distance suitable for the sewing required in the production of a roll edge.

3. An apparatus for forming roll edges on mattresses comprising two yokes, cooperative members rotatable about parallel axes between said yokes, and each having a straight edge parallel to its axis of rotation, and series of slender pointed instruments carried by and projecting transversely beyond the respective straight edges, the said levers being so disposed and proportioned that by engagement of their straight edges with the cover of a mattress at opposite sides of an edge thereof they will when simultaneously rotated draw the said engaged portions

together to a distance suitable for the sewing required in the production of a roll edge.

4. An apparatus for forming roll-edges on mattresses, comprising two yokes, cooperative members rotatable about parallel axes between said yokes, and each having a straight edge parallel to its axis of rotation, and series of slender instruments, pointed extremities of which project transversely beyond the respective straight edges, the said levers being so disposed and proportioned that by engagement of their straight edges with the cover of a mattress at opposite sides of an edge thereof they will when simultaneously rotated draw the said engaged portions together to a distance suitable for sewing, and the said yokes being curved to admit the roll edge formed by the contraction of said cover substantially as described.

In testimony whereof I have affixed my signature in presence of two witnesses.

* ARTHUR W. KINDEL.

Witnesses:

L. RHOADES,
G. J. ROLLANDET.

Copies of this patent may be obtained for five cents each, by addressing the "Commissioner of Patents, Washington, D. C."