



(11) **EP 3 597 169 B1**

(12) **EUROPEAN PATENT SPECIFICATION**

(45) Date of publication and mention of the grant of the patent:
14.07.2021 Bulletin 2021/28

(51) Int Cl.:
A61H 33/06^(2006.01) E04H 1/12^(2006.01)

(21) Application number: **18184112.3**

(22) Date of filing: **18.07.2018**

(54) **SAUNA**

SAUNA

SAUNA

(84) Designated Contracting States:
AL AT BE BG CH CY CZ DE DK EE ES FI FR GB GR HR HU IE IS IT LI LT LU LV MC MK MT NL NO PL PT RO RS SE SI SK SM TR

(43) Date of publication of application:
22.01.2020 Bulletin 2020/04

(73) Proprietor: **Ripavi Oy**
02760 Espoo (FI)

(72) Inventors:
• **Koivisto, Juha**
02760 Espoo (FI)

• **Kuikka, Marko**
01760 Vantaa (FI)

(74) Representative: **LEITZINGER OY**
Tammasaarekatu 1
00180 Helsinki (FI)

(56) References cited:
DE-A1-102013 108 990 DE-U1- 20 021 424
DE-U1-202013 104 063 KR-A- 20100 130 373
RU-U1- 46 417

EP 3 597 169 B1

Note: Within nine months of the publication of the mention of the grant of the European patent in the European Patent Bulletin, any person may give notice to the European Patent Office of opposition to that patent, in accordance with the Implementing Regulations. Notice of opposition shall not be deemed to have been filed until the opposition fee has been paid. (Art. 99(1) European Patent Convention).

Description

Background of the invention

5 [0001] The invention relates to a sauna according to the preamble of the appended independent claim.
[0002] Nowadays especially transportable saunas have increased their popularity. They are compact, usually smaller than saunas which are built on site, separate from the building, transportable and devoted to sauna use.
[0003] There are, however, problems associated with known transportable saunas. For example, it may be laborious to use them because often transportable saunas need to be completely disassembled for transport and re-assembled on site. Known transportable saunas may also have structural problems. For example, wall structures in saunas may be weak or they do not function sufficiently in cold weather conditions, for example in winter, often requiring thermal insulation between the outer wall and the interior wall structures. Still another problem associated with previously known saunas is also that they often require fairly planar soil for sauna use and sauna installation. If the sauna is installed in an oblique position due to uneven ground, it may cause water to build up inside the sauna and water and moisture damage.
15 [0004] Examples of prior art solutions are disclosed in DE 20021424 U1, RU 46417 U1, DE 202013104063 U1, KR 1020100130373 A, DE 102013108990 A1. As discussed above, structural problems limit the use of the saunas disclosed in these publications.

Brief description of the invention

20 [0005] The object of the invention is therefore to provide a sauna that can solve the above problems. The object of the invention is achieved by a sauna, which is characterized by what is stated in the independent claims. Preferred embodiments of the invention are disclosed in the dependent claims.
[0006] The present the invention is based on the idea of a transportable sauna having a separate prefabricated wooden frame and a separate leg arrangement with height adjustment. Height adjustment allows the use of the sauna on uneven surfaces, such as a yard, campsite, terrain, lake or sea, or in the snow. The frame may be adjusted to the desired height and position. The advantage of detachability is that the sauna is quickly arranged for sauna use or transportation. The size of the sauna is dimensioned so that the sauna can be transported to the user in the sea container as prefabricated without fully dismantling the frame. The advantage of the sauna according to the invention is also the load bearing structure of the frame. A frame being made of cross laminated timber makes it possible that no isolation on wooden elements and floor surfaces is needed in order to take into account the temperature changes.
30

Brief description of the drawings

35 [0007] The invention will now be described in more detail with reference to the preferred embodiments and with reference to the accompanying drawings in which:

- Figure 1 is a perspective view of a sauna according to an embodiment of the present invention;
- 40 Figures 2a and 2b show a frame according to embodiments of the present invention;
- Figure 3 shows a base element according to an embodiment of the present invention;
- Figure 4 shows a drainage system according to an embodiment of the present invention;
- 45 Figure 5 shows a leg according to an embodiment of the present invention;
- Figures 6a and 6b show an engagement means according to an embodiment of the present invention;
- 50 Figure 7a is a view of a pontoon arrangement according to an embodiment of the present invention;
- Figure 7b is a view of a sauna according to an embodiment of the present invention.

Detailed description of the invention

55 [0008] The present invention will be described below with reference to the accompanying drawings showing preferred embodiments of the invention. The present invention can be implemented in many different forms and should not be construed as being limited to the embodiments described herein.

[0009] FIG. 1 is a perspective view of a sauna according to an embodiment of the present invention. The sauna according to an embodiment comprises two separate sections, a prefabricated wooden frame 100 and an adjustable leg arrangement 200. The frame is preferably made of cross-laminated wood elements, that is, cross-laminated timber (CLT), a wood panel product made of glued lumber layers together. In an embodiment, the shape of the frame is consisting of six wooden wall elements joined to each other at their edges, defining an interior of the sauna. In an embodiment, the sauna has a door, windows, sauna benches and a heater arranged therein. The frame is a load-bearing structure designed to carry the weight of above elements and to distribute loads down to the foundations. The frame is mounted on an adjustable, and detachable, leg arrangement 200 comprising four height adjustable legs 1, each having a crank 2 or the like coupled to them. The legs are made of metal, such as steel.

[0010] In an embodiment shown in FIG. 1, the legs are arranged at a distance from the outer surfaces of the side walls in pairs in opposite outer edges of the frame so that the upper end of each leg is supported against the outer surface of the side wall. The lower end of each leg is supported against the installation surface, such as concrete slabs. The legs may be freely adjustable in parallel with planar surfaces of the side wall elements. The legs may be adjusted, for example vertically, allowing the frame to be moved, raised and lowered, when one or more of the cranks are rotated. Underneath the frame there are no obstructions that would hinder the frame from lowering down to the installation surface level, such as ground or concrete slabs.

[0011] FIGS. 2a and 2b show a frame according to an embodiment of the present invention. Frame consists of roof element 3, base element 4 and four sidewall elements extending between the base element and the roof element. The elements are arranged so that they define an interior of the sauna. The side wall elements include a first side wall element 5, a second side wall element 6, a front side wall element 7, and a rear side wall element (not shown in FIGS. 2a, 2b). Each of the said elements used in the frame is substantially rectangular. The frame is advantageously prefabricated so that no special skills are required by the users for commissioning the sauna. All the elements are made of cross-laminated wood. The elements are fastened to each other at their edges and/or their plane surfaces using fastening means, for example, double threaded screws. The distance between the screws may be 300 millimeters, for example. In an embodiment, the sauna interior may comprise one or more rooms, for example, a sauna room, a bath room, a shower room, a changing room and/or a lounge room. The rooms may be divided by partition walls. The sauna may be equipped with a variety of optional equipment such as shower, storage facilities, sunroof, pump, lighting fixtures, water heater, benches, veranda, gray water filter, ventilation valves, glass or wooden partitions, audio / video equipment, telecommunication connections, outboard motors, solar panels, and / or electrical connections.

[0012] In an embodiment, the frame is equipped with a mono-pitched roof. The roof element 3 is arranged in an inclined position, having a single slope, the side wall elements being provided with sloping recesses on which the roof element is attached. The roof element may be coated with metal roofing. In addition to the roof element, the end edges of the adjacent sidewall elements may be coated metal roofing. The roof and base elements and/or the side wall elements may also be provided with a chimney and/or vent holes.

[0013] According to an embodiment of the present invention, the elements may be provided with one or more windows. Referring to FIGS. 1, 2a and 2b, the first and second side wall elements, the roof element and the front side wall element are provided with windows 8-11. Also the base element may be provided with one or more windows. The front side wall element is provided with a door opening 12 and a door (not shown in FIGS.). The door can be a wooden door or a glass door. The frame may be further provided with an open covered space, for example a veranda, which may, for example, have a shower or a pump.

[0014] According to an embodiment of the present invention, the sauna is provided with one or more lifting hooks. Referring to FIG. 2a, the side wall element is provided with two lifting points 13 reinforced with built-in metal parts. The lifting points are preferably arranged in the upper part of the side wall element. Lifting hooks can be made of metal, for example steel. Preferably, there are at least four lifting hooks and four lifting points for each frame. Fastening of lifting hooks can be made, for example, by screwing. When the sauna is to be transported or need to be lifted, the lifting hooks are first screwed into the lifting points. The leg arrangement can then be detached when the sauna lifted.

[0015] FIG. 3 shows a base element according to an embodiment of the present invention. The base element is substantially rectangular. It has a floor surface 14 and an outer surface, as well as the edges 15. The base element is made of cross laminated wood and has a thickness of preferably 120 mm. The base element is a load-bearing structure. According to an embodiment of the invention the floor is an integral part of the base element. The floor surface is sloping. The highest points on the floor are near the edges of the floor and the lowest points on the floor are near the center of the floor having a first recess 16. The floor slope can be about one or two centimeters per one meter, for example 2 cm/m. The first recess is provided with a built-in drainage system, which is shown in FIG. 4. The base element has an opening through the base element through which water is removed. The base element opening has a diameter of about 50 millimeters (not shown in FIG. 3). The slope of the floor surface of the base element ensures water drainage each time to avoid water buildup that otherwise can cause water damage.

[0016] FIG. 4 shows a drainage system according to an embodiment of the present invention. A drainage system 300 comprising a floor drain element 17 having one or more inlets 18 and outlet openings 19 and at least one perforated

plate 20. The drainage system is arranged in a first recess 16 on the floor surface 14. The drainage system may be made of metal, for example steel or aluminum. It may also be made of plastic. In an embodiment, the drainage system has a length of 2040 millimeters and a width of 105 millimeters. The drainage system has a thickness of about 20 mm. The outlet aperture is 150 mm long and has a diameter of about 50 mm. Further, an outlet can be provided with a gray water filter, a water and/or drain pipe and/or a special pipe connection for example for two pipes. The outlet is disposed so that the water flowing along the sloped floor is preferably collected first into the drainage system and removed then through the outlet of the drainage system.

[0017] The base element thicknesses range from 70 to 300 millimeters. The thickness is advantageously 120 millimeters. The thickness of the roof element and the plurality of side wall elements are in the range of 70 to 300 millimeters, preferably 90 millimeters. The width of the sauna body is for example 2260 millimeters. The height of the frame may be, for example, 2500 millimeters. The frame length may vary between 2900 and 4000 millimeters. With respect to its dimensions, the frame of the sauna fits into a sea container, for transportation, since the sea container has an interior width of about 2340-2360 millimeters.

[0018] FIG. 5 shows a leg according to an embodiment of the present invention. According to an embodiment of the present invention, the adjustable leg arrangement comprises a plurality of legs. For example, the large frame may have six adjustable legs, and a small frame may have four adjustable legs. Referring to FIG. 5, the leg 400 is provided with a stationary portion 21 and a movable portion 22. The movable portion is further provided with lower end 47. The stationary portion of each leg is further provided with an elongated connector 23 for attaching the leg. An elongated connector is further provided with a first opening 24 and a quick release pin 25. The diameter of the quick release pin is preferably smaller than the diameter of the first opening. The stationary portion has a counterpart 26 through which the leg is supported on the outer surface of the side wall element. The length of the counterpart may be, for example, between 10 and 80 millimeters. The counterpart prevents the leg from swinging and twisting. The leg may be made of metal, such as steel or aluminum. Each adjustable leg may have a carrying capacity of between 1000 and 4000 kilograms, for example between 1300 and 1400 kilograms. The stationary portion and the movable portion are arranged in the leg such that the said portions can be moved telescopically relative to each other. According to an embodiment, the legs are of a straight and/or elongated shape. The leg has an actuator, for example a crank 32. The actuator is operatively coupled to the movable portion so that the actuator can adjust the distance, for example, the height (or length), between the stationary portion and the movable portion. The actuator can be, for example, a crank, handle or electrically powered device which may be permanently or detachably attached to the leg.

[0019] When the actuator is used, for example, when the crank is rotated, the movable portion moves either towards the stationary portion or away from the stationary portion. The direction of motion depends on the direction in which the actuator, such as crank, is rotated. Using the actuator causes the height of the leg associated with the actuator to change. When the leg is attached to the frame adjusting allows the frame to move in two opposing directions, for example upwards and downwards. Each leg is independently adjustable in a predetermined adjustment range, for example 10 to 100 centimeters or for example 0 to 40 centimeters.

[0020] FIGS. 6a and 6b show an engagement means according to an embodiment of the present invention. According to an embodiment of the present invention, the adjustable leg arrangement comprises a plurality of engagement means. Number of engagements means is for example 4 or 6. Referring to FIGS. 6a and 6b, the engagement means 500 is an L-shaped plate having a sliding portion 27 on the first side and a support portion 28 on the second side. The sliding portion is provided with a groove 29. The upper end of the sliding portion is provided with a limiter 30 which restricts the sliding movement in the sliding portion. The lower end of the sliding portion is provided with a second opening 31. The engagement means may be made of metal such as steel or aluminum. The engagement means is arranged on the frame so that the sliding portion and the groove open outwardly from the frame and are essentially parallel to the plane surface of the plurality of side wall elements. The support portion of the coupling means is supported on the frame from two directions, the outer surface of the base element, and the outer surface of the side wall element. The engagement means are attached to the frame by using conventional fastening means, for example with screws.

[0021] According to an embodiment of the present invention, the plurality of engagement means and the plurality of legs are separate parts and the said legs are connected to the frame by the plurality of engagement means. The number of engagement means is for example 4 or 6. The leg is attached to the frame so that the leg is brought below the engagement means and the elongated connector is aligned with the groove 29. The leg slides into the groove 29 by pushing it upwards. When the leg is inserted into the engagement means, it is limited to the limiter 30. The quick release pin 25 is then pushed through the first and second openings, whereby the leg is locked with the quick release pin in its position and cannot detach. The upper end of the leg is supported against the planar outer surface of the side wall element via the counterpart 26. The lower end 47 of the movable portion of the leg is positioned against the surface on which the height-adjustable leg arrangement is installed. When the leg needs to be removed, the quick release pin is first removed from the first and second openings, after which the leg is slid downwardly along the groove until the leg releases.

[0022] According to an embodiment of the invention, the plurality of legs is arranged at a distance from the plurality

of side wall elements. The legs are adapted to the frame so that the frame can be lowered to the level of lower edge of the movable portion. The advantage is that underside of the base element can then be lowered against the installation surface, for example soil, concrete foundation, or concrete slabs. This is accomplished according to an embodiment such that the stationary portion of the leg is arranged to the frame so that the stationary portion is positioned above the base element. In addition, the movable portion is adapted to move relative to the stationary portion so that it can protrude essentially completely into the said stationary portion.

[0023] FIG. 7a is a view of a pontoon arrangement according to an embodiment of the present invention. According to an embodiment on the present invention, the sauna comprises one or more pontoons or pontoon arrangements having multiple pontoons interconnected by a metal body or the like and that said pontoon arrangement is adapted to be mounted on said adjustable leg arrangement. The pontoons may be attached to the lower end of the movable portion, for example by bolts and nuts. This allows the sauna to be used as a floating sauna in the water, such as on lake or sea.

[0024] In the following the above mentioned pontoon arrangement is explained more specifically. Referring to FIG. 7a, each pontoon arrangement comprises five pontoons each of which has a cylindrical shape. Each pontoon arrangement may be consisted of a first pontoon 33, a second pontoon 34, a third pontoon 35, a fourth pontoon 36 and a fifth pontoon 37. Each pontoon has floating properties with water. These five pontoons are arranged in parallel, and in rows. At least one first metal rod 38 is located above each pontoon in the longitudinal direction of the pontoon. The pontoon is attached to the first metal rod above it, for example, with metal strips 39. Each pontoon may have at least two metal strips. The metal strips are arranged at opposite ends of the first metal rod so that each metal strip rotates around the pontoon. The direction of rotation is substantially perpendicular to the length of the pontoon. The metal strips attach the pontoon to the first metal rod attached thereto. Other attachment methods can be used, for example, glue, screws or bolts.

[0025] Above each of the first metal rods, there are one or more second metal rods 40. The second metal rods are disposed parallel to one another and spaced apart from each other. The second metal rods are preferably arranged perpendicularly to the longitudinal direction of the first metal rods. The second metal rods are arranged over the pontoons so that they connect the said five pontoons together through the first metal rods. The second metal rods fastened with the first metal rods by means of conventional fastening means, for example by welding, screws or bolts. Therefore, the aforementioned plurality of first metal rods and a plurality of second metal rods together form a structure of a metal body or the like.

[0026] Referring to FIG. 7a, between the first pontoon 33 and the second pontoon 34 there is provided a first metal plate 41 attached to the second metal rods. In addition, between the fourth pontoon 36 and the fifth pontoon 37 there is provided a second metal plate 42 attached to the second metal rods. The said first metal plate and the second metal plate are spaced apart. The first and second metal plates are positioned so that the distance between their vertical center points is substantially equal to the distance between a pair of the adjustable legs.

[0027] An adjustable leg 43, having a lower end, is provided for each metal plate, and fastened to the center of the metal plate through the said lower end. Thus, each pontoon arrangement may comprise at least two adjustable legs and at least two metal plates. In addition, at least two pontoon arrangements can be connected to each frame.

[0028] FIG. 7b is a view of a sauna arrangement according to an embodiment of the present invention. In FIG. 7b, there are two pontoon arrangements 44, each of them having five pontoons. The both pontoon arrangements are adapted to be attached to the frame 45 via an adjustable leg arrangement 46. This is preferably done by placing the pontoon arrangements, as shown in FIG. 7a, under the leg arrangement in succession. In this case, the longer sides of each cylindrical pontoon point towards the first and second side wall elements. Similarly, the shorter sides of each pontoon point toward the front side wall element and the rear side wall element. According to an embodiment on the present invention, the sauna comprises one or more ski or ski arrangements having multiple pontoons interconnected by a metal body or the like and that said ski arrangement is adapted to be mounted on said adjustable leg arrangement. This allows the use of the sauna in the snow.

[0029] It is obvious to a person skilled in the art that, as technology advances, the inventive concept can be implemented in various ways. The invention and its embodiments are thus not limited to the examples described above but may vary within the scope of the claims.

Claims

1. A sauna, comprising:

a wooden frame (45, 100) consisting of a roof element (3), a base element (4) and a plurality of side wall elements (5, 6, 7), the interior being defined by the said elements joined to one another at their edges, having one or more doors arranged at least at one of the said elements, and sauna benches and a heater,

characterized in that the frame (45, 100) is a load bearing structure, the elements of the said frame being made of cross laminated timber, and that the sauna comprises an adjustable and detachable leg arrangement

(200) on which the frame (45, 100) is mounted, said leg arrangement (200) having a plurality of adjustable legs (1, 400) being arranged at a distance from the plurality of the side wall elements (5, 6, 7), such that there are no obstructions that would hinder the frame from lowering down to an installation surface level, such as ground or concrete slabs, and a plurality of actuators (2, 32) operatively coupled to the plurality of legs, and being arranged to move said frame in opposite first and second directions.

2. A sauna according to claim 1, **characterized in that** the plurality of legs (200) being configured to telescopically change their length/height when one or more of the plurality of actuators (2, 32) is operated.
3. A sauna according to claim 1, **characterized in that** a plurality of actuators (2, 32) are adapted to move the frame (45, 100) in the opposite first and second directions when one or more of the plurality of actuators (2, 32) is operated.
4. A sauna according to claim 1, **characterized in that** the frame (45, 100) and the plurality of legs (1, 400) are separate parts which are connected to each other by the plurality of engagement means (500).
5. A sauna according to claim 1, **characterized in that** the upper end of the plurality of legs (1, 400) being supported against the outer surface of plurality of the side wall elements (5, 6, 7).
6. A sauna according to claim 1, **characterized in that** the plurality of legs (1, 400) are arranged in pairs in opposite outer edges of the base element (4) so that the upper end of each leg is supported on the outer surface of the side wall element (5, 6, 7).
7. A sauna according to claim 1, **characterized in that** the floor is an integral part of a base element (4) having an inclined floor surface (14) and that the floor is provided with a built-in drainage system (300).
8. A sauna according to claim 1, **characterized in that** the sauna is provided with a lifting means (13), such as a hook, for lifting the sauna.
9. A sauna according to claim 1, **characterized in that** the sauna comprises a shower or a shower room.
10. A sauna according to claim 1, **characterized in that** the sauna comprises one or more pontoons or pontoon arrangements (44) having multiple pontoons interconnected by a metal body and that said pontoon arrangement is adapted to be mounted on said adjustable leg arrangement (200).
11. A sauna according to claim 1, **characterized in that** the sauna comprises one or more ski or ski arrangements having multiple skis interconnected by a metal body and that said ski arrangement is adapted to be mounted on said adjustable leg arrangement.
12. A sauna according to claim 1, **characterized in that** the sauna comprises one or more rooms divided by partition walls.

Patentansprüche

1. Sauna, umfassend:
einen Holzrahmen (45, 100), bestehend aus einem Dachelement (3), einem Bodenelement (4) und mehreren Seitenwandelementen (5, 6, 7), wobei der Innenraum durch die Elemente, die an ihren Rändern miteinander verbunden sind, definiert wird, mit einer oder mehreren Türen, die an mindestens einem der Elemente angeordnet sind, und Saunabänken und einem Ofen, **dadurch gekennzeichnet, dass** der Rahmen (45, 100) ein Traggestell ist, wobei die Elemente des Rahmens aus Brettsperholz hergestellt sind, und dass die Sauna eine verstellbare und abnehmbare Ständeranordnung (200) umfasst, an der der Rahmen (45, 100) montiert ist, wobei die Ständeranordnung (200) mehrere einstellbare Ständer (1, 400) aufweist, die in einem Abstand von den mehreren Seitenwandelementen (5, 6, 7) angeordnet sind, so dass es keine Hindernisse gibt, die ein Absenken des Rahmens auf ein Installationsoberflächenniveau, wie etwa den Boden oder Betonplatten, behindern würden, und mehrere Betätigungselemente (2, 32), die betriebsmäßig mit den mehreren Ständern gekoppelt und so angeordnet sind, dass sie den Rahmen in entgegengesetzte erste und zweite Richtungen bewegen.
2. Sauna nach Anspruch 1, **dadurch gekennzeichnet, dass** die mehreren Ständer (200) so konfiguriert sind, dass sie ihre Länge/Höhe teleskopisch ändern, wenn ein oder mehrere der mehreren Betätigungselemente (2, 32) betätigt

werden.

- 5 3. Sauna nach Anspruch 1, **dadurch gekennzeichnet, dass** mehrere Betätigungselemente (2, 32) dazu angepasst sind, den Rahmen (45, 100) in die entgegengesetzten ersten und zweiten Richtungen zu bewegen, wenn ein oder mehrere der mehreren Betätigungselemente (2, 32) betätigt werden.
- 10 4. Sauna nach Anspruch 1, **dadurch gekennzeichnet, dass** der Rahmen (45, 100) und die mehreren Ständer (1, 400) separate Teile sind, die durch die mehreren Eingriffsmittel (500) miteinander verbunden sind.
- 15 5. Sauna nach Anspruch 1, **dadurch gekennzeichnet, dass** das obere Ende der mehreren Ständer (1, 400) gegen die Außenfläche der mehreren Seitenwandelemente (5, 6, 7) abgestützt ist.
- 20 6. Sauna nach Anspruch 1, **dadurch gekennzeichnet, dass** die mehreren Schenkel (1, 400) paarweise an gegenüberliegenden Außenkanten des Bodenelements (4) angeordnet sind, so dass das obere Ende jedes Ständers an der Außenfläche des Seitenwandelementes (5, 6, 7) abgestützt ist.
- 25 7. Sauna nach Anspruch 1, **dadurch gekennzeichnet, dass** der Boden ein integraler Bestandteil eines Bodenelements (4) mit einer geeigneten Bodenfläche (14) ist und dass der Boden mit einem eingebauten Drainagesystem (300) versehen ist.
- 30 8. Sauna nach Anspruch 1, **dadurch gekennzeichnet, dass** die Sauna mit einem Hebemittel (13), wie einem Haken, zum Anheben der Sauna versehen ist.
- 35 9. Sauna nach Anspruch 1, **dadurch gekennzeichnet, dass** die Sauna eine Dusche oder einen Dushraum umfasst.
- 40 10. Sauna nach Anspruch 1, **dadurch gekennzeichnet, dass** die Sauna einen oder mehrere Pontons oder Pontonanordnungen (44) umfasst, die mehrere durch einen Metallkörper miteinander verbundene Pontons aufweisen, und dass die Pontonanordnung geeignet ist, an der verstellbaren Ständeranordnung (200) angebracht zu werden.
- 45 11. Sauna nach Anspruch 1, **dadurch gekennzeichnet, dass** die Sauna einen oder mehrere Ski oder Skianordnungen mit mehreren Skis umfasst, die durch einen Metallkörper miteinander verbunden sind, und dass die Skianordnung geeignet ist, an der verstellbaren Ständeranordnung angebracht zu werden.
- 50 12. Sauna nach Anspruch 1, **dadurch gekennzeichnet, dass** die Sauna einen oder mehrere durch Trennwände unterteilte Räume umfasst.

Revendications

- 40 1. Sauna comprenant :
- 45 un cadre en bois (45, 100) comprenant un élément de toit (3), un élément de base (4) et une pluralité d'éléments de paroi latérale (5, 6, 7), l'intérieur étant défini par lesdits éléments reliés les uns aux autres par leurs bords, présentant une ou plusieurs portes disposées au moins au niveau de l'un desdits éléments, et des bancs de sauna ainsi qu'un moyen de chauffage,
- 50 **caractérisé en ce que** le cadre (45, 100) est une structure de support de charge, les éléments dudit cadre étant constitués de bois contrecollé, et **en ce que** le sauna comprend un ensemble de pieds (200) réglables et détachables sur lequel est monté le cadre (45, 100), ledit ensemble de pieds (200) comportant une pluralité de pieds réglables (1, 400) disposés à une distance de la pluralité d'éléments de paroi latérale (5, 6, 7), de sorte qu'aucune obstruction ne peut empêcher le cadre de s'abaisser à un niveau de surface d'installation, tel que le plancher ou des dalles de béton, ainsi qu'une pluralité d'actionneurs (2, 32) accouplés fonctionnellement à la pluralité de pieds, tout en étant conçus pour déplacer ledit cadre dans des première et deuxième directions opposées.
- 55 2. Sauna selon la revendication 1, **caractérisé en ce que** la pluralité de pieds (200) sont configurés pour modifier leur longueur/hauteur de façon télescopique lorsqu'un ou plusieurs de la pluralité d'actionneurs (2, 32) est/sont activé(s) .
3. Sauna selon la revendication 1, **caractérisé en ce qu'**une pluralité d'actionneurs (2, 32) sont adaptés pour déplacer

EP 3 597 169 B1

le cadre (45, 100) dans des première et deuxième directions opposées lorsqu'un ou plusieurs de la pluralité d'actionneurs (2, 32) est/sont activé(s).

- 5 4. Sauna selon la revendication 1, **caractérisé en ce que** le cadre (45, 100) et la pluralité de pieds (1, 400) sont des pièces séparées reliées les unes aux autres par la pluralité de moyens d'engagement (500).
5. Sauna selon la revendication 1, **caractérisé en ce que** l'extrémité supérieure de la pluralité de pieds (1, 400) s'appuie contre la surface extérieure de la pluralité d'éléments de paroi latérale (5, 6, 7).
- 10 6. Sauna selon la revendication 1, **caractérisé en ce que** la pluralité de pieds (1, 400) sont disposées en paires dans des bords extérieurs opposés de l'élément de base (4), de sorte que l'extrémité supérieure de chaque pied s'appuie sur la surface extérieure de l'élément de paroi latérale (5, 6, 7) .
- 15 7. Sauna selon la revendication 1, **caractérisé en ce que** le plancher fait partie intégrante d'un élément de base (4) présentant une surface de plancher inclinée (14) et **en ce que** la plancher est doté d'un système de drainage incorporé (300) .
- 20 8. Sauna selon la revendication 1, **caractérisé en ce que** le sauna est doté d'un moyen de soulèvement (13), tel qu'un crochet, destiné à soulever le sauna.
- 25 9. Sauna selon la revendication 1, **caractérisé en ce que** le sauna comprend une douche ou une cabine de douche.
- 30 10. Sauna selon la revendication 1, **caractérisé en ce que** le sauna comprend un ou plusieurs pontons ou ensembles de pontons (44) présentant une multitude de pontons reliés entre eux par un corps métallique et **en ce que** ledit ensemble de pontons est adapté pour être monté sur ledit ensemble de pieds réglables (200).
- 35 11. Sauna selon la revendication 1, **caractérisé en ce que** le sauna comprend un ou plusieurs skis ou ensembles de skis reliés entre eux par un corps métallique et **en ce que** ledit ensemble de skis est adapté pour être monté sur ledit ensemble de pieds réglables.
- 40 12. Sauna selon la revendication 1, **caractérisé en ce que** le sauna comprend une ou plusieurs pièces séparées par des cloisons.
- 45
- 50
- 55

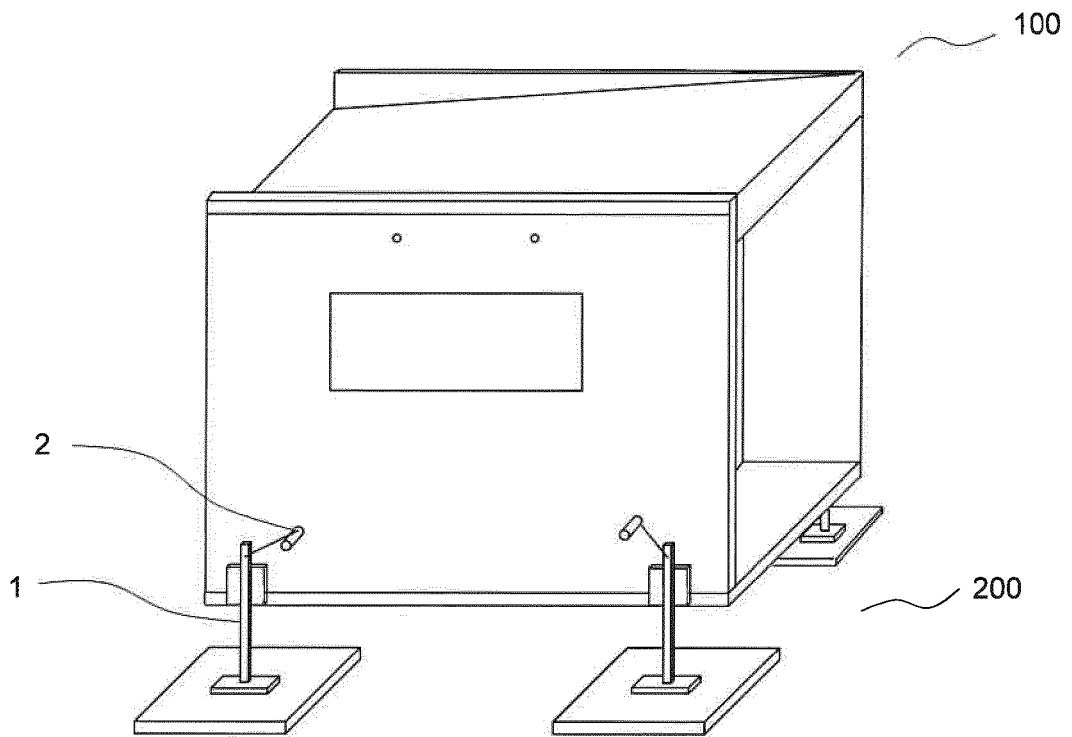

Fig. 1

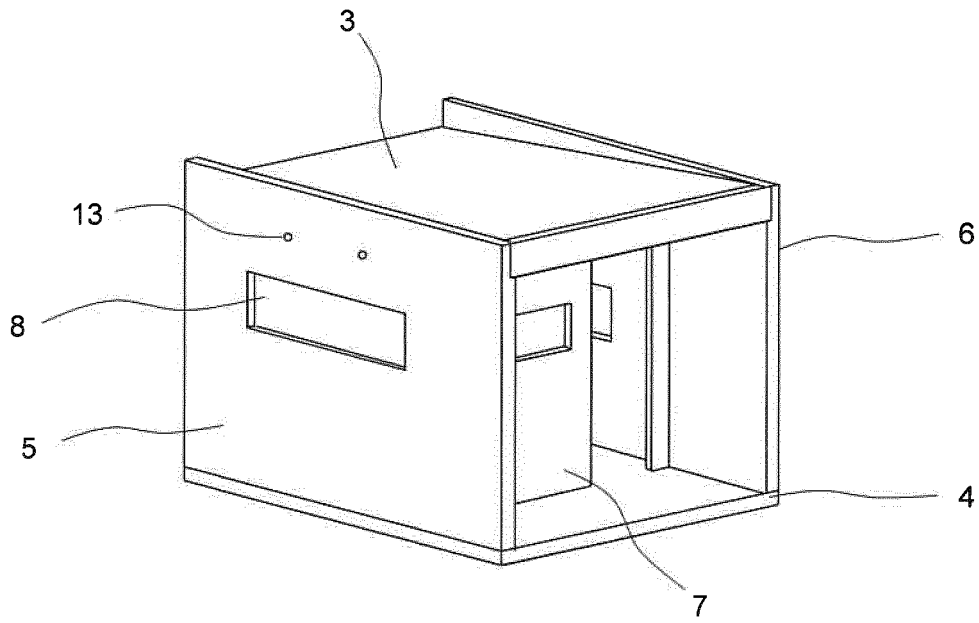

Fig. 2a

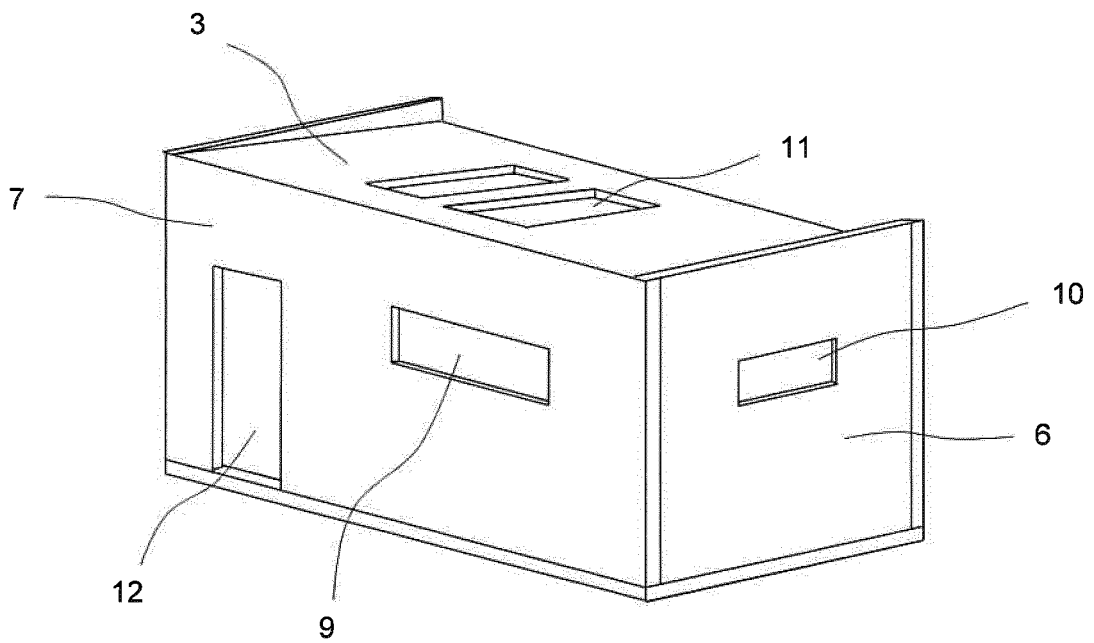

Fig. 2b

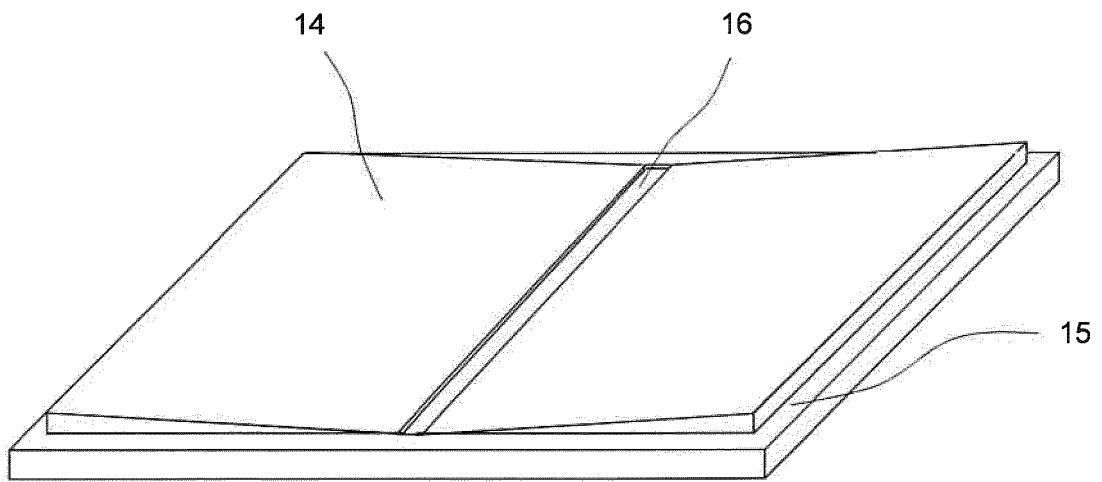

Fig. 3

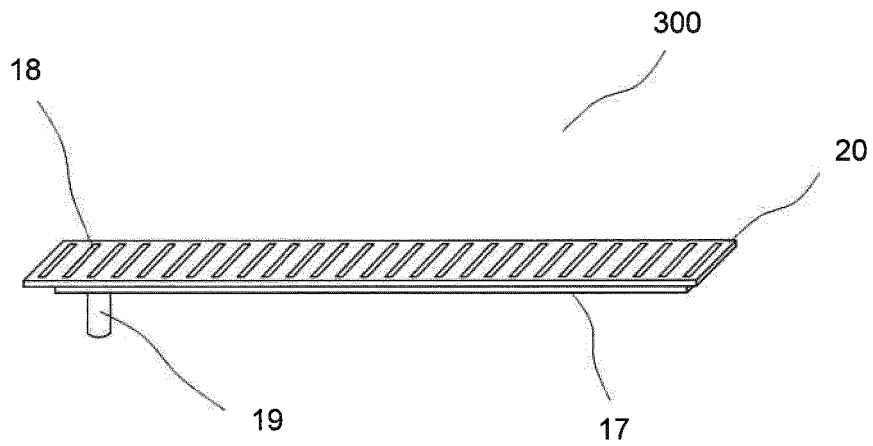

Fig. 4

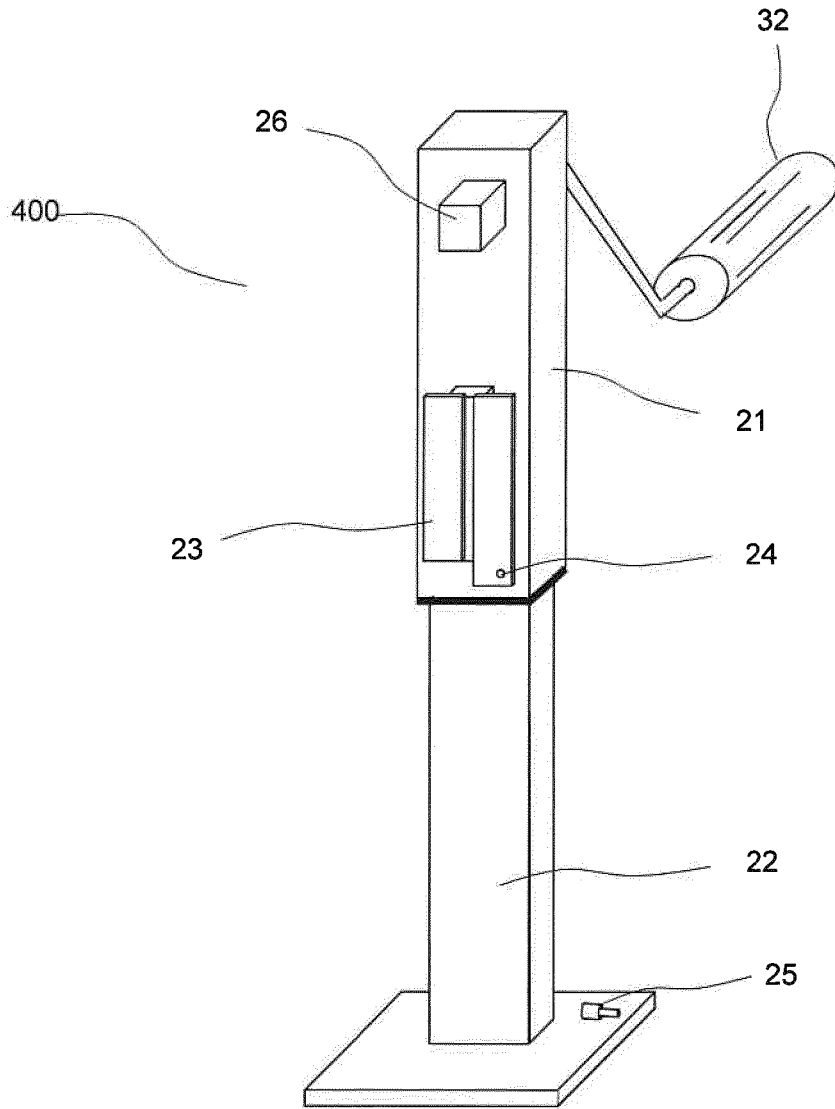

Fig. 5

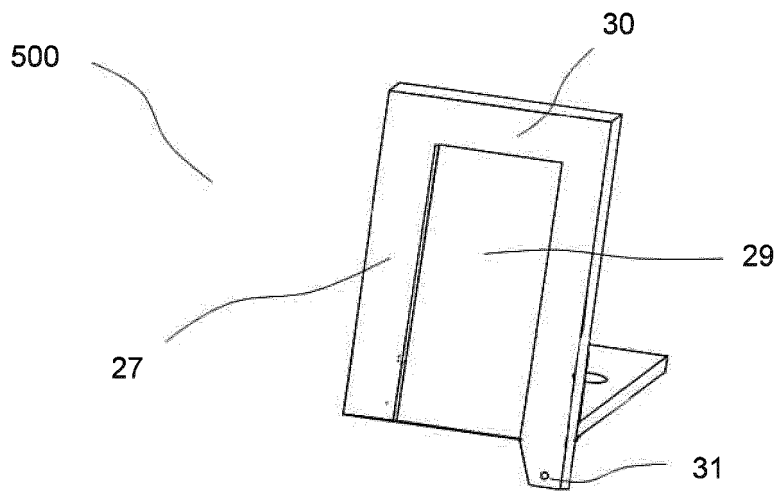

Fig. 6a

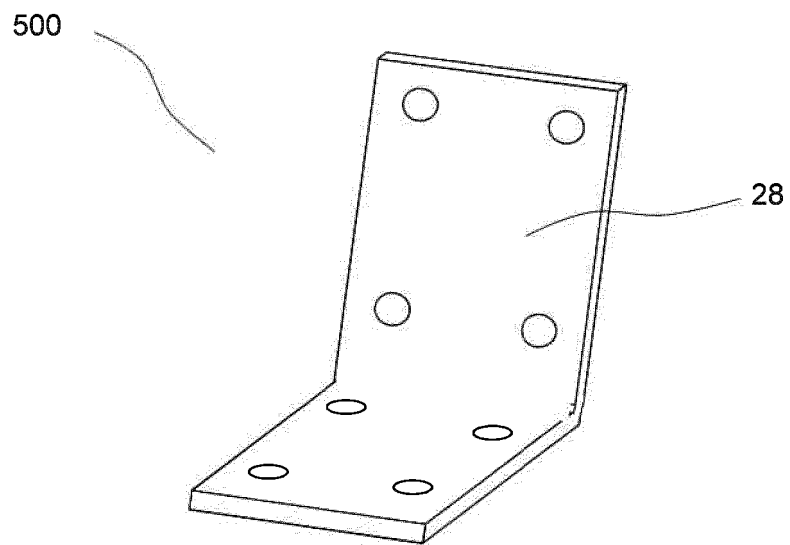

Fig. 6b

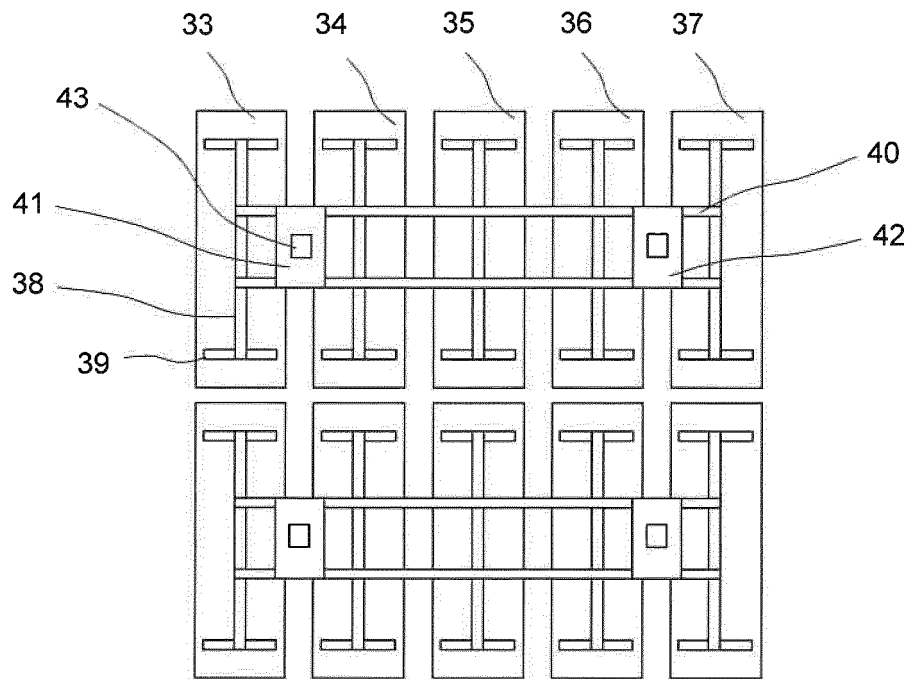

Fig. 7a

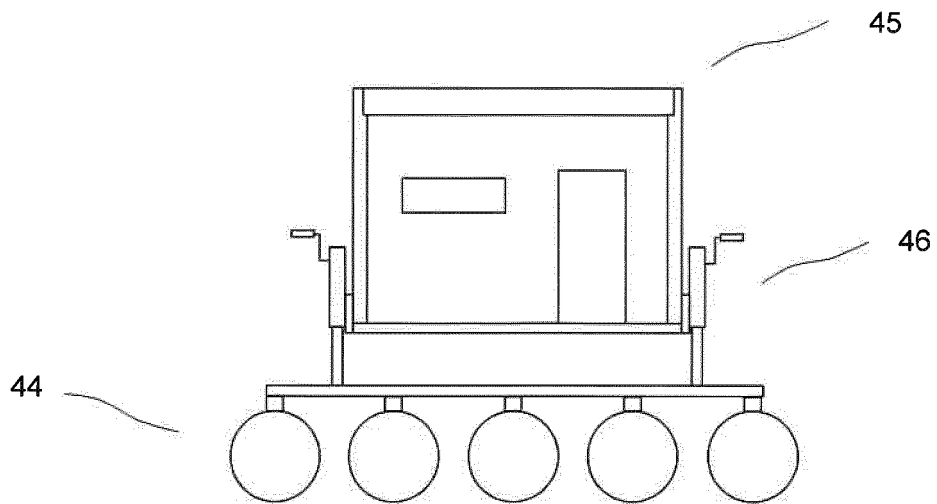

Fig. 7b

REFERENCES CITED IN THE DESCRIPTION

This list of references cited by the applicant is for the reader's convenience only. It does not form part of the European patent document. Even though great care has been taken in compiling the references, errors or omissions cannot be excluded and the EPO disclaims all liability in this regard.

Patent documents cited in the description

- DE 20021424 U1 [0004]
- RU 46417 U1 [0004]
- DE 202013104063 U1 [0004]
- KR 1020100130373 A [0004]
- DE 102013108990 A1 [0004]