

AUSTRALIA

PATENTS ACT 1990

NOTICE OF ENTITLEMENT

We, TRIDON LIMITED of 1150 Corporate Drive, Burlington, Ontario, L7R 4A2, Canada, being the applicant in respect of Application No. 86621/91, state the following:-

1. The person nominated for the grant of the patent has entitlement from the actual inventor by assignment.
2. The person nominated for the grant of the patent has entitlement from the applicant of the application listed in the declaration under Article 8 of the PCT by assignment.
3. The basic application listed in the declaration under Article 8 of the PCT is the first application made in a Convention country in respect of the invention.

For and on behalf of
TRIDON LIMITED

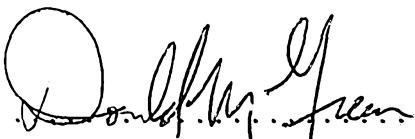
.....
(Signature)

Name: Donald Green.....

Title: Chairman.....

File: 16217.80

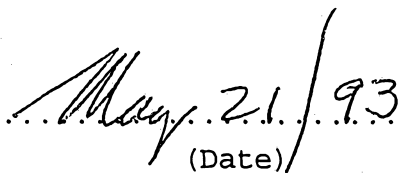
.....
(Date)

SHELSTON WATERS

55 CLARENCE STREET, SYDNEY, AUSTRALIA



AU9186621

(12) PATENT ABRIDGMENT (11) Document No. AU-B-86621/91
(19) AUSTRALIAN PATENT OFFICE (10) Acceptance No. 649274

(54) Title
ADAPTATOR FOR WINDSHIELD WIPER ARMS

International Patent Classification(s)
(51)^s B60S 001/40

(21) Application No. : 86621/91 (22) Application Date : 16.10.91

(87) PCT Publication Number : WO92/06869

(30) Priority Data

(31) Number	(32) Date	(33) Country
600364	19.10.90	US UNITED STATES OF AMERICA

(43) Publication Date : 20.05.92

(44) Publication Date of Accepted Application : 19.05.94

(71) Applicant(s)
TRIDON LIMITED

(72) Inventor(s)
FRANZ BUECHELE

(74) Attorney or Agent
SHELSTON WATERS , 55 Clarence Street, SYDNEY NSW 2000

(56) Prior Art Documents
AU 586348 76345/87 B69S 1/40 F16C 11/04
US 4057869
AU 14306/76 B60S 1/40

(57) Claim

1. An adaptor for coupling a windshield wiper arm to the primary yoke of a windshield wiper superstructure, the primary yoke having a pair of spaced substantially parallel walls on a portion of its length supporting therebetween transversely extending support means to slidably receive the adaptor, the adaptor having first coupling means adapted to receive and retain the free end of a wiper arm and second coupling means adapted to secure the adaptor to the primary yoke, said second coupling means comprising a pair of transversely spaced walls connected by a web extending therebetween, the spacing between the walls of the adaptor being selected to allow the adaptor to be inserted between said parallel walls of the yoke, and the walls of the adaptor each having a first slot extending from an open bottom end to a closed top end whereby the adaptor is adapted to

(11) AU-B-86621/91
(10) 649274

-2-

engage said support means upon downward relative movement of the adaptor into the yoke, the adaptor being characterized in that the first slots each have first and second enlargements longitudinally spaced from each other between said ends, the first enlargement being spaced from the bottom end to retain the adaptor on said support means in a pre-assembled position with the adaptor partially inserted in the yoke such that the resulting yoke and adaptor assembly is disposed to receive a free end of a wiper arm, and the second enlargement being spaced from the top end to retain the adaptor on the support means in a fully assembled position with the adaptor fully inserted in the yoke and the wiper arm secured to the yoke.

INTERNATIONAL APPLICATION PUBLISHED UNDER THE PATENT COOPERATION TREATY (PCT)

<p>(51) International Patent Classification 5 : B60S 1/40</p>	<p>A1</p>	<p>(11) International Publication Number: WO 92/06869 (43) International Publication Date: 30 April 1992 (30.04.92)</p>
<p>(21) International Application Number: PCT/CA91/00367 (22) International Filing Date: 16 October 1991 (16.10.91) (30) Priority data: 600,364 19 October 1990 (19.10.90) US (71) Applicant: TRIDON LIMITED [CA/CA]; 201 North Service Road, Burlington, Ontario L7R 4A2 (CA); P.O. Box 1150 Corporate Drive, Burlington, Ontario L7R 4A2 (72) Inventor: BUCHELE, Franz ; 501 Hood Lake Road, Lawrenceburg, TN 38464 (US). (74) Agents: SCHMIDT, Ingrid, E. et al.; Rogers & Scott, 277 Lakeshore Road East, Suite 201, Oakville, Ontario L6J 6J3 (CA).</p>		<p>(81) Designated States: AT (European patent), AU, BE (European patent), CA, CH (European patent), DE (European patent), DK (European patent), ES (European patent), FR (European patent), GB (European patent), GR (European patent), IT (European patent), JP, LU (European patent), NL (European patent), SE (European patent). Published With international search report. Before the expiration of the time limit for amending the claims and to be republished in the event of the receipt of amendments.</p> <p style="text-align: right; font-size: 2em; font-weight: bold;">649274</p> <p style="text-align: center;">  </p>

see folio 3

(54) Title: ADAPTATOR FOR WINDSHIELD WIPER ARMS

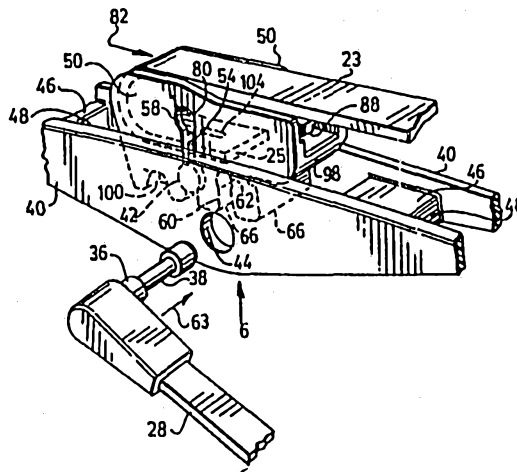

(57) Abstract

An adaptor (24) having first coupling means adapted to receive and retain the free end of a wiper arm which may be of the side pin (28), shepherd's crook (20) or bayonet style (22) and second coupling means adapted to secure the adaptor to the primary yoke (26). The adaptor has transversely spaced walls (50) for insertion between parallel walls (40) of the yoke (26), and the walls (50) of the adaptor each have a downwardly extending slot (54) for engaging support means (42) extending transversely between the walls (40) of the yoke (26). The slots have first (56) and second (58) enlargements longitudinally spaced from each other on the slots, the first enlargement (56) being adapted to retain the adaptor on the support means in a pre-assembled position with the adaptor partially inserted in the yoke and the resulting yoke and adaptor assembly adapted to receive the free end of a wiper arm. The second enlargement (58) is adapted to retain the adaptor (24) on the support means (42) in a fully assembled position with the adaptor fully inserted in the yoke (26) and the wiper arm secured to the yoke.

- 1 -

ADAPTOR FOR WINDSHIELD WIPER ARMS

DESCRIPTION

Technical Field

5 This invention relates to an adaptor used to couple a variety of wiper arm styles to the primary yoke of a windshield wiper superstructure.

Background Art

10 While original equipment manufacturers have the opportunity to select a specific windshield wiper superstructure to cooperate with a preselected wiper arm style, those providing replacement wipers must be able to accommodate a large variety of wiper arm styles and accordingly, adaptors or connectors have
15 been developed for this purpose. Three arm styles known as the bayonet, shepherd's crook and side pin, are very popular but few adaptors have been developed which will accommodate all three styles.

 U.S. Patent No. 4,057,869 shows a connector adapted to
20 cooperate with both the bayonet style arm and the shepherd's crook style arm. The connector body of the structure illustrated in said patent is coupled to the primary yoke of a windshield wiper by means of side panels which straddle the yoke and are secured by a through pin. There exists in the
25 marketplace a modification of this structure wherein the side panels are apertured so as to straddle outwardly extending trunnions provided on the yoke and receive the pin of a side mounted wiper arm. The pin, in this case, is retained in the yoke by a leaf spring assembled within the structure.

30 An object of this invention is to simplify this structure so as to avoid the requirement to provide a leaf spring with which to engage and secure a side pin style of wiper arm and yet be able to continue to accommodate the aforementioned other arm styles.

35 An important advantage which flows from the development of this invention is an easy assembly procedure readily adapted for mass production assembly lines.

 Another object of the invention is to provide a simpler

structure for the adaptor requiring no special retention means to hold the shepherd's crook style of wiper arm in its operative position.

5 Disclosure of Invention

In accordance with this invention, there is provided an adaptor for coupling a windshield wiper arm to the primary yoke of a windshield wiper superstructure, the primary yoke having a pair of spaced substantially parallel walls on a portion of its
10 length supporting therebetween transversely extending support means adapted to slidably receive the adaptor, the adaptor having first coupling means adapted to receive and retain the free end of a wiper arm and second coupling means adapted to secure the adaptor to the primary yoke.

15 The second coupling means comprises a pair of transversely spaced walls connected by a web extending therebetween, the spacing between the walls of the adaptor being selected to allow the adaptor to be inserted between said parallel walls of the yoke, and the walls of the adaptor each
20 having a first slot extending from an open bottom end to a closed top end whereby the adaptor is adapted to engage said support means upon downward relative movement of the adaptor into the yoke.

The first slots each have first and second enlargements longitudinally spaced from each other on said slots, the first
25 enlargement being adapted to retain the adaptor on said support means in a pre-assembled position with the adaptor partially inserted in the yoke and the resulting yoke and adaptor assembly adapted to receive the free end of a wiper arm, and the second enlargement being adapted to retain the adaptor on the support
30 means in a fully assembled position with the adaptor fully inserted in the yoke and the wiper arm secured to the yoke.

Description of Drawings

A preferred embodiment of the invention will now be
35 described with reference to the accompanying drawings, in which:

Fig. 1 is a perspective exploded view showing the adaptor according to the invention before assembly onto the primary yoke of a superstructure forming part of the invention and illustrating a first variant of a shepherd's crook and a

- 3 -

bayonet style of wiper arm for connection to a primary yoke;

Fig. 2 is a perspective view showing the shepherd's crook style arm of Fig. 1 positioned for assembly on the adaptor;

Fig. 3 is a perspective view showing the adaptor of
5 Fig. 1 in a pre-assembled position in the primary yoke with a second variant of the shepherd's crook style arm secured to the adaptor and a side pin style arm disposed for assembly into the primary yoke;

Fig. 4 is a perspective view showing the adaptor
10 carrying the shepherd's crook style arm of Fig. 3 in the fully assembled position inside the primary yoke;

Fig. 5 is a similar view to Fig. 4 with a bayonet style arm attached to the adaptor in its fully assembled position inside the primary yoke;

Fig. 6 is a bottom view taken on line 6 of Fig. 2
15 showing a side pin style arm connected to the adaptor in its fully assembled position; and

Fig. 7 is a similar view to Fig. 6 showing an
20 alternative embodiment of the adaptor connected to a larger diameter pin comprising a side pin style arm connection.

Best Mode for Carrying Out The Invention

Referring firstly to Fig. 1, there is illustrated two
25 styles of wiper arms 20, 22 known as the shepherd's crook and bayonet respectively. An adaptor generally indicated by numeral 24 is provided to couple one of the arms 20, 22 to the primary yoke 26 of a windshield wiper superstructure (not shown). The adaptor 24 will also permit the yoke 26 to be coupled to a side pin style of wiper arm (designated by numeral 28 in Fig. 3).

30 The drawings are illustrative of three popular arm styles: shepherd's crook, bayonet, and side-pin. The shepherd's crook style arm terminates in a U-shaped portion. In a first variant 20 of the shepherd's crook, the legs 30, 31 remote from an arm socket 21 are substantially parallel and
35 separated by a predetermined distance indicated by arrow 32 and nominally assigned the value x. It will be understood that the relative length of the operatively lower leg 31 may vary.

For example, in a second variant 23 of the arm shown in

- 4 -

Fig. 3, the operatively lower leg 25 is longer. The first variant 20 also differs from the second variant 23 in that the legs 30, 31 are connected to a main portion of the arm in line with the arm socket 21 by a transverse portion 27 which meets the upper leg 30 at an obtuse angle so as to space the arm from a windshield.

The bayonet style arm 22 comprises a plate of narrow width having an upwardly projecting nib 34 positioned adjacent the end of the arm 22.

10 The side pin style arm 28 includes a pin 36 which is orthogonal to the arm and has a circumferential groove 38 between its ends.

The primary yoke 26 shown in the drawings has a pair of spaced substantially parallel walls 40 on a portion of its length, usually between ends of the yoke which terminate in spaced flanges adapted for pivotally connecting the yoke to respective secondary yokes (not shown). A support means for the adaptor 24 in the form of axially aligned oppositely directed stubs 42 extend transversely between the walls 40. A pair of oppositely located apertures 44 downwardly and longitudinally spaced from the stubs 42 are formed in the walls 40 and are dimensioned to receive therethrough the pin 36. A pair of transversely extending generally horizontal webs 46 connect the walls 40 and are spaced longitudinally from each other to either side of the stubs 42 so as to accommodate the adaptor 24 therebetween. Downwardly extending webs 48 contiguous with the webs 46 are provided for added strength in this central area of the primary yoke 26.

30 It will be understood that the adaptor 24 in use locates between the walls 40 of the primary yoke 26 and has first coupling means adapted to receive and retain the free end of a wiper arm and second coupling means to secure the adaptor to the primary yoke.

35 Like the yoke 26, the adaptor 24 is molded from synthetic plastic material and comprises a pair of transversely spaced walls 50, the spacing between the walls 50 of the adaptor being selected to allow the adaptor to be inserted between the walls 40 of the yoke. In the embodiment illustrated, the walls

- 5 -

50 are connected by several webs extending between the walls some of which have other functions which will be described later. One such web 52 is positioned adjacent the operative bottom of the adaptor 24 (as drawn).

5 A first downwardly extending slot 54 is provided in each of the walls 50 to define coupling means for securing the adaptor to the primary yoke 26. The slots 54 are closed at the top and are open at the bottom of the adaptor 24 to allow the adaptor to engage the stubs 42 upon downward relative movement
10 of the adaptor into the yoke 26. Each slot 54 also has a first enlargement 56 and a second enlargement 58 longitudinally spaced from each other on the slots, the first enlargement 56 being spaced a short distance from the bottom of the adaptor 24 and the second enlargement 56 being formed at the operatively upper
15 end of the slot, corresponding to pre-assembled and fully assembled positions of the adaptor in the yoke.

Coupling means for connection to the side pin style arm 28 are defined by second downwardly extending slots 60 provided in each side 50 and parallel to the first slots 54. The slots
20 60 are open at the bottom of the adaptor and terminate in a third enlargement 62 formed in the walls 50. The slots 60 are longitudinally spaced from the first slots 54 by a distance equalling the longitudinal separation between the stubs 42 and the apertures 44 formed in the walls 40 of the primary yoke 26.
25 The third enlargements 62 are spaced from the bottom of the adaptor 24 so that the separation between the enlargements 62 and the apertures 44 in the pre-assembled position of the adaptor will correspond to the separation between the first and second enlargements 56, 58 provided on the first slots 54.

30 The assembly of the adaptor 24 in the yoke 26 to couple the wiper to the side pin arm 28 will now be described.

To begin, the adaptor 24 is positioned in the pre-assembled position in which the adaptor is partially inserted in the yoke 26 by moving the adaptor downwardly as
35 indicated by arrow 61 relative to the yoke until the stubs 42 locate in the first enlargement 56 of the slots 54 (Fig. 2). In this pre-assembled position of the adaptor, the bottom of the adaptor 24 clears the apertures 44 and thereby allows the side

- 6 -

pin 36 to be inserted in the yoke as indicated by arrow 63 with the ends of the pin supported on the walls 40.

The adaptor 24 is then brought to a fully assembled position by pushing downwardly as indicated by arrow 86 (Fig. 4) on the adaptor until the stubs 42 locate in the second enlargement 58 and the ends of the pin 36 locate in the third enlargements 62. Oppositely directed shoulders 64 (Fig. 6) provided on spaced parallel sides 66 extending transversely between the walls 50 of the adaptor and terminating adjacent the second slots 60 locate in the circumferential groove 38 of the pin and thereby restrain any relative transverse movement between the pin 36 and the yoke 26. It will be understood that the sides 66 must flex away from each other upon said downward movement of the adaptor 24 over the pin 36. In order to facilitate the flexing of the sides 66, an undercut 68 is formed in the wall 50 adjacent the second slot 60.

In Fig. 7, there is shown an alternative embodiment of the adaptor 69 in which the spacing and size of shoulders 70 corresponding to the shoulders 64 of the first embodiment illustrated in Figs. 1 - 5 are provided to locate in a side pin arm 72 of which the side pin 74 has a larger diameter and accordingly has a groove 76 which locates between the sides 50 of the adaptor whereas in the first embodiment shown in Fig. 6 the groove 38 locates adjacent one side 50 of the adaptor. As all other components are the same in the second embodiment, they are numbered with like numerals in Fig. 7.

The remaining portions of the adaptor 24 provided for coupling the primary yoke 26 to a shepherd's crook style of wiper arm will now be described with reference being made once more to Fig. 1.

Substantially parallel upper and lower abutment surfaces 78, 80 upwardly spaced from the first enlargement 56 extend orthogonally between the walls 50 of the adaptor at one end thereof diagonally opposite the second slot 60. The abutment surfaces 78, 80 curve towards each other at a forward end of the adaptor drawn to the left of the drawing (Fig. 1) and are joined to define a smoothly contoured surface which will nest in the crook of the arm 20 when the arm 20 is moved

- 7 -

longitudinally between the walls 50 of the adaptor as indicated by arrow 82 in Fig. 3 and arrow 83 in Fig. 2.

It will be noted from Fig. 2 that the transverse portion 27 of the arm 20 is accommodated in the adaptor 24 by forming one of the walls 50 with a reduced height at the back of the adaptor (drawn to the right) and adjacent a tab 88 cantilevered from the upper abutment surface 78 and described in more detail below with reference to the bayonet style of arm 22. The wall portion of reduced height is generally indicated by reference numeral 51.

The abutment surfaces 78, 80 are adapted to be received between the legs 30, 31 of the arm. A pair of shoulders 84 extending longitudinally on opposite sides on the upper abutment surface 78 adjacent the associated walls 50 of the adaptor is provided to increase the effective separation between the upper and lower abutment surfaces so that it corresponds to the distance x indicated by arrow 32, being the separation between the legs 30, 31. Thus, by nesting firmly between the legs 30, 31 there is no upward relative movement between the abutment surfaces 78, 80 of the adaptor 24 and the arm 20. Similarly, the separation between the walls 50 of the adaptor which extend upwardly a short distance above the upper abutment surface 78 is selected to correspond to the width of the legs 30 to constrain lateral relative movement between the arm 20 and the adaptor 24.

It will be understood that the separation between the lower abutment surface 80 and the first enlargement 56 is sufficient to accommodate the lower leg 25, 31 and to permit installation of the arm 23, 20 on the adaptor 24 in the pre-assembled position illustrated in Fig. 3. The lower abutment surface 80 and the web 52 also define a passage which receives the lower leg 25, 31.

Having reference particularly to the second variant 23 of the shepherd's crook style arm, the thickness of the stubs 42 is selected to at most equal the thickness of the walls 50 so that the separation between the stubs 42 is sufficient to accommodate the width of the lower leg 25 without any interference therebetween when the adaptor 24 is pushed downwardly into the yoke 26 as indicated by arrow 86 in Fig. 4

- 8 -

into the fully assembled position.

A third component of the first coupling means adapted to couple the byonet style arm 22 to the yoke 26 comprises a tab 88 cantilevered from the upper abutment 78 at the back end of the adaptor 24 (drawn to the right in Fig. 1). The tab 88 has an aperture 90 whereby the tab is adapted to snap into engagement with the nib 34 upon forward relative movement of the arm 22 toward the adaptor as indicated by arrow 92. The operatively lower surface of the tab 88 has a ramp 94 for guiding the nib 34 towards engagement in the aperture 90. To constrain relative lateral movement between the arm 22 and the adaptor 24, a socket 96 is formed in the adaptor 24 which is defined at the upper end by the tab 88, at the sides by the walls 50, and at the bottom by a transversely extending web portion 98 orthogonal to the walls 50 and adjacent the undercut 68.

The assembly is completed by first positioning the adaptor 24 in the pre-assembled position of Fig. 3 where it is ready to receive the arm 22 and thereafter pushing downwardly on the adaptor so that it can assume the fully assembled position as illustrated in Fig. 5.

Finally, the adaptor 24 is provided with a pair of notches 100 extending downwardly from the web 52 and through the walls 50 of the adaptor. The notches 100 open at the bottom of the adaptor are separated by a longitudinally extending web 102. These notches 100 are adapted to engage on a conveyor carrying the adaptors in mass production assembly operations and may be provided on an optional basis for sorting operations to separate adaptors 24 dimensioned to accommodate small diameter pins from adaptors 69 dimensioned to accommodate large diameter pins.

Industrial Applicability

It will also be appreciated that the pre-assembled (Fig. 2) and fully assembled (Fig. 3) positions of the adaptor are very advantageous to the original equipment manufacturer assembling arms to wiper superstructures on a mass production basis, since the adaptors can all be pre-assembled on the yokes

- 9 -

before attachment to the wiper arms which will normally have already been installed on the motor vehicle for which the wiper is destined. Moreover, the attachment of the wiper arm to the adaptor and yoke assembly is very simple and requires no complex
5 manipulation of clips or springs to engage in the groove 38 in the case of a side pin style arm 28 or complex manoeuvring of the wiper arm into the yoke in the case of a shepherd's crook style arm 20. Once the arm is positioned into the adaptor and yoke assembly, only a simple downward push on the adaptor is
10 required to bring it to the fully assembled position.

The adaptor according to the invention does not require any separate tab portion or projection for engaging an aperture 104 (see Fig. 3) normally provided in shepherd's crook style arms in order to secure this style arm into the assembly for
15 this purpose. With the adaptor according to the invention, no such aperture 104 is required and therefore the expense associated with punching the aperture and also the problems associated with centering and positioning the aperture relative to the operatively lower leg 31 are avoided. Without the need
20 to provide such an aperture, the length of the operatively lower leg 31 on a shepherd's crook style arm 20 may also be shorter such that it will not traverse the slot 54 of the the adaptor when it is assembled with same. In such a case, the associated primary yoke 26 could have transversely extending support means
25 in the form of a pin or rod replacing the stubs 42.

It will also be appreciated that the side pin style arm 28 is firmly locked in position by the adaptor 24 in the yoke 26 and will not rotate relative to the yoke because the adaptor is fixed to the yoke in two spaced locations, namely at the stubs
30 42 and at the pin 36.

The invention thus provides an adaptor which is a simple expedient for connecting a windshield wiper yoke to a variety of styles of wiper arms and also simplifies mass assembly operations.

35 As indicated above, several variations may be made to the above described embodiments of the invention without departing from the scope of the appended claims.

INDEX OF REFERENCE SIGNS

	20	wiper arm (shepherd's crook 1st variant)
	21	arm socket
5	22	arm socket (bayonet)
	23	wiper arm (shepherd's crook 2nd variant)
	24	adaptor
	25	lower leg
	26	primary yoke
10	27	transverse portion
	28	wiper arm (side pin)
	30	upper leg
	31	lower leg
	32	arrow
15	34	nib
	36	side pin
	38	groove
	40	walls
	42	stubs
20	44	apertures
	46	horizontal webs
	48	downward webs
	50	walls
	51	wall (reduced height)
25	52	web
	54	1st slots
	56	1st enlargement
	58	2nd enlargement
	60	2nd slots
30	61	arrow
	62	3rd enlargement
	63	arrow
	64	shoulders
	66	sides
35	68	undercut
	69	adaptor
	70	shoulders
	72	side pin arm

INDEX OF REFERENCE SIGNS

	74	side pin
	76	groove
5	78	upper abutment surface
	80	lower abutment surface
	82	arrow
	83	arrow
	84	shoulders
10	86	arrow
	88	tab
	90	aperture
	92	arrow
	94	ramp
15	96	socket
	100	notches
	102	web
	104	aperture

THE CLAIMS DEFINING THE INVENTION AS FOLLOWS:-

1. An adaptor for coupling a windshield wiper arm to the primary yoke of a windshield wiper superstructure, the
5 primary yoke having a pair of spaced substantially parallel walls on a portion of its length supporting therebetween transversely extending support means to slidably receive the adaptor, the adaptor having first coupling means adapted to receive and retain the free end of a wiper arm and second
10 coupling means adapted to secure the adaptor to the primary yoke, said second coupling means comprising a pair of transversely spaced walls connected by a web extending therebetween, the spacing between the walls of the adaptor being selected to allow the adaptor to be inserted between
15 said parallel walls of the yoke, and the walls of the adaptor each having a first slot extending from an open bottom end to a closed top end whereby the adaptor is adapted to engage said support means upon downward relative movement of the adaptor into the yoke, the adaptor being characterized
20 in that the first slots each have first and second enlargements longitudinally spaced from each other between said ends, the first enlargement being spaced from the bottom end to retain the adaptor on said support means in a pre-assembled position with the adaptor partially inserted
25 in the yoke such that the resulting yoke and adaptor assembly is disposed to receive a free end of a wiper arm, and the second enlargement being spaced from the top end to retain the adaptor on the support means in a fully assembled

position with the adaptor fully inserted in the yoke and the wiper arm secured to the yoke.

2. Adaptor according to claim 1 in which the yoke further
5 includes a pair of oppositely located apertures downwardly spaced from said support means and dimensioned to receive therethrough a pin of a side pin style of wiper arm having a circumferential groove between its ends, said first coupling means being adapted to receive the free end of a side pin
10 style of wiper arm and comprising a pair of oppositely directed shoulders provided on spaced parallel sides extending transversely between the walls of the adaptor, the shoulders locating in said circumferential groove in the fully assembled position of the adaptor upon downward
15 relative movement of the adaptor over the pin.

3. Adaptor according to claim 2 in which said apertures are longitudinally spaced from said support means and the sides traversing the adaptor terminate adjacent a second
20 downwardly extending slot provided in each of the walls of the adaptor, the second slots being parallel to the first slots and terminating in a third enlargement adapted to retain the pin and spaced from the bottom of the adaptor so that the separation of the third enlargement from the
25 apertures in the pre-assembled position of the adaptor corresponds to the separation between the first and second enlargements provided on the first slots.

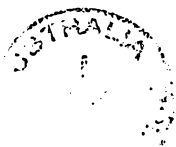

4. Adaptor according to claim 1 in which said first coupling means includes means to receive a free end of a shepherd's crook style of wiper arm having a U-shaped end defined by an operatively upper and lower leg which are

5 substantially parallel and separated by a predetermined distance x , said means comprising substantially parallel upper and lower abutment surfaces upwardly spaced from the first enlargement on the first slots and extending between

10 the walls of the adaptor, the abutments being received between the legs of the arm upon relative longitudinal movement of the arm and the adaptor such that the lower leg lies above the first enlargement of the slots thereby permitting the arm to be installed on the adaptor in the pre-assembled position of the adaptor, the effective

15 separation between said abutment surfaces being selected to correspond to said separation x between the legs to constrain upward relative movement between the arm and the adaptor, and the effective separation between the walls of the adaptor being selected to correspond to the width of the

20 legs to constrain lateral relative movement between the arm and the adaptor, continued relative movement between the arm and the adaptor being arrested by the abutments meeting against the U-shaped end of the arm.

25 5. Adaptor according to claim 4 in which the support means on the primary yoke comprises a pair of oppositely directed stubs separated by a distance which is at least equal to the width of the legs so that a shepherd's crook style of wiper

arm of which the operatively lower leg is long enough to traverse the first slots will not interfere with the support means upon downward relative movement of the adaptor in the yoke.

5

6. Adaptor according to claim 2 in which said first coupling means includes means to receive a free end of a shepherd's crook style of wiper arm having a U-shaped end defined by an operatively upper and lower leg which are substantially parallel and separated by a predetermined distance x , said means comprising substantially parallel upper and lower abutment surfaces upwardly spaced from the first enlargement on the first slots and extending between the walls of the adaptor, the abutments being received between the legs of the arm upon relative longitudinal movement of the arm and the adaptor such that the lower leg lies above the first enlargement of the slots thereby permitting the arm to be installed on the adaptor in the pre-assembled position of the adaptor, the effective separation between said abutment surfaces being selected to correspond to said separation x between the legs to constrain upward relative movement between the arm and the adaptor, and the effective separation between the walls of the adaptor being selected to correspond to the width of the legs to constrain lateral relative movement between the arm and the adaptor, continued relative movement between the arm and the adaptor being arrested by the abutments meeting against the U-shaped end of the arm.

10

15

20

25

7. Adaptor according to claim 3 in which said first
coupling means is adapted to receive the free end of a
shepherd's crook style of wiper arm having a U-shaped end
5 defined by an operatively upper and lower leg which are
substantially parallel and separated by a predetermined
distance x , said first coupling means comprising
substantially parallel upper and lower abutment surfaces
upwardly spaced from the first enlargement on the first
10 slots and extending between the walls of the adaptor, the
abutments being adapted to arrest longitudinal movement of
the arm between the walls of the adaptor with said abutment
surfaces aligned to be received between the legs of the arm
upon relative longitudinal movement of the arm and the
15 adaptor such that the lower leg lies above the first
enlargement of the slots thereby permitting the arm to be
installed on the adaptor in the pre-assembled position of
the adaptor, the effective separation between said abutment
surfaces being selected to correspond to said separation x
20 between the legs to constrain upward relative movement
between the arm and the adaptor, and the effective
separation between the walls of the adaptor being selected
to correspond to the width of the legs to constrain lateral
relative movement between the arm and the adaptor, continued
25 relative movement between the arm and the adaptor being
arrested by the abutments meeting against the U-shaped end
of the arm.

8. Adaptor according to claim 7 in which the support means on the primary yoke comprises a pair of oppositely directed stubs separated by a distance which is at least equal to the width of the legs so that a shepherd's crook style of wiper arm of which the operatively lower leg is long enough to traverse the first slots will not interfere with the support means upon downward relative movement of the adaptor in the yoke.

10 9. Adaptor according to claim 8 in which said first coupling means is also adapted to receive the free end of a bayonet style of wiper arm having an upwardly projecting nib, the first coupling means comprising a tab cantilevered from the upper abutment surface between the walls of the adaptor and having an aperture whereby the tab is adapted to snap into engagement with the nib.

20 10. Adaptor according to claim 4 in which said first coupling means is also adapted to receive the free end of a bayonet style of wiper arm having an upwardly projecting nib, the first coupling means comprising a tab cantilevered from the upper abutment surface between the walls of the adaptor and having an aperture whereby the tab is adapted to snap into engagement with the nib.

DATED this 10th day of September, 1993
TRIDON LIMITED

Attorney: LEON K. ALLEN
Fellow Institute of Patent Attorneys of Australia
of SHELSTON WATERS

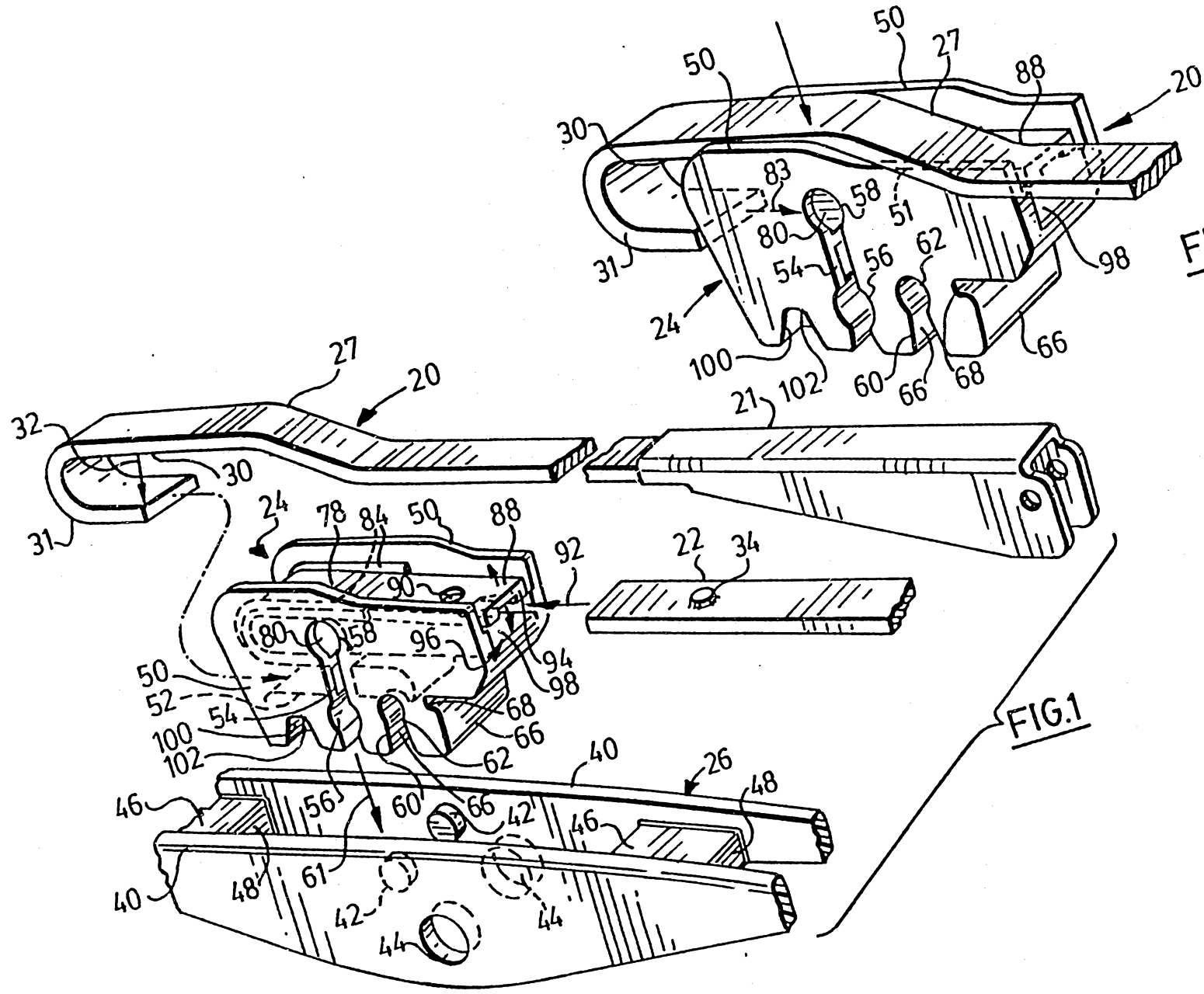

FIG. 2

FIG. 1

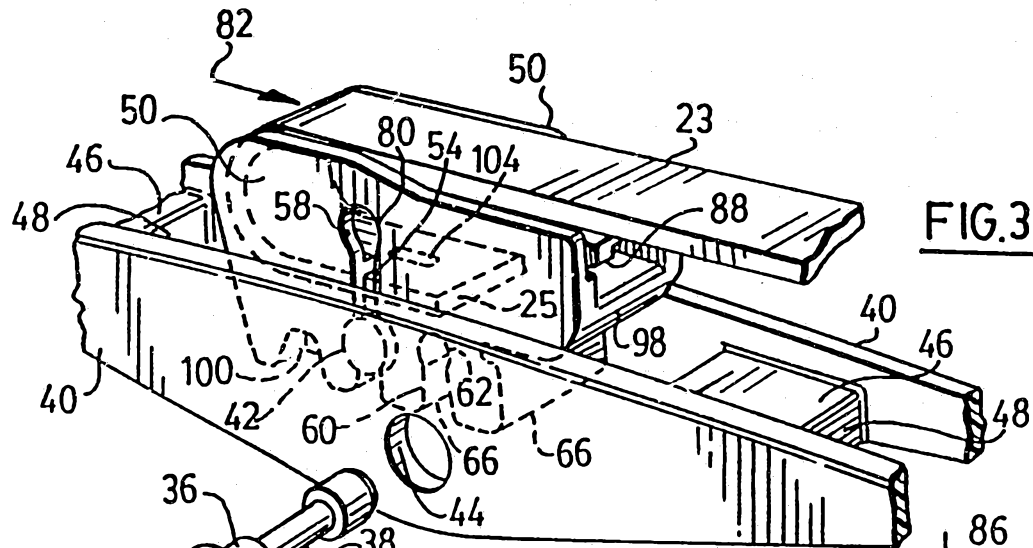

FIG. 3

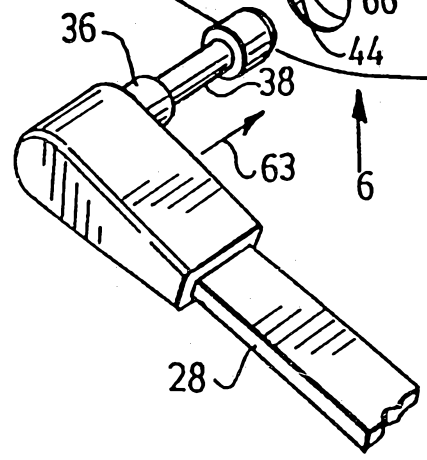

FIG. 4

3/3

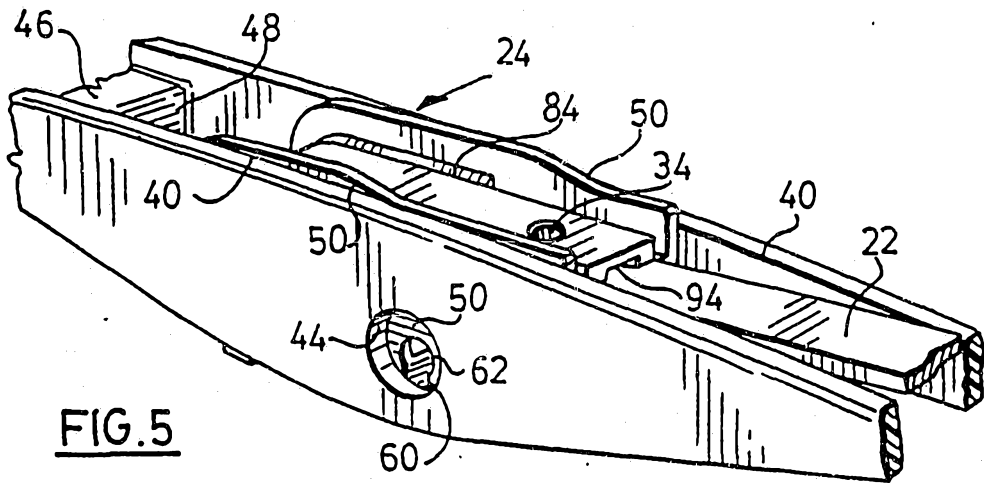

FIG. 5

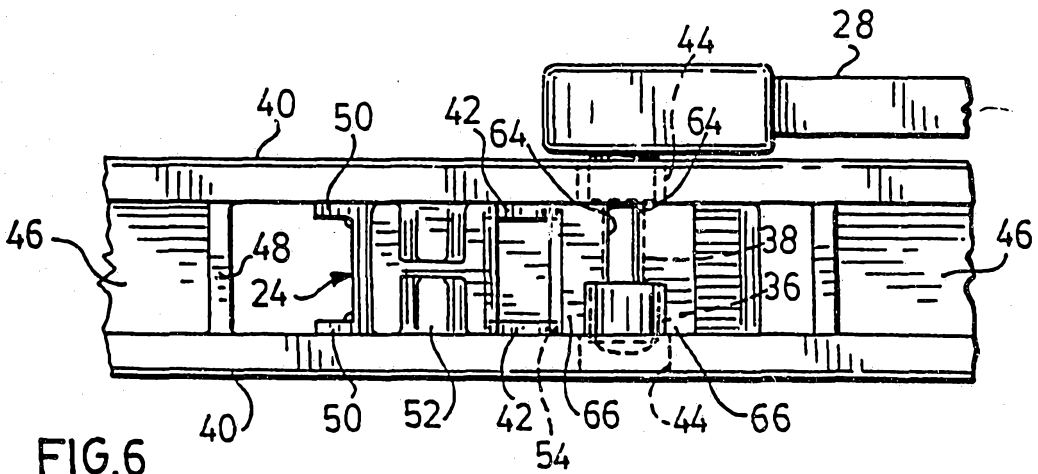

FIG. 6

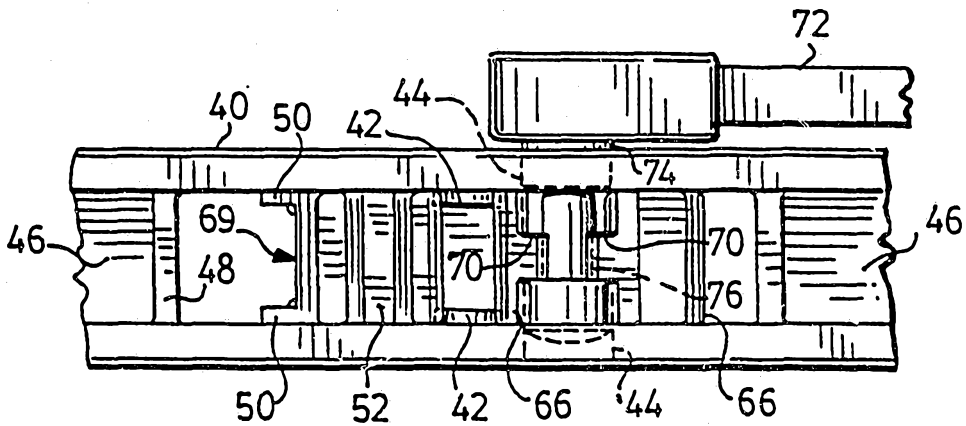

FIG. 7

INTERNATIONAL SEARCH REPORT

PCT/CA 91/00367

International Application No

I. CLASSIFICATION OF SUBJECT MATTER (If several classification symbols apply, indicate all) ⁵		
According to International Patent Classification (IPC) or to both National Classification and IPC Int.Cl. 5 B60S1/40		
II. FIELDS SEARCHED		
Minimum Documentation Searched ⁷		
Classification System	Classification Symbols	
Int.Cl. 5	B60S	
Documentation Searched other than Minimum Documentation to the Extent that such Documents are Included in the Fields Searched ⁸		
III. DOCUMENTS CONSIDERED TO BE RELEVANT⁹		
Category ¹⁰	Citation of Document, ¹¹ with Indication, where appropriate, of the relevant passages ¹²	Relevant to Claim No. ¹³
A	US,A,4 057 869 (LONGMAN ET AL.) 15 November 1977 cited in the application see column 2, line 19 - column 4, line 64; figures ---	1,4,6,7, 9-11,14, 16,17,19
A	FR,A,2 524 409 (TRICO-FOLBERTH LTD.) 7 October 1983 see page 6, line 8 - page 10, line 14; figures 1,2,4-8 ---	1,4,6,7, 9-11,14, 16,17,19
A	DE,U,8 518 656 (FISTER S.P.A) 5 September 1985 see page 8, line 6 - page 11, line 13; figures --- -/--	1-3, 9-13,19
<p>¹⁰ Special categories of cited documents:</p> <p>"A" document defining the general state of the art which is not considered to be of particular relevance</p> <p>"E" earlier document but published on or after the international filing date</p> <p>"L" document which may throw doubts on priority claim(s) or which is cited to establish the publication date of another citation or other special reason (as specified)</p> <p>"O" document referring to an oral disclosure, use, exhibition or other means</p> <p>"P" document published prior to the international filing date but later than the priority date claimed</p> <p>"T" later document published after the international filing date or priority date and not in conflict with the application but cited to understand the principle or theory underlying the invention</p> <p>"X" document of particular relevance; the claimed invention cannot be considered novel or cannot be considered to involve an inventive step</p> <p>"Y" document of particular relevance; the claimed invention cannot be considered to involve an inventive step when the document is combined with one or more other such documents, such combination being obvious to a person skilled in the art.</p> <p>"&" document member of the same patent family</p>		
IV. CERTIFICATION		
Date of the Actual Completion of the International Search	Date of Mailing of this International Search Report	
30 JANUARY 1992	17 9. 02. 92	
International Searching Authority	Signature of Authorized Officer	
EUROPEAN PATENT OFFICE	KULOZIK E.G. <i>E. Kulozik</i>	

Category °	Citation of Document, with indication, where appropriate, of the relevant passages	Relevant to Claim No.
A	DE,A,1 905 352 (SOCIETE ANONYME POUR L'EQUIPMENTS ELECTRIQUE DES VEHICULES S.E.V.) 25 September 1969 see page 12, line 11 - page 13, line 19; figure 5 ---	1,5,8, 15,18
A	EP,A,0 285 262 (NIPPON WIPER BLADE CO., LTD) 5 October 1988 ---	

ANNEX TO THE INTERNATIONAL SEARCH REPORT
ON INTERNATIONAL PATENT APPLICATION NO. CA 9100367
SA 52137

This annex lists the patent family members relating to the patent documents cited in the above-mentioned international search report. The members are as contained in the European Patent Office EDP file on The European Patent Office is in no way liable for these particulars which are merely given for the purpose of information. 30/01/92

Patent document cited in search report	Publication date	Patent family member(s)	Publication date
US-A-4057869	15-11-77	None	
FR-A-2524409	07-10-83	AU-B- 561017	30-04-87
		BE-A- 896356	01-08-83
		DE-A,C 3311303	20-10-83
		GB-A,B 2119637	23-11-83
		JP-B- 1048183	18-10-89
		JP-C- 1565967	25-06-90
		JP-A- 58199252	19-11-83
DE-U-8518656	05-09-85	FR-A,B 2568529	07-02-86
		GB-A,B 2163042	19-02-86
DE-A-1905352	25-09-69	GB-A- 1212337	11-11-70
		US-A- 3576044	27-04-71
EP-A-0285262	05-10-88	JP-A- 63215451	07-09-88
		US-A- 4866812	19-09-89