

Aug. 10, 1965

T. F. MARCHIONDA

3,199,706

BOTTLE CAP WITH SELF-OPENING TAB

Filed June 18, 1964

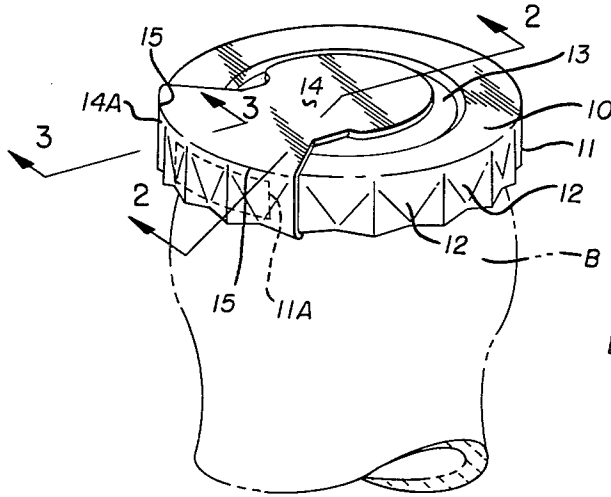

FIG. 1

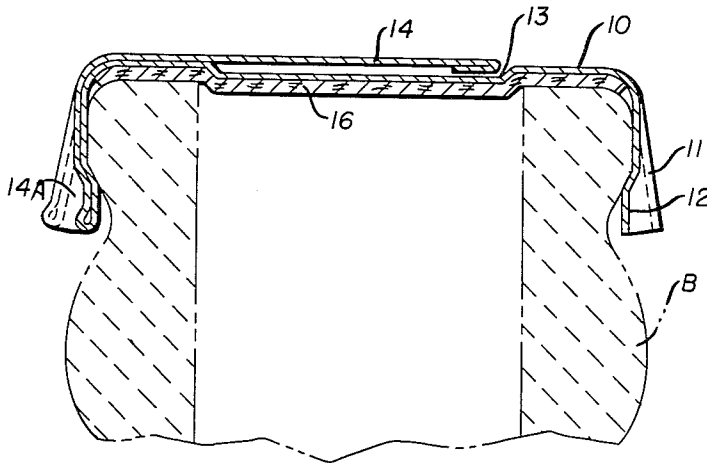

FIG. 2

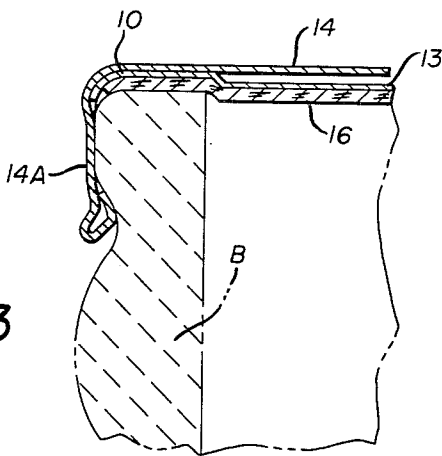

FIG. 3

INVENTOR
TONY F. MARCHIONDA
BY *W. B. Harpman*
ATTORNEY

1

2

3,199,706

BOTTLE CAP WITH SELF-OPENING TAB

Tony F. Marchionda, 708 5th St., Struthers, Ohio

Filed June 18, 1964, Ser. No. 376,177

1 Claim. (Cl. 215-46)

This invention relates to a bottle cap, such as used on carbonated beverages, beer and the like and more particularly to a bottle cap incorporating a self-opening tab which may be grasped by the user and used to conveniently and easily open the clinched bottle cap.

The principal object of the invention is the provision of a bottle cap with a self-opening tab arranged to release a portion of the clinched skirt of the bottle cap.

A further object of the invention is the provision of a bottle cap with a self-opening tab arranged to position a major portion of the tab in a recessed area in the top of the bottle cap.

A still further object of the invention is the provision of a bottle cap with a self-opening tab having means for weakening the normally crimped bottle engaging portion of the skirt of the cap so that the self-opening tab may easily open the same.

The self-opening bottle cap disclosed herein comprises an improvement in the art of bottle caps or crowns, as they are sometimes known in the art, in that a device is disclosed which may be inexpensively formed of a single section of inexpensive material, such as enameled sheet steel, and applied to bottles such as used for packaging carbonated beverages, beer and the like by conventional capping equipment. It is recognized that many attempts had been made to form self-opening bottle caps and generally these have been impractical, either by reason of their complicated manufacture or high cost, or their actual inability to function efficiently for their intended purpose.

The present invention is believed to overcome the several deficiencies heretofore existing in the proposed self-opening bottle caps and to provide a structure which meets the several objects of the invention.

With the foregoing and other objects in view which will appear as the description proceeds, the invention resides in the combination and arrangement of parts and in the details of construction hereinafter described and claimed, it being the intention to cover all changes and modifications of the example of the invention herein chosen for purposes of the disclosure, which do not constitute departures from the spirit and scope of the invention.

The invention is illustrated in the accompanying drawing, wherein:

FIGURE 1 is a perspective view of a self-opening bottle cap in position on a broken line illustration of a bottle top.

FIGURE 2 is an enlarged cross sectional view on line 2-2 of FIGURE 1.

FIGURE 3 is an enlarged cross sectional view on line 3-3 of FIGURE 1.

By referring to the drawings and FIGURE 1 in particular, it will be seen that a bottle cap is shown in position on top of a bottle B and comprises an annular disc 10 having an annular depending flange 11 which is crimped at circumferentially spaced locations thereabout as customary in the bottle cap art so that the indented por-

tions 12, 12 lie beneath the rim of the bottle B, which rim surrounds the opening of the bottle as will be understood by those skilled in the art. Additionally, the disc 10 is provided with a central depressed circular area 13 and a self-opening tab 14 is normally positioned partially within the depressed area 13 and extends sidewardly to one side of the bottle cap disc 10 and then downwardly in an extension 14, which is bent at right angles on bend line 15. The extension 14 is integral with and extends into the lower edge of the annular crimped flange 11, and it will be observed that a cutaway area 11A wider than its height is formed in the area of the crimped annular flange 11 underlying the extension 14. The height of the cutaway area or opening 11A is slightly less than the height of the flange 11 and of a width approximately three times its height. The indented portions 12, 12 of the annular depending flange 11 are therefore not present in the cutaway area 11A thereof but are formed instead in the extension 14A of the self-opening tab 14. The bottle cap thus disclosed is conveniently and easily formed from a sheet of metal, such as steel, with the disc 10 and annular flange portion 11 being circular with the tab portion 14 and its downward extension 14A extending as a sideward projection from such a disc in the blank form of the bottle cap.

It will further be observed that the cutaway area or opening 11A in the annular flange 11 of the disc 10 is such that the remaining portion of the flange 11 as seen in FIGURES 1 and 3 is relatively shorter than the remaining portion of the annular flange 11.

It will further be seen that when the self-opening tab 14 is lifted up from its flat nested position, as seen in FIGURE 1 of the drawings, and moved upwardly and outwardly, it disengages the indented portions 12, 12 thereof from the bottle B and permits the cap to be lifted upwardly and pulled away from its closed position on the bottle B.

By referring now to FIGURE 2 of the drawings, the cap in normally closed position on the bottle may be seen, and it will be observed that the extension 14 is crimped by the bottle capping machinery to form the indentations 12 which engage beneath the annular rim of bottle B. In FIGURE 2 of the drawings, the sealing insert, which is usually cork, is illustrated and identified by the reference numeral 16.

By referring now to FIGURE 3 of the drawings, it will be seen that the cross section on line 3-3 of FIGURE 1 illustrates the relatively short portion of the annular flange 11 above the cutaway area 11A therein and its lessened engagement on the neck of the bottle B, and it will be readily understood that it will not require much effort applied to the self-pull tab 14 to free the extension so that the bottle cap may be removed. It will also be observed that there is sufficient material in the extension 14 and sufficient indentations 12, 12 formed therein by the capping machine to secure the cap tightly to the bottle and prevent pressure build-up in the bottle from blowing the cap off when the extension 14 is in normal close relation thereto.

It will thus be seen that a self-opening bottle cap has been disclosed which may be inexpensively formed of sheet steel by relatively simple tools and applied with existing capping machinery to bottles, such as used for carbonated beverages, beer and the like, and that the invention disclosed meets the several objects hereinbefore set

forth, and having thus described my invention, what I claim is:

A self-opening bottle cap comprising an annular disc having an annular depending flange thereabout arranged to be crimped upon a neck of a bottle so as to be secured thereto thereby, said depending flange having an opening therein of a height slightly less than the height of said flange and a width approximately three times its height, said annular flange having an integral extension adjacent said opening forming a pull tab said extension being wider than said opening, said extension normally folded back over said opening in said flange and extending over said annular disc and lying adjacent thereto, said exten-

sion arranged to be crimped in the manner of the annular flange of said cap so as to substantially engage said bottle through said aperture.

References Cited by the Examiner

FOREIGN PATENTS

544,109	7/57	Canada.
486,544	6/38	Great Britain.
700,593	12/53	Great Britain.
818,298	8/59	Great Britain.

FRANKLIN T. GARRETT, *Primary Examiner.*