

H. W. DICKINSON.

Cording Guide for Sewing Machines.

No. 12,858.

Patented May 15, 1855.

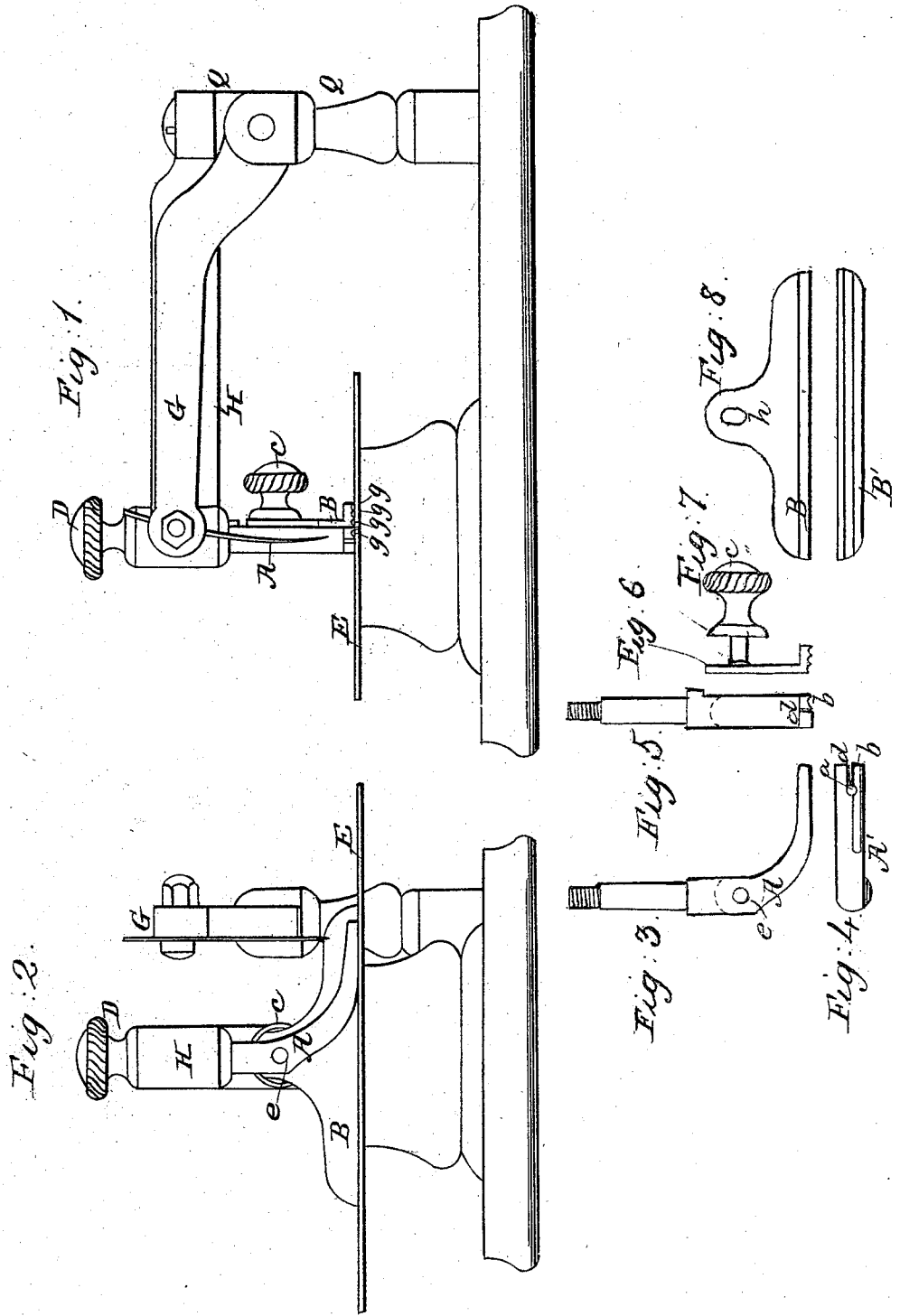

UNITED STATES PATENT OFFICE.

HENRY W. DICKINSON, OF HARTFORD, CONNECTICUT.

IMPROVEMENT IN CORDING-GUIDES FOR SEWING-MACHINES.

Specification forming part of Letters Patent No. 12,858, dated May 15, 1855.

To all whom it may concern:

Be it known that I, HENRY WHIPPLE DICKINSON, of the city and county of Hartford, in the State of Connecticut, have invented a new and useful improvement in sewing-machines, respecting that part which is used to confine cloth or other material while being sewed called the "holder;" and I do hereby declare the following to be a true and clear description thereof, reference being had to the drawings herewith presented, which also constitute a part of said description, viz:

The nature of this invention consists in constructing the holder in such a manner that a corded seam may be sewed as readily as ordinary plain stitching. A corded seam is usually made by sewing two rows of stitches and afterward drawing the cord through the fold between them—*i. e.*, the two rows of stitches; but by forming the holder as hereinafter described, the cord placed in its proper position is at once stitched in its place, and not only thereby facilitating operations, but producing a neater and more beautiful style of seam.

This improvement is not intended to be confined to any particular kind of machine, but to all as far as possible. The drawings represent it as it may be applied to Allen B. Wilson's patent stitching-machine.

Plate I, Figures 1 and 2 represent the position of this improved holder with regard to the plate E, upon which the work is laid when the machine is in operation, in a front and side elevation. The columns Q Q in Fig. 1 are merely to enable the portions of needle-bar G and holder-bar H represented to maintain their respective positions when detached from and divested of the operating machinery. In the drawings only a short portion of each are represented, the remaining parts, with feeding mechanism and machinery to operate the needle, make the stitch, &c., being unnecessary in the present description.

A is the holder, attached in the usual manner—*i. e.*, held in the bar H by the milled nut D—and made to bear upon plate E by means of a spring within H, Fig. 2; but this differs from the one in ordinary use, as will be seen in referring to Plate II. Fig. 3 is a front view

of A, detached from its place. Fig. 4 represents that part of A which bears upon the plate E. *a* is the hole through which the needle passes. The slot *d*, ordinarily running centrally to *a*, is made tangent, or nearly so, in order that it may in no way interfere with groove *b*, which is in so close proximity to *a* that the needle passes through the material into which a cord is to be stitched in such a manner that the cloth or material to be sewed may be drawn taut and fair over the cord. Fig. 5 shows at *b* the depth and shape of groove and position in regard to slot *d*. Fig. 6 is a side view of B, the back elevation of which is given in Fig. 8, the bearing-surface of which may be also grooved, in order to receive and act upon finished corded seams as a guide to the cloth in making the next seam that it may be parallel. Fig. 9 represents the under or bearing side of one having three grooves, the number of grooves being greater or less, as experience or conditions may dictate, their size depending upon that of the cord and thickness of material into which it may be stitched. B is made fast to the holder A by means of a small milled-headed screw, C, (shown in Fig. 7,) and, passing through an elongated opening, *h*, Fig. 8, screws into the holder A at point *e*, thereby firmly attaching it thereto, at the same time the opening *h* allowing the piece B to be adjusted.

I claim—

1. A holder or presser to a sewing-machine, formed with a groove to hold a cord in its place while being stitched into cloth or other material, for the purpose of forming a corded seam, in the manner described.

2. Forming the face or bearing side of an adjustable guide with grooves so arranged as to receive and act upon a finished corded seam and guide the cloth parallel while stitching another seam or sewing in another cord, as described.

Signed in presence of two subscribing witnesses.

HENRY WHIPPLE DICKINSON.

Witnesses:

CHARLES J. HOADLY,
HENRY K. W. WELCH.