

(No Model.)

4 Sheets—Sheet 1.

H. M. BURDICK.  
CULTIVATOR.

No. 525,838.

Patented Sept. 11, 1894.

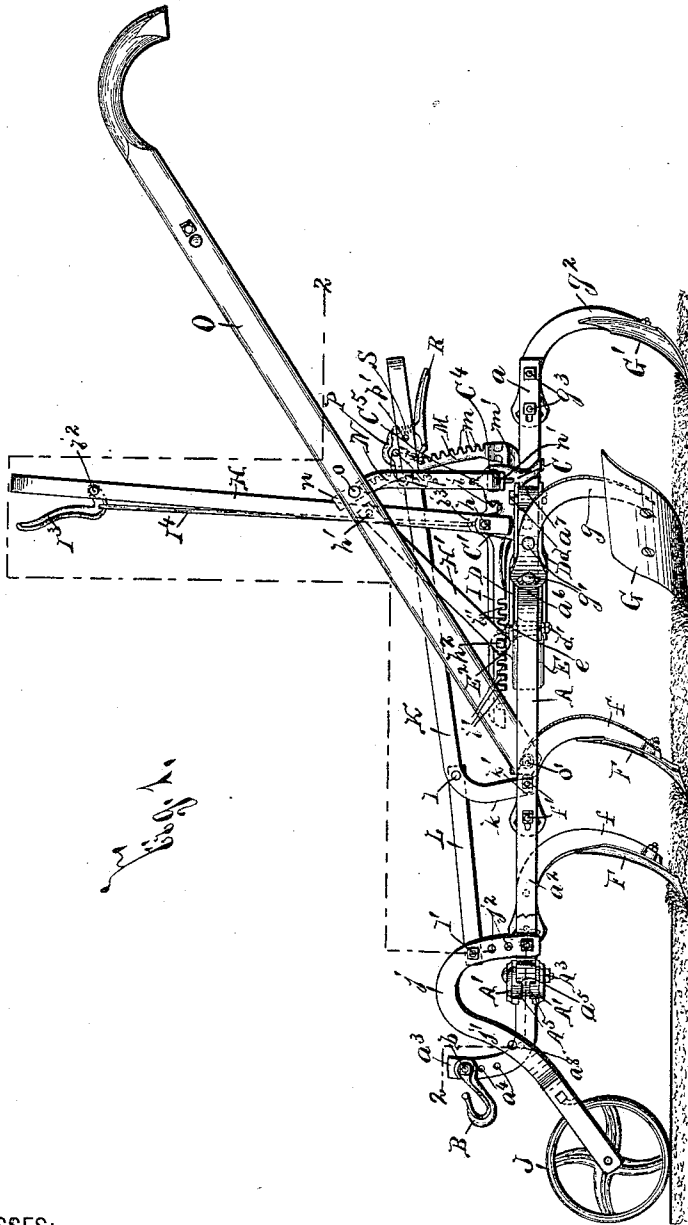

WITNESSES:

*H. C. Chase,*  
*L. Schoenck.*

INVENTOR

*iram M. Burdick*

BY

*Hay Wilkinson & Tamm*  
ATTORNEYS.



(No Model.)

4 Sheets—Sheet 3.

# H. M. BURDICK. CULTIVATOR.

No. 525,838.

Patented Sept. 11, 1894.

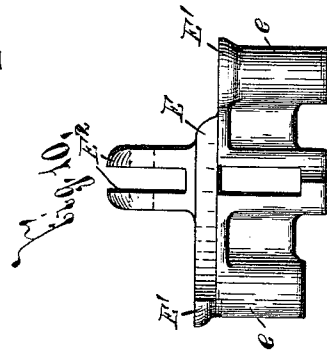
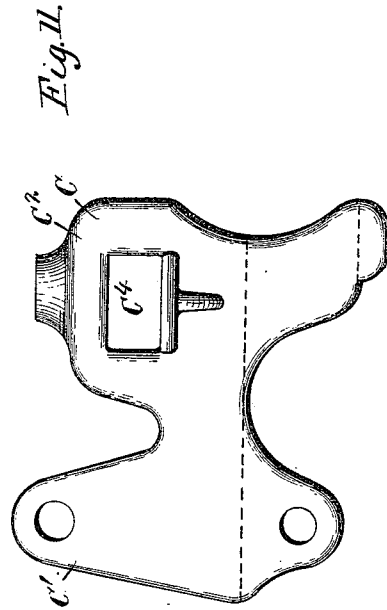
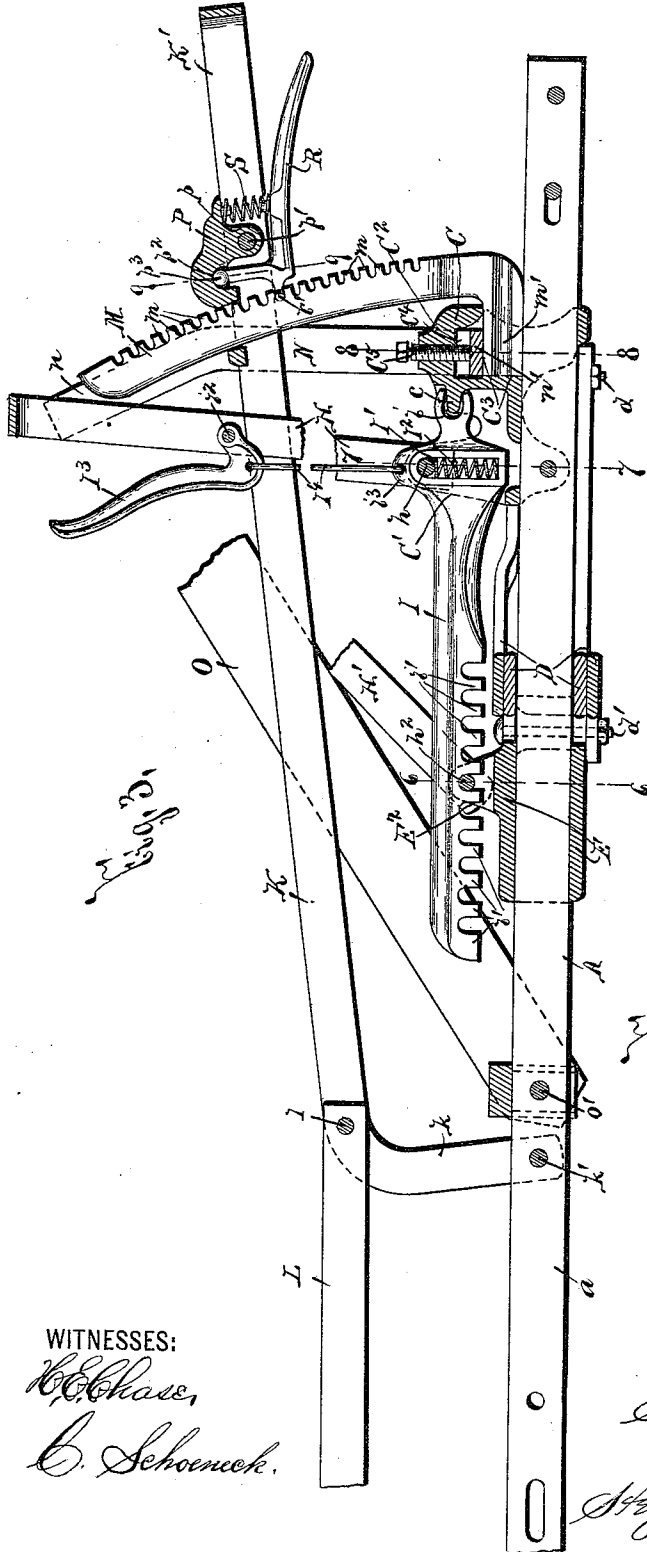

WITNESSES:

*H. C. Chase,*  
*C. Schoenck.*

INVENTOR.

*Hiram M. Burdick*

BY

*Wm. Wilkinson Parsons*  
ATTORNEYS.

(No Model.)

4 Sheets—Sheet 4.

# H. M. BURDICK, CULTIVATOR.

No. 525,838.

Patented Sept. 11, 1894.

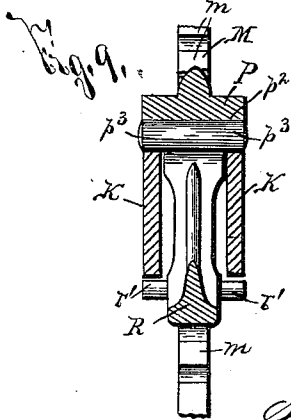
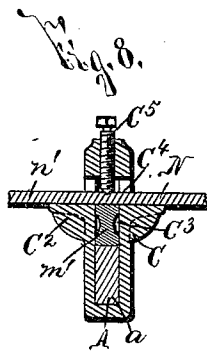
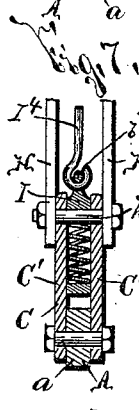
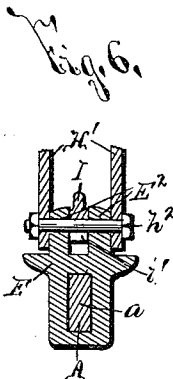
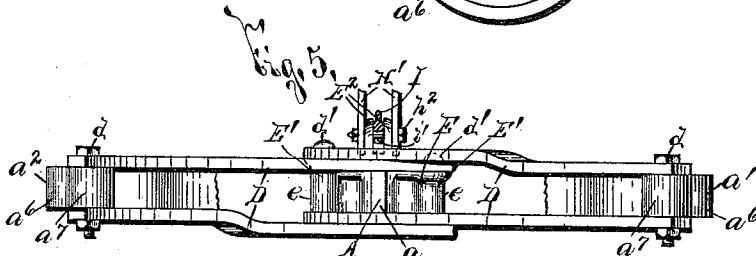
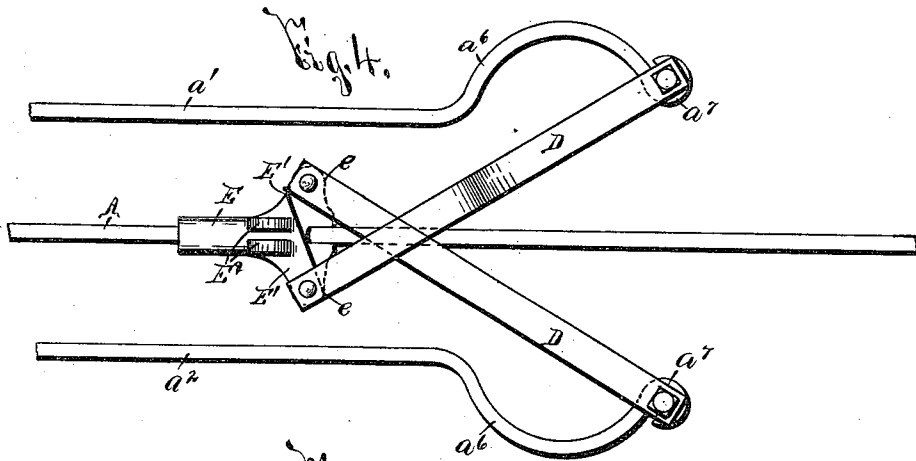

WITNESSES:

*H. C. Chase*  
*B. Schoenck*

INVENTOR

*Henry M. Burdick*

BY

*Steph. Williams & Parone*  
ATTORNEYS.

# UNITED STATES PATENT OFFICE.

HIRAM M. BURDICK, OF SYRACUSE, NEW YORK, ASSIGNOR TO THE SYRACUSE CHILLED PLOW COMPANY, OF SAME PLACE.

## CULTIVATOR.

SPECIFICATION forming part of Letters Patent No. 525,838, dated September 11, 1894.

Application filed August 22, 1892. Serial No. 443,688. (No model.)

*To all whom it may concern:*

Be it known that I, HIRAM M. BURDICK, of Syracuse, in the county of Onondaga, in the State of New York, have invented new and useful Improvements in Cultivators, of which the following, taken in connection with the accompanying drawings, is a full, clear, and exact description.

My invention relates to improvements in cultivators, and has for its object the production of a simple and effective device, which is particularly economical in manufacture, and practical and durable in use; and to this end it consists, essentially, in a frame having a central longitudinal bar and side frame bars on opposite sides of the former bar having their rear ends movable toward and away from each other, a head or block movable on the central frame bar, spreader bars having their outer ends hinged to the rear ends of the side frame bars, and their inner ends crossed and secured to said head, an actuating lever hinged to the frame, and a link hinged to the actuating lever and to said movable head.

The invention furthermore consists in a stationary head on the frame for supporting the actuating lever for the movable head, a locking lever having one end hinged to the stationary head and the other adapted to engage the movable head, an actuating lever for disengaging the locking lever, a land wheel actuating lever, a locking arm having a laterally extending end engaging with a recess in the stationary head, a locking dog on the land wheel actuating lever for engaging the upper end of said arm, a handle brace passed through said stationary head above the laterally extending end of the locking arm and clamped thereupon, and in the detail construction and arrangement of the parts, all as hereinafter more particularly described and pointed out in the claims.

In describing this invention, reference is had to the accompanying drawings, forming a part of this specification, in which, like letters indicate corresponding parts in all the views.

Figure 1 is a side elevation of my improved cultivator, illustrating the general arrangement and construction of the parts. Fig. 2 is an enlarged horizontal sectional view, taken

on line —2—2—, Fig. 1. Fig. 3 is an enlarged vertical sectional view, taken on line —3—3—, Fig. 2, the central portion of the movable head actuating lever being broken away. Fig. 4 is a top plan view of the detached rear ends of the frame bars shown as in their position assumed when approximated, the spreader bars, and the movable head for the spreader bars. Fig. 5 is a rear elevation, partly in section, of the parts as shown at Fig. 4. Figs. 6, 7, 8, and 9 are detail vertical sectional views, taken respectively on the section lines —6—6—, —7—7—, —8—8—, and —9—9—, Fig. 3, further illustrating the construction and arrangement of the parts. Fig. 10 is a detached rear elevation of the movable head on the central frame bar, and Fig. 11 is a side elevation of the detached stationary head on said frame bar.

—A— represents the frame of my cultivator, here shown as composed of a central bar —a— and side bars —a'—a<sup>2</sup>— on opposite sides of the bar —a—. The central bar —a— is formed with an upturned arm —a<sup>3</sup>— provided with a series of perforations —a<sup>4</sup>— for receiving a bolt —b— that secures a clevis —B— to the arm —a<sup>3</sup>—. Suitably mounted upon the rear end of the bar —a— is a stationary head —C— and directly in advance of the head —C— is a head —E—, which is also suitably mounted on the bar —a— and is movable toward and away from the head —C—.

—A'—A'— are clip plates arranged above and below the forward end of the central bar —a— at the rear of its upturned arm —a<sup>3</sup>—. These clip plates cross the bar —a— at substantially right angles, and consequently their ends project laterally therefrom. Suitable shoulders —A<sup>2</sup>— on the adjacent faces of the plates —A'—A'— and clamps —A<sup>3</sup>—A<sup>3</sup>— prevent the disengagement of said plates and firmly secure them in position. Projecting from the adjacent faces of the plates —A'—A'— are rounding projections —A<sup>4</sup>—A<sup>4</sup>—, and in suitable proximity to these projections are rounding engaging shoulders —A<sup>5</sup>—A<sup>5</sup>—. The forward ends of the side frame bars —a'—a<sup>2</sup>— incline toward each other, and are formed with the laterally extending arms —a<sup>5</sup>—a<sup>5</sup>—, which are interposed between the rounding projections —A<sup>4</sup>—A<sup>4</sup>—

and the shoulders  $-A^5-A^5-$  of the corresponding ends of the clip plates  $-A'-A'-$ . Consequently these shoulders  $-A^5-A^5-$  and projections  $-A^4-A^4-$  secure the forward ends of the side frame bars to the clip bars  $-A'-A'-$ , and permit of a hinge movement of the forward end of said bars around the projections  $-A^5-A^5-$ . The rear ends of the bars  $-a'-a^2-$  are formed with the outwardly extending rounding faces  $-a^6-a^6-$  and with upright eyes  $-a^7-a^7-$  at the rear of said faces.

$-D-D-$  are spreader bars, which each consist of a pair of separated bars arranged one above the other. The outer or rear ends of the bars  $-D-D-$  are secured by bolts or other suitable clamps  $-d-d-$  to the eyes  $-a^7-a^7-$ , and their inner or front ends are crossed and secured by bolts or other clamps  $-d'-d'-$  to upright eyes  $-e-e-$ , which are formed upon arms  $-E'-E'-$  extending laterally from the opposite sides of the rear end of the movable head  $-E-$ .

As clearly seen at Figs. 4 and 5 the top bearing face of the right hand eye is lower than the corresponding bearing face of the left hand eye, and the lower bearing face of said right hand eye is lower than the corresponding bearing face of the other eye in order that the inner ends of the bars of the right hand spreader bar may cross above the corresponding ends of the bars of the left hand spreader bar. As also clearly seen at Fig. 5 the upper bar of the right hand spreader bar is formed with a downward deflection, and the lower bar of the left hand spreader bar with an upward deflection in order that the rear ends of the bars of each of said spreader bars may be separated only a distance corresponding to the height of the eyes  $-a^7-a^7-$ . The head  $-E-$ , as previously stated, is movable on the bar  $-a-$ , and, as it is forced forward or backward, the rear ends of the frame side bars  $-a'-a^2-$  are moved toward and away from each other, and their forward ends have a hinge movement upon the clip plates  $-A'-A'-$ .

$-F-F-$  are cultivator points, which are carried by suitable standards or shanks  $-f-f-$  having their upper ends adjustably secured by clamps  $-f'-f'-f'-f'-$  to the forward ends of the side frame bars  $-a'-a^2-$ .

$-G-G-$  are cultivator points of somewhat different form from the previous points  $-F-F-$ , and  $-g-g-$  are standards having their rear ends attached to said points  $-G-G-$  and their upper ends adjustably secured by bolts  $-g'-g'-g'-g'-$  to the rounding faces  $-a^6-a^6-$  of the rear ends of the bars  $-a'-a^2-$ .

$-G'-$  is a central rear cultivator point attached or fastened to the lower end of a shank  $-g^2-$  having its upper end secured by clamps  $-g^3-$  to the rear end of the central frame bar  $-a-$ .

$-H-$  is an actuating lever for forcing the head  $-E-$  forward and backward to ap-

proximate and separate the rear ends of the frame bars  $-a'-a^2-$ . This lever is preferably formed of a strip of sheet metal folded upon itself, and consequently consists of a pair of separated substantially parallel bars or legs joined at their upper or free extremity. The lower end of the lever  $-H-$  is secured by a pivotal pin or bolt  $-h-$  to separated ears  $-C'-C'-$  at the forward extremity of the head  $-C-$ .

$-H'-$  is a link formed also of a folded strip of sheet metal and composed of a pair of separated bars having their rear ends connected. The upper or rear end of the link  $-H'-$  is hinged at  $-h'-$  to the lever  $-H-$  and its other end is hinged at  $-h^2-$  to ears  $-E^2-E^2-$  upon the top face of the head  $-E-$ . As the upper end of the lever  $-H-$  is forced forwardly and backwardly the head  $-E-$  is positively and effectively moved in the same direction, and, as is evident, this peculiar construction of lever  $-H-$  and link or connection  $-H'-$  is particularly economical, light, strong, and durable.

$-I-$  is a locking lever or bar for holding the head  $-E-$  in its adjusted position. The rear end of the locking lever or bar is, as best seen at Fig. 3, formed with an inwardly extending groove or cut out  $-i-$  of less width at its outer edge for receiving a forwardly projecting rib or bar  $-c-$  on the front face of the head  $-C-$ , and the under face of the front end of the locking lever or bar  $-I-$  is formed with a series of teeth  $-i'-$  for engaging the pivotal pin  $-h^2-$  secured in the ears  $-E^2-E^2-$ . The rear end of the locking lever  $-I-$  is arranged between the separate bars of the actuating lever  $-H-$ , and its forward end is arranged between the bars of the link or connection  $-H'-$  and the ears  $-E^2-E^2-$ . Consequently the locking lever  $-I-$  is formed at its rear end with a transverse slot  $-I'-$  for receiving the pivotal bolt  $-h-$  of the lever  $-H-$ . A suitable spring  $-I^2-$  is arranged within this slot  $-I'-$  with one end bearing against the under face of the bolt  $-h-$  and the other against the opposite wall of the slot  $-I'-$ .

$-I^3-$  is an actuating lever pivoted at  $-i^2-$  to the upper end of the actuating lever  $-H-$ , as best seen at Figs. 1, 2, and 3.

$-I^4-$  is a connection or link formed of wire or other suitable material having one end hinged to the actuating lever  $-I^3-$  and the other passed between the bars of the actuating lever  $-H-$  and the connection  $-H'-$  and hinged to an ear  $-i^3-$  arranged directly above the slot  $-I'-$ . As the upper end of the lever  $-I^3-$  is forced toward the adjacent end of the lever  $-H-$  the connection  $-I^4-$  pulls the locking lever  $-I-$  upwardly against the action of the spring  $-I^2-$ , and disengages its forward end from the head  $-E-$  for permitting adjustable movement of said head.

The described construction and arrangement of the locking lever, its actuating lever, and the connections between the two are par-

ticularly economical in manufacture, and practical and simple in operation, and, as will be readily apparent to one skilled in the art, the natural closing of the hand to engage the upper end of the lever —H— draws the lever —I<sup>3</sup>— into position to disengage the locking lever from the head to permit its movement by said lever —H—.

—J— is the land wheel, and —j— its support or standard, which also consists of a pair of separate bars.

—j'— is an opening extending through the support —j— and adapted to register with an opening —a<sup>3</sup>— at the base of the arm —a<sup>3</sup>—, previously described. The rear end of the support or standard —j— is curved downwardly in a plane concentric with the opening —j'—, and is formed with a series of perforations —j<sup>2</sup>—. A bolt —j<sup>3</sup>— passes through the lower perforation —j<sup>2</sup>— and the central frame bar —a—, thus pivoting the rear end of the land wheel support or standard to the frame.

—K— is an actuating lever for raising and lowering the land wheel by rocking its support or standard backwardly or forwardly. This lever also consists, preferably, of a bar folded upon itself, and consisting of a pair of substantially parallel bars joined at their rear ends and at their forward ends with a downturned lateral arm —k— pivoted at —k'— to the central frame bar —a—. A link —L— is pivoted at —l— to the lever —K—, and is hinged by a bolt —l'— to the upper perforation —j<sup>2</sup>—.

—M— is a locking arm or rack having its rear face disposed in a plane concentric with the pivot —k'— of the lever —K— and formed with engaging teeth —m—. At the lower end of the arm —M— is a laterally extending lug —m'—, which enters a recess —C<sup>3</sup>— opening inwardly from the rear face of the head —C—.

—N— is the handle brace, which consists of upright arms —n—n— and a connecting bar —n'— between the lower ends of the arms. This bar is passed through a slot —C<sup>4</sup>— extending through the two opposite faces of the head —C— and arranged directly above the lug —m'—. Consequently the bar —n'— rests upon the top face of the lug —m'—, and is firmly forced thereagainst by a clamp or screw —C<sup>5</sup>— bearing against the upper face of said bar for firmly retaining in operative position both the handle brace —N— and the locking arm —M—. Suitable handles —O—O— are secured at —o— to the upper ends of the handle brace arms —n—n—, and are also secured at their lower ends by a bolt —o'— to the central frame bar —a—. Since the lever —K—, as previously stated, is composed of a folded bar, it is consequently formed with a lengthwise slot or opening —K'— extending through its upper and lower edges between the separated bars of said lever. Mounted upon the top face of the rear end of the lever —K— is a cap —P—, which is

formed with an ear —p— that enters the slot —K'—, and is secured to the lever by a rivet or other fastening means —p'—. The under face of this cap —P—, which rests against the top edges of the bars forming the lever —K— is provided with a groove or cut-out —p<sup>2</sup>—.

—R— is a dog having one end inserted within the slot —K'— beneath the cap —P— and provided with laterally extending arms —p<sup>3</sup>—, which are mounted in the groove —p<sup>2</sup>— that forms a bearing therefor, and rest upon the top edges of the separate bars of the lever —K—. A suitable spring —S— is interposed between the rear end of the cap —P— and the lever —R— for constantly forcing the rear end of said lever —R— away from the lever —K—. At the forward end of the dog —R— is a rounding laterally extending rib —r'— adapted to engage the teeth of the upright arm —M— for locking the lever —K— to said arm. This rib is of sufficient length so that its ends bear against the under side of the lever —K— and form a stop for limiting the separation of the rear end of the dog —R— from the corresponding end of the lever —K—. As the lever —K— is raised and lowered the land wheel is readily adjusted, and by means of the dog —R— said lever is firmly held in its adjusted position. Moreover the parts of this land wheel adjusting mechanism are particularly simple, practical, and effective.

Upon reference to the foregoing description and the accompanying drawings, it will be readily noted that the rear ends of the side frame bars are readily adjusted toward and away from each other, and are then firmly held in their adjusted position, owing to the crossing of the inner ends of the spreader bars and the engagement of the locking lever or bar with the movable head carrying the spreader bars; that the land wheel is also readily adjusted and firmly held in position, and that the parts of my invention are extremely practical in construction and operation, are readily assembled, and durable in use. It is evident, however, that the detail construction and arrangement of these parts may be somewhat varied without departing from the spirit of my invention.

Having thus fully described my invention, what I claim as new, and desire to secure by Letters Patent, is—

1. In a cultivator, the combination of central and side frame bars; with spreader bars between the frame bars having their adjacent ends crossed and the extremities of said ends extended on opposite sides of the point of intersection of the spreader bars, and connected to the central frame bar, substantially as set forth.

2. In a cultivator, the combination of central and side frame bars, and a movable head on the central bar provided with lateral arms; with spreader bars between the frame bars having their adjacent ends crossed and the

extremities of said ends extended on opposite sides of the point of intersection of the spreader bars and pivoted to said lateral arms, substantially as and for the purpose described.

3. In a cultivator, the combination of central and side frame bars, and a movable head on the central bar provided with bearing faces arranged one above the other; with spreader bars between the frame bars having their adjacent ends crossed and the extremities of said ends extended on opposite sides of the point of intersection of the spreader bars and pivoted to said bearing faces, substantially as and for the purpose set forth.

4. In a cultivator, the combination of frame bars and a movable head; with a movable locking lever or bar having one end hinged to the frame and the other end engaged with said head, substantially as and for the purpose specified.

5. In a cultivator, the combination of frame bars, a movable head and a lever for actuating said head; with a movable locking lever or bar having one end hinged to the frame and the other end engaged with said head, a second actuating lever pivoted to the former lever, and a link connecting the locking lever and the second actuating lever, substantially as and for the purpose described.

6. In a cultivator, the combination of frame bars, a fixed head and a movable head; with a link for actuating the movable head consisting of a pair of separated bars and a movable locking lever or bar having one end hinged to the fixed head and the other end movable between the separated bars of said link and engaged with the movable head, substantially as and for the purpose set forth.

7. In a cultivator, the combination of frame bars and a movable head; with a movable locking lever or bar having one end hinged to the frame and the other end engaged with said head and having an intermediate portion provided with a transverse slot, a pin inserted within said slot, and a spring engaged with said locking lever and pin, for forcing the locking lever to operative position, substantially as and for the purpose described.

8. In a cultivator, the combination of frame bars, a fixed head provided with an engaging rib or bar, and a movable head; with a movable locking lever having one end formed with an inwardly extending groove or cutout for receiving said rib or bar and having its opposite end provided with a series of teeth for engaging the movable head, and a spring for forcing the locking lever to its operative position, substantially as and for the purpose specified.

9. In a cultivator, the combination of central and side frame bars, and a movable head on the central bar provided with lateral arms and formed with upright eyes; with spreader bars between the frame bars having their adjacent ends crossed and the extremities of said ends pivoted to said eyes, and a locking

lever or bar having one end hinged to the frame and the other end engaged with said head, substantially as and for the purpose described.

10. In a cultivator, the combination of a central frame bar, clip plates above and below the front extremity of the central bar having their opposite ends projecting laterally from said bar and formed with pivotal projections and shoulders, side frame bars having their rear ends formed with convex surfaces and their front ends provided with inwardly rounded arms engaged with said projections, standards formed with curved ends engaged with said rounded faces at the rear end of the side frame bars, a head upon the central frame bar, and spreader bars having their outer or rear ends secured to the corresponding end of the side frame bars and their front ends crossed and secured to said head, substantially as specified.

11. In a cultivator, the combination of a land wheel support hinged to the frame, an actuating lever having a lateral downturned arm hinged to the frame, and a connection arranged above the lower extremity of the downturned lateral arm of the actuating lever, and having one extremity pivoted to the land wheel support and the other extremity pivoted to the actuating lever, substantially as and for the purpose set forth.

12. In a cultivator, the combination of a land wheel support having an aperture  $j'$  and a series of apertures  $j''$  arranged concentric with the aperture  $j'$ , a pivot for one of said apertures, an actuating lever and a connection having one extremity pivoted to the land wheel support and the other extremity pivoted to the actuating lever, substantially as specified.

13. In combination, an actuating lever formed with a slot extending through two opposite sides, a plate or cap secured at one side of said slot and formed with bearing openings in its face adjacent to the actuating lever and a locking dog having one end mounted in said slot and provided with laterally extending arms mounted in said bearing openings and upon the adjacent face of the lever, substantially as specified.

14. In combination, an actuating lever formed with a slot extending through two opposite sides, a plate or cap supported upon one of said sides and formed with an ear secured to the lever and with bearing openings in its face adjacent to the actuating lever, a locking dog having one end mounted within the slot and provided with laterally extending arms mounted in said bearing openings and upon the adjacent face of the lever, a spring bearing against said dog for forcing its opposite end outward from the lever, and a laterally extending lug on the dog bearing against the opposite face of the lever for limiting the movement of the dog, substantially as specified.

15. In a cultivator, the combination of a

frame, a land wheel, a land wheel support hinged to the frame, an actuating lever above the frame having one end hinged to the frame and the other formed with a slot extending  
 5 through two opposite sides, a connection between said actuating lever and the wheel support, an upright arm secured to the frame and formed with engaging teeth, a cap or plate secured to the end of the actuating lever  
 10 and formed with openings in its under face, a locking dog mounted in the slot in the actuating lever and provided with laterally extending lugs registered with the openings in the cap and bearing upon opposite sides of  
 15 the slot, and a spring engaging said dog for forcing the same into engagement with said upright arm, substantially as specified.

16. In a cultivator, the combination of a movable actuating lever provided with a locking dog; with a fixed head having a recess therein, a locking arm or rack for said locking dog having a laterally extending lug inserted within said recess and a clamp for holding the locking arm or rack in operative

position, substantially as and for the purpose 25 described.

17. In a cultivator, the combination of a movable actuating lever provided with a locking dog; with a fixed head having a transverse slot therein and a recess opening into  
 30 the slot, a locking arm or rack for said locking dog having a laterally extending lug inserted within said recess, a handle brace passed through said slot and engaged with the lug of the locking arm or rack, and a clamp for  
 35 holding said brace, and locking arm in position, substantially as and for the purpose described.

In testimony whereof I have hereunto signed my name, in the presence of two attest- 40  
 ing witnesses, at Syracuse, in the county of Onondaga, in the State of New York, this 16th day of August, 1892.

HIRAM M. BURDICK.

Witnesses:

W. W. WIARD,  
 C. A. CHASE.