

(51) International Patent Classification⁶ :

A61B 17/17

A1

(11) International Publication Number:

WO 96/03085

(43) International Publication Date:

8 February 1996 (08.02.96)

(21) International Application Number: PCT/IB95/00552

(22) International Filing Date: 12 July 1995 (12.07.95)

(30) Priority Data:

VR94A000069 28 July 1994 (28.07.94) IT

(71) Applicant (for all designated States except US): ORTHOFIX S.R.L. [IT/IT]; Via delle Nazioni, 9, I-37012 Bussolengo (IT).

(72) Inventors; and

(75) Inventors/Applicants (for US only): FACCIOLI, Giovanni [IT/IT]; Via Europa, 19, I-46040 Monzambano (IT). ROSSI, Stefano [IT/IT]; Via Sacchi, 7, I-37124 Verona (IT). OPPENHEIM, William [US/US]; 31 Forest Lane, Short Hills, NJ 07078 (US).

(74) Agent: EDWARD EVANS & CO.; Chancery House, 53-64 Chancery Lane, London WC2A 1SD (GB).

(81) Designated States: AM, AT, AU, BB, BG, BR, BY, CA, CH, CN, CZ, DE, DK, EE, ES, FI, GB, GE, HU, IS, JP, KE, KG, KP, KR, KZ, LK, LR, LT, LU, LV, MD, MG, MN, MW, MX, NO, NZ, PL, PT, RO, RU, SD, SE, SG, SI, SK, TJ, TM, TT, UA, UG, US, UZ, VN, European patent (AT, BE, CH, DE, DK, ES, FR, GB, GR, IE, IT, LU, MC, NL, PT, SE), OAPI patent (BF, BJ, CF, CG, CI, CM, GA, GN, ML, MR, NE, SN, TD, TG), ARIPO patent (KE, MW, SD, SZ, UG).

Published

With international search report.

(54) Title: DEVICE FOR MECHANICAL ALIGNMENT OF BONE SCREWS IN A MEDULLARY NAIL

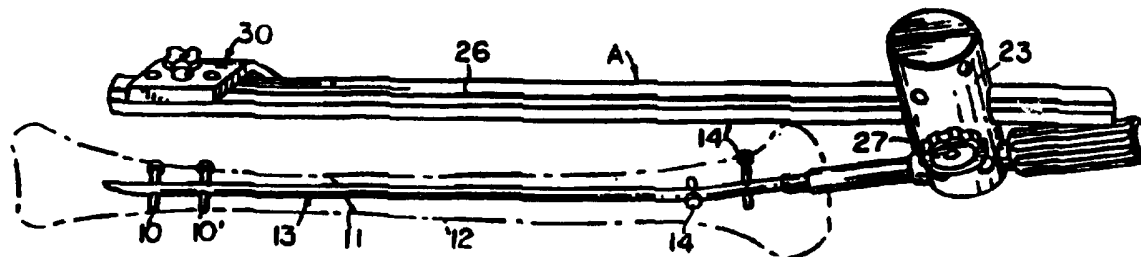

(57) Abstract

A drill jig for mechanically aligning a drill guide with one or more transverse bone-screw holes of an intramedullary nail (13) that is installed in an elongate fractured bone, such as a femur or tibia, wherein the intramedullary nail has at least a straight distally extending portion (15), a proximal end (17) adapted for jig attachment and one or more bone-screw holes (18, 18') in said straight distally extending portion, said one or more holes and the axis of the nail defining a first geometric plane of symmetry, said jig comprising: an elongate straight guide bar (26); a rigid handle (23) having means for keyed selective connection to the proximal end of the nail so that said handle extends transversely of the nail and means for guiding and retaining said guide bar parallel to the nail; one or more drill-guide bores in general alignment with said one or more bone screw holes; characterized in that it comprises an outrigger structure (30) removably carried by said guide bar and extending laterally outwardly of said first geometric plane, said outrigger structure having an end with a guide bore in a second geometric plane which includes the axis of said nail and is perpendicular to said first geometric plane, and a spacer rod (35) adapted for mounting to the guide bore of said outrigger structure with such effective projecting length therefrom to contact said nail when the one or more drill-guide bores of said guide bar are truly aligned with the one or more holes of said nail.

FOR THE PURPOSES OF INFORMATION ONLY

Codes used to identify States party to the PCT on the front pages of pamphlets publishing international applications under the PCT.

AT	Austria	GB	United Kingdom	MR	Mauritania
AU	Australia	GE	Georgia	MW	Malawi
BB	Barbados	GN	Guinea	NE	Niger
BE	Belgium	GR	Greece	NL	Netherlands
BF	Burkina Faso	HU	Hungary	NO	Norway
BG	Bulgaria	IE	Ireland	NZ	New Zealand
BJ	Benin	IT	Italy	PL	Poland
BR	Brazil	JP	Japan	PT	Portugal
BY	Belarus	KE	Kenya	RO	Romania
CA	Canada	KG	Kyrgyzstan	RU	Russian Federation
CF	Central African Republic	KP	Democratic People's Republic of Korea	SD	Sudan
CG	Congo	KR	Republic of Korea	SE	Sweden
CH	Switzerland	KZ	Kazakhstan	SI	Slovenia
CI	Côte d'Ivoire	LI	Liechtenstein	SK	Slovakia
CM	Cameroon	LK	Sri Lanka	SN	Senegal
CN	China	LU	Luxembourg	TD	Chad
CS	Czechoslovakia	LV	Latvia	TG	Togo
CZ	Czech Republic	MC	Monaco	TJ	Tajikistan
DE	Germany	MD	Republic of Moldova	TT	Trinidad and Tobago
DK	Denmark	MG	Madagascar	UA	Ukraine
ES	Spain	ML	Mali	US	United States of America
FI	Finland	MN	Mongolia	UZ	Uzbekistan
FR	France			VN	Viet Nam
GA	Gabon				

DEVICE FOR MECHANICAL ALIGNMENT OF BONE SCREWS IN
A MEDULLARY NAIL

The invention relates to a jig system adapted for connection to an intramedullary nail, wherein the intramedullary nail is implanted in a fractured long bone, such as a tibia or femur the implantation being such as to have the nail extend distally and proximally with respect to the fracture, in reinforcement of fractured parts of the bone that have been re-aligned or merely are to be held in alignment for the course of healing repair.

Intramedullary nails of the character indicated are either solid or hollow, but they are customarily prepared with two spaced parallel holes that extend diametrically across the nail near the distal end of the nail and with two spaced holes of similar nature, but not necessarily parallel, near the proximal end of the nail. These holes are formed to accept bone screws and when the nail has been installed, its bone-screw holes are said to be "blind" in terms of the bone-drilling alignment that must be achieved. The problem has always been one of assuring correct alignment for drilling to accept a bone screw driven through bone for anchoring passage through the intramedullary nail. The traditional technique for assuring blind drill alignment with the bone-screw holes of an intramedullary nail involves use of x-rays, which of course pose well-known dangers from cumulative exposure; and to assure adequate safety for operating personnel, the use of x-rays is, to say the least, cumbersome, thus contributing to the expense of a good intramedullary-nail installation.

The proximal end of the nail is formed for anti-rotational keyed and detachably fixed connection to jig structure that is intended to aid in orientation of drill guides in the hope of achieving a correct alignment with

each drill hole, the customary technique of ascertaining alignment being by use of x-rays.

One of the problems of locating a bone-screw hole in an installed intramedullary nail is the practical fact that the nail may have undergone a slight bend in the course of implantation, so that such holes at the distal end of the nail no longer have precisely the same location with respect to the proximal end, as was the case prior to nail implantation. Thus, any jig structure connected to the proximal end has had to rely on x-rays for assurance of alignment.

In an effort to avoid x-ray dependence in solving the problem of locating blind bone-screw holes in an installed intramedullary nail, U.S. Patent 5,281,224 and pending U.S. application Serial No. 08/121,762 have proposed magnetic detection, in the scanning displacement of a detection system across the distal region of an installed nail, to locate the central axis of the nail; but in the present state of development, such techniques have been clinically awkward, achieving less than the accuracy that is required.

It is an object of the invention to provide an improved system of blind-hole location for the case of an installed intramedullary nail.

Another object is to meet the above object with a purely mechanical system and technique which does not require use of x-radiation.

A further object is to meet the above objects with a system which enables faster operations, with assurance of correct alignment of bone drilling with the bone-screw holes of an installed nail, particularly at or near the distal end of the nail.

The invention achieves these object and further features of novelty in a blind-hole locating system wherein a drill jig, which is to be removably attached to the proximal end of a given intramedullary nail, incorporates outrigger structure for support and orientation of one or more drill guides, such that positioning and alignment with one or more bone-screw holes of the nail can be checked and ascertained as a preliminary step, and such that a precise spacer or stabilizer carried by this jig can be known to contact the nail, on an alignment transverse to the nail and to a geometric plane which includes the nail axis and the axis of at least one of the bone-screw holes of the nail, such stabilizer contact being achieved only for the case of correct drill-guide alignment with one or more bone-screw holes. Having thus ascertained that the spacer correctly identifies drill-guide alignment with bone-screw holes, it is only necessary, after installing the nail and connecting the jig to the proximal end of the nail, to make a small local surgical incision through flesh and bone sufficient to enable direct stabilizer contact with the nail, where upon it is known that the drill guides are in correctly drillable alignment with the targeted bone-screw holes of the installed nail. Drilling and setting of bone screws can immediately proceed in customary manner.

The invention will be described in detail for preferred embodiments having particular application to a tibial fracture, the description being in conjunction with the accompanying drawings, in which:

Fig. 1 is a simplified perspective view from above and to one side of an intramedullary nail and connected jig structure of the invention, showing distal and proximal nails that have been installed in a fractured tibia, the tibia being shown in phantom outline, and flesh profiles being omitted in the drawing;

Fig. 2 is an enlarged view in side elevation of the jig and nail of Fig. 1, partly broken-away to provide greater detail of distal and proximal coaction between nail and jig components;

Fig. 3 is a further enlarged section of distal outrigger structure of Fig. 2, taken at 3-3 of Fig. 2;

Fig. 4 is another view, to the scale of Fig. 3 and in partial section taken at 4-4 of Fig. 2, to shown stabilizer structure of Fig. 2;

Fig. 5 is a view in side elevation and to a still-further enlarged scale, for a nail-size compensation component of the jig in Fig. 2;

Fig. 6 is a top view of the nail-size compensation component of Fig. 5;

Fig. 7 is a left-end view in elevation of the component of Fig. 5;

Fig. 8 is a perspective view of coacting parts of the distal end of Fig. 2, in readiness for correctly aligned drilling for bone-screw anchorage to blind holes of the installed intramedullary nail of Fig. 2;

Fig. 9 is a view similar to Fig. 1, for the same jig but different outrigger structure used to install two longitudinally spaced bone screws at mutually divergent orientations through bone, at the proximal end of the intramedullary nail of Fig. 2;

Fig. 10 is an enlarged view in perspective to show greater detail of outrigger, drill-guide and jig structure at the proximal end of the system;

Fig. 11 is a view similar to Fig. 3 to show a modification, the viewing aspect being opposite to that of Fig. 3; and

Fig. 12 is a perspective view of the modification of Fig. 11, taken from a three-quarter aspect on the distal end of the modification.

Fig. 13 is a perspective view of a jig that is similar to Fig. 2, for the case of modified structure that is specifically useful in application to a fractured femur;

Fig. 14 is a perspective view similar to Fig. 12, showing the distal end of outrigger structure of Fig. 13; and

Fig. 15 is a fragmentary side elevation in partial section for stabilizer-rod positioning structure for the embodiment of Figs. 13 and 14.

In Fig. 1, the invention is seen as a jig structure, generally designated A, after having completed its job of correctly aligning, drilling and enabling installation of two bone screws 10, 10' at a location distal to a fracture 11 in a tibia 12 which has been reinforced by an elongate intramedullary nail 13; the bone screws 10, 10' will be understood to pass through spaced parallel bone-screw holes extending diametrically through nail 13. Two further bone screws 14, 14' are shown installed near the proximal end of the nail; the drilling for accommodation of bone screws 14, 14' is accomplished pursuant to later description, in connection with Figs. 9 and 10.

The jig structure A comprises a plurality of separably and adjustably connectable components, better seen and identified in Fig. 2, where the intramedullary nail 13 is shown to comprise an elongate straight distally extending portion 15 for most of its length, there being a short bend 16 at an acute angle α near the proximal end 17 of the nail; two spaced diametrically extending bone-screw holes 18, 18' in the bent proximal end 17 are for accommodation of the screws 14, 14' to be described later in connection with Figs. 9 and 10. The distal bone-screw holes (as at 19 in fig. 3) for bone screws 10, 10' will be understood to define a first geometric plane of symmetry. The bend 16 between otherwise straight distal (15) and proximal (17) portions of nail 13 will be understood to define another plane of symmetry which is normal to the first geometric plane of symmetry and will be referred to as the sagittal plane, containing the bent axis of the nail.

The proximal end of nail 13 has keyed fit to jig A via the chuck 20 of an elongate locking rod 21, which is clamped by bolts 22 between front and back

halves of a handle 23. A knob 24 is rotatable to releasably secure the engagement of jig structure in accurately keyed relation to the proximal end of the nail. As thus clamped and engaged to the nail, the central axis 23' of handle 23 extends at a right angle to the axis of the proximal end 17 of the nail, and this central axis 23' lies in the sagittal plane of the connected nail.

Confronting faces of the bolted halves of handle 23 are grooved to establish a central axis 25 for slant-guided alignment of an elongate guide bar 26, wherein the central axis 25 of bar 26 intersects the central axis 23' of handle 23 and wherein axis 25 is also contained within the same sagittal plane of the nail; the slant angle β of intersection of axes 23', 25 is the complement of angle α , so that guide bar 26 is necessarily parallel to the elongate distal end portion 15 of the intramedullary nail. The cross-sections of guide bar 26 and of the handle grooving to accommodate bar 26 are non-circular and preferably rectangular, with a height dimension H which exceeds its width dimension W, suitably by about 25 percent, as seen in Fig. 3, wherein corners of the section are bevelled. A locking knob 27 carried by handle 23 includes a dowel portion which is selectively enterable in a given one out of a plurality of spaced transverse openings 28 in bar 26, the selection among openings 28 being dependent upon the length of the particular intramedullary nail 13 selected for implantation. It is preferred that openings 28 be of limited depth in bar 26 and that the bottom of each opening 28 be conical, so that with a conically-tipped dowel secured by locking knob 27, the cone-to-cone engagement will assure an accurate, play-free location of handle 23.

Distal outrigger structure 30 is removably carried by guide bar 26 near the distal end of bar 26, to provide such lateral and downward offset of its lower end, from bar 26 and away from the sagittal plane, as to enable precise spaced parallel orientation and clamping of two elongate drill guides 31, in alignment

with each of the respective bone-screw holes 19 near the distal end of the nail 13, all as best seen in Fig. 3; a knob 31' enables clamped positioning of the drill guides 31 to the laterally offset end of outrigger 30. For accuracy in establishing the indicated offset, the upper end of outrigger 30 mounts two spaced dowels 32 having precision entry in vertical guide bores through guide bar 26, and outrigger 30 is securely clamped by a knob-driven locking bolt 33 engaged to a suitably tapped vertical bore in guide bar 26, located between the two dowel pins. The vertical orientation of dowel pins 32 and of the guide bar 26 symmetrically with respect to the sagittal plane S of nail 13 is clear from Fig. 3 and its legends.

A further important component of the jig of Fig. 2 is an elongate spacer or stabilizer rod 35, having a manipulating handle 36 at its upper end. For most of its length, rod 35 is of constant diameter for guided stability in a vertical bore 37 in guide bar 26, in spaced adjacency to the mounting of outrigger 30. At its lower end, the diameter of rod 35 is reduced to define a cylindrical portion 38 of length L which, as will later be explained, must be passed through a small surgical incision of flesh and local drilling of bone, to permit lower-end contact, as shown, with nail 13.

The stabilizer rod 35 is designed for precise positioning of its lower end with respect to guide bar 26 when in contact with nail 13, namely, when each drill guide 31 is truly aligned with a bone-screw hole 19 in the nail. To this end, spaced upper and lower circumferential grooves 39, 39' are formed in rod 35, and each of these grooves straddles upper and lower intercepts of rod 35 with the respective upper and lower faces of the rectangular section of guide bar 26. A shim 40 in the form of a clip is laterally applicable to guide bar 26, with provision for entry into the respective grooves 39, 39', to thereby limit the extent to which the lower end of stabilizer rod 35 can be projected toward nail

13. More detail as to shim 40 is obtained by further reference to the respective views of Figs. 5, 6, and 7.

As viewed from the aspect shown in Fig. 4, and as more particularly seen in Fig. 5, the shim 40 is of generally C-shape, being characterized upper and lower jaws 41, 42 which have vertically aligned side-entry slots 43, 43', of width less than the diameter of rod 35. Jaws 41, 42 extend integrally from a body 44 having upper and lower finger-grip recesses 45, 45' and also having a central through-hole 46 for tool-assisted removal from guide bar 26, if necessary. Inner-wall surfaces 41', 42', 44' of the C-shape are formed for unambiguous stabilizing engagement to corresponding sides of the section of guide bar 26. A spring detent 47 has snap-engagement to the rod groove 39' upon application of shim 40 to guide bar 26, when rod 35 is positioned as shown in Fig. 4 to accept entry of the jaws 41, 42 into the respective grooves 39, 39'. When thus engaged, with the bottoms of grooves 39, 39' nested in the arcuate closed ends of slots 43, 43', the central axis of stabilizer rod 35 will be in the alignment marked S in Fig. 5, signifying rod-35 inclusion in the same sagittal plane as has been elsewhere indicated for other components of the jig system.

The word "shim" has been used for the component just described in connection with Figs. 5, 6 and 7 because the thickness "T" shown in Fig. 5 is uniquely designed to position the lower end of stabilizer rod 35 at contact with nail 13, when drill guides are correctly aligned with respect to the distal bone-screw holes of the nail. But the precise thickness T will apply only for one of a series of possible section diameters of intramedullary nail. In the form shown, a 9-mm diameter nail 13 calls for a bottom-positioning limit for rod 35 that is unique, and therefore the thickness T in Fig. 5 is unique for tibia use with a 9-mm diameter nail. The unique limit of downward projection of

bottom or tip end of rod 35 occurs when the upper surface of jaw 41 interferes with the upper shoulder or wall of upper groove 39 of rod 35. Any further attempted depression of rod 35 will drive the shim thickness T of jaw 41 squarely against the flat upper surface of guide bar 26, tending to bend bar 26 if the force is great enough, but never spoiling the correctly spaced distance of nail 13 beneath bar 26, it being noted that any bend of bar 26 is not only accompanied by correctly spaced deflection of nail 13 but also by similarly correct displacement of the drill guides carried by outrigger 30.

It will be helpful briefly to outline steps taken with the described jig A to assure quick and accurate drilling of bone for distal bone-screw anchorage to an installed intramedullary nail 13. First an intramedullary nail 13 should be selected for nail diameter and overall length to serve the surgeon's purposes in the light of a particular fracture 11. Suitable surgery is performed to assure entry of the selected nail in direct alignment with the medullary cavity, but first it is recommended that, at least for distal-drilling purposes, the selected nail be assembled to the jig A to ascertain correct length adjustment (via dowel knob 27) at the correct one of the predrilled locations 28 along guide bar 26. Outrigger 30 should be assembled to bar 26, along with two drill guides 31, securely setting the knob of bolt 33 and of the drill-guide clam 31'. Additionally, stabilizer rod 35 should be inserted in bore 37 in guide bar 26 and the correctly selected shim fitment 40 should be assembled with its upper and lower jaws engaged in the upper and lower circumferential grooves 39, 39' of rod 35. Depression of rod 35 may or may not be necessary to bring rod 35 into contact with nail, at which point visual sighting or trocar passage down each drill-guide bore should confirm correct alignment with the respective bone-screw holes in nail 13. That done, all is in readiness for a correctly aligned drilling procedure, which of course must be preceded by correct surgical insertion of the intramedullary nail 13 in the fractured bone.

After installing nail 13, whether the nail be solid or hollow, and with the handle 23 of the jig (A) locked in its keyed connection to the proximal end of the nail, the guide bar 26 should be introduced into the handle 23, moving the same to its pre-established point for locking-screw retention via knob 27 at one of the length-selection bores 28 in guide bar 26; for convenience, the upper surface of the guide bar 26 will be understood to have been inscribed with unit-length markers at unit spacing, corresponding to the length of intramedullary nails of an available set, and it will be further understood that engraved length designations, such as 280, 300... in increments of 20-mm up to 400-mm, may be inscribed adjacent successive length markers, as the same may have been available from which to have selected nail 13. Such numerical inscriptions alongside successive length markers that are readable, as at bar-26 emergence from guidance through handle 23, enable the surgeon to make fast and correct length adjustment and locking of bar 26, in support of the distal operations to be performed.

The distal outrigger 30 is next mounted on guide bar 26 so that it is positioned on the medial side of the tibia, and the screw guides 31 are inserted into the outrigger to determine proper locations for the incisions. An incision is then made beneath each screw guide, and the medial cortex is exposed in each incision by blunt dissection, taking care to avoid entrapment of or damage to the saphenous nerve and vein. The guides 31 are then advanced until they are in contact with the medial cortex. The clamp 31' on outrigger 30 is then tightened to hold the screw guides firmly in place.

Before any bone-screw holes are drilled, the system is stabilized in exact alignment. To this end, a drill guide (not shown) is inserted into the vertical bore 37 which has been previously described for stabilizer-rod (35) accommodation; an incision is made in the skin directly beneath this vertically

oriented drill guide, and the anterior tibial cortex is exposed by blunt dissection. The drill guide is then advanced until its teeth are engaged onto the anterior border of the tibia; whereupon, a drill bit (e.g., of 4-mm diameter) is used to drill only the anterior cortex, and the drill bit is then removed. At this stage, because of the shape of the drill bit, the hole in the bone is tapered so that a square-ended 4-mm T-handled reamer (not shown) is passed down the drill guide, to complete the hole down to the nail, and intervening debris is removed. The hand reamer and vertical drill guide are now removed and are placed by entry of stabilizer rod 35 in vertical bore 37, the same being inserted to the point of reduced end (38) passage through the drilled hole in the cortex and into contact with nail 13. The stabilizing rod 35 must be set into the correct position for the particular diameter of nail 13, and this is achieved by inserting the correct U-shaped spacer (with shim thickness T) 40 over guide bar 26, so that its forks engage into the two circumferential grooves 39, 39' of the stabilizer rod. The correct shim is observable via inscription of nail diameter on the exposed upper face of shim 40, as indicated by the engraved marking "NAIL ϕ " shown on this face in fig. 6, Meaning "nail diameter 9-mm". The outrigger 30, its screw guides engaged to the bone, and its stabilizer rod 35 engaged to the nail, now have the relationship shown in Fig. 8.

An assistant to the surgeon now presses on the T-handle 36 of the stabilizer rod, thus pressing its lower end or tip into loaded contact with the nail 13. This procedural step will be seen to achieve the following:

1. The surgeon is assured that the distance between the nail and the guide bar is precisely what it was checked out to be prior to nail insertion in the medullary canal, and this fact also allows for take-up of any bending of the nail in the sagittal plane, thus maintaining and assuring alignment of the distal drill-guide (31) targeting of bone-screw holes 19 in the nail; and

2. The guide bar 26 and outrigger 30 are stabilized, so that the surgeon has a secure platform for drilling distal holes in the bone.

Those skilled in the art of setting bone screws through correctly drilled "blind" distal holes in bone should not need further instruction, but it is perhaps well to review successive steps that are recommended for drilling and distal locking, as follows:

(i) The surgeon's assistant should maintain constant gentle downward pressure on the T-handle of stabilizer rod 35, throughout the procedure which follows, as far as step (x) below.

(ii) A 4-mm drill guide is inserted into one of the guides 31, and is gently tapped to engage its distal-end teeth in the medial cortex.

(iii) A drill stop is locked to a selected 4-mm drill bit at the proximal end.

(iv) The drill bit is inserted into the drill guide, down to the bone, with the drill bit chucked to a hand-held electric drill, before the drill is started.

(v) The surgeon now drills steadily through the medial cortex, and stops the drill when the second cortex is reached.

(vi) The drill stop is moved proximally until it is 5-mm above the top of the drill guide, and is locked into place. This resetting of the stop represents an allowance for the thickness of the second cortex.

(vii) Drilling now continues through the second cortex. The drill stop prevents damage to the tissues beyond the bone, and also provides a method of estimating the correct length of locking screw.

(viii) The drill bit is removed with the drill guide.

- (ix) An angled trocar is selected and now inserted into the screw guide, so that it passes through the nail, and engages in the far cortex. The trocar has now stabilized the position of the guide bar and outrigger.
- (x) Now that the screw-guide alignment is held by the trocar, the assistant may release the pressure on the T-handle of stabilizer rod 35.
- (xi) The locking screw length, from the base of the screw head, is determined by measuring the amount of drill bit protruding from the drill guide.
- (xii) The drill stop is now replaced at the proximal end of the drill bit, in readiness for repeating the drilling procedure for the other one of the distal bone-screw holes of nail 13.
- (xiii) The second locking hole is now drilled, using exactly the same technique.
- (xiv) The length of the second locking screw is determined as before.
- (xv) A locking screw of correct length is now inserted into the second guide 31, and pushed through the bone, as with a suitably marked T-wrench, until the thread engages with the medial cortex. The locking screw is now turned clockwise, exerting gentle pressure, until a mark on the shaft of the T-wrench reaches the top of the screw guide. It is important not to continue turning after this position is reached, otherwise the thread in the bone will be stripped.
- (xvi) The trocar is removed from the first guide 31, and the same technique is followed for the insertion of the second locking screw, after which both guides 31 are removed by loosening the guide-locking knob 31'.
- (xvii) A check should now be carried out with an Image Intensifier or by x-ray to confirm that both screws have passed through the nail and to confirm that the reduction has been maintained.

(xviii) The distal outrigger 30 and the T-handled stabilizer or spacing bar 35 are now removed.

Having completed first the distal installation of bone screws, and before proximal locking, the fracture should be examined by x-radiation to determine whether there is any remaining distraction. If there is, conventional techniques are known, whereby to reduce the distraction, so that proximal locking can proceed.

For proximal-locking use of the jig A, and with the distal outrigger 30 and stabilizer rod 35 removed, it is first necessary to reset guide bar 26 in handle 23, by setting the locking knob 27 so as to engage and lock handle 23 to bar 26 via another locating bore 50 near the distal end of bar 26. This will expose the two dowel-engageable bores at the distal end of bar 26, for acceptance of the two locating dowels 51 of a proximal outrigger structure 52. In the case depicted, the two bone-screw holes 18, 18' for proximal bone-screw anchorage are on orthogonally related axes that are longitudinally spaced from each other; the proximal outrigger 51 therefore straddles guide bar 26 via its central body region, with its dowel pins 51 projecting downward from its central body region, and with provision for locking the outrigger to the guide bar by way of knob-driven means 53. Drilling access on the respective axes of these holes 18, 18' is at equal and opposite 45° inclinations with respect to the sagittal plane of nail 13, and therefore the proximal outrigger 52 provides at one of its ends for clamped mounting of a drill guide 54 in alignment with hole 18, and, at the other of its ends, for clamped mounting of a second drill guide 54' in alignment with the other proximal bone-screw hole 18'. Clamping access for setting the drill guides 54, 54' is identified at knobs 55, 55' in Figs. 9 and 10.

Procedurally, it is not necessary for the surgeon to check out his jig settings of drill guides prior to nail 13 implantation in the fractured bone, as long as the surgeon has become familiar enough to rely on proper use of correct accessories, such as the distal outrigger 30 and the proximal outrigger 52 for a given nail 13. However, before the surgeon has become that familiar with the jig and its proper use, it is well that he additionally check out the coordination of events and relationships at the proximal drilling alignments, as well as the distal drilling alignments, all prior to implantation of nail 13 in the tibia. Fig. 10 shows the relation of parts, for such checking at the proximal drilling sites, prior to nail 13 implantation. Not only does Fig. 10 show that each of the drill guides 54, 54' may be checked for accuracy of registration with the respective proximal bone-screw holes 18, 18', but Fig. 10 additionally shows use of a trocar 56 inserted in one (54) of the drill guides and into stabilizing entry of the aligned bone-screw hole 18 (not visible in Fig. 10, but shown in Fig. 2).

Use of the proximal-locking feature of the jig for proximal drilling is very much as for the case of distal drilling although there is no need for a stabilizer rod 35 or its equivalent, since proximal drilling is so close to the location of jig connection.

After locking the pin or knob 27 to the proximal reference location 50 on guide bar 26, the proximal outrigger 52 is mounted and locked to bar 26, the proximal outrigger 52 is mounted and locked to bar 26, and two screw guides 54 and 54' are clamped at 55, 55' to locate proper sites for the incisions. Two incisions are made, one antero-lateral and one antero-medial, and the tibial cortex is exposed in each case by blunt dissection. The screw guides 54, 54' are advanced down to the cortex and locked in position via clamp knobs 55, 55'. A drill guide is inserted into one of the screw guides, and tapped gently

to engage its distal teeth into the cortex. The drill bit is pushed down to the bone, and pressed against the cortex before drilling begins. Further procedures track those described for distal locking. The bone screws are inserted after each hole is drilled, and their length is determined, as described for distal insertion of bone screws.

The modification of Figs. 11 and 12 illustrates that the invention is also applicable to use of intramedullary nails for fractured femurs wherein the axes of spaced parallel bone-screw holes 60, 60' for distal-end fixation to bone extend in a first geometric plane which coincides with the sagittal plane, whether the nail is of bent or straight configuration, the point being that when the proximal end of the nail is keyed in its chucked connection to handle 23, the guide bar, here identified as 26', is parallel to the straight portion 15 of the intramedullary nail. The axes of the straight portion 15 of the nail, and of the jig guide bar 26', and of the bone-screw holes 60, 60' are thus all in the sagittal plane, marked S in Fig. 11.

Since the drilling for bone-screw alignment with nail holes 60, 60' must now also be in the sagittal plane, the distal end of guide bar 26' is seen to provide for the releasably clamped mounting of drill guides 31 for such drilled alignment. Specifically, the distal end of bar 26' is so devised that a clamp block 61 may be clamped via knob actuation at 62 to support the precise spaced parallel relation of two drill guides 31. To this end, the confronting vertical faces of block 61 and of the uncut remainder 63 of the distal end of bar 26', are formed with matching cylindrically arcuate concavities for drill-guide support, and guide pins or dowels 64 carried by block 61 will be understood to have precision location and guidance in corresponding bores (not shown) in the distal-end portion 63 of bar 26'.

An outrigger 65 is generally as described for the outrigger 30 of the first embodiment, in that it has spaced parallel guide pins 32 and a locking knob 33 for accurate and secure outrigger mounting to the upper surface of guide bar 26'. However, the laterally and downwardly offset other end of the outrigger is devised for guidance and selective positioning of a spacer or stabilizer rod 35 in alignment with the central axis of the distal nail portion 15 and extending in a second geometric plane of symmetry which is perpendicular to the sagittal plane. For the purpose, the same spacer rod 35 with its spaced grooves 39, 39' is again used for guidance in a bore 37' in the offset end of the outrigger, and a U-shaped shim fitment 40 is selected for assurance that when rod 35 is pressed into mechanical contact with nail 13, it can be known for sure that drill guides 31 are precisely aligned with the bone-screw holes 60, 60' of the nail.

In use of the embodiment of Figs. 11 and 12, the same procedures outlined above for distal-end use of the device of Fig. 2, will be seen to be equally applicable, except for the fact that spacer bar (35) and drill-guide (31) orientations are reversed in their respective references to the sagittal plane S.

The embodiment of Figs. 13 to 15 is in many respects similar to that of Figs. 11 and 12, except that the embodiment of Figs. 13 to 15 is of specific utility in the blind-hole drilling of a fractured femur, wherein the intramedullary nail 113 is straight, with distal transverse bone-screw holes 160, 160' which are on parallel axes that are perpendicular to the central axis of nail 113 and thus determine the first geometric plane of symmetry. The handle A' has selectively locked and keyed connection to the proximal end of nail 11; handle A' extends perpendicular to nail 113 within the first plane of symmetry, and handle A' is also perpendicular to elongate guide-bar structure 126, with means 127 whereby to selectively clamp structure 126 (i) in the indicated

plane of symmetry and parallel to nail 113, and (ii) with such distally offsetting projection of structure 126 as to position its two drill guides 131/131', in potential (if not actual) aligning registration with the bone-screw holes 160, 160' of nail 113. Set screws on inclined axes 140/140', and accessible via the upper surface of jig bar 126, will be understood to provide adjusted axial positioning of drill guides 130/130', respectively.

The distal end of bar structure 126 is shown carrying the upper end of outrigger structure 165 which has a vertical-plane mounting face that is in clamped abutment with one of the vertical faces of the constant cross-section of guide-bar structure 126, being clamped by knob-headed bolts 132 which seat against the opposite vertical face of structure 126. It will be understood that bolts 132 have smooth cylindrical dowel-like fit to transverse bores in bar structure 126 and that only their threaded distal ends engage threaded bores in the confronting upper end of the outrigger structure 165. The lower (and laterally offset) end of outrigger structure 165 has a guide bore on an axis perpendicular to the axis of nail 113 and also extending in the second geometric plane of symmetry which is perpendicular to the indicated first geometric plane of symmetry, being shown to mount a guide sleeve 135' for slidable guidance of stabilizing rod 135. Rod 135 has a manipulating handle 136 at its proximal end, and a reduced distal end 138 for stabilizing contact with nail 113.

Finally, as best seen in Figs. 14 and 15, a spacer element 100 has a body with three pairs of upstanding feet 101/101', 102/102', and 103/103', which enable precise positioning of the distal end 138 of rod 135, specific to the outer radius of the nail 113 it is to abut. The first and second pairs of feet 101/101' and 102/102' will be understood to be spaced at distance T_1 for accurate friction fit to the opposing parallel faces of outrigger 165, at guide-sleeve

(135') passage therethrough. The third pair (103/103') of upstanding feet are at reduced spacing T_2 from each other, wherein T_2 is less than the diameter of stabilizing rod 135 thus enabling entry of feet 103/103' into an axially locating circumferential groove 139 in rod 135; the thickness T_3 of feet 103/103' has sufficient match to the axial extent of groove 139 to permit a sliding precision fit to groove 139 and to provide a well located positioning of groove 139 with respect to the lower or distal end of the outrigger structure 165.

It will be seen that legs 103/103' have a fixed offset from the two pairs 101/101', 102/102' which engage the distal end of the outrigger; in Fig. 15, the dimension X will be understood to designate this fixed offset. It will further be understood that the dimension X, although fixed, is nevertheless specifically related to the radius R of the intramedullary nail 113 with which stabilizer rod 135 and spacer element 100 are to be used, for a guarantee of drill-guide (131) alignments with holes 160/160' when nail 113 is abutted by the distal end 138 of rod 135. Thus, as in the case of spacer 40 of Fig. 11, the spacer 100 of Figs. 13 to 15 is unique to a particular nail diameter (2R), and permanent indicia of the particular nail diameter are preferably inscribed on each spacer 100 of a plurality to serve a range of nail diameters.

Assembly of the stabilizer system of Figs. 14 and 15 first involves insertion of the guide sleeve 135' in the precision bore of the distal end of the outrigger; a set screw 104 enables releasable retention of this assembly. Next, stabilizer rod 135 is inserted into guide sleeve 135'. Finally, the spacer element 100 is applied to the distal end of the outrigger, the stabilizer rod 135 being manipulated as necessary to assure locating engagement of feet 103/103' in groove 139. Spring detents 105 (in leg 101') and 106 (in leg 103') respectively

engage guide sleeve 135' and the bottom of groove 139 to releasably retain spacer-100 assembly to the outrigger.

In Fig. 13, the clamp bolts 132 are shown on spaced axes that symmetrically straddle the vertical axis of the drill guide 131', thus assuring that the reduced end 138 of the stabilizer rod will contact nail 113 in the geometric plane which is defined by the axis of nail hole 160' and the stabilizer-rod axis. This is a geometric plane of symmetry dividing the entire outrigger structure, perpendicular to the plane of symmetry defined by jig bar 126, nail 113 and the nail holes 160/160'. It will be understood that by thus providing the means to establish accurate drilling of bone on the axis of hole 160', the accurate drilling of bone on the axis of hole 160 is achievable without further set-up or manipulation, in view of the relatively close proximity of axes of holes 160/160' to each other. And it will be further understood that simple unthreading removal of bolts 132 will release the entire outrigger/stabilizer assembly for reversible application with respect to the opposite side of the geometric plane of jig bar 126 and the nail-hole axes to be accessed by drilling via drill guides 131/131'.

CLAIMS

1. A drill jig for mechanically aligning a drill guide with one or more transverse bone-screw holes of an intramedullary nail that is installed in an elongate fractured bone, such as a femur or tibia, wherein the intramedullary nail has at least a straight distally extending portion, a proximal end adapted for jig attachment and one or more bone-screw holes in said straight distally extending portion, said one or more holes and the axis of the nail defining a first geometric plane of symmetry, said jig comprising:

- an elongate straight guide bar;
- rigid handle having means for keyed selective connection to the proximal end of the nail so that said handle extends transversely of the nail and means for guiding and retaining said guide bar parallel to the nail;
- one or more drill-guide bores in general alignment with said one or more bone screw holes;

characterized in that it comprises an outrigger structure removably carried by said guide bar and extending laterally outwardly of said first geometric plane, said outrigger structure having an end with a guide bore in a second geometric plane which includes the axis of said nail and is perpendicular to said first geometric plane, and a spacer rod adapted for mounting to the guide bore of said outrigger structure with such effective projecting length therefrom to contact said nail when the one or more drill-guide bores of said guide bar are truly aligned with the one or more holes of said nail.

2. Drill jig as claimed in claim 1, in which said handle and said guide bar extend in said first geometric plane of symmetry for aligning a drill guide with one or more transverse bone-screw holes of an intramedullary nail installed in a fractured femur.

3. Drill jig as claimed in claim 1, in which said handle and said guide bar extend in said second geometric plane of symmetry for aligning a drill guide with one or more transverse bone-screw holes of an intramedullary nail installed in a fractured tibia.
4. Drill jig as claimed in claim 1, in which the nail is of circular cross section and has a known radius, and in which the mounting of said spacer rod to said guide bar includes means for determining the effective projecting length of said spacer rod in accordance with the radius of the nail.
5. Drill jig as claimed in claims 2 and 4, in which said means for determining the effective projecting length of the spacer rod includes a shoulder formed on said rod and a spacer selectively engageable to said outrigger structure and to said shoulder at predetermined offset therefrom, said spacer being one of a plurality of spacers providing different offset that are related to different section radii of available nails.
6. Drill jig as claimed in claim 5, in which said spacer comprising a body having first means for removable engagement with and locating reference to said outrigger structure, said body extending in offset to said first removable engagement means with and reference to said shoulder.
7. Drill jig as claimed in claim 6, in which said spacer and said first and second removable engagement means are integral formations with said body.
8. Drill jig as claimed in claim 6, in which said shoulder is part of a circumferentially continuous groove adapted for engagement with said second removable engagement means.

9. Drill jig as claimed in claims 3 and 4, in which said means for determining the effective projecting length of the spacer rod includes a guide bore for inserted orientation of said spacer rod in said second geometric plane of symmetry, said rod having a shoulder for limiting the extent of rod projection toward the nail, and a shim selectively applicable to the guide bar and engageable by said shoulder, said shim being one of a plurality of shims of different thickness that is related to different section radii of available nails.
10. Drill jig as claimed in claim 1, in which said guide bar is of constant non-circular section and has two longitudinally spaced parallel guide pin bores.
11. Drill jig as claimed in claim 10, in which said outrigger structure has two fixed parallel guide pins for assembled orientation of said outrigger structure to the guide bar by means of said guide pin bores.
12. Drill jig as claimed in claim 1, in which said guide bar is adjustably securable to said handle at predetermined longitudinal locations coordinated with intramedullary nail dimensions, such that upon selection of the correct location for a particularly nail-length dimension, the mounting of the outrigger structure to the glide bar ensure a correct longitudinal position of the one or more drill-guide bores in alignment with the one or more bone-screw holes of the intramedullary nail.
13. Drill jig as claimed in claim 1, in which said outrigger structure includes releasable means for securing the same to said guide bar so that said outrigger structure can be selectively and reversibly secured to said guide bar on either side of the geometric plane of symmetry including the axis of the nail.

14. Drill jig as claimed in claim 3, in which the outrigger structure extends to a single lateral and downward offset with respect to the guide bar and with respect to said first geometric plane of symmetry such that the drill-guide bores of said outrigger structure are perpendicular to said first geometric plane.

15. Drill jig as claimed in claim 1, in which said nail has a circular section having known radius, and in which said guide bar has a guide bore for inserted orientation of said spacer rod in said second geometric plane of symmetry, said spacer rod having two spaced circumferential grooves, a U-shaped fitting adapted to fit the one side of the guide bar, the opposite legs of the U-shaped fitting lapping upper and lower limits of the cross section of the guide bar, said legs being slotted to define spaced fork elements which are engageable with the spaced grooves of the spacer rod whereby to limit the spacer-rod approach to the intramedullary nail.

16. Drill jig as claimed in claim 15, in which the thickness of one of said legs of the U-shaped fitting being of predetermined relation to the known radius of the intramedullary nail such that, when the spacer rod is urged axially thereof for contact engagement with the intramedullary nail, the contact will be such as to determine correct alignment of the one or more drill-guide bores with the one or more bone-screw holes of the intramedullary nail.

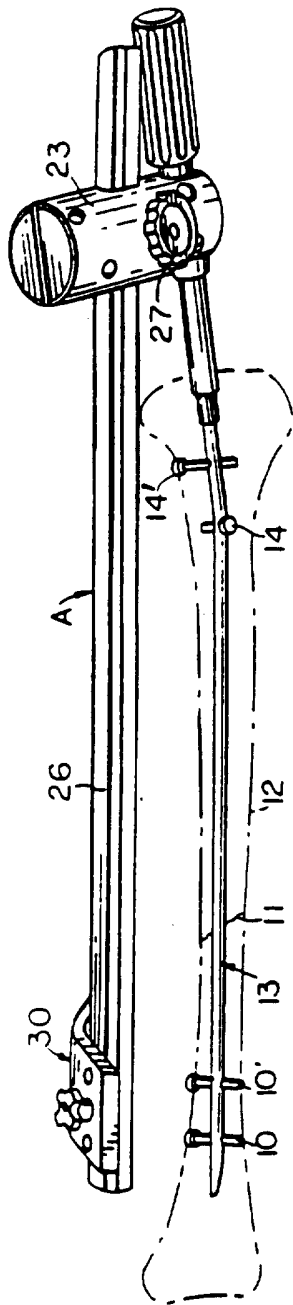

FIG. 1

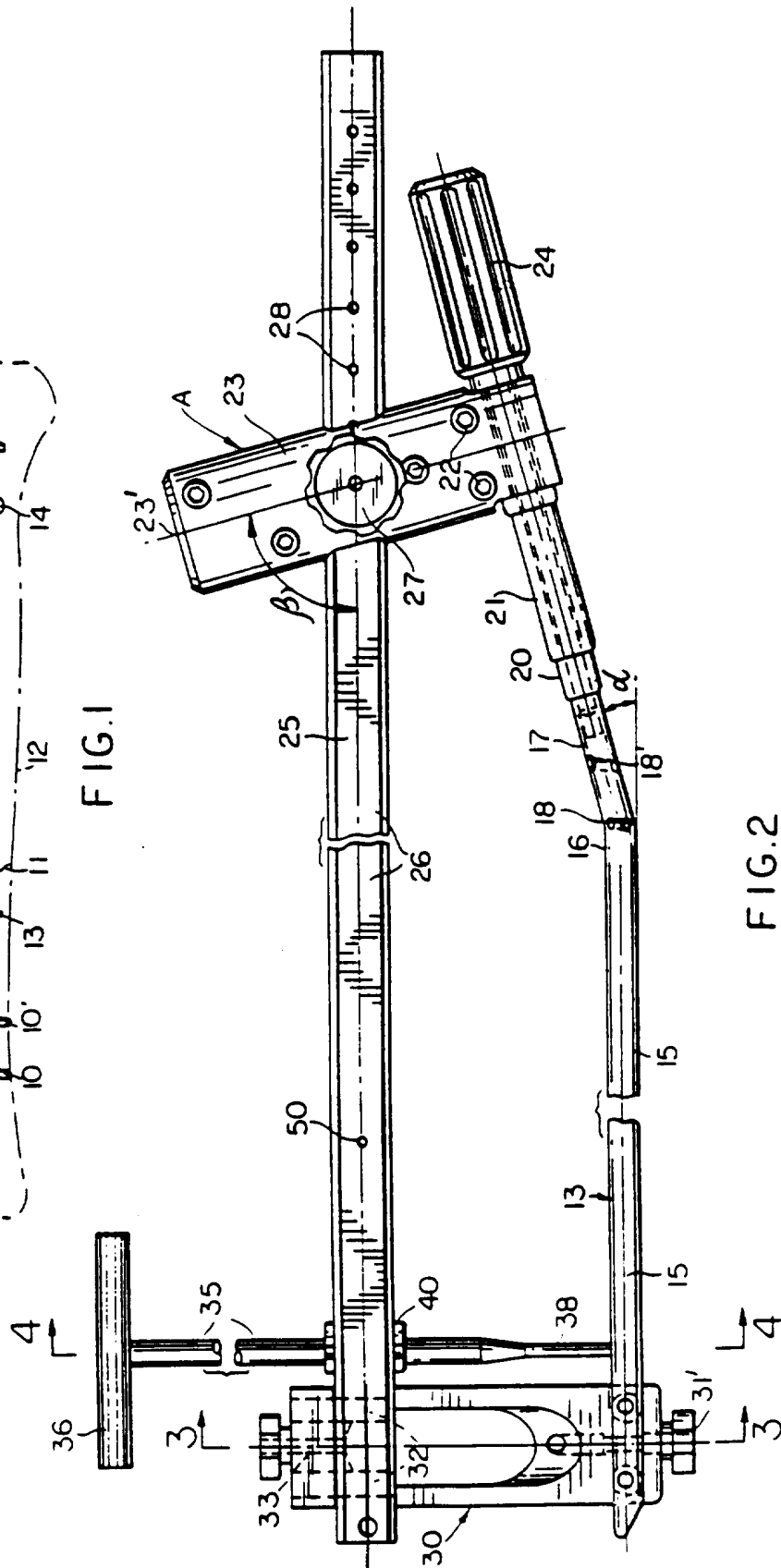

FIG. 2

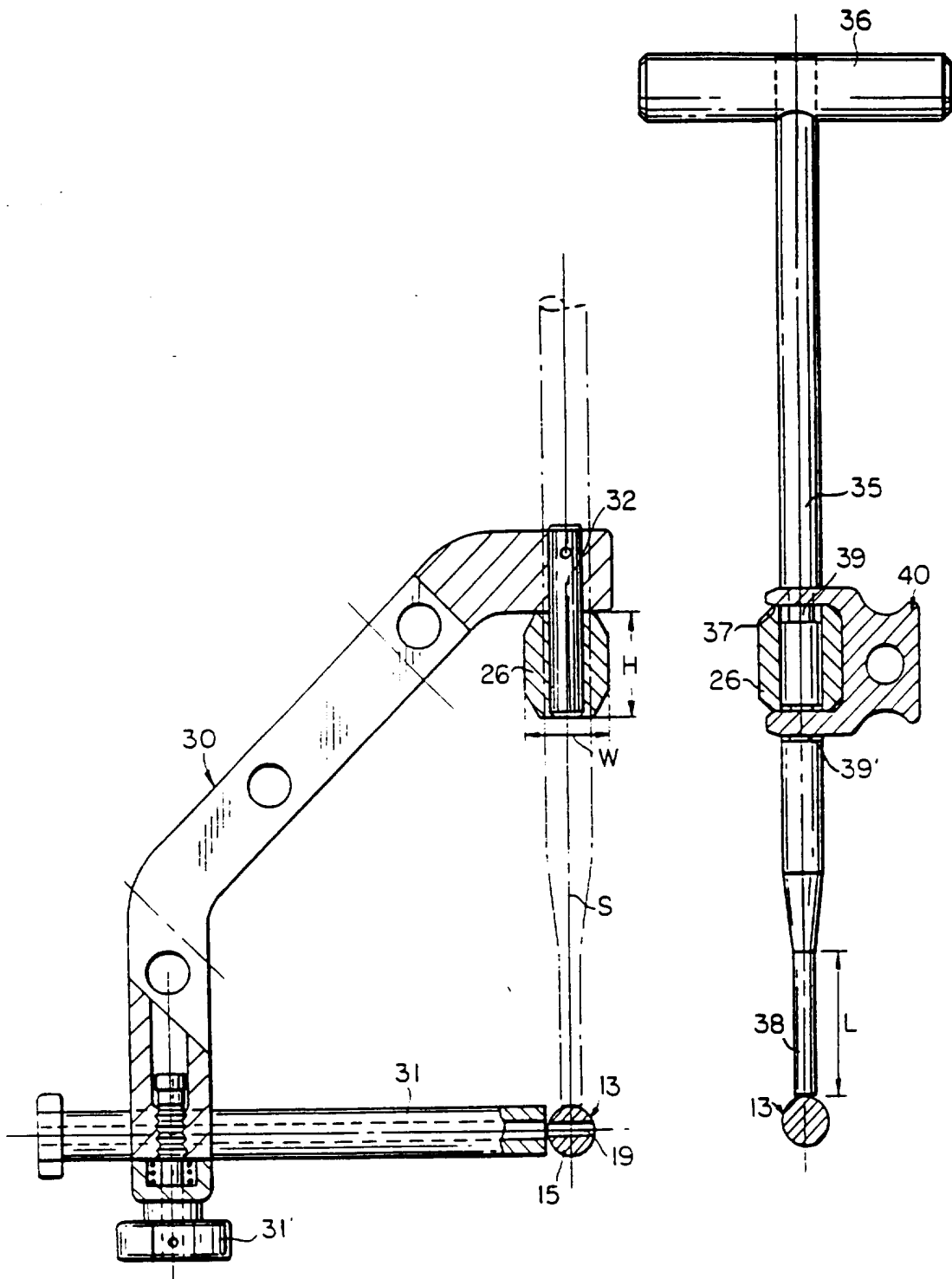

FIG.3

FIG.4

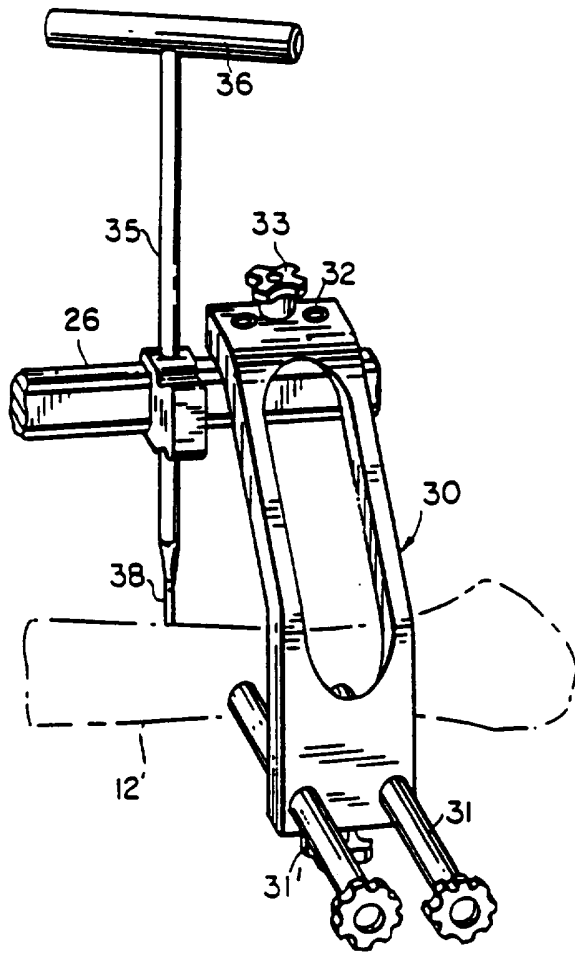

FIG. 8

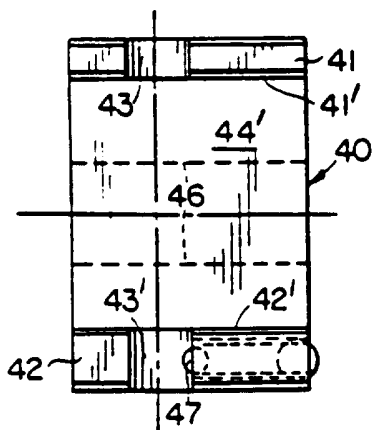
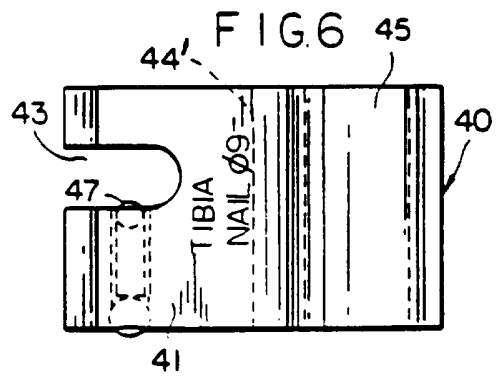

FIG. 7

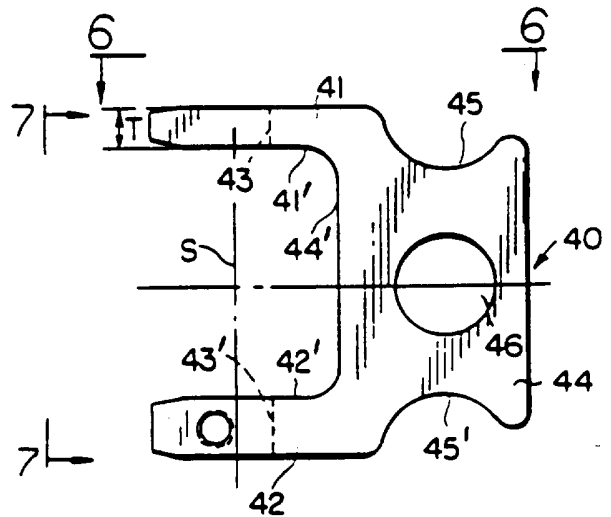

FIG. 5

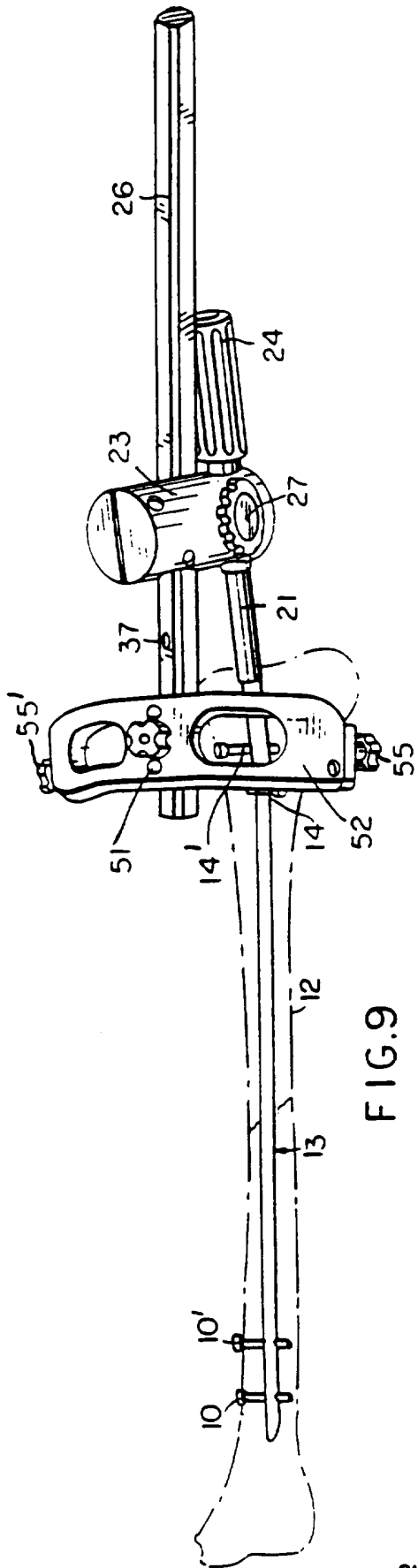

FIG. 9

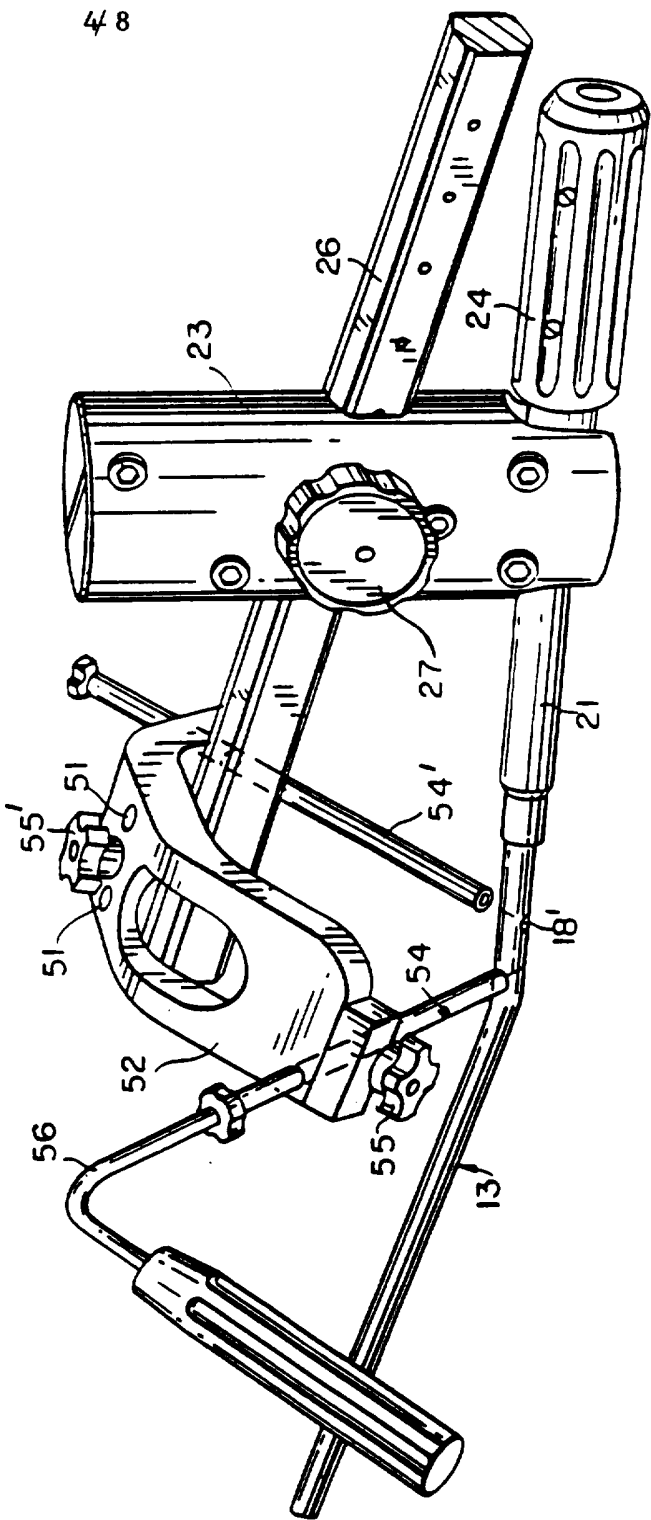

FIG. 10

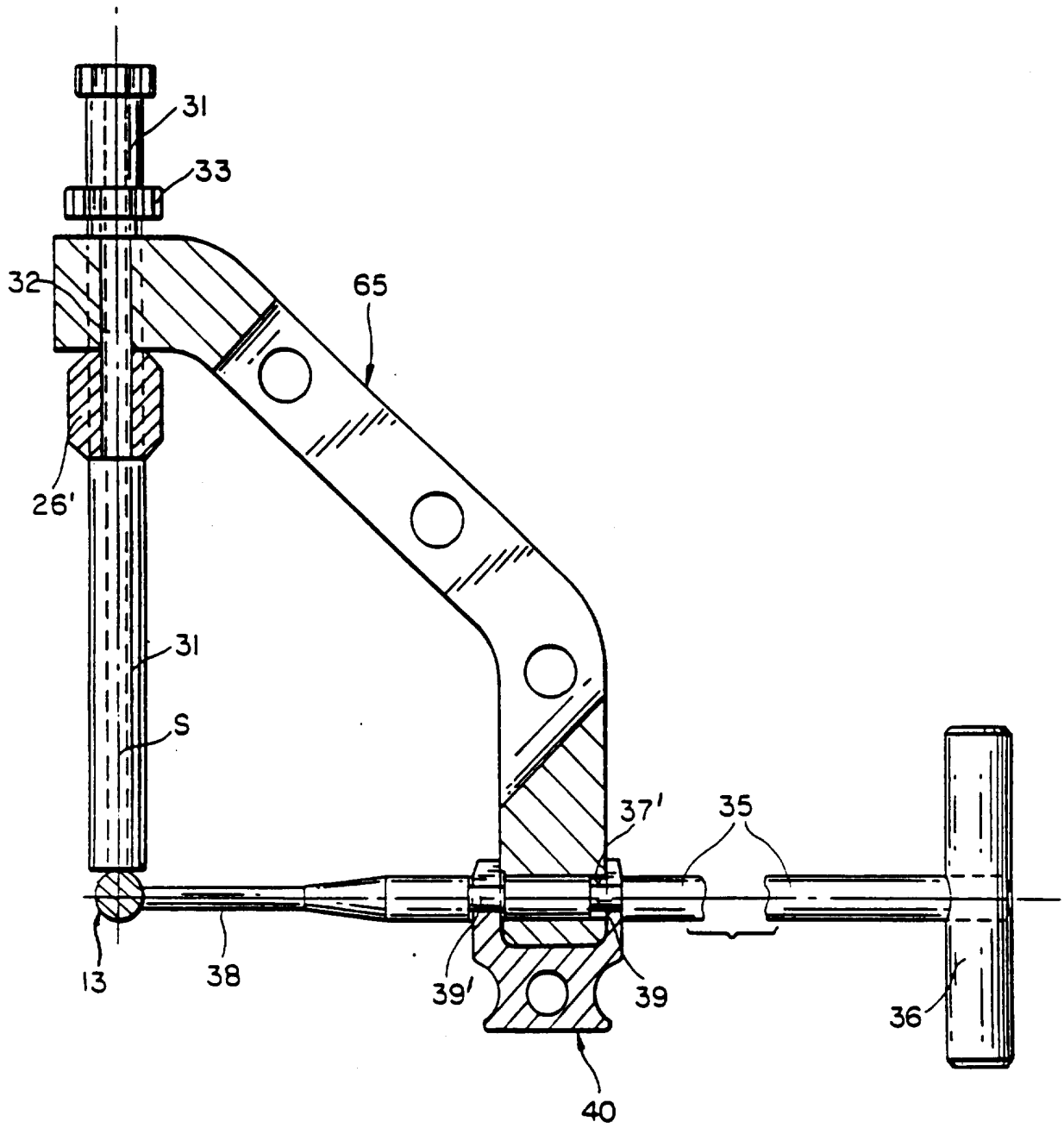

FIG. II

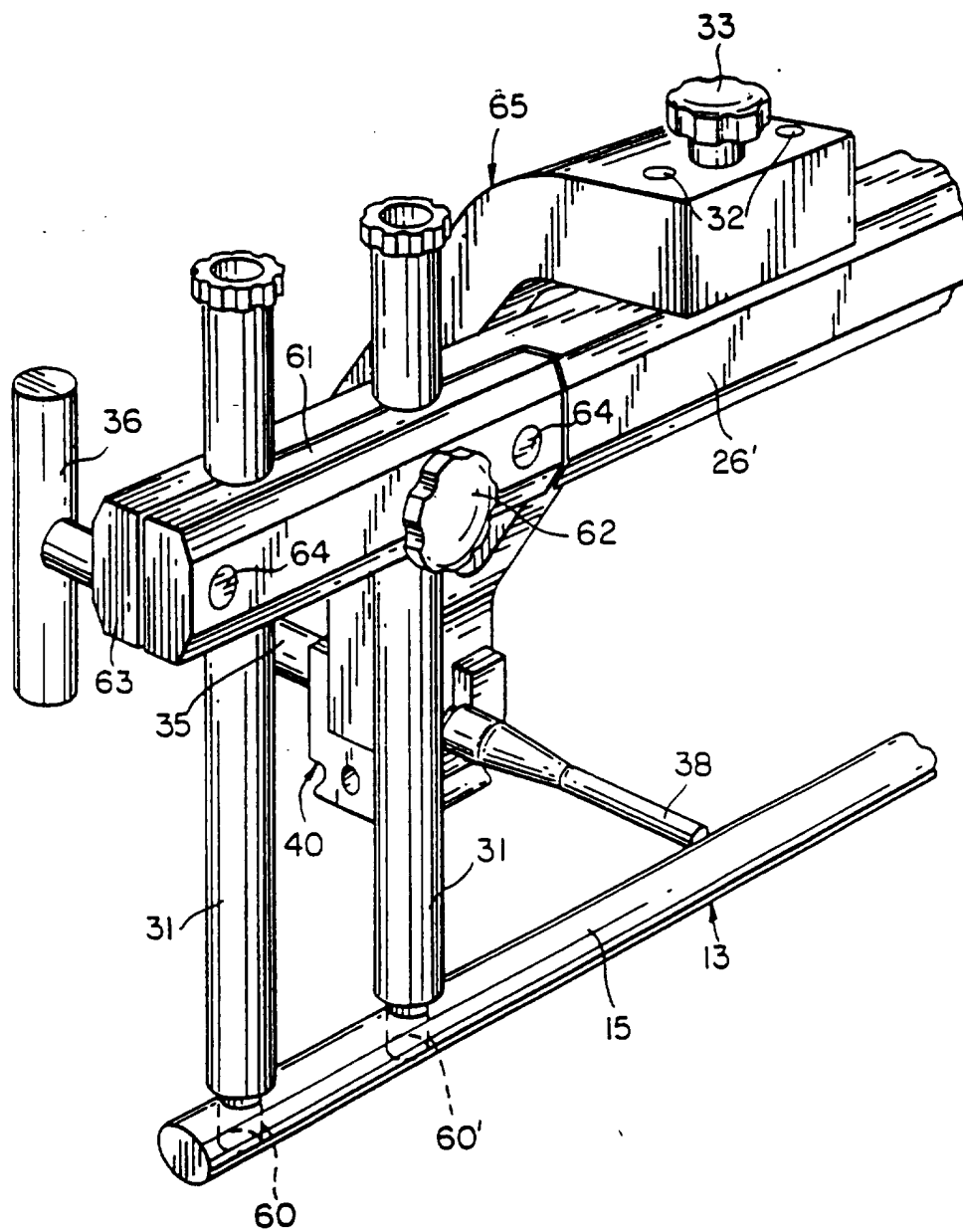

FIG. 12

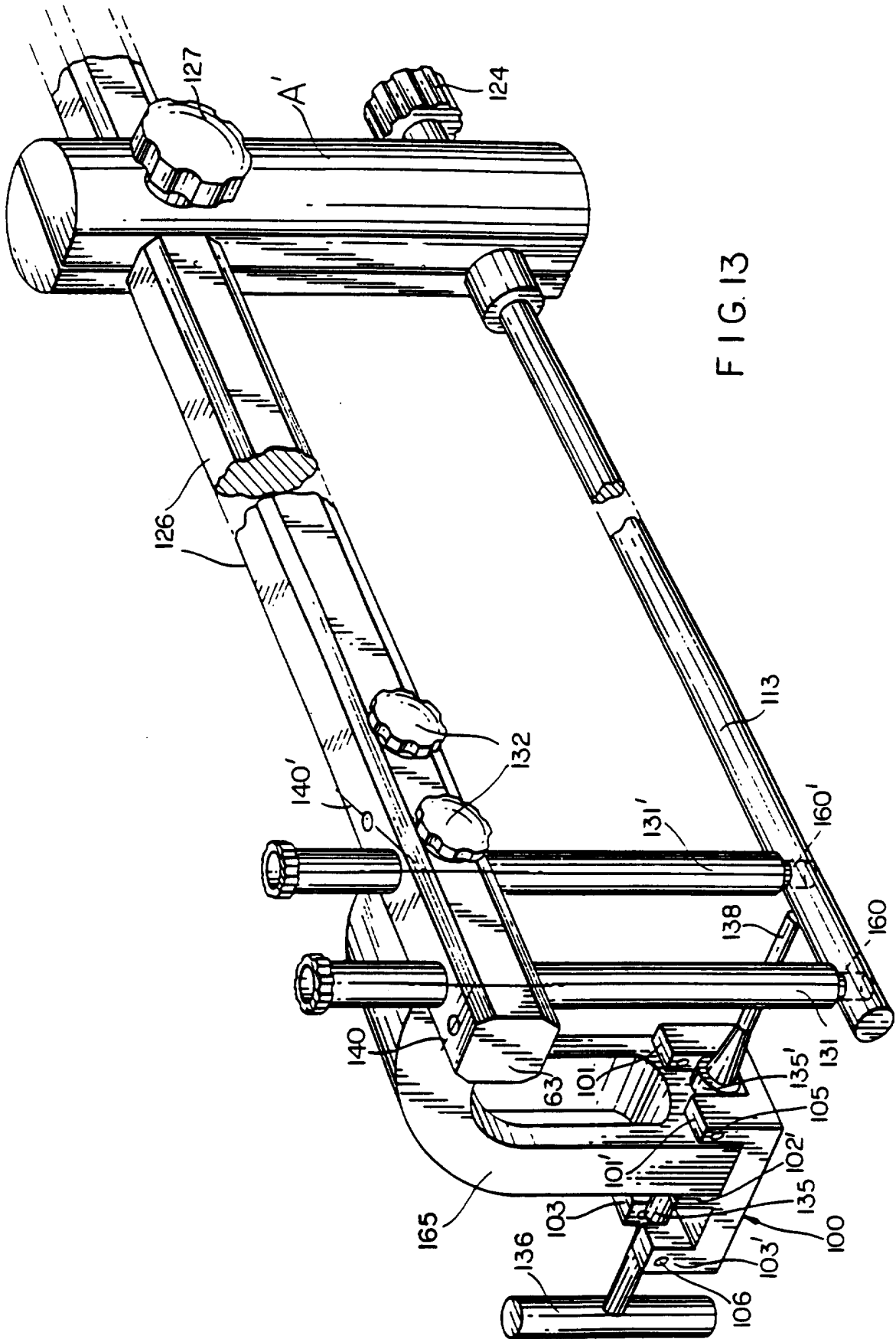

FIG. 13

INTERNATIONAL SEARCH REPORT

 International Application No
 PCT/IB 95/00552

 A. CLASSIFICATION OF SUBJECT MATTER
 IPC 6 A61B17/17

According to International Patent Classification (IPC) or to both national classification and IPC

B. FIELDS SEARCHED

 Minimum documentation searched (classification system followed by classification symbols)
 IPC 6 A61B

Documentation searched other than minimum documentation to the extent that such documents are included in the fields searched

Electronic data base consulted during the international search (name of data base and, where practical, search terms used)

C. DOCUMENTS CONSIDERED TO BE RELEVANT

Category *	Citation of document, with indication, where appropriate, of the relevant passages	Relevant to claim No.
A	GB,A,2 258 154 (ORTHOFIX SRL) 3 February 1993 see the whole document ---	1
A	US,A,4 667 664 (TAYLOR ET AL.) 26 May 1987 see column 7, line 1-17; figures ---	1
A	FR,A,2 647 006 (ZIMMER S.A.) 23 November 1990 see figures ---	1
A	DE,A,42 40 277 (PENNIG) 9 June 1993 see abstract; figures -----	1

 Further documents are listed in the continuation of box C.

 Patent family members are listed in annex.

* Special categories of cited documents:

- *A* document defining the general state of the art which is not considered to be of particular relevance
- *E* earlier document but published on or after the international filing date
- *L* document which may throw doubts on priority claim(s) or which is cited to establish the publication date of another citation or other special reason (as specified)
- *O* document referring to an oral disclosure, use, exhibition or other means
- *P* document published prior to the international filing date but later than the priority date claimed

- *T* later document published after the international filing date or priority date and not in conflict with the application but cited to understand the principle or theory underlying the invention
- *X* document of particular relevance; the claimed invention cannot be considered novel or cannot be considered to involve an inventive step when the document is taken alone
- *Y* document of particular relevance; the claimed invention cannot be considered to involve an inventive step when the document is combined with one or more other such documents, such combination being obvious to a person skilled in the art.
- *&* document member of the same patent family

Date of the actual completion of the international search

6 November 1995

Date of mailing of the international search report

17. 11. 95

Name and mailing address of the ISA

 European Patent Office, P.B. 5818 Patentlaan 2
 NL - 2280 HV Rijswijk
 Tel. (+ 31-70) 340-2040, Tx. 31 651 epo nl,
 Fax (+ 31-70) 340-3016

Authorized officer

Giménez Burgos, R

INTERNATIONAL SEARCH REPORT

information on patent family members

International Application No

PCT/IB 95/00552

Patent document cited in search report	Publication date	Patent family member(s)	Publication date
GB-A-2258154	03-02-93	IT-B- 1253255 DE-A- 4136308 FR-A- 2679764	14-07-95 04-02-93 05-02-93
-----	-----	-----	-----
US-A-4667664	26-05-87	NONE	
-----	-----	-----	-----
FR-A-2647006	23-11-90	NONE	
-----	-----	-----	-----
DE-A-4240277	09-06-93	DE-U- 9114985	27-02-92
-----	-----	-----	-----