

No. 768,863.

PATENTED AUG. 30, 1904.

A. NEUBERT.  
HANGER FOR TROLLEY WIRES.  
APPLICATION FILED DEC. 10, 1903.

NO MODEL.

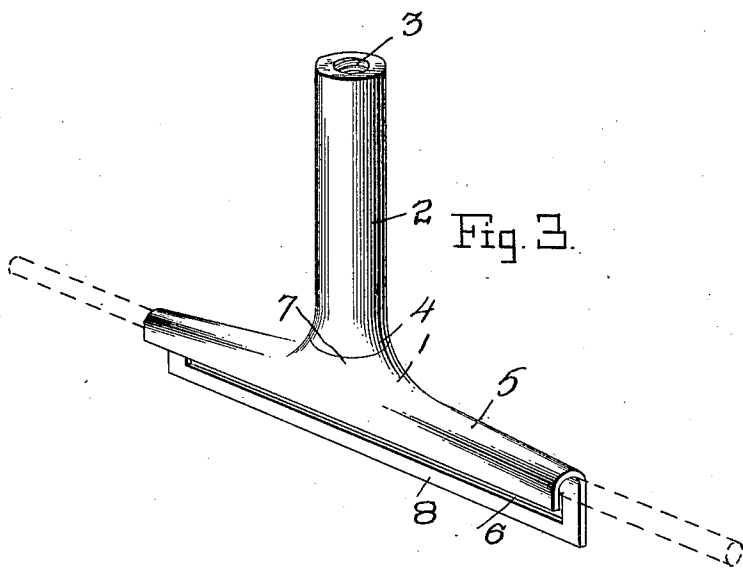
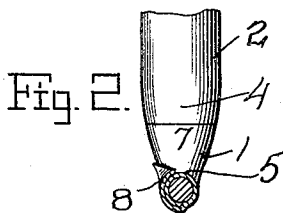
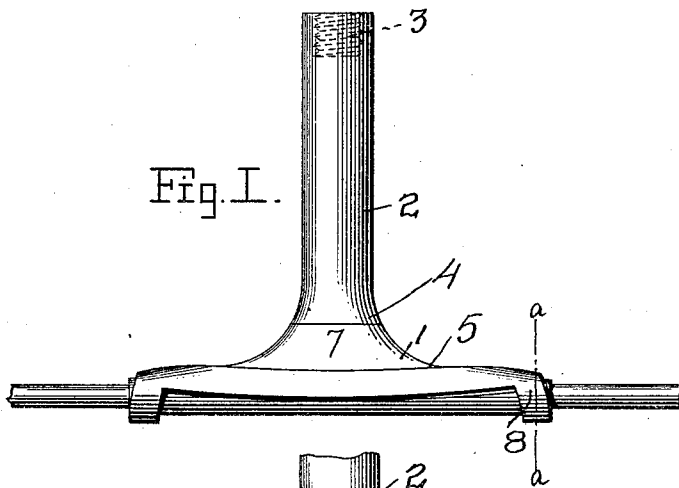

Inventor

Augustus Neubert.

Witnesses

E. K. Reichenbach.

*E. Wilson*

By

*A. B. Wilson*

Attorney

# UNITED STATES PATENT OFFICE.

AUGUSTUS NEUBERT, OF ELIZABETH, NEW JERSEY.

## HANGER FOR TROLLEY-WIRES.

SPECIFICATION forming part of Letters Patent No. 768,863, dated August 30, 1904.

Application filed December 10, 1903. Serial No. 184,641. (No model.)

*To all whom it may concern:*

Be it known that I, AUGUSTUS NEUBERT, a citizen of the United States, residing at Elizabeth, in the county of Union and State of New Jersey, have invented certain new and useful Improvements in Hangers for Trolley-Wires; and I do declare the following to be a full, clear, and exact description of the invention, such as will enable others skilled in the art to which it appertains to make and use the same.

My invention is an improved hanger for overhead-trolley wires used by electric railroads and adapted for use in connection with my switch-arch described and claimed in my application for Letters Patent of the United States filed November 18, 1903, Serial No. 181,734, and also adapted for use in other connections; and it consists in the construction and combination of devices hereinafter described and claimed.

The object of my invention is to provide an improved device of this character which is provided with means for clenching the trolley-wire and securing the same thereto and so securely as to prevent the possibility of the wire being released and enabled to drop therefrom.

In the accompanying drawings, Figure 1 is a side elevation of a hanger embodying my improvements, showing the same attached to a trolley-wire. Fig. 2 is a transverse sectional view of the same, taken on the plane indicated by the line *a a* of Fig. 1; and Fig. 3 is a detail perspective view showing the hanger prior to the attachment of the trolley-wire thereto.

My improved hanger comprises a clencher-head 1 and a suspending element 2, which is here shown as of cylindrical form, provided at its upper end with a screw-socket 3 to enable a disconnecter to be screwed to the said suspending element. The latter is preferably made of iron, and its lower end is enlarged, as at 4. The clencher-head 1 is preferably made of copper, but may be made of any other suitable conducting metal, and its main portion 5 is of substantially semitubular form open on its under side, as at 6. At the center of the clencher-head the same is formed with a boss or swelled portion 7, which in practice is united to the enlarged lower end of the

suspending element 2 by braces. Within the scope of my invention the clencher-head may be secured to the suspending element by any suitable means, and I do not desire to limit myself in this particular. Formed integrally with one side of the clencher-head are clip elements 8, which extend therefrom. The same may be formed separately from the clencher-head and attached thereto by any suitable means. I do not desire to limit myself in this particular.

In order to attach the hanger to a trolley-wire, the latter is placed between the depending sides of the semitubular clenched head, and the sides of the latter are wrapped together around the wire, so as to secure the latter between the said sides. The clips 8 are then bent around and over to the top of the clencher-head and may be fastened thereto by any suitable means or may be soldered thereto. It will be understood from an inspection of the drawings, particularly of Fig. 2, that when the hanger is thus attached to the trolley-wire the sides of the clencher-head entirely surround the wire to secure the latter between them, and the clips, which are bent around and under the clencher-head and to the upper portion of the latter, are then secured thereto, extend transversely across and under the joint between the contiguous ends or edges of the sides of the clencher-head, and lock the latter, so that it is rendered impossible for it to open and casually release and drop the wire.

My improved hanger may be used in connection with the switch-arch described in my copending application for Letters Patent, hereinbefore mentioned, or it may be used for supporting the trolley-wire at other points, at will.

The clencher-head of the hanger is of such length that when the hanger is employed in a cross-town or switch arch, such as described and claimed in my copending applications for Letters Patent in the United States, Serial Nos. 184,642, filed December 10, 1903, and 181,734, filed November 18, 1903, in which the trolley-wires have their ends separated to some extent, the clencher-heads prevent the ends of the spaced wires from bending.

Having thus described my invention, what

I claim, and desire to secure by Letters Patent, is—

1. A hanger for trolley-wires having a clencher-head provided with elements adapted to be bent around a trolley-wire to secure the latter to the clencher-head, and further provided with clip devices to be bent around the clencher-head and secured thereto to prevent the latter from opening and releasing the wire.

2. A hanger of the class described, having a clencher-head adapted to be bent around a wire to secure the same thereto, and means to lock the clencher-head to prevent the same from opening and releasing the wire.

3. A hanger of the class described having a substantially semitubular clencher-head adapted to be bent around a wire, and means to lock the clencher-head when thus bent and prevent it from opening and releasing the wire.

In testimony whereof I have hereunto set my hand in presence of two subscribing witnesses.

AUGUSTUS NEUBERT.

Witnesses:

FREDERICK WEIGEL,  
K. P. WERNER.