

Sept. 16, 1924.

1,508,939

M. O. REEVES

GRINDING WHEEL DRESSER

Original Filed July 30, 1920 2 Sheets-Sheet 1

Fig. 1.

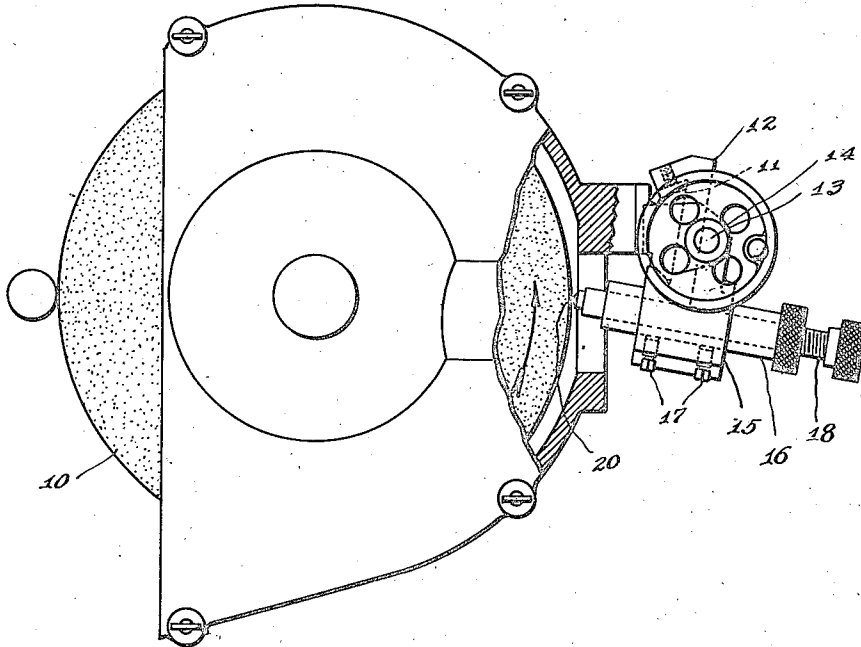
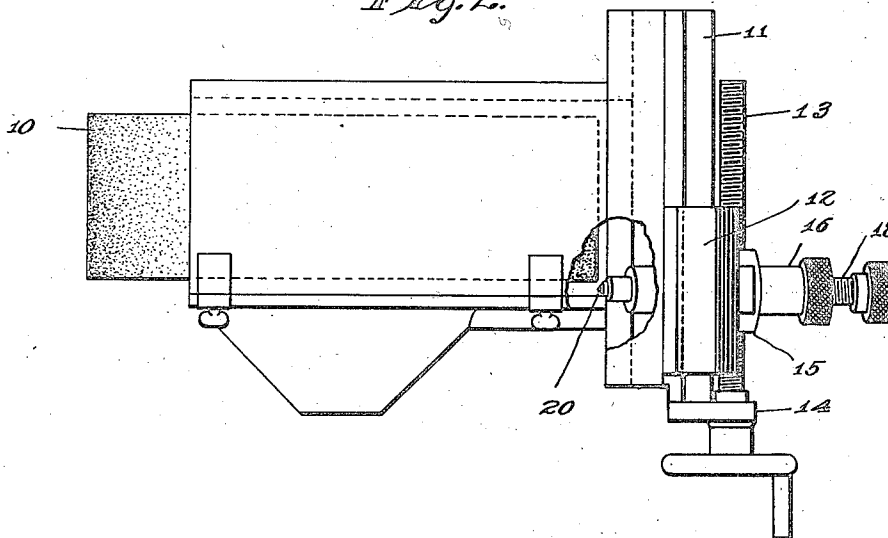

Fig. 2.



Inventor  
Milton O. Reeves,

334 Hood & Schley

Attorneys

Sept. 16, 1924.

1,508,939

M. O. REEVES

GRINDING WHEEL DRESSER

Original Filed July 30, 1920 2 Sheets-Sheet 2

Fig. 3.

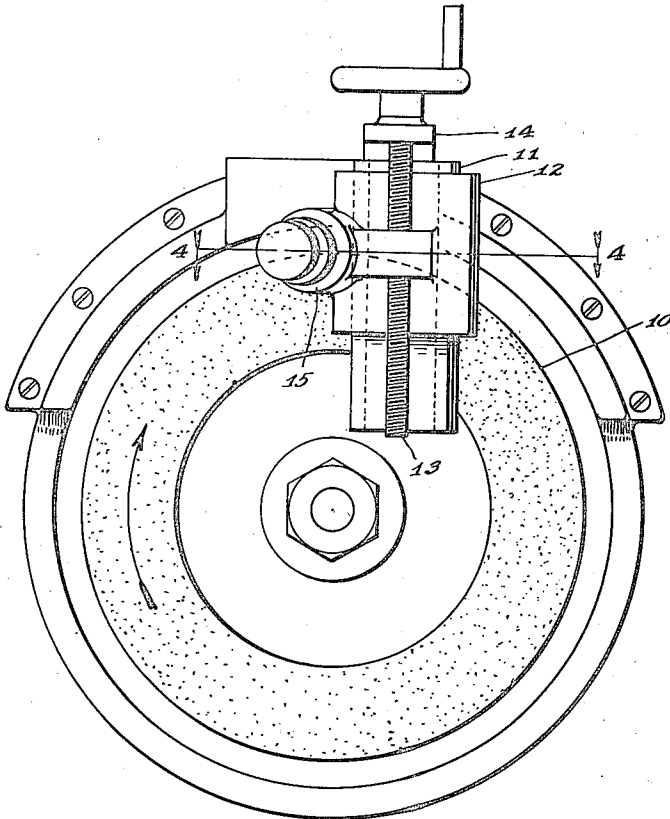
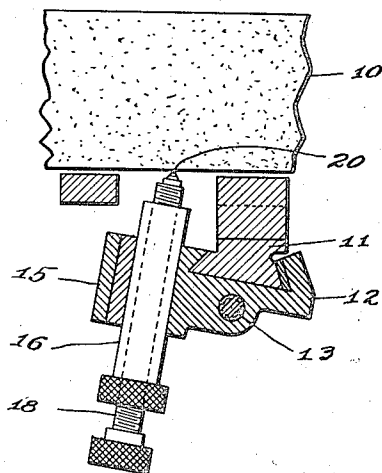

Fig. 4.



Inventor  
Milton O. Reeves,

By

Hood & Selley

Attorneys

Patented Sept. 16, 1924.

# UNITED STATES PATENT OFFICE.

MILTON O. REEVES, OF COLUMBUS, INDIANA, ASSIGNOR, BY MESNE ASSIGNMENTS,  
TO THE HEIM GRINDER COMPANY, OF DANBURY, CONNECTICUT, A CORPORATION  
OF CONNECTICUT.

## GRINDING-WHEEL DRESSER.

Application filed July 30, 1920, Serial No. 400,125. Renewed August 16, 1924.

*To all whom it may concern:*

Be it known that I, MILTON O. REEVES, a citizen of the United States, residing at Columbus, in the county of Bartholomew and State of Indiana, have invented a new and useful Grinding-Wheel Dresser, of which the following is a specification.

The object of my invention is to provide means by which grinding wheels may be accurately dressed for precision in grinding.

The accompanying drawings illustrate my invention. Fig. 1 is a side elevation of a grinding wheel having a circumferential active face and equipped with my improved dressing device; Fig. 2 is a plan of the parts shown in Fig. 1; Fig. 3 is a front elevation of my improved dressing device, arranged in conjunction with a controller wheel having an active annular crown face; and Fig. 4 is a fragmentary section on line 4-4 of Fig. 3.

In Figs. 1 and 2 of the drawings, 10 indicates a grinding wheel, 11 a guide way arranged parallel with the active face of the grinding wheel 10, a dressing tool carriage 12 mounted on the guideway and longitudinally shiftable thereon by means of a shifting screw 13, journaled in a bracket 14 on the guideway 11. Carriage 12 is provided with a sleeve 15, the axis of which is set at an acute angle to the surface to be dressed, this acute angle varying not greatly from a right angle toward the surface to be dressed, as clearly indicated in Fig. 1. Longitudinally adjustable through sleeve 15, preferably in a non-rotative mounting, is a sleeve 16 which may be held in any desired axial position by screws 17. Threaded into sleeve 16 is the shank 18 of a dressing tool holder 19 which is provided with a

dressing point 20, most conveniently a diamond.

By this arrangement, it will be noted that the dressing tool 20 may be adjusted toward and from the desired working position by an axial adjustment of the sleeve 16 and may be further adjusted toward and from an article to be dressed by a simultaneous rotative and axial adjustment of the shank 18, so that, when the dressing tool 20 has become worn to any material extent, a slight turn of the shank 18 will not only adjust the tool forwardly, but will also turn the tool slightly so as to present a sharp fresh cutting edge.

In Fig. 3, the corresponding parts are correspondingly designated. It will be noticed that here, assuming the axis of the crown wheel to be in a horizontal plane, the axis of sleeve 16 is also in a horizontal plane, but that it is swung from a vertical plane so as to form an acute angle with the surface which is to be dressed.

I claim as my invention:

A grinding wheel dresser comprising a guideway associated with the grinding wheel, a carriage movably mounted on said guideway, a sleeve mounted in said carriage at an acute angle to the surface to be dressed and capable of independent rotative and axial movement, means for holding said sleeve in adjusted position, and a dressing tool holder threaded in said sleeve.

In witness whereof, I have hereunto set my hand at Indianapolis, Indiana, this 28th day of July, A. D. one thousand nine hundred and twenty.

MILTON O. REEVES.