



US 20050194030A1

(19) **United States**

(12) **Patent Application Publication**
Goldwitz

(10) **Pub. No.: US 2005/0194030 A1**

(43) **Pub. Date: Sep. 8, 2005**

(54) **SHELTER HAVING AN EXTENDABLE ROOF**

Publication Classification

(75) Inventor: **Brian L. Goldwitz**, Orange, CT (US)

Correspondence Address:
EDWARDS & ANGELL, LLP
P.O. BOX 55874
BOSTON, MA 02205 (US)

(51) **Int. Cl.⁷** E04H 15/34
(52) **U.S. Cl.** 135/121

(73) Assignee: **OPAC, LLC**, Stamford, CT

(57) **ABSTRACT**

(21) Appl. No.: **11/068,258**

(22) Filed: **Feb. 28, 2005**

Related U.S. Application Data

(63) Continuation-in-part of application No. 10/793,369,
filed on Mar. 4, 2004.

Foreign Application Priority Data

Feb. 27, 2004 (CN) 200420020474.4
Mar. 12, 2004 (CN) 200420020757.9

A canopy has a frame with a plurality of legs for defining a main area of protection, an auxiliary leg for defining an auxiliary area of protection adjacent the main area of protection, the auxiliary leg capable of being removed and a roof frame supported by the uprights. A tarp, secured to the frame, has a main section for covering the main area, and an auxiliary section adjacent the main section. The auxiliary section is (i) extendable between the legs and the auxiliary leg to cover the auxiliary area, (ii) extendable between the legs and the support surface to provide additional cover to the main area as a wall, and (iii) storable such that only the main section covers the main area and the at least one auxiliary leg is removed.

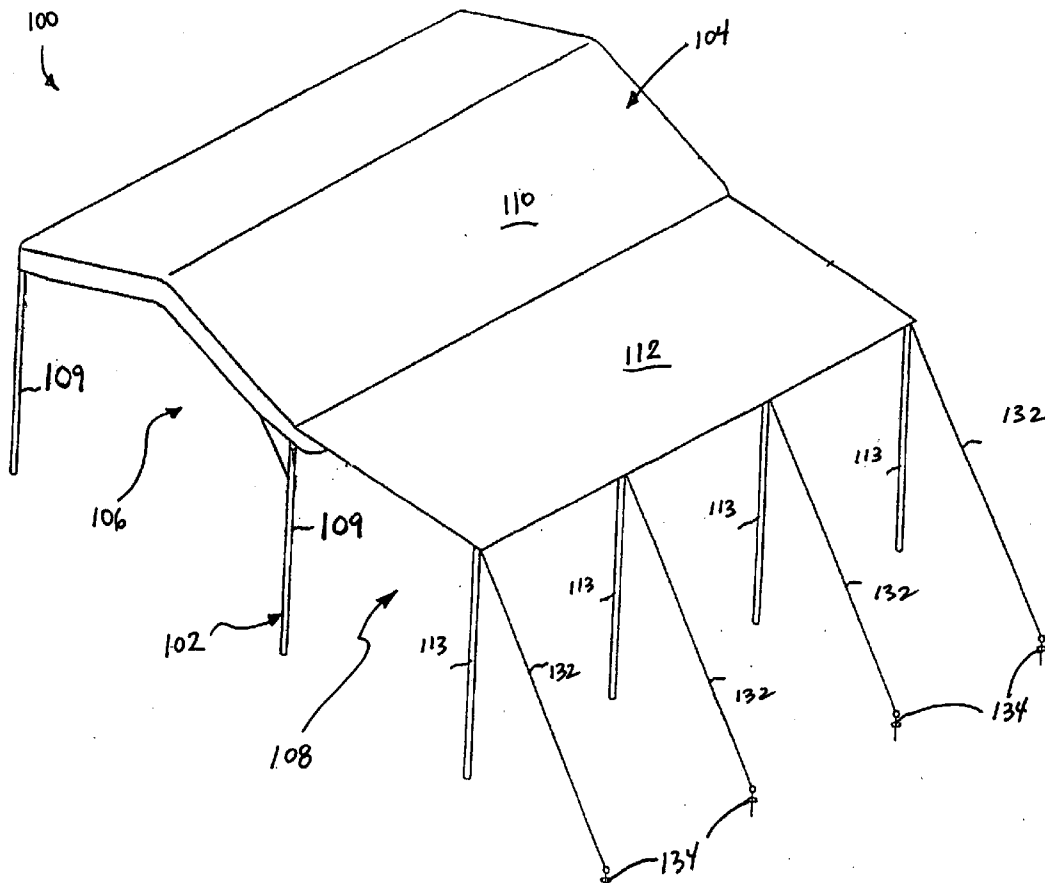

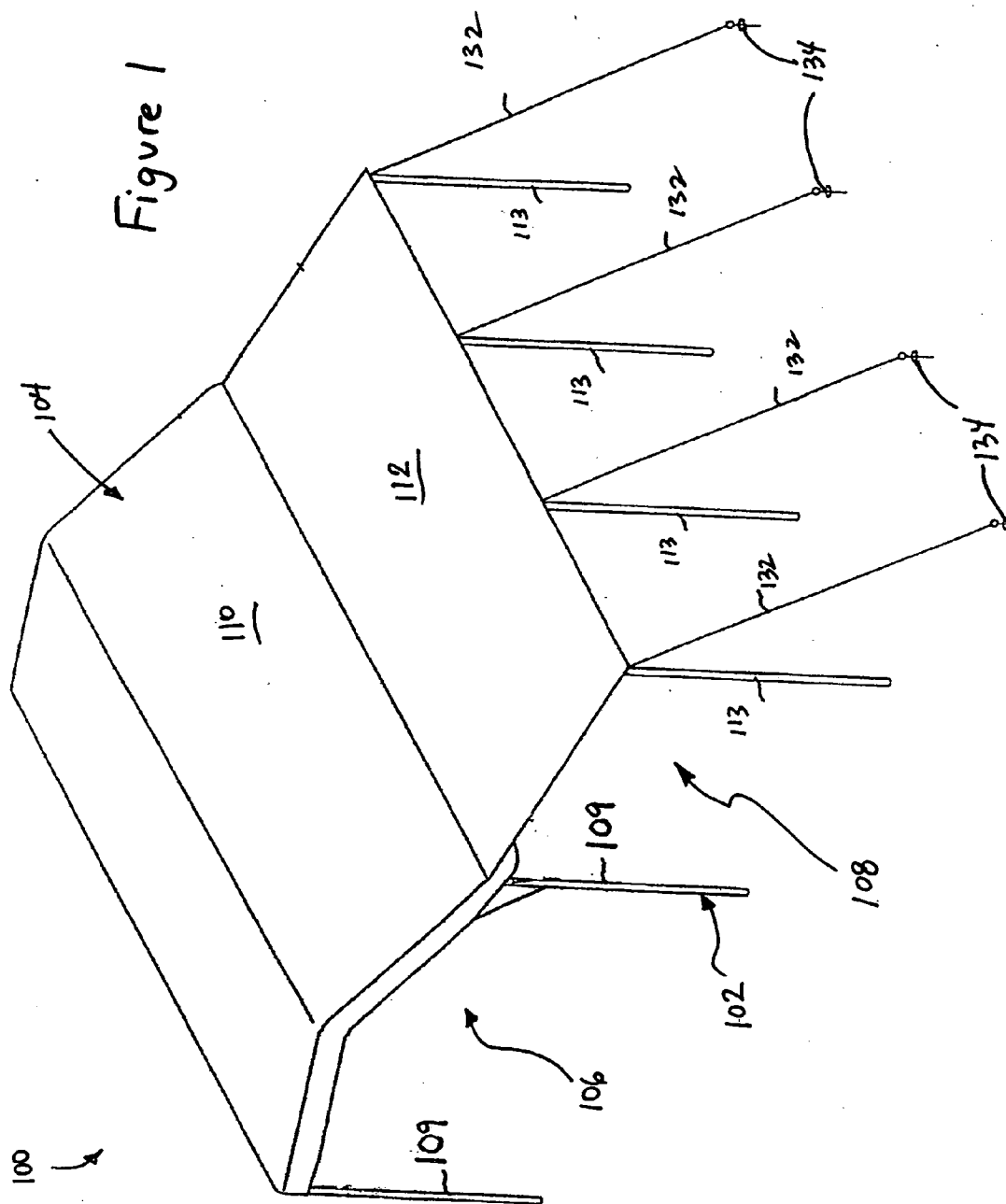
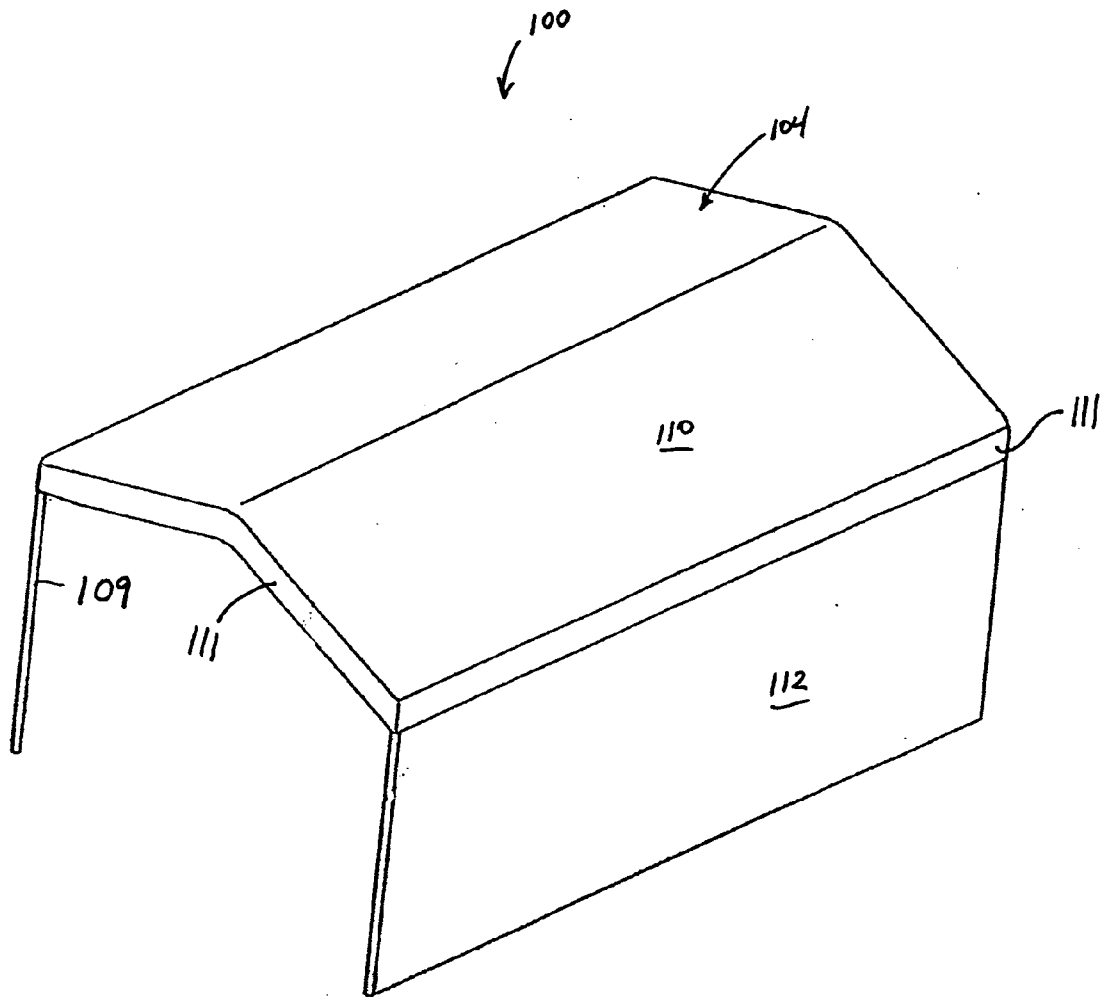
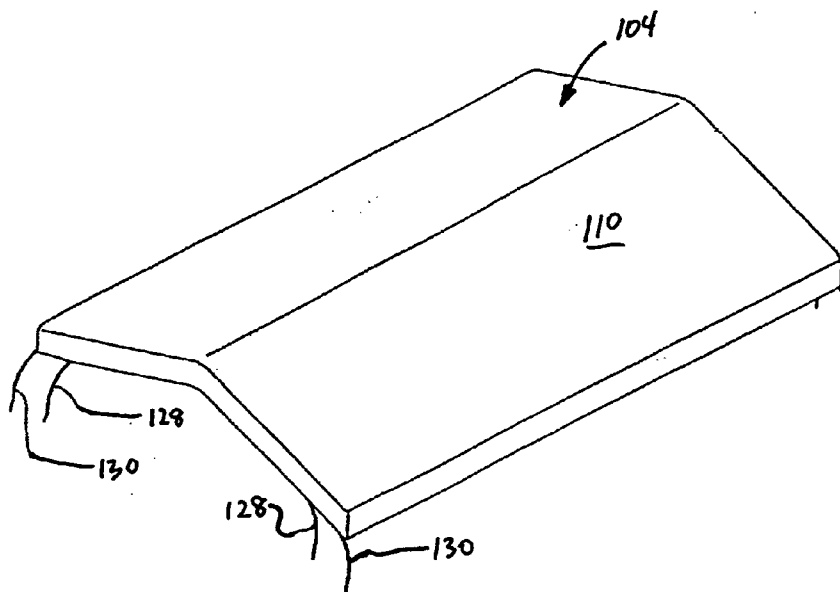
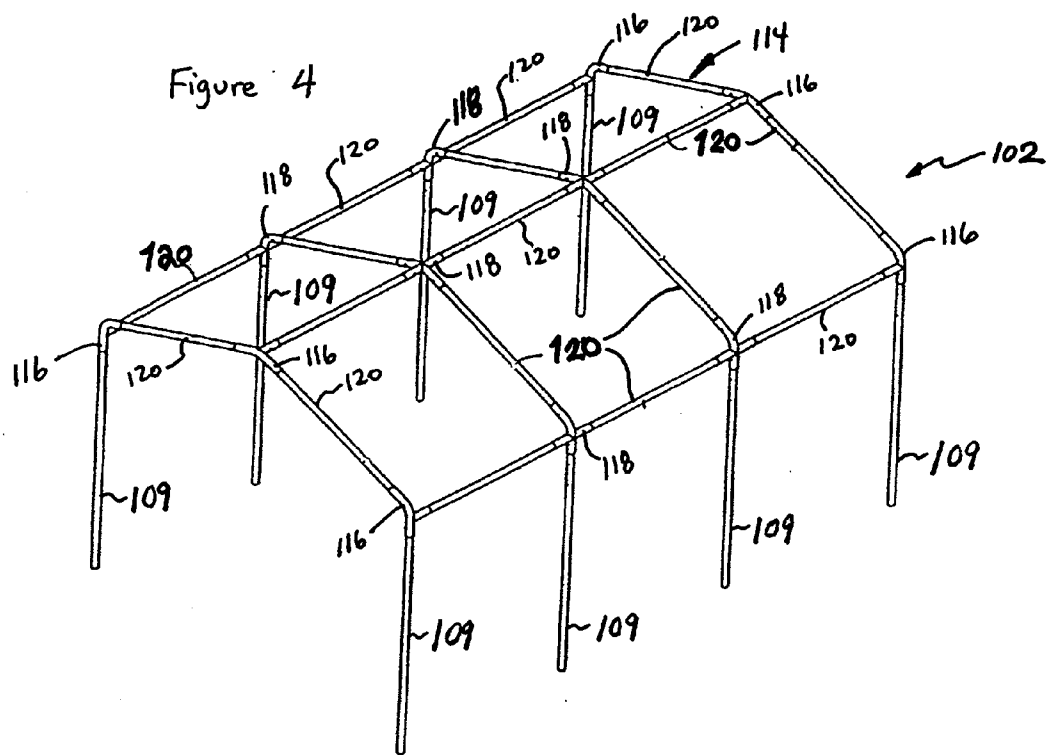

Figure 2





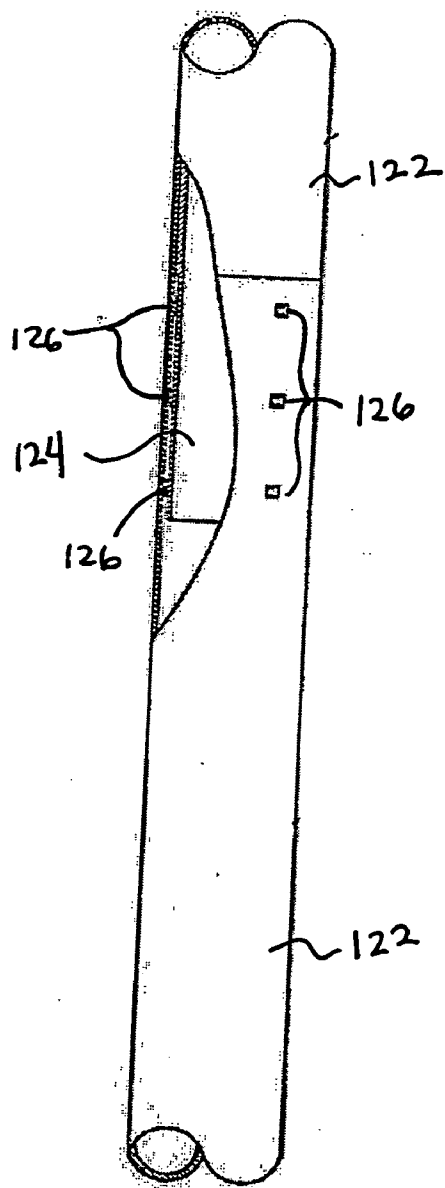

Figure 6

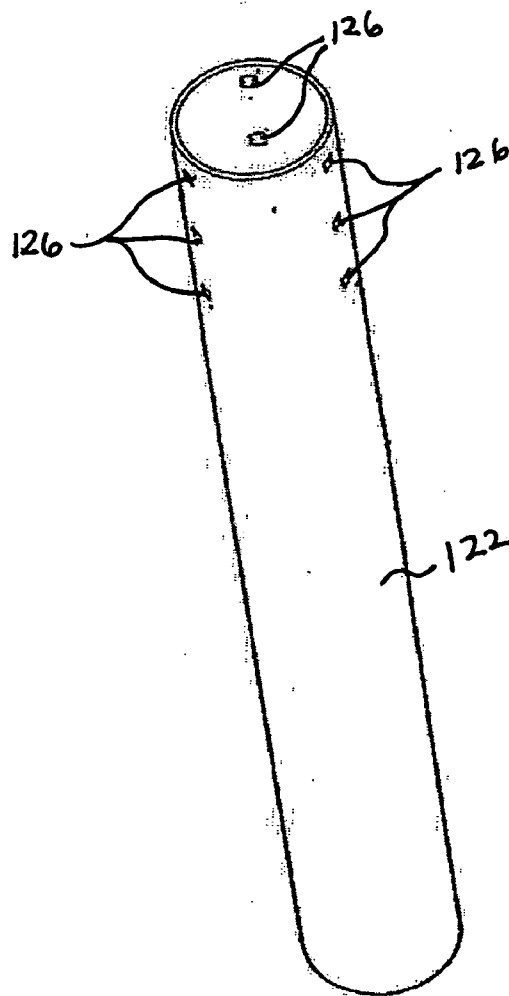

Figure 5

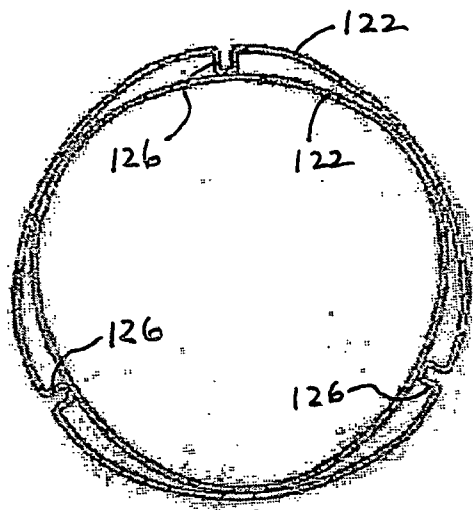

Figure 7A

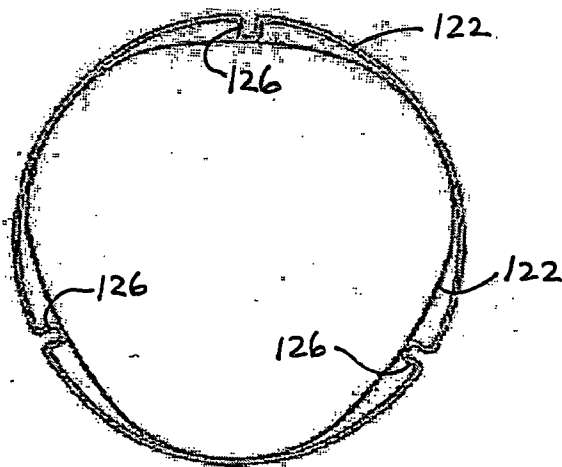

Figure 7B

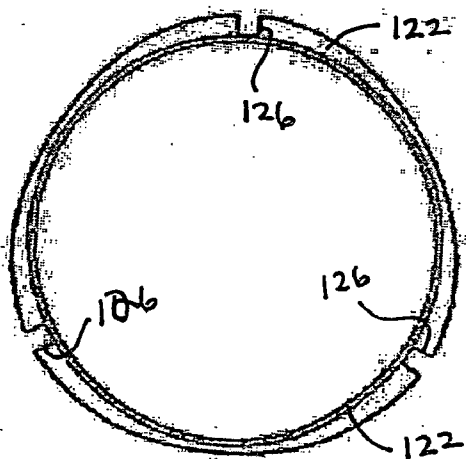

Figure 7C

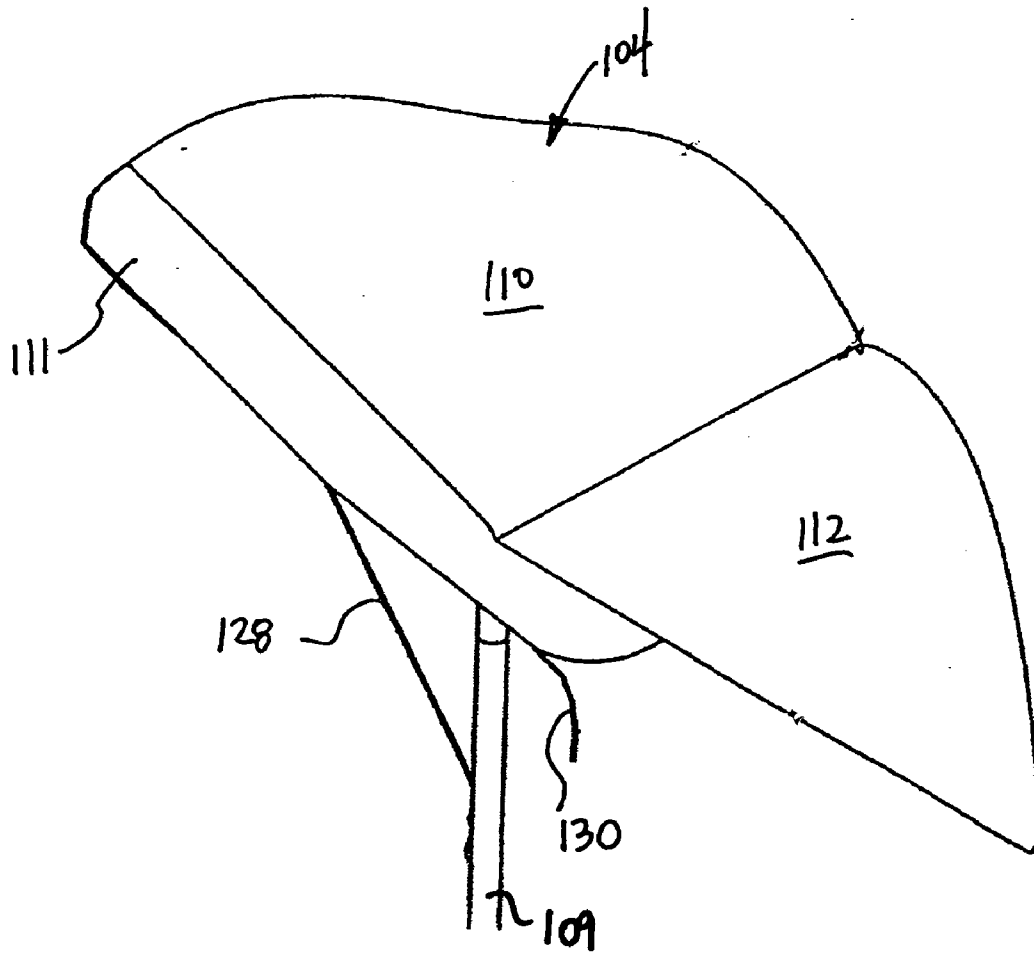
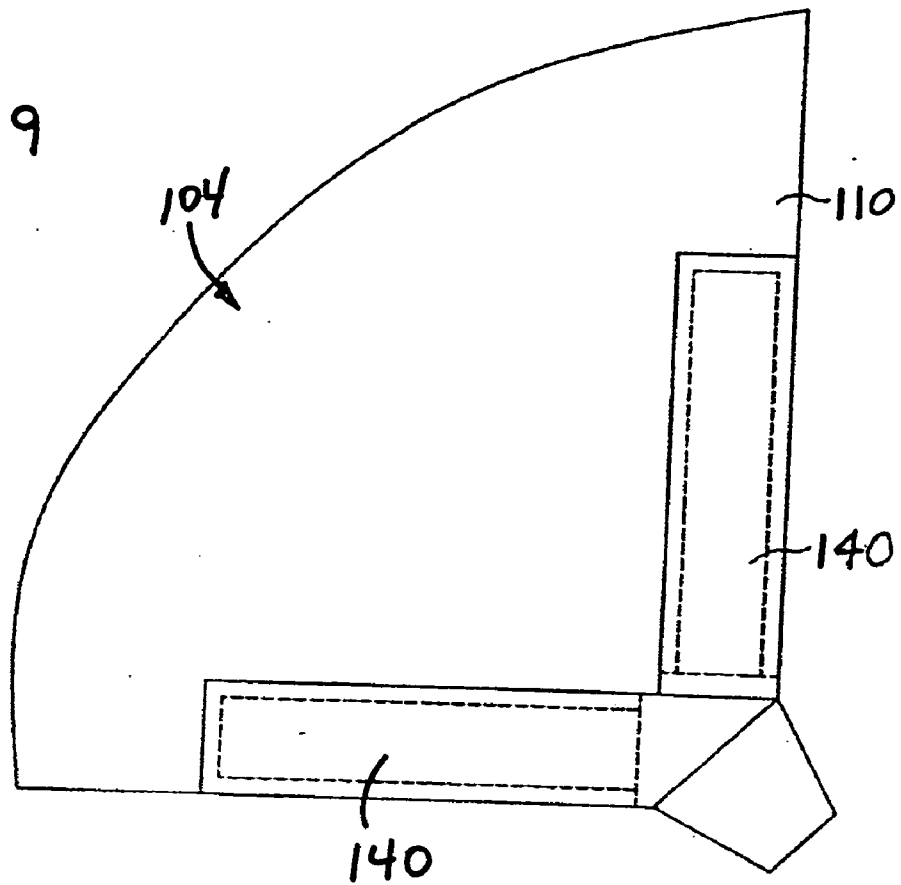

Figure 8

Figure 9



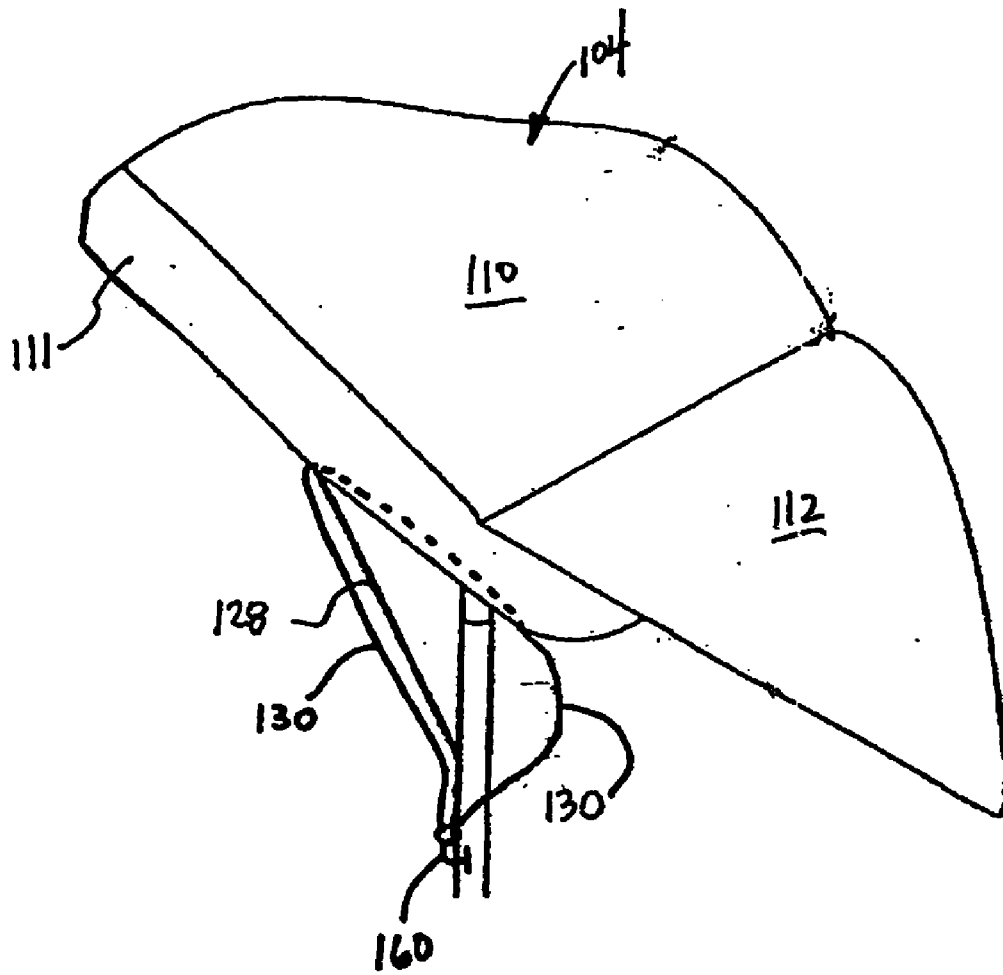

Figure 10

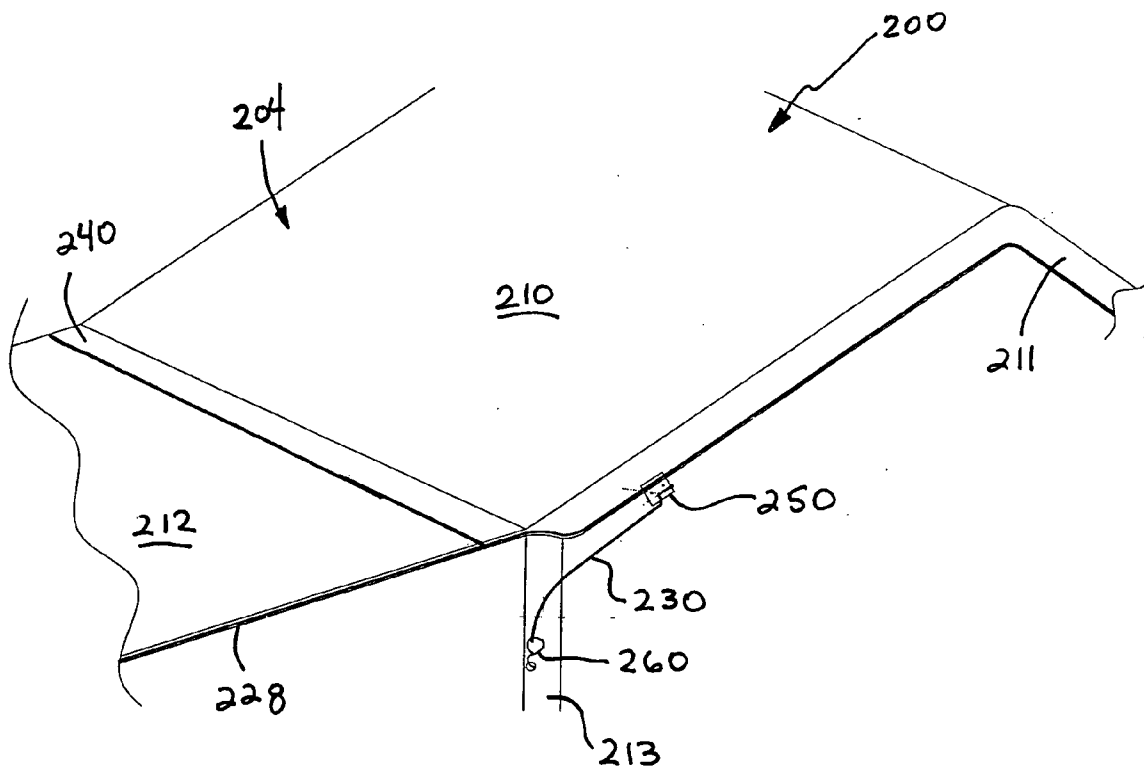

Figure 11

Figure 12A

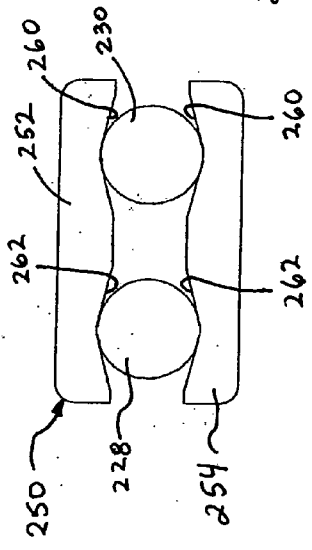

Figure 12B

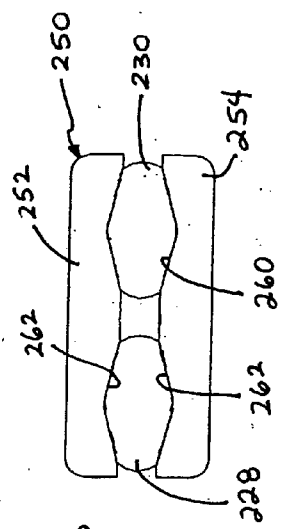

Figure 12C

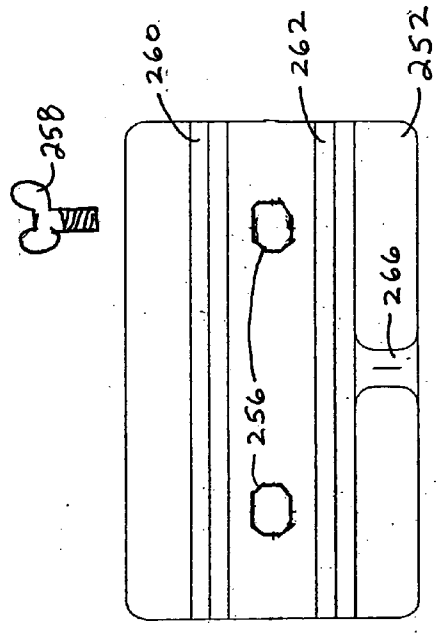

Figure 12D

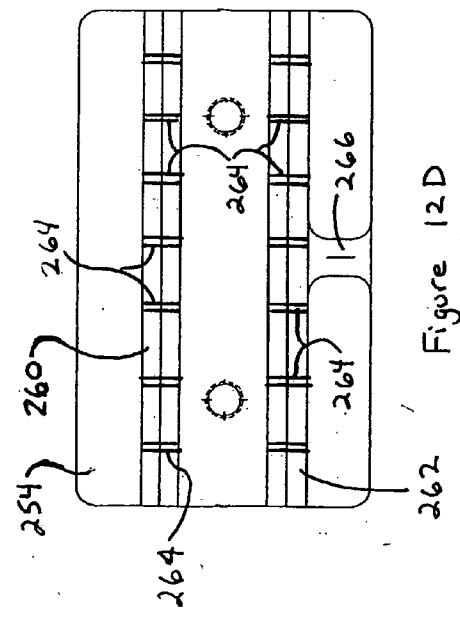
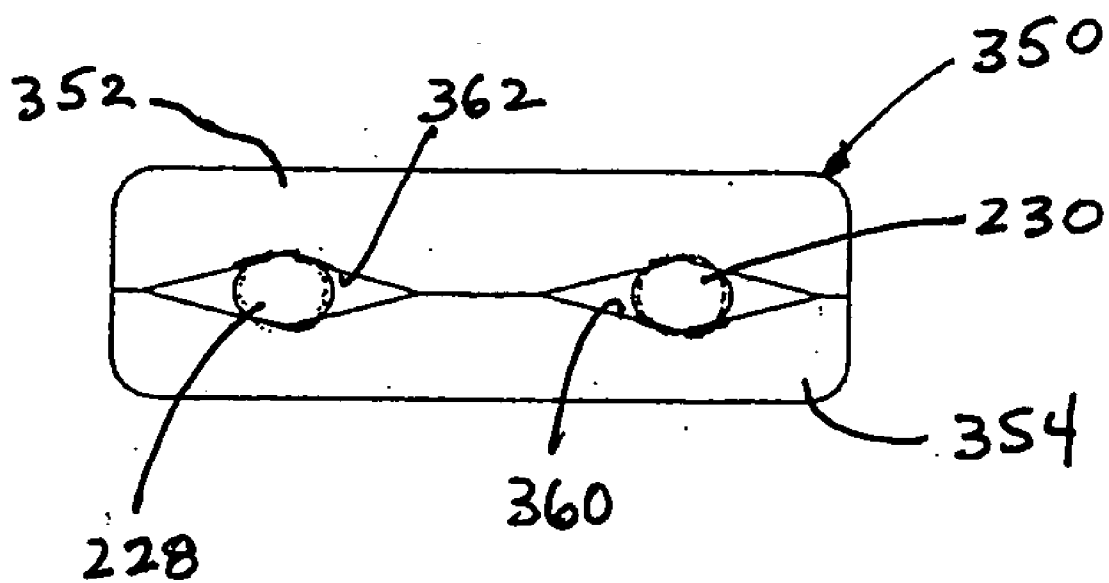

Figure 13



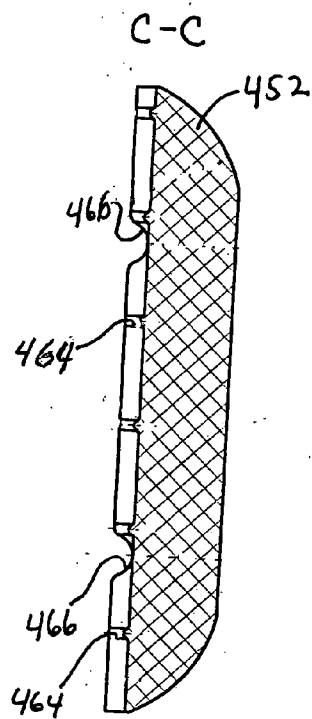
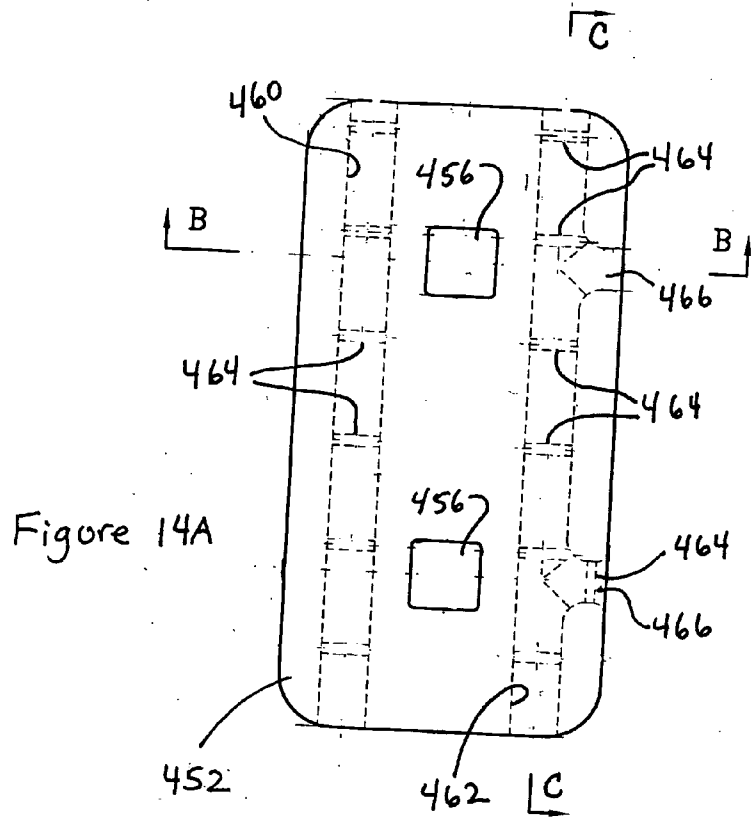
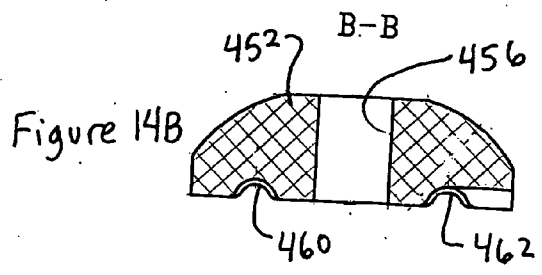

Figure 14A

Figure 14C

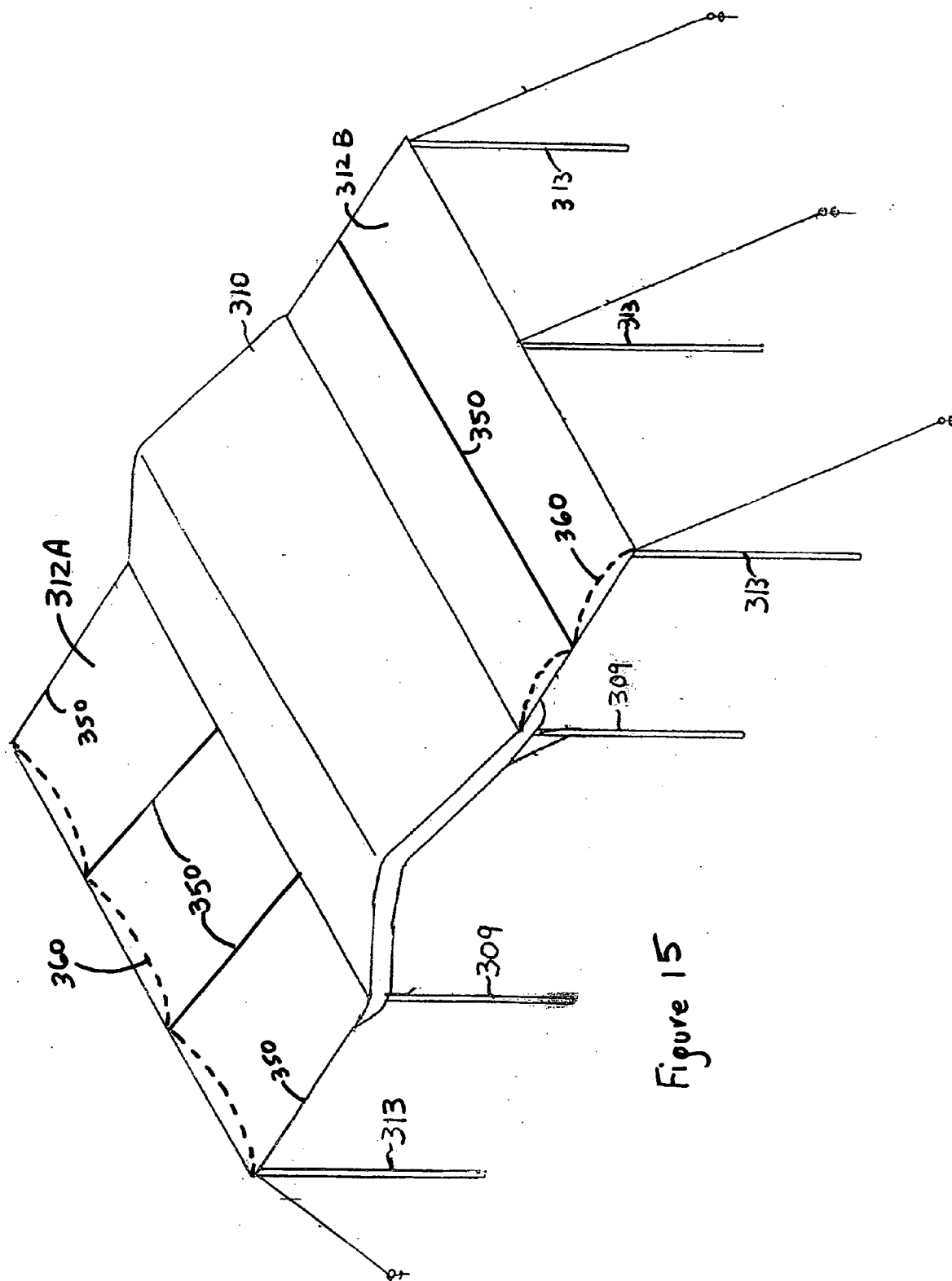

Figure 15

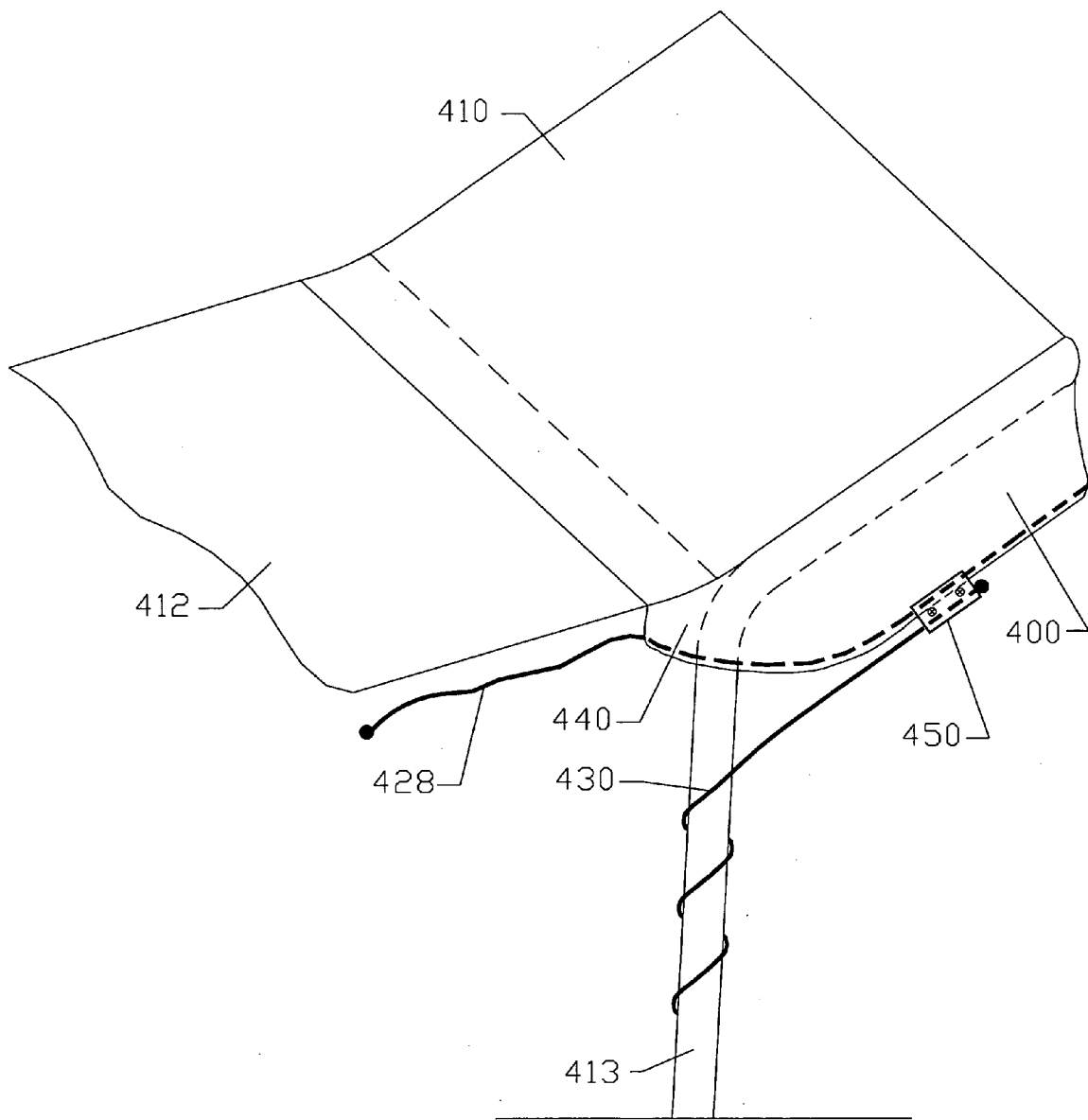

FIGURE 16

SHELTER HAVING AN EXTENDABLE ROOF

CROSS-REFERENCE TO RELATED APPLICATIONS

[0001] This application claims priority to Chinese Patent Application Nos. 200420020474.4, filed Feb. 27, 2004, and 200420020757.9, filed Mar. 12, 2004, each of which is incorporated herein by reference. This application also claims priority to U.S. patent application Ser. No. 10/793,369 filed Mar. 4, 2004, which is incorporated herein by reference.

BACKGROUND OF THE INVENTION

[0002] 1. Field of the Invention

[0003] The subject disclosure relates generally to shelters, and more particularly to an improved shelter that can provide additional protection when desired. Even more particularly, the subject disclosure relates to a shelter including a canopy that selectively extends.

[0004] 2. Background of the Related Art

[0005] Over the years, many tents and other shelters having collapsible frames have been introduced. Such structures are commonly used to provide shelter during camping trips, picnics, parties, military operations, and other outdoor activities. One advantageous feature of such structures is their ability to provide relief from weather elements when desired but allow removal when no longer needed.

[0006] However, prior art shelters have several problems. The shelters are unable to vary their configuration easily to suit varying demands. Some prior shelter frames also allow the overlying canopy to sag in an unsightly manner or be blown loose. Moreover, varying the configuration can be a challenging task even when multiple people are involved in the assembly. In view of these apparent shortcomings, many attempts at overcoming these difficulties have been patented, such as: U.S. Pat. Nos. 4,779,635; 5,511,572; 5,555,681; 5,632,293; 5,638,853; 5,701,923; 5,797,412; 5,813,425; and 6,173,726 (each of which is incorporated herein by reference in their entirety).

[0007] U.S. Pat. No. 5,555,681 to Cawthon discloses a building system that is modular in that a plurality of differently shaped buildings **10, 12** may be constructed from the same basic part set. The foundation of the buildings **10, 12** includes base plates **14** and headers **16** that are oriented horizontally. Vertical stud members **18** extend vertically between the base plates **14** and headers **16**. Connectors **22** couple the components **14, 16, 18** together. Rafters **20** also terminate within the connectors **22** to form a roof structure. Wall panels **24** and roof panels **26** enclose the buildings **10, 12** and are selectively extendible from and retractable into the respective associated base plate members **14** and headers **16**. This is an essential purpose of the buildings of Cawthon to selectively store the panels **24, 26** to allow enjoyment of ambient weather. However, once the building takes shape, major effort is required to reconfigure the space. Thus, it would be desirable to build a shelter that can quickly and easily be modified to have additional space that is protected from the elements.

SUMMARY OF THE INVENTION

[0008] The present disclosure is directed to a canopy including a frame assembly including a plurality of legs

upstanding from a support surface. A resilient tarp covers the frame assembly. The resilient tarp has a main section for substantially defining a main area of protection, an auxiliary section for substantially defining an auxiliary area of protection and an overhang. A plurality of cords attach the resilient tarp to the frame assembly in a plurality of positions including: i) a set up position wherein the main section substantially covers the main area and the auxiliary section is stored; and ii) a set up position wherein the main section substantially covers the main area, the auxiliary section substantially covers the auxiliary area, and at least one of the plurality of cords extends at least partially over the auxiliary area.

[0009] Another aspect of the invention is a canopy providing shelter on a support surface. The canopy includes a frame assembly with a plurality of legs for defining a main area of protection, two auxiliary legs for defining an auxiliary area of protection adjacent the main area of protection, and a roof frame supported by the plurality of uprights. A resilient tarp secures to the frame assembly. The tarp includes a main section for substantially covering the main area, and an auxiliary section adjacent the main section, wherein the auxiliary section is (i) extendable between the plurality of legs and the at least one auxiliary leg to substantially cover the auxiliary area, (ii) extendable between the plurality of legs and the support surface to provide additional cover to the main area, and (iii) storable such that only the main section substantially covers the main area.

[0010] Still another aspect of the invention is a canopy having a plurality of upright assemblies for defining a main area and an auxiliary area of protection, each upright having an interlocking male and female portion wherein the male portion includes at least one protuberance that causes at least one of the male and female portion to deform upon interlocking. A resilient tarp covering the main area and the auxiliary area whereby a plurality of cords attach the resilient tarp to the frame assembly in a plurality of positions including: i) a first position wherein the resilient tarp substantially covers the main area and the auxiliary area is exposed; and ii) a second position wherein the resilient tarp substantially covers the main area and the auxiliary area. Still another aspect of the invention is directed to a kit that allows a traditional canopy to be outfitted with an auxiliary area of protection.

[0011] It should be appreciated that the present invention can be implemented and utilized in numerous ways, including without limitation as a process, an apparatus, a system, a device, and a method for applications now known and later developed. These and other features of the system disclosed herein will become more readily apparent from the following description.

BRIEF DESCRIPTION OF THE DRAWINGS

[0012] So that those having ordinary skill in the art to which the disclosed system appertains will more readily understand how to make and use the same, reference may be had to the following drawings.

[0013] **FIG. 1** is a perspective view of an assembled collapsible shelter having one auxiliary area covered in accordance with a preferred embodiment of the subject disclosure.

[0014] FIG. 2 is a perspective view of the frame assembly of the shelter of FIG. 1 with the auxiliary portion of the tarp serving as a wall.

[0015] FIG. 3 is a perspective view of the tarp of the canopy of FIG. 1.

[0016] FIG. 4 is a perspective view of the frame assembly of FIG. 1.

[0017] FIG. 5 is a portion of a leg assembly of the frame assembly of FIG. 4.

[0018] FIG. 6 is a localized view of the interconnection of a male portion and female portion of a leg assembly of the frame assembly of FIG. 4.

[0019] FIGS. 7A-C are varying possible cross-sectional views of the interconnection of the leg assembly of FIG. 6.

[0020] FIG. 8 is a localized view of the connection of the tarp to the frame for the canopy of FIG. 1.

[0021] FIG. 9 is a detailed view of a preferred corner of the tarp of the canopy of FIG. 8.

[0022] FIG. 10 is a localized view of an alternative connection of a tarp to a frame for a canopy in accordance with a preferred embodiment of the subject disclosure.

[0023] FIG. 11 is a localized view of another alternative connection of a tarp to a frame for a canopy in accordance with a preferred embodiment of the subject disclosure.

[0024] FIG. 12A is an end plan view of a clamp for a canopy in accordance with a preferred embodiment of the subject disclosure in a partially assembled state.

[0025] FIG. 12B is an end plan view of the clamp of FIG. 12A in an assembled state.

[0026] FIG. 12C is an inside plan view of the nut side of the clamp of FIG. 12A.

[0027] FIG. 12D is an inside plan view of the bolt side of the clamp of FIG. 12A.

[0028] FIG. 13 is an end plan view of another clamp for a canopy in accordance with a preferred embodiment of the subject disclosure in an assembled state.

[0029] FIG. 14A is an inside plan view of one portion of another clamp for a canopy in accordance with a preferred embodiment of the subject disclosure.

[0030] FIG. 14B is a cross-sectional view of the portion of FIG. 14A along line B-B.

[0031] FIG. 14C is a cross-sectional view of the portion of FIG. 14A along line C-C.

[0032] FIG. 15 is a perspective view of an assembled collapsible shelter having two auxiliary area covered in accordance with a preferred embodiment of the subject disclosure.

[0033] FIG. 16 is a localized view of still another alternative connection of a tarp to a frame for a canopy in accordance with a preferred embodiment of the subject disclosure.

DETAILED DESCRIPTION OF PREFERRED EMBODIMENTS

[0034] The present invention overcomes many of the prior art problems associated with canopies and temporary shel-

ters. The advantages, and other features of the system disclosed herein, will become more readily apparent to those having ordinary skill in the art from the following detailed description of certain preferred embodiments taken in conjunction with the drawings which set forth representative embodiments of the present invention and wherein like reference numerals identify similar structural elements. For simplicity and clarity throughout this disclosure, only enough reference numerals with tag lines that are sufficient for understanding have been shown.

[0035] Referring to FIG. 1, a canopy 100 in accordance with the present disclosure includes a frame assembly 102 for mounting a tarp 104 thereon. The canopy 100 provides shelter from the elements yet can be easily erected and modified for varying the amount and configuration of protection from weather elements. The canopy 100 is shown in the raised, unfolded or "set-up" position with the tarp 104 fully extended. As a result, two areas of protection result: i) the main section 106; and ii) the auxiliary section 108. A main portion 110 of the tarp 104 covers the main section 106 and another auxiliary portion 112 covers the auxiliary section 108. Preferably, the tarp 104 also includes a hem or overhang portion 111. In another embodiment, the overhang portion 111 extends the full length of the tarp 104.

[0036] Referring now to FIG. 2, the tarp 104 is arranged so that the canopy 100 only provides protection for main section 106. As shown, the auxiliary portion 112 of the tarp 104 that alternatively covers the auxiliary section 108 becomes a wall for the canopy 100. When configured as a wall, the auxiliary portion 112 may attach to the frame assembly 102 by cords, attach to another portion of tarp such as an adjacent wall by a zipper and the like.

[0037] In a preferred embodiment shown in FIG. 3, the auxiliary portion 112 of the tarp 104 is detached from the main portion 110 when not desired. As a result, the canopy 100 appears like a traditional prior art canopy. The means for detaching the auxiliary portion 112 may be a combination of hook/loop fabric, snaps, clips, straps and holes, a zipper, and the like. In other embodiments, the auxiliary portion 112 is rolled or folded at suspended from the frame assembly 102 in a substantially concealed manner. The tarp 104 may be formed of any of a number of different transparent, translucent, and/or opaque materials such as canvas, non-woven sheets or as woven fabric materials. Plastic may also be used to form the canopy, as desired, and the canopy may include a design or designs thereon (not shown), depending upon the nature of the material used for the canopy and other factors.

[0038] Referring to FIG. 4, the frame assembly 102 includes eight leg assemblies 109 adapted to rest on a support surface to substantially define the main section 106 and support a roof assembly 114. For example, it should be understood that the frame assembly 102 and, thereby the canopy 100, according to the subject disclosure may include more or less than eight leg assemblies 106 to form configurations other than cubic and the like. Preferably, each of the leg assemblies 109 is the same. The roof assembly 114 includes a plurality of 3-way connectors 116 and 4-way connectors 118 for interconnecting horizontal and angled rails 120 upon the leg assemblies 109.

[0039] Referring again to FIG. 1, additional auxiliary leg assemblies 113 are required in order to further support the auxiliary portion 112. Preferably, auxiliary cords 132 and

anchors **134** are attached to the auxiliary leg assemblies **113** and the auxiliary portion **112** attaches to the leg assemblies **113** to further support the canopy **100**. In another embodiment, the cords **132** are only attached to the auxiliary portion **112** and in another, the cords **132** are attached to the leg assemblies **113** and the tarp **104**. It is envisioned that intermediate the leg assemblies **113**, the auxiliary portion **112** may form a plurality of troughs for desirably channeling rainwater off the sides of the shelter **100**. Each of the frame assembly components is preferably formed of a plastic material. It has been found that polyvinyl chloride (pvc) plastics, particularly in high density configuration, are excellent for use in the manufacture of the components of the present structure because pvc plastics are impervious to corrosion and hold up well in extremes of loading, sunlight, weather, and other conditions. Other materials, such as powder coated metal tubing, may be substituted for the above pvc or other plastics, as desired.

[0040] Referring to FIGS. 5 and 6, the leg assemblies **109**, **113** and rails **120** preferably include multiple portions **122**. Each portion **122** may terminate in a smaller neck **124** to facilitate insertion and coupling. Further, to interlock the portions **122**, protuberances **126** are formed in the inner radius of a portion **122**. It is also envisioned that the 3-way connectors **116** and 4-way connectors **118** may utilize protuberance advantageously as well. In a preferred embodiment, the protuberances form a line and are spaced half an inch apart along the line and equidistant around the circumference. In another embodiment, there is only a single line of three protuberances. In still another embodiment, only a single protuberance is required. Alternatively, the location and number of protuberances may be varied as would be appreciated by those of ordinary skill in the art based upon review of the subject disclosure.

[0041] Referring now to FIG. 7A, when the portions **122** have substantially equivalent wall thickness, the protuberances **126** cause each portion **122** to deform. The portion deformation creates tension that allows for easy assembly and disassembly of the portions. When the outer portion **122** has a thicker wall compared to the inner portion **122** mated therewith, the deformation is largely isolated to the inner portion as shown in FIG. 7B. Conversely, when the inner portion **122** has a thicker wall compared to the outer portion **122** mated therewith, the deformation is largely isolated to the outer portion as shown in FIG. 7C.

[0042] Referring to FIGS. 8 and 9, after assembling the frame assembly **102**, the tarp **104** is secured thereto. It will be appreciated by those of ordinary skill in the art that each corner of the canopy **100** includes an arrangement as that shown in FIG. 8. In a preferred embodiment, the tarp **104** is attached to the frame assembly **102** by a plurality of cords **128**, **130**. The cords **128**, **130** pass through a sleeve (not shown) formed in the overhang portion **111** of the tarp **104**. Cord **128** passes out of the sleeve and secures the main portion **110** to the frame assembly **102**. Means for attaching the cords **128**, **130** to the frame assembly are shown in U.S. Pat. No. 6,367,495 issued Apr. 9, 2002, U.S. patent application Ser. No. 10/282,283 filed Oct. 28, 2002 and the applications noted above, each of which is incorporated herein by reference.

[0043] As best seen in FIG. 9, additional fabric in the corners of the overhang portion **111** is layered to provide

strength and form an edge sleeves **140**. The edge sleeves **140** extend to the end of the overhang portion **111**. Although cord **128** exits the sleeve substantially above the main section **106**, cord **130** passes through an edge sleeve **140** of the main portion substantially above the auxiliary section **108**. The cord **130** is also secured to the frame assembly **102**. As a result, the tarp **104** is attractively and effectively retained against the frame assembly **102**. In another embodiment, the cords **128**, **130** are elastic and/or attach within holes formed in the frame assembly **102**. In another embodiment, the separately formed auxiliary portion **112** is directly sashed or otherwise secured to the frame assembly **102**. In the embodiment where the overhang portion **111** extends the full length of the tarp **104**, a cord secures the auxiliary section **112** to a leg assembly **113**. In still another embodiment, only cord **128** is used to secure the tarp **104**.

[0044] Referring now to FIG. 10, an alternative method for securing a corner of the main portion **110** to the frame assembly **102** is shown. The cords **128**, **130** attach to an eye-hook **160**. However, cord **130** does not pass the entire length of the main portion **110**. Instead, cord **130** merely passes through the edge sleeve **140** so that both ends of the cord **130** attach to the eye-hook **160**. Thus, cord **130** forms a short loop through the edge sleeve **140** for securing the tarp **104** to the leg assembly **109** at the corner. In another embodiment, a single cord **128** exits normally, secures to the eye-hook **160** then passes through the edge sleeve **140** so that the short loop is accomplished with a single cord. In still another embodiment, the single cord **128** passes first through the edge sleeve **140** to the eye-hook **160** and is secured thereto. A remaining portion of the single cord **128** then is passed through the edge sleeve **140** again to further strengthen the attachment of the tarp **104** to the frame assembly **102**.

[0045] Referring to FIG. 11, a valence **240** serves to prevent water from passing between the main portion **210** and the auxiliary portion **212**. In one embodiment, the valence **240** forms a gutter to channel water off the front and back corners of the main portion. In another embodiment, the valence **240** forms a pocket for retaining a cord for further attachment to the leg assembly **213**. Another alternative method for securing a corner of a main portion **210** to a canopy **200** is also shown in FIG. 11. As will be appreciated by those of ordinary skill in the pertinent art, the canopy **200** utilizes the same principles of the canopy **100** described above. Accordingly, like reference numerals preceded by the numeral "2" instead of the numeral "1" are used to indicate like elements whenever possible. As shown, a clamp **250** couples the cords **228**, **230** together. In an alternative embodiment, the clamp **250** attaches directly to the main portion **210** of the tarp **204**. In both embodiment, rope **230** and clamp **250** can be used to not only secure the tarp **204**, but facilitate rerouting rope **228** during adding and removing the auxiliary portion **212**.

[0046] Referring now to FIGS. 12A-D, the clamp **250** has opposing portions **252**, **254** that form respective hollows **260** for receiving cords **228**, **230**. The opposing portions **252**, **254** are coupled together by pair of nuts **256** and bolts **258**. To attach the clamp **250**, the opposing sides **252**, **254** are loosely coupled together and cords **228**, **230** are passed through the hollows **260** as shown in FIG. 12A. The tarp **204** may or may not be included between the opposing portions **252**, **254**. Upon tightening the bolts **258**, the cords

228, 230 are compressed and retained between the opposing portions **252, 254**. As a result, the auxiliary portion **212** may be easily added to the main portion **210** because the cord **228** may serve the intended purpose of securing the outermost corner while the additional cord **230** secures the tarp **204** at the corner of the main portion **210**. This provides the further benefit that the auxiliary portion **212** may be added to canopy **200** not originally intended to include the auxiliary portion **212**.

[0047] The hollows **260** also include bumps or ridges **264** formed transverse to the cords **228, 230** to increase the holding retention thereon. The ridges **264** may be formed on one or both of the opposing sides **252, 254**. Preferably, the opposing sides **252, 254** form a pathway **266** so that the cord **230** can centrally exit the clamp **250**. As a result, the weight carried by the clamp **250** is evenly distributed. In the embodiment shown, the hollows **260** and pathways **266** are shaped and configured to receive cords having an 8 mm diameter. It is envisioned that the side **252** may include depressions for insertion of the nuts **256** therein. The clamp **250** is preferably constructed from a strong plastic, aluminum or the like.

[0048] Referring to FIG. 13, another alternative clamp **350** sized for receiving 3 mm. cords is shown. As will be appreciated by those of ordinary skill in the pertinent art, the clamp **350** utilizes the same principles of the clamp **250** described above. Accordingly, like reference numerals preceded by the numeral "3" instead of the numeral "2" are used to indicate like elements whenever possible.

[0049] Referring to FIGS. 14A-C, still another alternative side **452** of a clamp is shown. As will be appreciated by those of ordinary skill in the pertinent art, the side **452** utilizes the same principles of the clamp **450** described above. Accordingly, like reference numerals preceded by the numeral "4" instead of the numeral "2" are used to indicate like elements whenever possible. The side **452** includes two pathways **466** for varying the point at which the cord **230** exits. Of course, the cord **230** may not exit via either pathway **466** as may be desired for the particular configuration.

[0050] Referring to FIG. 15, a perspective view of an assembled collapsible shelter **200** having two auxiliary areas **208** covered in accordance with a preferred embodiment of the subject disclosure is shown. As will be appreciated by those of ordinary skill in the pertinent art, the shelter **300** utilizes the same principles of the shelter **100** described above. Accordingly, like reference numerals preceded by the numeral "3" instead of the numeral "1" are used to indicate like elements whenever possible to simplify the subject description.

[0051] The auxiliary portions **312A, 312B** include one or more stiffening ridges **350**. The stiffening ridge **350** may be a seam sewn into the fabric, a rod inserted into a sleeve or the like. The purpose of the stiffening ridge **350** is to control the manner in which rainwater may collect on the auxiliary portion **312**. On auxiliary portion **312A**, the stiffening ridge **350** is shaped and formed to direct collected water towards the sides of the shelter **300**. Alternatively on auxiliary portion **312B**, the stiffening ridge **50** is shaped and formed to direct collected water towards the front of the shelter **300**. Dashed lines **360** indicate a manner in which the auxiliary portions **312A, 312B** sag to collect rainwater. Preferably,

the auxiliary portions **312A, 312B** sag to a certain point at which deformation occurs. During deformation, the water is released to allow the auxiliary portions **312A, 312B** to substantially return to shape. In another embodiment, the auxiliary sections **312A, 312B** do not have any stiffening ridges but are allowed to sag/collect water and deform to release. In still another embodiment, the outer legs **313** are relatively shorter than the inner legs **309**. As a result, the auxiliary portions **312A, 312B** are slanted to further increase the propensity of water to flow off to the sides of the shelter **300**.

[0052] Referring now to FIG. 16, as will be appreciated by those of ordinary skill in the pertinent art, the canopy **400** utilizes the same principles of the canopies described above. Accordingly, like reference numerals preceded by the numeral "4" instead of the numerals "1", "2" or "3" are used to indicate like elements whenever possible. A valence **440** serves to prevent water from passing between the main portion **410** and the auxiliary portion **412**. To assembly the auxiliary section **412**, a clamp **450** couples the cords **428, 430** together while the cord **428** is secured to the leg **413**. Subsequently, the cord **428** can be released so that the valence **440** can be raised to rest on the auxiliary section **412** and prevent rain and wind from passing therebetween. The cord **428** may be passed onto the auxiliary section **412** as shown and, optionally coupled to the cord **428** from the opposing corner. Alternatively, the cord **428** is rolled for storage within the valence **440**. It is envisioned that a plurality of mechanisms may serve the purpose of the clamp **450** as would be appreciated by those of ordinary skill in the pertinent art based upon review of the subject disclosure. In an alternative embodiment, the valence **440** includes a hole (not shown) reinforced with a grommet at the approximate location of the leg **413**. As a result, the cord **428** can exit the valence **440** and secured the tarp to the leg **413** while the very end of the valence **440** may still be raised onto the auxiliary portion **412**.

[0053] It is envisioned that numerous variations are possible beyond those specifically described here and such would be apparent to those of ordinary skill in the art based upon review of the subject disclosure. For example, the canopy may have two auxiliary sections on opposing sides of the main section. Of course, either or both auxiliary sections may be completely detachable. For another example, the main section of the canopy may be octagonal with a plurality of auxiliary sections that are various shapes such as triangular, trapezoidal and the like.

[0054] While the invention has been described with respect to preferred embodiments, those skilled in the art will readily appreciate that various changes and/or modifications can be made to the invention without departing from the spirit or scope of the invention as defined by the appended claims.

What is claimed is:

1. A canopy comprising:
 - a frame assembly including a plurality of legs upstanding from a support surface and a roof assembly connected to the legs, the roof assembly having sides and a peaked front and back;
 - a resilient tarp for covering the frame assembly, the resilient tarp having a main section for substantially

defining a main area of protection, an auxiliary section for substantially defining an auxiliary area of protection and an overhang portion along the front and back; and a plurality of cords for attaching the resilient tarp to the frame assembly in a plurality of positions including: i) a set up position wherein the main section substantially covers the main area, a portion of the main section extends out of the main area and the auxiliary section substantially covers the auxiliary area such that the overhang portion is snugly secured; and ii) a stored position wherein the auxiliary section is stored, the main section substantially covers the main area such that the overhang portion is snugly secured, and the portion of the main section receives at least one of the plurality of cords to secure the resilient tarp to the frame assembly.

2. A canopy as recited in claim 1, wherein the plurality of positions further includes an enclosed position wherein the main section substantially covers the main area and the auxiliary section forms a wall for further protecting the main area.

3. A canopy as recited in claim 1, wherein each leg has an interlocking male and female portion wherein the male portion includes at least one protuberance that causes at least one of the male and female portion to deform upon interlocking.

4. A canopy as recited in claim 1, wherein the overhang portion of the tarp forms an edge sleeve for receiving at least one of the plurality of cords.

5. A canopy as recited in claim 1, wherein the tarp forms a valence parallel to the sides for preventing water from passing between the main section and the auxiliary area.

6. A canopy as recited in claim 1, wherein the auxiliary section of the tarp selectively sags to a point when water collects thereon, at the point of maximum sagging, the auxiliary section deforms to release the water.

7. A canopy as recited in claim 6, wherein the tarp forms at least one stiffening ridge and is slightly slanted for creating areas of water flow.

8. A canopy for providing shelter on a support surface comprising:

(a) a frame assembly having

- a plurality of legs for defining a main area of protection,
- at least one auxiliary leg for defining an auxiliary area of protection adjacent the main area of protection, the at least one auxiliary leg being capable of being easily and quickly removed; and
- a roof frame supported by the plurality of uprights; and

(b) a resilient tarp assembly secured to the frame assembly having

- a clamp assembly,
- a main section for substantially covering the main area, and
- an auxiliary section adjacent the main section, wherein the auxiliary section is (i) extendable between the plurality of legs and the at least one auxiliary leg to substantially cover the auxiliary area by using the clamp assembly for securing an additional cord to the at least one cord to selectively secure the tarp, (ii) extendable between the plurality of legs and the

support surface to provide additional cover to the main area as at least a partial wall, and (iii) storable such that only the main section substantially covers the main area and the at least one auxiliary leg is removed.

9. A canopy as recited in claim 8, further comprising at least one cord with an earth anchor for securing the at least one auxiliary leg to the support surface.

10. A canopy as recited in claim 8, further at least one cord for securing the resilient tarp to the frame assembly.

11. A canopy as recited in claim 10, wherein the clamp assembly includes opposing sides that are secured about the cords by fasteners.

12. A canopy as recited in claim 11, wherein each opposing side has at least one hollow for a cord.

13. A canopy as recited in claim 12, wherein the opposing sides form a pathway to allow the additional cord to exit the clamp.

14. A canopy as recited in claim 8, wherein each leg has an interlocking male and female portion wherein the male portion includes at least one protuberance that causes at least one of the male and female portion to deform upon interlocking.

15. A canopy comprising:

- a plurality of upright assemblies for defining a main area and an auxiliary area of protection, each upright having an interlocking male and female portion wherein the male portion includes at least one protuberance that causes at least one of the male and female portion to deform upon interlocking;

- a resilient tarp for covering the main area and the auxiliary area;

- a plurality of cords for attaching the resilient tarp to the frame assembly in a plurality of positions including: i) a first position wherein the resilient tarp substantially covers the main area and the auxiliary area is exposed; and ii) a second position wherein the resilient tarp substantially covers the main area and the auxiliary area.

16. A canopy as recited in claim 15, further comprising at least one stiffening ridge formed in the resilient tarp.

17. A canopy as recited in claim 15, further comprising a valence formed in the resilient tarp and connected such that the valence is fully secured in the first position and able to raise and rest upon the auxiliary area in the second position.

18. An auxiliary section for attachment to a main canopy comprising:

- a tarp extendable between a plurality of legs of the main canopy and capable of substantially cover an auxiliary area;

- at least one auxiliary leg for providing support to the tarp; and

- means for selectively attaching the tarp to the plurality of leg and the at least one auxiliary leg.

19. An auxiliary section as recited in claim 18, wherein the means is a plurality of elastic cords.

20. An auxiliary section as recited in claim 18, wherein the at least one auxiliary leg is two legs and the means is a plurality of hooks for coupling to the legs, first cords for coupling the tarp to the hooks and clamps for coupling second cords between the hooks and cords, each clamp

having opposing portions that form respective hollows for receiving the first and second cords, the hollows including ridges to increase a holding retention therein.

* * * * *