

No. 655,005.

Patented July 31, 1900.

S. L. PENFIELD.  
CONTACT GONIOMETER.

(Application filed Apr. 2, 1900.)

(No Model.)

2 Sheets—Sheet 1.

Fig. 1

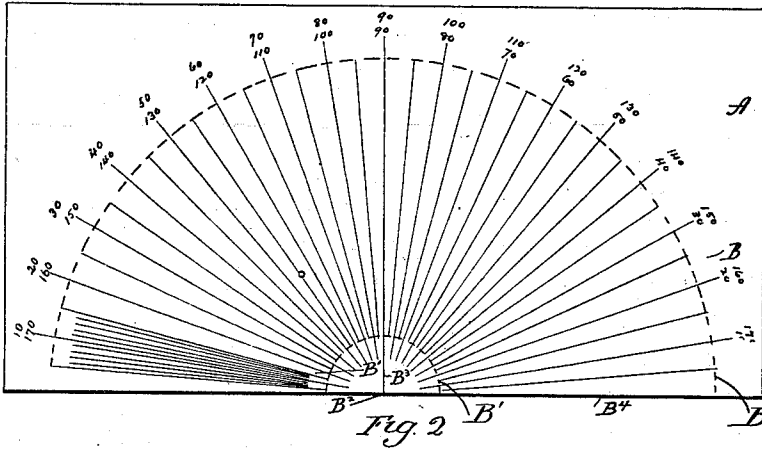

Fig. 2

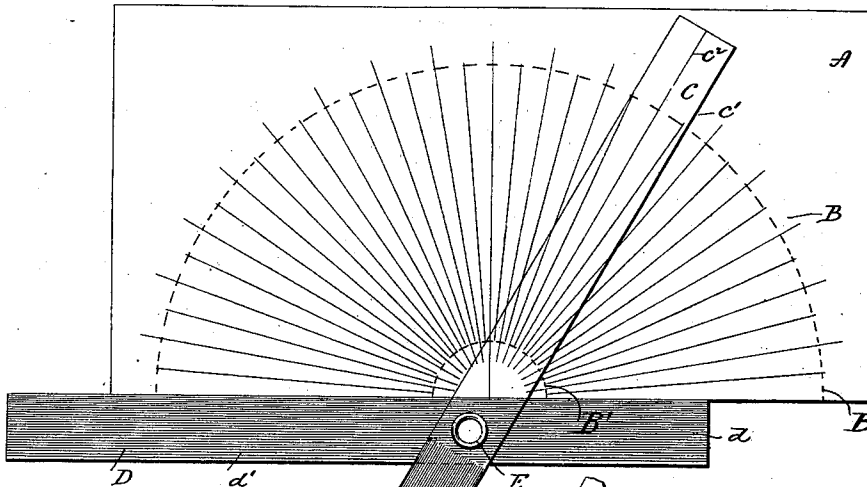
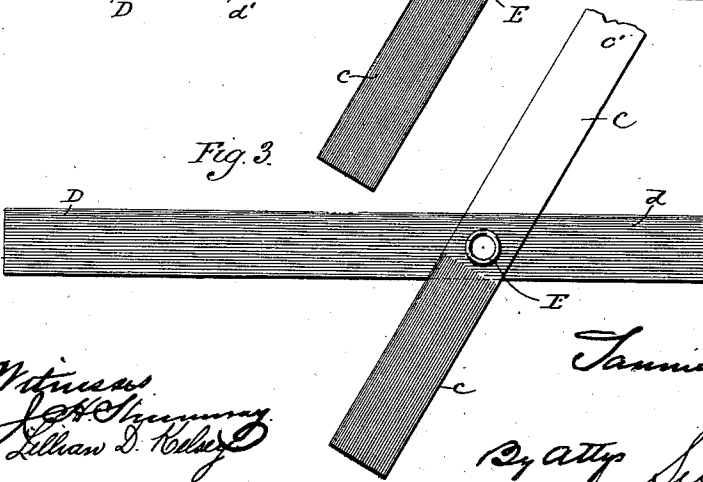

Fig. 3



Witnesses  
John H. ...  
William D. Kelly

Samuel Lewis Penfield  
Inventor  
By atty Seymour & Carce

No. 655,005.

Patented July 31, 1900.

S. L. PENFIELD.  
CONTACT GONIOMETER.

(Application filed Apr. 2, 1900.)

(No Model.)

2 Sheets—Sheet 2.

Fig 4

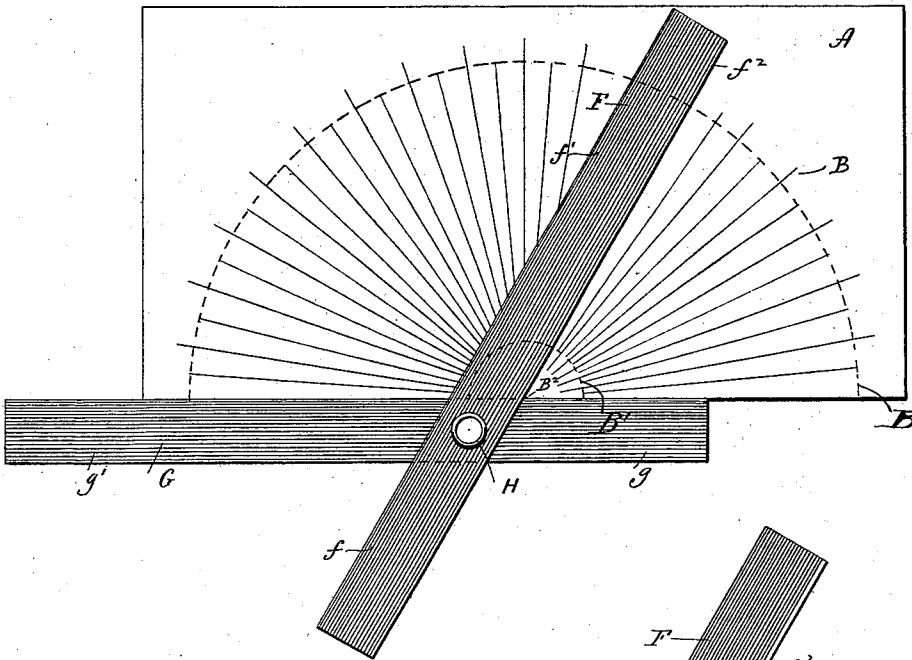
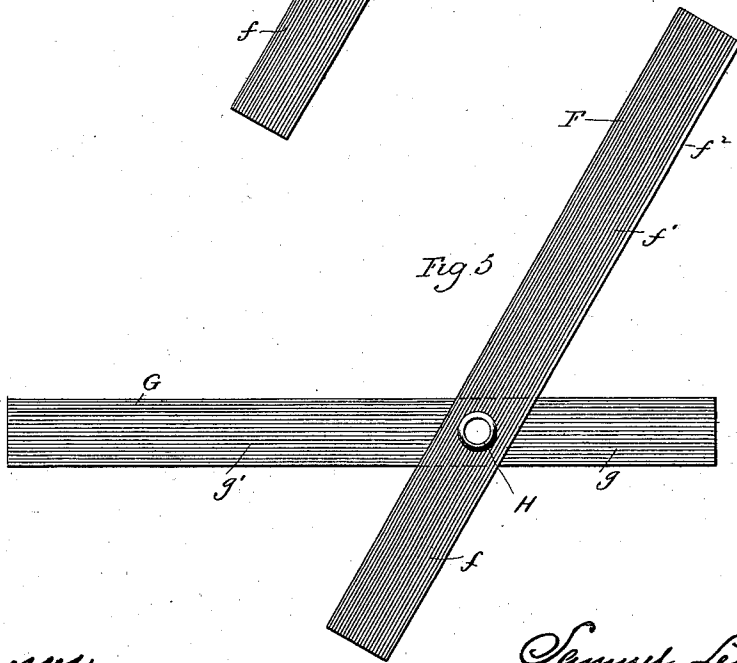

Fig 5



Witness  
J. H. Shumway  
William D. Kellogg

Samuel Lewis Penfield  
Inventor  
By Atty. Seymour & Carr

# UNITED STATES PATENT OFFICE.

SAMUEL LEWIS PENFIELD, OF NEW HAVEN, CONNECTICUT.

## CONTACT-GONIOMETER.

SPECIFICATION forming part of Letters Patent No. 655,005, dated July 31, 1900.

Application filed April 2, 1900. Serial No. 11,049. (No model.)

*To all whom it may concern:*

Be it known that I, SAMUEL LEWIS PENFIELD, of New Haven, in the county of New Haven and State of Connecticut, have invented a new Improvement in Contact-Goniometers; (Case B;) and I do hereby declare the following, when taken in connection with the accompanying drawings and the letters of reference marked thereon, to be a full, clear, and exact description of the same, and which said drawings constitute part of this specification, and represent, in—

Figure 1, a plan view of the card of my improved goniometer; Fig. 2, a plan view of the card, showing the swiveled measuring-arms applied to its base-line; Fig. 3, a detached plan view of the arms, one of which is partly broken away; Fig. 4, a view showing one of the modified forms which the swiveled measuring-arms may assume and illustrating the manner of applying them to the base-line of the card; Fig. 5, a detached plan view of the said modified arms.

My invention relates to an improvement in that class of instruments used in crystallography for measuring the interfacial angles of crystals and called "contact-goniometers" to distinguish them from reflection-goniometers, the object being to produce a simple, convenient, and accurate instrument constructed with particular reference to cheapness of production.

With these ends in view my invention consists in a contact-goniometer comprising a card provided with a divided semicircle and having a base-line, and two independently-organized or detached measuring-arms swiveled together between their indicating and their measuring ends and adapted to be applied to the base-line of the card, so that while the edge of one arm is in contact with that line the other arm will be brought into position upon the card to indicate, in conjunction with the degree-lines thereof, the angle measured by the measuring ends of the measuring-arms.

My invention further consists in certain details of construction, as will be hereinafter described, and pointed out in the claims.

In carrying out my invention, as shown in Figs. 1, 2, and 3, I employ a cardboard card A, provided with a divided semicircle B, the degree-lines of which are preferably extended inward to a small semicircle B', surrounding

the center B<sup>2</sup> of the circle, the said center being indicated by the extreme inner end of a line B<sup>3</sup>, placed at a right angle to the base-line B<sup>4</sup> of the card. The inward extensions of the degree-lines are stopped at the said semicircle B', because if it were practicable to draw them to a focus at the said point B<sup>2</sup>, representing the true center of the circle, they would appear to the unassisted eye to run together. The semicircles B and B', I have indicated by broken lines for convenience of illustration and because it is impossible to put on the drawings all of the degree-lines which themselves establish the two semicircles. There is no difficulty, of course, in engraving those lines; but for the purpose of a Patent Office drawing they cannot be drawn. With such a card I employ two independently-organized or detached measuring-arms C and D, swiveled together between their measuring ends *c* and *d* and their indicating ends *c'* and *d'* by an eyelet E, applied to the arms, so as to make their swiveling movement so stiff as never to take place unassisted by the user of the instrument. As shown, the arms C and D correspond to each other in length and width, though this is not imperative. They are swiveled together not at their longitudinal centers, but sufficiently at one side thereof to produce indicating ends long enough to reach from the base-line of the card to or beyond the outer edge of the divided semicircle B, where the numbers indicating the degrees are located. By preference the arm C is made from a strip of transparent celluloid, while the arm D is made from a corresponding strip of vulcanized or hard fiber. The indicating end *c'* of the transparent measuring-arm C is provided with a long indicating-line *c''*, placed in its longitudinal center in position to intersect the imaginary center of the eyelet E. The measuring end *c* of the said arm C, I preferably render opaque by coating its surface with a coat of paint or other opaque material. I do not, however, limit myself to making the arms C and D of the material named or of the precise form shown, though excellent results are obtained by making them exactly as shown and described.

In using my improved contact-goniometer the measuring ends *c* and *d* of the measuring-arms are brought into contact with the faces of the crystal and the plane of the arms kept

as nearly as possible at a right angle to the edge formed by the intersection of the faces. The measuring-arms are then removed from the crystal and applied to the card in such a manner that the inner edge of the opaque measuring-arm D will be in contact with the base-line of the card, upon which the said edge of the said arm is then shifted in one direction or the other until the inner end of the indicating-line  $c^2$  of the transparent indicating end  $c'$  of the measuring-arm C coincides with the point  $B^2$ , representing the center of the circle. The indicating-line  $c^2$  will now be found to be parallel or substantially parallel with one of the long degree-lines of the divided semicircle B. This degree-line, which will be seen through the transparent arm, will indicate by its position among its fellows the angle measured by the measuring ends of the arms. By reading in this way the measurements obtained from the indicating-line  $c^2$  through the transparent indicating-arm I am enabled to secure not only very accurate measurements, but to secure such measurements very quickly.

Instead of locating the indicating-line  $c^2$  in the center of the indicating end  $c'$  of the measuring-arm C the said line may be located on either side of the center of the said end of the said arm. It must, however, be parallel with one edge of the said end of the arm. It might even be dispensed with altogether and one edge of the said end of the arm used in its place to read from.

In the modified construction shown by Figs. 4 and 5 I employ a cardboard card corresponding to the card A; but instead of employing one opaque and one transparent measuring-arm I employ two independently-organized or detached opaque measuring-arms F and G, swiveled together by an eyelet H, located between their measuring ends  $f$  and  $g$  and their indicating ends  $f'$  and  $g'$ . In using these arms their measuring ends  $f$  and  $g$  are brought as nearly into contact with the faces of the crystal as may be and the plane of the arms kept as nearly as possible at a right angle to the edge formed by the intersection of the said faces. The swiveled arms are then applied to the card, so that the point of divergence of the adjacent edges of the indicating ends  $f'$  and  $g'$  of the arms will exactly coincide with the point  $B^2$ , representing the center of the divided semicircle B of the card, as shown in Fig. 4. At this time the inner edge of the arm G should exactly coincide with the base-line of the card. The edge  $f^2$  of the arm F will now be parallel or substantially parallel with one of the long degree-lines of the divided semicircle, and that line will by its position therein indicate the interfacial angle of the crystal measured by the measuring ends of the arms. If necessary, the measuring ends of the arms may be snipped off to adapt them to be applied to the crystal, depending upon the size and position thereof. My purpose is to provide each goniometer with

one or more pairs of these hard-fiber arms, so that some can be snipped, as described, and some kept in their original form.

In view of the modifications suggested and of others which may obviously be made I would have it understood that I do not limit myself to the exact construction herein shown and described, but hold myself at liberty to make such changes as fairly fall within the spirit and scope of my invention.

Having fully described my invention, what I claim as new, and desire to secure by Letters Patent, is—

1. A contact-goniometer comprising a card provided with a divided semicircle having a base-line, and two independently-organized or detached measuring-arms swiveled together between their indicating ends and their measuring ends, and one of them being made of a transparent material through which the divisions of the said semicircle may be read, the said arms being adapted to be temporarily applied to the base-line of the card so that while the edge of one arm is in contact with the said base-line, the other arm will be brought into position upon the card to indicate in conjunction with the degree-lines thereof, the angle measured by the measuring ends of the arms.

2. A contact-goniometer, comprising a card provided with a divided semicircle and having a base-line, and two independently-organized or detached measuring-arms swiveled together between their indicating ends and their measuring ends, and one of them having a transparent indicating end through which the divisions of the said semicircle may be read, the said arms being adapted to be temporarily applied to the base-line of the card, so that while the edges of one arm are in contact with the said base-line, the other arm will be brought into position upon the card to indicate in conjunction with the degree-lines thereof, the angles measured by the measuring ends of the arms.

3. A contact-goniometer, comprising a card provided with a divided semicircle and having a base-line, and two independently-organized or detached measuring-arms swiveled together between their indicating ends and their measuring ends, and made of readily-divisible material to adapt them to be cut off to meet the requirements of use, and adapted to be temporarily applied to the base-line of the card, so that while the edge of one arm is in contact with that base-line the other arm will be brought into position upon the card to indicate in conjunction with the degree-lines thereof, the angles measured by the measuring ends of the arms.

In testimony whereof I have signed this specification in the presence of two subscribing witnesses.

SAMUEL LEWIS PENFIELD.

Witnesses:

FRED. C. EARLE,

GEORGE D. SEYMOUR.