



- (51) **International Patent Classification:**
A61M 25/00 (2006.01) A61F 2/01 (2006.01)
- (21) **International Application Number:**
PCT/US2016/014763
- (22) **International Filing Date:**
25 January 2016 (25.01.2016)
- (25) **Filing Language:** English
- (26) **Publication Language:** English
- (30) **Priority Data:**

62/107,216	23 January 2015 (23.01.2015)	US
62/107,449	25 January 2015 (25.01.2015)	US
62/109,388	29 January 2015 (29.01.2015)	US
- (71) **Applicant:** CONTEGO MEDICAL LLC [US/US]; Suite 102, 3921 Sunset Ridge Road, Raleigh, North Carolina 27607 (US).
- (72) **Inventors:** SACHAR, Ravish; 4204 Berry D. Sims Wynd, Raleigh, North Carolina 27612 (US). PATEL, Udayan G.; 6508 Deer Hollow Drive, San Jose, California 95120 (US).
- (74) **Agents:** SMITH, Amanda et al.; Meunier Carlin & Curfman LLC, Suite 1300, 999 Peachtree Street NE, Atlanta, Georgia 30309 (US).
- (81) **Designated States** (unless otherwise indicated, for every kind of national protection available): AE, AG, AL, AM, AO, AT, AU, AZ, BA, BB, BG, BH, BN, BR, BW, BY, BZ, CA, CH, CL, CN, CO, CR, CU, CZ, DE, DK, DM,

DO, DZ, EC, EE, EG, ES, FI, GB, GD, GE, GH, GM, GT, HN, HR, HU, ID, IL, IN, IR, IS, JP, KE, KG, KN, KP, KR, KZ, LA, LC, LK, LR, LS, LU, LY, MA, MD, ME, MG, MK, MN, MW, MX, MY, MZ, NA, NG, NI, NO, NZ, OM, PA, PE, PG, PH, PL, PT, QA, RO, RS, RU, RW, SA, SC, SD, SE, SG, SK, SL, SM, ST, SV, SY, TH, TJ, TM, TN, TR, TT, TZ, UA, UG, US, UZ, VC, VN, ZA, ZM, ZW.

(84) **Designated States** (unless otherwise indicated, for every kind of regional protection available): ARIPO (BW, GH, GM, KE, LR, LS, MW, MZ, NA, RW, SD, SL, ST, SZ, TZ, UG, ZM, ZW), Eurasian (AM, AZ, BY, KG, KZ, RU, TJ, TM), European (AL, AT, BE, BG, CH, CY, CZ, DE, DK, EE, ES, FI, FR, GB, GR, HR, HU, IE, IS, IT, LT, LU, LV, MC, MK, MT, NL, NO, PL, PT, RO, RS, SE, SI, SK, SM, TR), OAPI (BF, BJ, CF, CG, CI, CM, GA, GN, GQ, GW, KM, ML, MR, NE, SN, TD, TG).

Declarations under Rule 4.17:

- as to applicant's entitlement to apply for and be granted a patent (Rule 4.17(ii))
- as to the applicant's entitlement to claim the priority of the earlier application (Rule 4.17(iii))

Published:

- with international search report (Art. 21(3))
- before the expiration of the time limit for amending the claims and to be republished in the event of receipt of amendments (Rule 48.2(h))

(54) **Title:** INTERVENTIONAL DEVICE HAVING AN INTEGRATED EMBOLIC FILTER AND ASSOCIATED METHODS

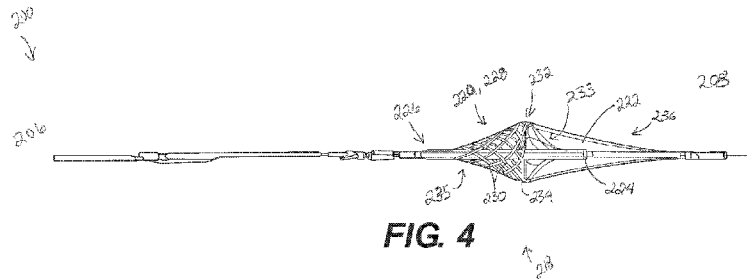
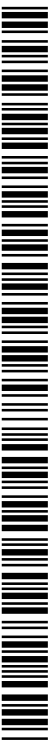

FIG. 4

(57) **Abstract:** A percutaneous transluminal device, comprising an elongated catheter, an interventional device operably coupled to the proximal end of the catheter, a filter operably coupled to the distal end of the catheter, the filter movable between a collapsed and deployed position 218, and an actuator wire for deploying the collapsing the filter. The filter including a filter chassis comprising a movable collar a fixed collar and a tubular braided scaffolding coupled between the movable collar and the fixed collar. Each wire of the braided scaffolding moving independently with respect to the other wires between the movable collar and the fixed collar as the filter moves between the collapsed position and the deployed position.



INTERVENTIONAL DEVICE HAVING AN INTEGRATED EMBOLIC FILTER AND ASSOCIATED METHODS

Related Applications

[0001] This application claims the benefit of U.S. Provisional Application 62/107,216, filed January 23, 2015, U.S. Provisional Application 62/107,449, filed January 25, 2015, and U.S. Provisional Application 62/109,388, filed January 29, 2015. Each of these applications are incorporated by reference in their entireties for all purposes.

BACKGROUND OF THE INVENTION

Field of the Invention

[0002] This invention relates generally to interventional devices and, more particularly, to interventional devices having an integrated embolic filter, as well as methods of making and using the same.

Description of the Related Art

[0003] The vascular bed supplies a constant flow of oxygen-rich blood to the organs. In diseased vessels, blockages can develop that can reduce blood flow to the organs and cause adverse clinical symptoms up to and including fatality. Diseased vessels can comprise a range of material from early-stage thrombosis to late-stage calcified plaque.

[0004] Angioplasty can be described as a catheter-based procedure performed by a physician to open up a stenosed vessel and restore blood flow. An entry site can be opened, for example, in the patient's groin, arm, or hand, and a guide wire and catheter can be advanced under fluoroscopic guidance to the location of the blockage. A catheter having a small balloon adjacent its distal end can be advanced under fluoroscopic guidance until the balloon lies within the stenosed region. The balloon can be then inflated and deflated one or more times to expand the stenosed region of the artery.

[0005] Angioplasty is one example of a vascular intervention that can release embolic particles down-stream from a stenosed or otherwise compromised location during intervention. These embolic particles can result in adverse clinical consequences. It has been shown beneficial to trap these embolic particles to prevent them from traveling downstream with blood flow to the capillary bed (e.g., Baim D S, Wahr D, George B, et al., Randomized trial of a distal embolic

protection device during percutaneous intervention of saphenous vein aorta-coronary bypass grafts, *Circulation* 2002; 105:1285-90).

[0006] In addition to balloon angioplasty, stenoses can also be treated with stents and with mechanical thrombectomy devices. These devices are also prone to releasing embolic particles downstream from a stenosed location during intervention.

[0007] Systems available today used to catch these embolic particles consist primarily of distal filter systems or occlusion balloon systems. Distal filter systems are on guidewires, as are distal balloon occlusion systems. Proximal balloon occlusion systems are on a guide catheter or sheath. These systems suffer shortcomings related to simplicity of use. Embolic protection guidewires also suffer from flexibility and stability problems that render the protected angioplasty procedure relatively more difficult in many cases. In the case of saphenous vein grafts, the problems relate specifically to aorto-ostial lesions, where the guidewire may not be long enough to provide support, or distal vein graft lesions, where there can be not enough of a landing zone for the filter. The latter can be a problem as currently available filter systems can have a considerable distance between the treatment balloon and the distal filter. This distance can be a problem not only in distal vein graft lesions, but also in arterial stenoses in which there can be a side branch immediately after the stenosis. In such cases, the filter can often be deployed only distal to the side branch, thus leaving the side branch unprotected from embolic particles.

[0008] Accordingly, a need exists for improved interventional devices having an integrated embolic filter as well as methods for making and using the same.

SUMMARY

[0009] It is to be understood that this summary is not an extensive overview of the disclosure. This summary is exemplary and not restrictive, and it is intended to neither identify key or critical elements of the disclosure nor delineate the scope thereof. The sole purpose of this summary is to explain and exemplify certain concepts of the disclosure as an introduction to the following complete and extensive detailed description.

[0010] In one aspect, the present disclosure describes a percutaneous transluminal device comprising an elongated catheter having a longitudinal axis, a proximal end portion, a distal end portion, and an outer side wall; an interventional device operably coupled to the distal end portion of the catheter; and a filter operably coupled to the distal end portion of the catheter, wherein the filter can be selectively collapsible and expandable about and between a collapsed position and a deployed position. In one aspect, the filter can comprise a filter chassis operably

coupled to a filter membrane. The filter chassis can comprise a movable collar slidably coupled to the catheter, a fixed collar spaced from the movable collar relative to the longitudinal axis of the catheter and immovably coupled to the catheter, and a tubular braided scaffolding comprising a plurality of wires and having a first end coupled to the movable collar and an opposed second end coupled to the fixed collar, wherein each wire of the plurality of wires extends between the first and second ends of the braided scaffolding, wherein each wire of the plurality of wires moves independently, or, alternatively, slides independently, with respect to the other wires between the movable collar and the fixed collar as the filter moves between the collapsed position and the deployed position. In another aspect, each wire of the plurality of wires can further comprise at least one crossover portion and at least one non-crossover portion and, in a further aspect, the filter membrane can be selectively attached to a plurality of the non-crossover portions. In another aspect, the catheter further comprises a lumen and a port in communication with the lumen, the port comprising an aperture in the outer side wall of the catheter located in between the fixed collar and the movable collar, and the lumen extending from the proximal end portion of the catheter to the port. It is contemplated that the device further comprises an actuator wire having a proximal and distal ends, wherein at least a portion of the actuator wire extends through the lumen of the catheter, and wherein the distal end of the actuator wire exits the lumen of the catheter through the port and is coupled to the movable collar. In one aspect, when the filter is in the collapsed position, pulling on the proximal end of the actuator wire exerts a force on the movable collar in a direction relative to the longitudinal axis of the catheter that moves the movable collar toward the fixed collar and wherein selective movement of the movable collar towards the fixed collar causes a central portion of the filter chassis to radially expand thereby selectively expanding the filter toward the deployed position.

[0011] In another aspect, the present disclosure describes a percutaneous transluminal device comprising an elongated catheter having a longitudinal axis, a proximal end portion, a distal end portion, and an outer side wall, an interventional device operably coupled to the distal end portion of the catheter, and a filter operably coupled to the distal end portion of the catheter, wherein the filter can be selectively collapsible and expandable about and between a collapsed position and a deployed position. In one aspect, the filter can comprise a filter chassis comprising a tubular braided scaffolding having a distal end coupled to a movable collar that is slidably coupled to the catheter and having a proximal end that is coupled to a fixed collar that is spaced from the movable collar relative to the catheter longitudinal axis and immovably coupled to the catheter. In another aspect, the braided scaffolding can have a shape memory that urges

the filter into the collapsed position. It is further contemplated that the braided scaffolding can have a central portion having a maximal radial displacement from the catheter longitudinal axis, or apex that is greater than a target vessel radius when the filter is in the deployed position. In another aspect, the catheter can further comprise a lumen and a port in communication with the lumen, the port comprising an aperture in the outer side wall of the catheter located in between the fixed collar and the movable collar, and the lumen extending from the proximal end portion of the catheter to the port. It is contemplated that the device can further comprise an actuator wire having a proximal and distal ends, wherein at least a portion of the actuator wire extends through the lumen of the catheter, and wherein the distal end of the actuator wire exits the lumen of the catheter through the port and can be coupled to the movable collar. In one aspect, when the filter is in the collapsed position, pulling on the proximal end of the actuator wire exerts a force on the movable collar in a direction relative to the longitudinal axis of the catheter that moves the movable collar toward the fixed collar. It is contemplated that selective movement of the movable collar towards the fixed collar causes the filter to selectively expand, thereby allowing the filter to conformably appose an inner wall of the target vessel and, in the selectively expanded configuration, the filter captures substantially 100% of embolic particles having a particle size of at least 150 microns while remaining substantially patent during operation of the angioplasty treatment device and at least until the filter is collapsed for removal of the angioplasty device from the vessel.

[0012] Additional features and advantages of exemplary implementations of the invention will be set forth in the description which follows, and in part will be obvious from the description, or may be learned by the practice of such exemplary implementations. The features and advantages of such implementations may be realized and obtained by means of the instruments and combinations particularly pointed out in the appended claims. These and other features will become more fully apparent from the following description and appended claims, or may be learned by the practice of such exemplary implementations as set forth hereinafter.

BRIEF DESCRIPTION OF THE DRAWINGS

[0013] The accompanying drawings, which are incorporated in and constitute a part of this specification, illustrate aspects and together with the description, serve to explain the principles of the methods and systems.

- [0014] Fig. 1 provides a side view of an example percutaneous transluminal device illustrating the filter in a collapsed position;
- [0015] Fig. 2 provides a side view of the percutaneous transluminal device of Fig. 1 illustrating the filter in a deployed position;
- [0016] Fig. 3 provides a side view of an example percutaneous transluminal device illustrating the filter in a collapsed position;
- [0017] Fig. 4 provides a side view of the percutaneous transluminal device of Fig. 3 illustrating the filter in a deployed position;
- [0018] Fig. 5 provides a side view of the percutaneous transluminal device of Fig. 3 illustrating the filter and the interventional device in deployed positions;
- [0019] Fig. 6 provides a partial perspective view of the percutaneous transluminal device and deployed filter of Fig. 3;
- [0020] Fig. 7 provides two partial side views of the percutaneous transluminal device and deployed filter of Fig. 3 with varied braid configurations;
- [0021] Fig. 8A provides a partial view of an example tubular braided scaffolding;
- [0022] Fig. 8B provides a partial view of an example tubular braided scaffolding;
- [0023] Fig. 9 provides a partial view of an example tubular braided scaffolding;
- [0024] Fig. 10 provides a partial view of an example filter membrane;
- [0025] Fig. 11 provides a left side view of an example handle of a percutaneous transluminal device;
- [0026] Fig. 12 provides a right side perspective view of the handle of Fig. 11;
- [0027] Fig. 13 provides a left side perspective view of the handle of Fig. 11;
- [0028] Fig. 14 provides a right side partial section view of the handle of Fig. 11;

[0029] Fig. 15 provides a right side section view of the handle of Fig. 11;

[0030] Fig. 16 provides from top left corner clockwise: the collapsed filter is shown in its initial state. The next figure shows the filter is deployed in an arterial model. The third figure shows the filter has captured particles. The last figure shows the filter is now collapsed trapping the particles within the filter membrane;

[0031] Fig. 17 provides a table of Membrane Particulate Capture Efficiency Test Results;

[0032] Fig. 18 provides the deployed filter inside an arterial model;

[0033] Fig. 19 provides the collapsed filter in a curvature;

[0034] Fig. 20 provides an example percutaneous transluminal device.

DESCRIPTION OF THE INVENTION

[0035] The present invention can be understood more readily by reference to the following detailed description, examples, drawing, and claims, and their previous and following description. However, before the present devices, systems, and/or methods are disclosed and described, it is to be understood that this invention is not limited to the specific devices, systems, and/or methods disclosed unless otherwise specified, as such can, of course, vary. It is also to be understood that the terminology used herein is for the purpose of describing particular aspects only and is not intended to be limiting.

[0036] The following description of the invention is provided as an enabling teaching of the invention in its best, currently known aspect. To this end, those skilled in the relevant art will recognize and appreciate that many changes can be made to the various aspects of the invention described herein, while still obtaining the beneficial results described herein. It will also be apparent that some of the desired benefits described herein can be obtained by selecting some of the features described herein without utilizing other features. Accordingly, those who work in the art will recognize that many modifications and adaptations to the present invention are possible and can even be desirable in certain circumstances and are a part described herein. Thus, the following description is provided as illustrative of the principles described herein and not in limitation thereof.

[0037] Reference will be made to the drawings to describe various aspects of one or more implementations of the invention. It is to be understood that the drawings are diagrammatic and schematic representations of one or more implementations, and are not limiting of the present disclosure. Moreover, while various drawings are provided at a scale that is considered functional for one or more implementations, the drawings are not necessarily drawn to scale for all contemplated implementations. The drawings thus represent an exemplary scale, but no inference should be drawn from the drawings as to any required scale.

[0038] In the following description, numerous specific details are set forth in order to provide a thorough understanding described herein. It will be obvious, however, to one skilled in the art that the present disclosure may be practiced without these specific details. In other instances, well-known aspects of vascular intervention and vascular interventional devices have not been described in particular detail in order to avoid unnecessarily obscuring aspects of the disclosed implementations.

[0039] As used in the specification and the appended claims, the singular forms “a,” “an” and “the” include plural referents unless the context clearly dictates otherwise. Ranges may be expressed herein as from “about” one particular value, and/or to “about” another particular value. When such a range is expressed, another aspect includes from the one particular value and/or to the other particular value. Similarly, when values are expressed as approximations, by use of the antecedent “about,” it will be understood that the particular value forms another aspect. It will be further understood that the endpoints of each of the ranges are significant both in relation to the other endpoint, and independently of the other endpoint.

[0040] “Optional” or “optionally” means that the subsequently described event or circumstance may or may not occur, and that the description includes instances where said event or circumstance occurs and instances where it does not.

[0041] Throughout the description and claims of this specification, the word “comprise” and variations of the word, such as “comprising” and “comprises,” means “including but not limited to,” and is not intended to exclude, for example, other additives, components, integers or steps. “Exemplary” means “an example of” and is not intended to convey an indication of a preferred or ideal aspect. “Such as” is not used in a restrictive sense, but for explanatory purposes.

[0042] Disclosed are components that can be used to perform the disclosed methods and systems. These and other components are disclosed herein, and it is understood that when combinations, subsets, interactions, groups, etc. of these components are disclosed that while specific reference of each various individual and collective combinations and permutation of these may not be explicitly disclosed, each is specifically contemplated and described herein, for all methods and systems. This applies to all aspects of this application including, but not limited to, steps in disclosed methods. Thus, if there are a variety of additional steps that can be perdefined it is understood that each of these additional steps can be perdefined with any specific aspect or combination of aspects of the disclosed methods.

[0043] Implementations described herein and depicted in Figures 1-15 provide for a percutaneous transluminal catheter-based device comprising an interventional device and having an integrated filter. The integrated filter comprises a flexible and conformable braided filter chassis that enables the filter to conform to any vessel shape. Additionally, the integrated filter can be configured to selectively move about and between a collapsed position and a deployed position. In another aspect, the unconstrained diameter of the filter in the deployed position can be greater than the target vessel. Accordingly, the integrated filter can be selectively deployed to conformably oppose the vessel wall and create a zone of apposition between the filter and the vessel wall. The devices described herein enable many other advantages over prior art devices, such as improved flexibility, a lower profile, no buckling even in the most tortuous vascular segments, improved traction through bends and pre-existing stents in steep angles, atraumatic deployment, 100% embolic capture efficiency, and complete collapse to facilitate ease and predictability of removal. These features and advantages, along with other features and advantages, will be discussed in detail herein.

[0044] In another aspect, the interventional device 212 can be an angioplasty interventional device such as, for example and without limitation, an angioplasty balloon, a stent, a mechanical thrombectomy device, an atherectomy device and the like. In a further aspect, the atherectomy device can comprise a rotational atherectomy device, a directional atherectomy device or a combination thereof. In other aspects, the interventional device can be selected to effect valvuloplasty, ablation, or the like.

[0045] In one aspect illustrated in Figures 1-7, the present disclosure describes a percutaneous transluminal device 200 comprising an elongated catheter 202 having a longitudinal axis 204, a proximal end portion 206, a distal end portion 208, and an outer side

wall 210; an interventional device 212 operably coupled to the proximal end portion 206 of the catheter 202, and a filter 214 operably coupled to the distal end portion 208 of the catheter 202, wherein the filter 214 can be selectively collapsible and expandable about and between a collapsed position 216 and a deployed position 218. An exemplary interventional device is shown in a deployed position in Figure 5. In light of the present disclosure, one skilled in the art will appreciate that the interventional device 212 can be located either proximal or distal to the filter 214 relative to the longitudinal axis 204 of the catheter 202 depending on the particulars of the intervention for which the percutaneous transluminal device 200 is configured to effect. Similarly, one skilled in the art will understand that the filter 214 should be oriented appropriately and located downstream from the interventional device 212 relative to the blood flow depending on the same. Solely for clarity of disclosure, the specific case of angioplasty and a treatment device comprising a filter located distal to the treatment device is described and discussed herein; accordingly, neither of these features should be construed as limiting aspects of this disclosure.

[0046] In another aspect, the filter 214 can comprise a filter chassis 220 and a filter membrane 222 operably coupled to the filter chassis 220. In one aspect, the filter chassis 220 can comprise a movable collar 224 slidably coupled to the catheter 202, a fixed collar 226 spaced from the movable collar 224 relative to the longitudinal axis 204 of the catheter 202 and immovably coupled to the catheter 202, and a tubular braided scaffolding 228 comprising a plurality of wires 230 and having a first end 233 coupled to the movable collar 224 and an opposed second end 235 coupled to the fixed collar 226. It is contemplated that each wire of the plurality of wires 230 of the tubular braided scaffolding 228 extends between the first and second ends of the braided scaffolding 228. In another aspect, each wire of the plurality of wires moves independently, or, alternatively, slides independently, with respect to the other wires between the movable collar and the fixed collar as the filter moves between the collapsed position 216 and the deployed position 218. In operation, as the distance between the movable collar 224 and the fixed collar 226 along the catheter longitudinal axis 204 is selectively decreased, a central portion 232 of the tubular braided scaffolding 228 will radially expand, causing the filter 214 to selectively expand towards the deployed position 218 and conformably appose an inner wall of the target vessel thus achieving atraumatic filter deployment. As one skilled in the art will appreciate in light of the present disclosure, the filter chassis 220 described herein enables the filter 214 to conform to the shape of the vessel and, when the at least partially deployed filter radius 234 is greater than the target vessel radius, conformably appose the vessel wall over a

length referred to herein as a "zone of apposition" thereby increasing the capture efficiency of the deployed filter. Additionally, one skilled in the art will appreciate in light of the present disclosure that the filter chassis 220 described herein can collapse completely against the catheter side wall when the filter 214 is returned to the collapsed position 216 and, also, will not buckle regardless of vessel tortuosity.

[0047] In another aspect, the plurality of wires 230 comprises from about 12 to about 64 wires, more particularly, from about 12 to about 32 wires, and, most particularly, about 16 wires.

[0048] In another aspect, each of the plurality of wires 230 can be formed from a shape memory material. It is contemplated that the shape memory material can be, for example and without limitation, nitinol or any other shape memory material known in the art. In a further aspect, the braided scaffolding 228 can have a shape memory corresponding to the collapsed position 216 of the filter 214. Here, in operation, the braided scaffolding 228 having a normally collapsed shape memory urges the filter into the collapsed position absent application of a sufficient opposing force.

[0049] In another aspect, each wire of the plurality of wires 230 can be formed from a non-shape memory material, for example and without limitation, a cobalt chromium alloy, a stainless steel alloy, a molybdenum rhenium alloy, a plastic, and the like. In yet another aspect, some of the plurality of wires 230 can be formed from a shape memory material and the remainder of the plurality of wires can be formed from a non-shape memory material.

[0050] In another aspect, at least one of the plurality of wires 230 comprises a substantially round cross-section. In a further aspect, the round cross-section can range from about 60 to about 120 microns in diameter, more particularly, can be about 100 microns in diameter. In another aspect, at least one of the plurality of wires comprises a substantially rectangular cross-section. In a further aspect, the rectangular cross-section can have at least one of a height and a width of from about 60 to about 150 microns.

[0051] In yet another aspect illustrated in Figures 8A and 8B, the braided scaffolding 228 can be further characterized by the number of wire cross-overs 500a and 500b per inch along the length of each wire of the plurality of wires, hereinafter referred to as "picks per inch." It is contemplated that the braided scaffolding can have from about 6 to about 20 picks per inch, more preferably from about 7 to about 12 picks per inch, and, most preferably, about 9 picks per inch.

[0052] In yet another aspect, the braided scaffolding can be further characterized by the pattern of relative "over" or "under" placement of the wire cross-overs along the length of each of the plurality of wires. In one exemplary aspect illustrated in Figure 8A, the braided scaffolding comprises a one-on-one configuration, meaning that the wire cross-overs along each of the plurality of wires alternate between one other wire crossing over 500a and one other wire crossing under 500b each wire. In another exemplary aspect illustrated in Figure 8B, the braided scaffolding comprises a one-on-two configuration, meaning that the wire cross-overs along each of the plurality of wires has a pattern where two other wires cross over and one other wire crosses under each wire or vice-versa. Figure 7 shows two different braided configurations with variations on the placement of the over versus under wires.

[0053] In another aspect illustrated in Figure 9, each wire 600 of the plurality of wires 230 can further comprise at least one crossover portion 602 and at least one non-crossover portion 604. Here, a crossover portion 602 of a wire slidably contacts another wire of the plurality of wires 230 as the filter 214 moves between and about the collapsed position 216 to the deployed position 218. Correspondingly, a non-crossover portion 604 of a wire 600 does not contact any of the other wires of the plurality of wires 230 as the filter 214 moves between and about the collapsed position 216 and the deployed position 218. In a further aspect, the filter membrane 222 can be selectively attached to a plurality of the non-crossover portions 604 of the plurality of wires 230 of the braided scaffolding 228. In operation, selective attachment of the filter membrane 222 to a plurality of the non-crossover portions 604 of the plurality of wires 230 of the braided scaffolding 220 ensures the filter chassis 220 can open uniformly and to its full deployed position.

[0054] Referring to Figures 1-7 and also to Figure 9, in another aspect, the filter chassis 220 has a central portion 232 having a maximum radial displacement, or apex 234 from the collapsed position 216 when the filter 214 is unconstrained and in the deployed position 218. It is contemplated that the filter membrane 222 can be selectively attached to the filter chassis 220 at a plurality of non-crossover portions 604 of the plurality of wires 230 of the braided scaffolding 228 located on or adjacent to the exterior of the apex 234 of the central portion 232 of the filter chassis 220.

[0055] Referring to Figures 1-7, another aspect, the filter membrane 222 can extend beyond the filter chassis 220 in a longitudinal direction relative to the longitudinal axis of the catheter

such that a sac 236 is formed to retain embolic particles when the filter is in the collapsed position.

[0056] It is contemplated that the filter membrane 222 can comprise a polymer. In one aspect, the filter membrane 222 can be formed from polyurethane. In one aspect, the filter membrane 222 can be attached by thermal means, adhesive or by any other suitable attachment means known in the art.

[0057] As illustrated in Figure 10, it is also contemplated that the filter membrane 222 can comprise a braided mesh 700 operably coupled to the filter chassis 220. In one aspect, the braided mesh 700 is disposed on an interior surface 702 of the filter chassis 220. In another aspect, the braided mesh 700 comprises about 64 wires. In another aspect, the braided mesh 700 comprises N wires and is folded over to form an apparent mesh having 2N wires. In one exemplary aspect where the braided mesh 700 comprises about 64 wires, the apparent braided mesh comprises about 128 wires. In another aspect, the braided mesh 700 comprises a shape memory material. In a further aspect, the shape memory material of the braided mesh 700 corresponds to the deployed position of the filter 214 and the braided scaffolding 228 comprises shape memory material having a shape memory corresponding to the collapsed position of the filter 214. It is contemplated that such a filter can be particularly useful in relatively large vessels such as, for example and without limitation, the aorta. It is also contemplated that such a filter can open to diameters of up to about 50mm. In operation, the filter mesh 700 acts as a spring to aid in the selective expansion of the filter 214.

[0058] In another aspect, the filter membrane 222 comprises from about a 40 to about a 100 micron mesh, and more particularly from about a 40 to about a 60 micron mesh, and, most particularly, from about a 50 micron mesh. It is further contemplated that the filter membrane 222 can have a tolerance of about 10 microns.

[0059] It is further contemplated that at least one of the movable collar 224 and the fixed collar 226 can comprise a polymer. In a further aspect, the polymer can comprise polyimide. In an even further aspect, an interior surface of the movable collar 224 further comprises a coating having a lower coefficient of friction than the movable collar material and, even further, the coating can comprise, for example and without limitation, PTFE and the like.

[0060] In another aspect, that the distal portion 238 of the movable collar 224 can have a tapered portion that narrows toward the distal-most end of the movable collar 224.

[0061] In a further aspect, the movable collar 224 can be located distal to the fixed collar 226 relative to the longitudinal axis of the catheter 202.

[0062] In another aspect, the catheter 202 can further comprise a lumen 240 and a port 242 in communication with the lumen, the port comprising an aperture 211 in the outer side wall 210 of the catheter 202 located in between the fixed collar 226 and the movable collar 224, and the lumen extending from the proximal end portion 206 of the catheter to the port 242.

[0063] It is contemplated that the device 200 further comprises an actuator wire 246 having a proximal end 248 and a distal end 250, wherein at least a portion of the actuator wire extends through the lumen of the catheter 202, and wherein the distal end of the actuator wire exits the lumen of the catheter through the port and is coupled to the movable collar 224.

[0064] In one operational aspect, when the filter 214 is in the collapsed position 216, pulling on the proximal end 248 of the actuator wire 246 exerts a force on the movable collar 224 in a direction relative to the longitudinal axis 204 of the catheter 202 that moves the movable collar 224 toward the fixed collar 226 and wherein selective movement of the movable collar 224 towards the fixed collar 226 causes a central portion 232 of the filter chassis 220 to radially expand thereby selectively expanding the filter 214 towards the deployed position 218.

[0065] In one aspect illustrated in Figures 11-15, the percutaneous transluminal device 200 comprises a handle 800 coupled to the proximal end of the proximal end portion 206 of the catheter 202 and operably coupled to the proximal end of the actuator wire 246. The handle has a longitudinal axis 802 that can be coextensive with the catheter longitudinal axis. As shown in Figures 14-15, the handle can further comprise a screw 804 having at least one thread 806 disposed on an exterior surface 808 thereof, wherein the screw 804 can be coupled to the actuator wire 246; a handle body 810 having a distal portion 812 and a proximal portion 814; and an actuator 816 coupled to the screw 804 and operably coupled to the handle body 810. It is contemplated that the actuator 816 can be configured to effect axial displacement of the screw 804, and, correspondingly, the actuator wire 246, relative to the handle longitudinal axis 802. In one aspect, the actuator 816 can be a knob and the knob can be rotatably coupled to the screw 804 along the longitudinal axis 802 of the handle 800.

[0066] In another aspect, each of the distal portion 812 and a proximal portion 814 of the handle body 810 can have respective inner surfaces that cooperate to define a respective chamber 818, 820. In one aspect, the proximal portion 814 of the handle 800 can further comprise a distal stop 822, a proximal stop 824, and a plurality of thread-receiving members 826 for engaging the at least one thread 806 of the screw disposed on an inner surface thereof and positioned between the distal and proximal stops 822, 824 relative to the handle longitudinal axis 802. It is contemplated that the distal stop 822 can limit distal axial movement of the screw 804 and the proximal stop 824 can limit proximal axial movement of the screw 804.

[0067] In another aspect, the knob can be positioned between the distal portion 812 and the proximal portion 814 of the handle body 810. Here, it is contemplated that the proximal portion 814 and the distal portion 812 of the handle 800 are spaced apart along the handle longitudinal axis 802 and the handle 800 further comprises at least one bridge portion 828 extending between and connected to the proximal portion 814 and the distal portion 812; wherein the proximal portion 814, distal portion 812 and the bridge portion 828 cooperate to define an opening for receiving at least a portion of the knob. In one aspect, the knob can have a hole extending through the rotational axis of the knob and can further comprise a distal portion 830, a central portion 832, and a proximal portion 834. In one aspect, the distal portion 812 of the handle 800 can have a proximal end 836 configured to receive at least a portion of the distal portion 830 of the knob. It is contemplated that the distal portion 830 of the knob can be positioned in at least one of slidable and rotatable engagement with the proximal end 836 of the distal portion 812 of the handle body 810. In another aspect, the proximal portion 814 of the handle body 810 has a distal end 838 configured to receive a proximal portion 834 of the knob. Here, it is contemplated that the proximal portion 834 of the knob can be positioned in at least one of slidable and rotatable engagement with the distal end 838 of the proximal portion 814 of the handle body 810.

[0068] In another aspect, the inner surface of the distal end 838 of the proximal portion 814 of the handle body 810 is inwardly tapered relative to the handle longitudinal axis 802 from the distal end 838 to the distal stop 822. It is further contemplated that the proximal portion 834 of the knob further comprises an O-ring 840 fixed to the outer surface thereof. Here, it is further contemplated that the knob can also be slidably disposed in the bridge portion 828. In operation, sliding the knob proximally relative to the handle longitudinal axis 802 can cause the O-ring 840 to engage the inwardly tapered inner surface of the proximal portion 814 which locks the rotational position of the knob. Conversely, sliding the knob distally relative to the handle longitudinal axis 802 unlocks the knob and allows further rotation. In operation, this O-ring

locking mechanism can enable a physician to lock the filter 214 in any position about and between the collapsed position 216 and the deployed position 218. It is contemplated that such a feature, in combination with the disclosed filter 214, can be useful to adjust the expansion of the filter 214 towards the deployed position 218 and then secure the filter 214 in the selected position while the given intervention is effected.

[0069] In another aspect, each thread of the at least one thread 806 has a pitch 842. In one aspect, the pitch 842 of the at least one thread 806 can be selected to produce a desired axial movement of the screw 804 upon rotation. In a further aspect, the pitch 842 of the at least one thread can be selected to produce axial movement of the screw 804 along the handle longitudinal axis 802 equal to the circumferential movement of the knob.

[0070] In another aspect, the distal end of the distal portion 812 of the handle body 810 can further comprise an opening disposed therein for receiving the proximal ends of both the proximal portion of the catheter 202 and the actuator wire 246. In a further aspect, the distal portion 812 of the handle body 810 can further comprise a luer disposed therein and operably coupled to the distal portion 830 of the knob. In a further aspect, the luer comprises at least one port. Here, it is contemplated that at least the actuator wire 246 passes through the luer, through at least a portion of the hole disposed in the knob and is coupled to the actuator 816. In a further aspect, the actuator wire 246 can be coupled to the screw 804. In another aspect, the luer can comprise a second port and, in a further aspect, the second port can extend through a second opening formed in the distal portion 812 of the handle body 810.

[0071] In operation, rotating the screw 804 in either a clockwise or counterclockwise direction can move the actuator wire 246 back and forth along the catheter longitudinal axis 204. As described above, the actuator wire 246 is coupled to the movable collar 224 of the filter chassis 220. Accordingly, selective rotation of the screw 804 causes the movable collar 224 to be displaced relative to the fixed collar 226 along the catheter longitudinal axis 204. In a first rotational direction of the screw 804, the movable collar 224 is displaced toward the fixed collar 226, expanding the filter 214 towards the deployed position 218. In a second rotational direction of the screw 804, the movable collar 224 is displaced away from the fixed collar 226, moving the filter 214 towards the collapsed position 216. Accordingly, one skilled in the art will appreciate in light of the present disclosure that selectively rotating the screw 804 enables a physician to adjust the degree of expansion of the filter 214 to the target vessel. In one aspect, the screw 804 is actuated via a knob disposed in the bridge portion 828 of the handle 800 as described above. In a further aspect, a physician can secure the filter 214 in any position about and between the

collapsed position 216 and the deployed position 218 by sliding the knob to engage the O-ring locking mechanism. It is contemplated that such a feature, in combination with the disclosed filter 214, can be useful to adjust the expansion of the filter 214 towards the deployed position 218 and then secure the filter 214 in the selected position while the given intervention is affected. As one skilled in the art will appreciate in light of the present disclosure, a physician (or any user) can selectively deploy the filter 214 and engage the O-ring locking mechanism and vice-versa with a single hand.

[0072] In another aspect illustrated in Figure 16, the present disclosure describes a percutaneous transluminal device substantially as described above but having a filter 214 comprising a filter chassis 220 comprising a tubular braided scaffolding 228 having a distal end coupled to a movable collar that is slidably coupled to the catheter and having a proximal end that is coupled to a fixed collar that is spaced from the movable collar relative to the catheter longitudinal axis and immovably coupled to the catheter. Fig. 16 provides from top left corner clockwise: the filter 214 is shown in its initial collapsed state 216. The next figure shows the filter 214 is deployed in an arterial model 950. The third figure shows the filter has captured particles 952. The last figure shows the filter 214 is now collapsed trapping the particles 952 within the filter membrane 222.

[0073] In another aspect, the braided scaffolding can have a shape memory that urges the filter into the collapsed position. It is further contemplated that the braided scaffolding can have a central portion having a maximal radial displacement from the catheter longitudinal axis, or apex, that is greater than a target vessel radius when the filter is in the deployed position. In one aspect, when the filter is in the collapsed position, pulling on the proximal end of the actuator wire exerts a force on the movable collar in a direction relative to the longitudinal axis of the catheter that moves the movable collar toward the fixed collar. It is contemplated that selective movement of the movable collar towards the fixed collar causes the filter to selectively expand, thereby allowing the filter to conformably appose an inner wall of the target vessel. In the selectively expanded configuration, the filter captures substantially 100% of embolic particles having a particle size of at least 150 microns while remaining substantially patent during operation of the angioplasty treatment device and at least until the filter is collapsed for removal of the angioplasty device from the vessel. In another aspect, in the selectively expanded configuration, the shape of the conformably apposed filter and the pore size of the filter membrane cooperate to capture substantially 100% of embolic particles having a particle size of at least 150 microns while the filter remains substantially patent for up to about 5 minutes, more

preferably, up to about 3 minutes, and, most preferably, up to about 1 minute. Figure 17 is a table showing membrane particulate capture efficiency test results for the percutaneous transluminal device described in this disclosure.

[0074] Figure 18 shows the filter 214 in its deployed state inside the model vessel 950. The filter conforms to the vessel walls and creates a tight seal so all particles are efficiently captured. Figure 19 shows the filter 214 in a bend. It depicts the flexibility of the filter 214 to navigate through tight bends.

[0075] In yet another aspect illustrated in Figure 20, the present disclosure describes a percutaneous transluminal device 900 comprising an elongated catheter 902 having a longitudinal axis 904, a proximal end portion 906, a distal end portion 908, and an outer side wall 910; an interventional device 912 operably coupled to at least the distal end portion of the catheter, and a filter 914 operably coupled to the distal end portion of the catheter, wherein the filter can be selectively collapsible and expandable about and between a collapsed position 216 and a deployed position 918. In this aspect, it is contemplated that the percutaneous transluminal device 900 can comprise any of the aspects described above and illustrated in Figures 1-19, unless otherwise noted herein. In one aspect, the elongated catheter is further configured to have a second lumen 920 disposed therein and adapted for slidably receiving at least a portion of a guidewire 922. It is further contemplated that the interventional device 912 comprises an atherectomy device. The atherectomy device can comprise a directional atherectomy device, a rotational atherectomy device or a combination thereof. In another aspect, the elongated catheter 912 further comprises a first elongate catheter 912 and a second elongate catheter 924 having a longitudinal axis 926 coextensive with that of the first catheter 912, a proximal end portion 928, a distal end portion 930, and a lumen 932 disposed therein for slidably receiving at least a portion of the first elongate catheter 912. It is contemplated that the interventional device 912 is disposed on the distal end portion 930 of the second catheter 924. In a further aspect, the interventional device 912 is located proximal to the filter with respect to the longitudinal axis 904 of the first catheter 902.

[0076] It is contemplated that the first elongate catheter 902 can comprise a polymer. In a further aspect, for example and without limitation, the polymer can comprise silicone, polyurethane, polyethylene, PTFE and the like. Alternatively, it is contemplated that the first elongate catheter 902 can comprise a metal. Here, it is contemplated that the metal catheter can

be, for example and without limitation, a 0.014", 0.018", 0.035" wire, having at least one and, preferably, two lumens disposed therein.

[0077] Accordingly, Figures 1–20, and the corresponding text, provide a number of different artificial turf configurations, as well as the devices, methods to form the different artificial turf configurations. In addition to the foregoing, implementations described herein can also be described in terms acts and steps in a method for accomplishing a particular result. For example, a method comprising providing a percutaneous transluminal device according to the present disclosure, inserting the distal portion of the device into a vessel such that the interventional device and the filter are located in a target location, deploying the integrated filter of the device, operating the interventional device; collapsing the integrated filter, and withdrawing the device from the body is described concurrently above with reference to the components and diagrams of Figures 1–20.

[0078] The present invention can thus be embodied in other specific forms without departing from its spirit or essential characteristics. The described aspects are to be considered in all respects only as illustrative and not restrictive. The scope of the invention is, therefore, indicated by the appended claims rather than by the foregoing description. All changes that come within the meaning and range of equivalency of the claims are to be embraced within their scope.

What is Claimed:

1. A percutaneous transluminal device, comprising:
an elongated catheter 202 having a longitudinal axis 204, a proximal end portion 206, a distal end portion 208 and an outer side wall 210;
an interventional device 212 operably coupled to the proximal end portion of the catheter;
a filter 214 operably coupled to the distal end portion of the catheter, the filter selectively collapsible and expandable about and between a collapsed position 216 and a deployed position 218, the filter comprising:

a filter chassis 220 comprising:

a movable collar 224 slidably coupled to the catheter 202,

a fixed collar 226 spaced from the movable collar 224 relative to the longitudinal axis of the catheter, the fixed collar immovably coupled to the catheter, and

a tubular braided scaffolding 228 comprising a plurality of wires 230, the tubular braided scaffolding 228 having a first end coupled to the movable collar and an opposed second end coupled to the fixed collar, each wire of the plurality of wires moves independently with respect to the other wires between the movable collar and the fixed collar as the filter moves between the collapsed position and the deployed position; and

a filter membrane 222 operably coupled to the filter chassis;

an actuator wire having proximal and distal ends, at least a portion of the actuator wire extending through the catheter, the distal end of the actuator wire being coupled to the movable collar;

wherein, when the filter is in the collapsed position, pulling on the proximal end of the actuator wire exerts a force on the movable collar in a direction relative to the longitudinal axis of the catheter that moves the movable collar toward the fixed collar such that the filter chassis expand radially thereby expanding the filter toward the deployed position,

wherein, when the filter is in the deployed position, pushing on the proximal end of the actuator wire exerts a force on the movable collar in a direction relative to the longitudinal axis of the catheter that moves the movable collar away from the fixed collar such that the filter chassis contracts radially thereby contracting the filter toward the collapsed position.

2. The device of claim 1, wherein the movable collar 224 is slidably coupled to the catheter 202 proximate the distal end portion 208 of the catheter and the a fixed collar 226 is

coupled to the catheter at a location between the movable collar and the proximal end portion 206 of the catheter.

3. The device of claim 1, wherein as a distance between the movable collar 224 and the fixed collar 226 along the longitudinal axis of the catheter is decreased, a central portion 232 of the tubular braided scaffolding radially expands, causing the filter to expand towards the deployed position.

4. The device of claim 3, wherein the central portion defines a maximum radial displacement of the tubular braided scaffolding from the catheter longitudinal axis, wherein the maximum radial displacement is greater than a target vessel radius when the filter is in the deployed position.

5. The device of claim 1, wherein when the filter in the expanded position, the filter chassis is sized and configured to conform to a shape of a target vessel over a length of the target vessel.

6. The device of claim 1, wherein the filter in the deployed position captures substantially 100% of embolic particles having a particle size of at least 150 microns while remaining substantially patent during operation of the interventional device and at least until the filter is collapsed for removal of the interventional device from the vessel.

7. The device of claim 1, wherein each wire of the plurality of wires extends between the first and second ends of the braided scaffolding, wherein each wire of the plurality of wires further comprises at least one crossover portion and at least one non-crossover portion.

8. The device of claim 7, wherein the tubular braided scaffolding includes from about 6 to about 20 wire crossover portions per inch along a length of at least on the plurality of wires.

9. The device of claim 7, wherein the tubular braided scaffolding includes alternating crossover portions and non-crossover portions along each of the plurality of wires.

10. The device of claim 7, wherein the tubular braided scaffolding includes a one-to-two ratio of alternating crossover portions and non-crossover portions along each of the plurality of wires.

11. The device of claim 7, wherein the crossover portion of a wire of the plurality of wires slidably contacts an other wire of the plurality of wires as the filter moves between the collapsed position and the deployed position.

12. The device of claim 1, wherein each of the plurality of wires of the tubular braided scaffolding is formed from a shape memory material.

13. The device of claim 12, wherein the tubular braided scaffolding can have a shape memory corresponding to the collapsed position of the filter.
14. The device of claim 1, wherein at least one of the wires of the plurality of wires is formed from a shape memory material and a remainder of the plurality of wires is formed from a non-shape memory material.
15. The device of claim 7, wherein the filter membrane is coupled to the at least one non-crossover portion.
16. The device of claim 15, wherein the filter membrane is coupled a non-crossover portion provided at a location proximate a maximum radial displacement 234 of the filter chassis when in the deployed position.
17. The device of claim 1, wherein the filter membrane extends beyond the filter chassis in a longitudinal direction relative to the longitudinal axis of the catheter.
18. The device of claim 1, wherein the filter membrane comprises a braided mesh 700 operably coupled to the filter chassis.
19. The device of claim 18, wherein the braided mesh is disposed an interior surface 702 of the filter chassis 220.
20. The device of claim 18, wherein the braided mesh is a dual layer braided mesh.
21. The device of claim 18, wherein the braided mesh comprises a shape memory material having shape memory corresponding to deployed position of the filter, wherein the tubular braided scaffolding comprises a shape memory material having a shape memory corresponding to the collapsed position of the filter.
22. The device of claim 18, wherein the braided mesh comprises a polymer.
23. The device of claim 18, wherein the braided mesh has a pore size of less than 100 microns.
24. The device of claim 1, wherein the catheter further comprises a lumen and a port in communication with the lumen, the port comprising an aperture in the outer side wall of the catheter located in between the fixed collar and the movable collar, and the lumen extending from the proximal end portion of the catheter to the port, wherein the actuator wire extends through the lumen, the distal end of the of the actuator exiting the lumen through the port.
25. The device of claim 1, wherein movement of the movable collar toward the fixed collar causes a central portion of the filter chassis to radially expand.

26. The device of claim 1, wherein the interventional device is an angioplasty device the angioplasty device including at least one of an angioplasty balloon, a stent, a mechanical thrombectomy device, an atherectomy device.

27. The device of claim 26, wherein the atherectomy device includes at least one of a rotational atherectomy device, a directional atherectomy device, and a combination rotational-directional atherectomy device.

28. The device of claim 1, wherein the interventional device can perform at least one of an angioplasty, a valvuloplasty, and an ablation.

29. A percutaneous, transluminal angioplasty device comprising:
an elongated catheter having a longitudinal axis, a proximal end portion, a distal end portion and an outer side wall;
an interventional device operably coupled to the proximal end portion of the catheter;
a filter operably coupled to the distal end portion of the catheter, the filter movable between a collapsed position and a deployed position, the filter comprising:
a filter chassis comprising:
a tubular braided scaffolding having a distal end coupled to a movable collar slidably coupled to the catheter and a proximal end coupled to a fixed collar spaced from the movable collar and immovably coupled to the catheter, and
a filter membrane coupled to the tubular braided scaffolding and extending to at least the distal end of the filter chassis; and
an actuator wire, at least a portion of the actuator wire extending within the catheter, a distal end of the actuator wire exiting the catheter through a port provided on an outer side wall of the catheter, a distal end of the actuator wire being coupled to the movable collar;
a handle coupled to the proximal end portion of the catheter and operably coupled to a proximal end of the actuator wire at a screw, and an actuator coupled to the screw, the activation of the actuator effecting axial displacement of the screw, and, correspondingly, the actuator wire, relative to the handle longitudinal axis,

wherein rotation of the screw causes the actuator wire to move along the longitudinal axis of the catheter, where movement of the actuator wire causes the filter to move between the collapsed position and the deployed position by exerting a force on and moving the movable collar relative to the fixed collar along the longitudinal axis of the catheter.

30. The device of claim 29, wherein during a first rotational direction of the screw 804, the movable collar 224 is displaced toward the fixed collar 226, expanding the filter 214 towards the deployed position 218, and during a second rotational direction of the screw 804, the

movable collar 224 is displaced away from the fixed collar 226, moving the filter 214 towards the collapsed position 216.

31. The device of claim 29, wherein the handle further comprises:

a distal portion 812;

a proximal portion 814 including a distal stop 822, a proximal stop 824, and a plurality of thread-receiving members 826 for engaging the at least one thread 806 of the screw positioned between the distal and proximal stops 822, 824 relative to a longitudinal axis 802 of the handle such that distal stop 822 limits distal axial movement of the screw 804 and the proximal stop 824 limits proximal axial movement of the screw 804; and

bridge portion 828 extending between and connected to the proximal portion 814 and the distal portion 812.

32. The device of claim 31, wherein a distal portion 830 of the actuator is positioned in at least one of slidable and rotatable engagement with a proximal end 836 of the distal portion 812 of the handle,

wherein a proximal portion 834 of the knob is positioned in at least one of slidable and rotatable engagement with a distal end 838 of the proximal portion 814 of the handle.

33. The device of claim 31, wherein an inner surface of the distal end 838 of the proximal portion 814 of the handle body 810 is inwardly tapered relative to the handle longitudinal axis 802,

wherein a proximal portion 834 of the actuator further comprises an O-ring 840 fixed to the outer surface thereof, the actuator slidably disposed in the handle such that sliding the knob proximally relative to the handle longitudinal axis 802 causes the O-ring 840 to engage the inwardly tapered inner surface of the proximal portion 814 thereby locking a rotational position of the actuator.

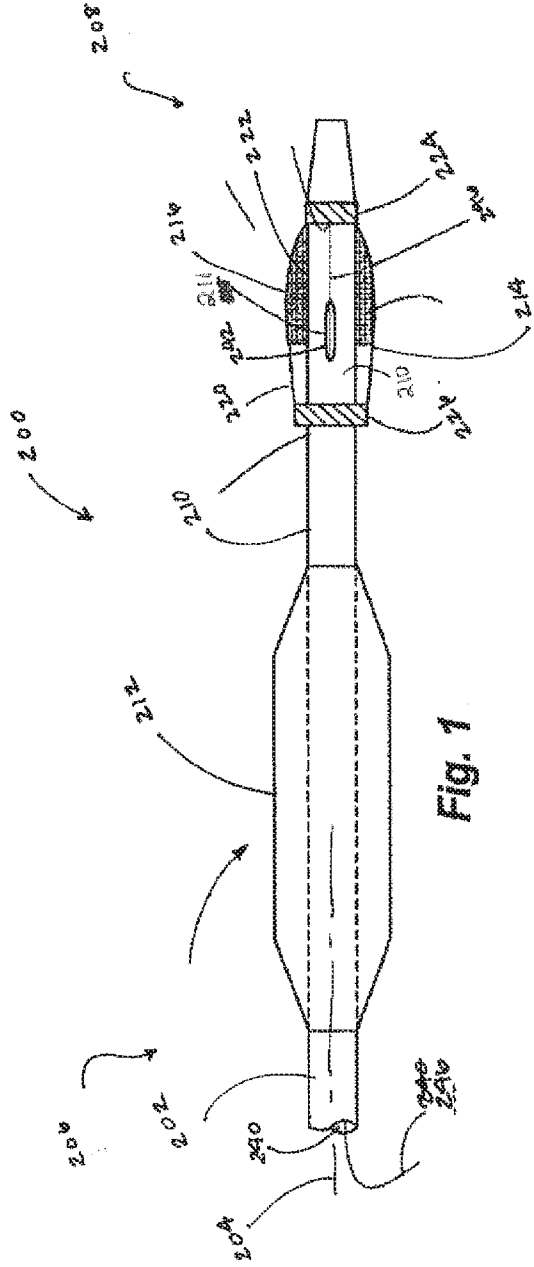

Fig. 1

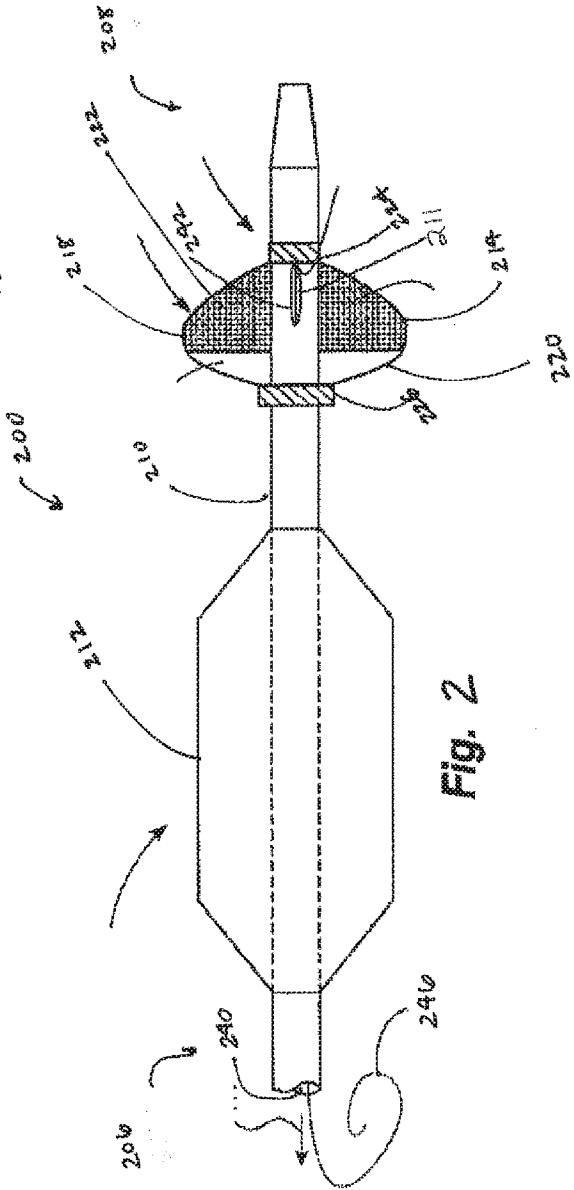

Fig. 2

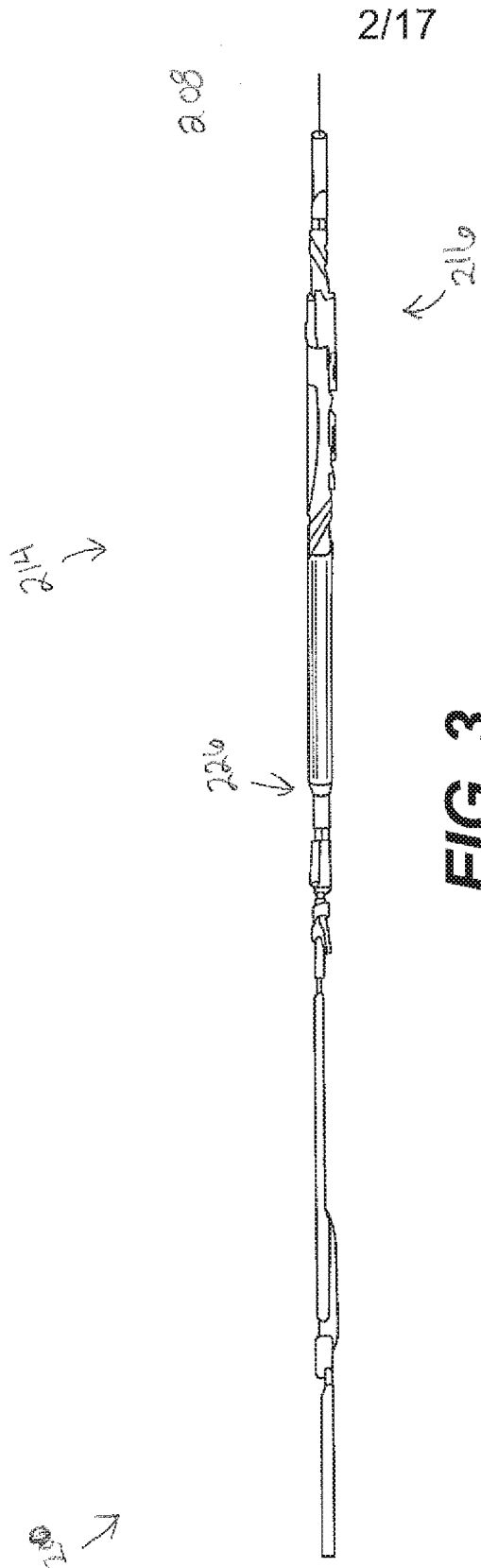

FIG. 3

3/17

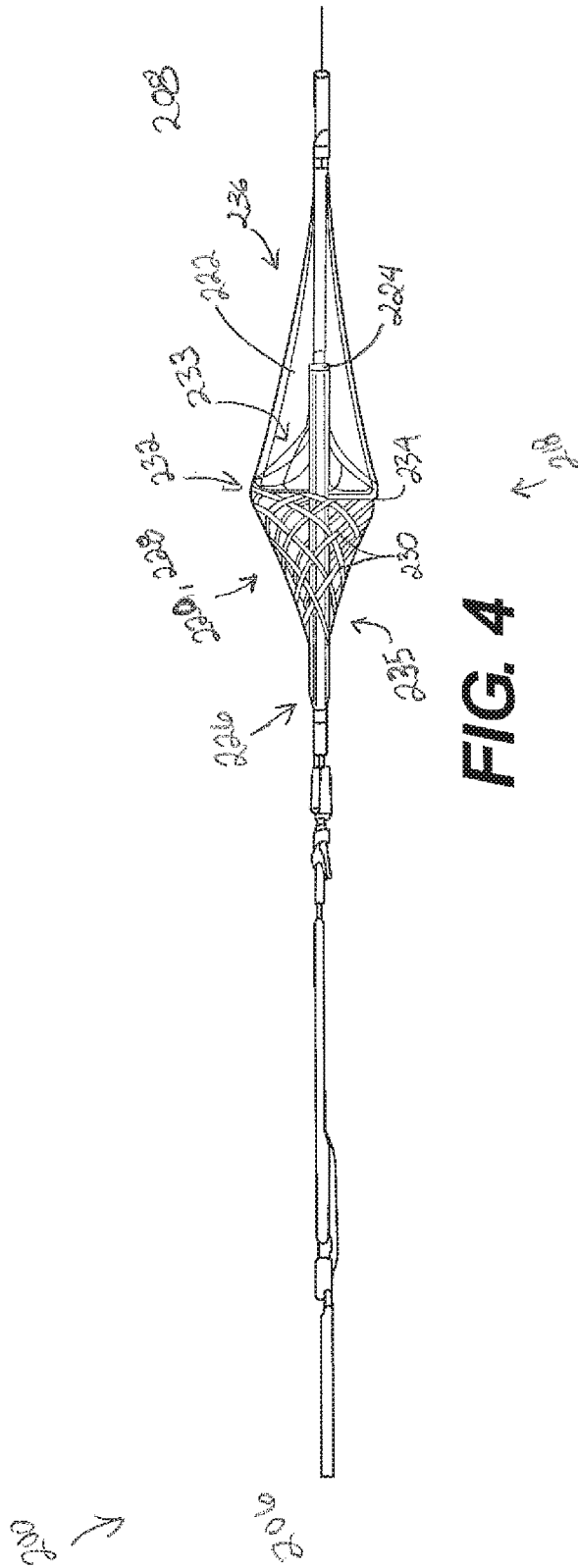
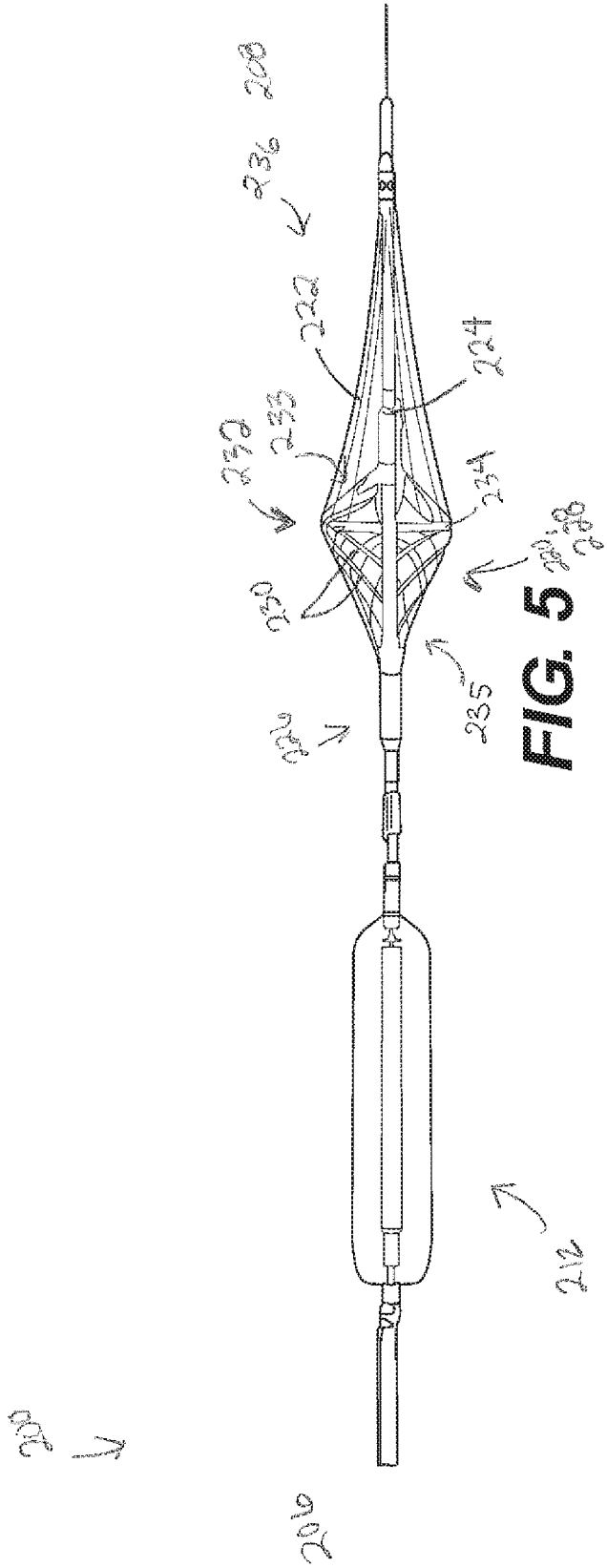

FIG. 4

4/17



6/17

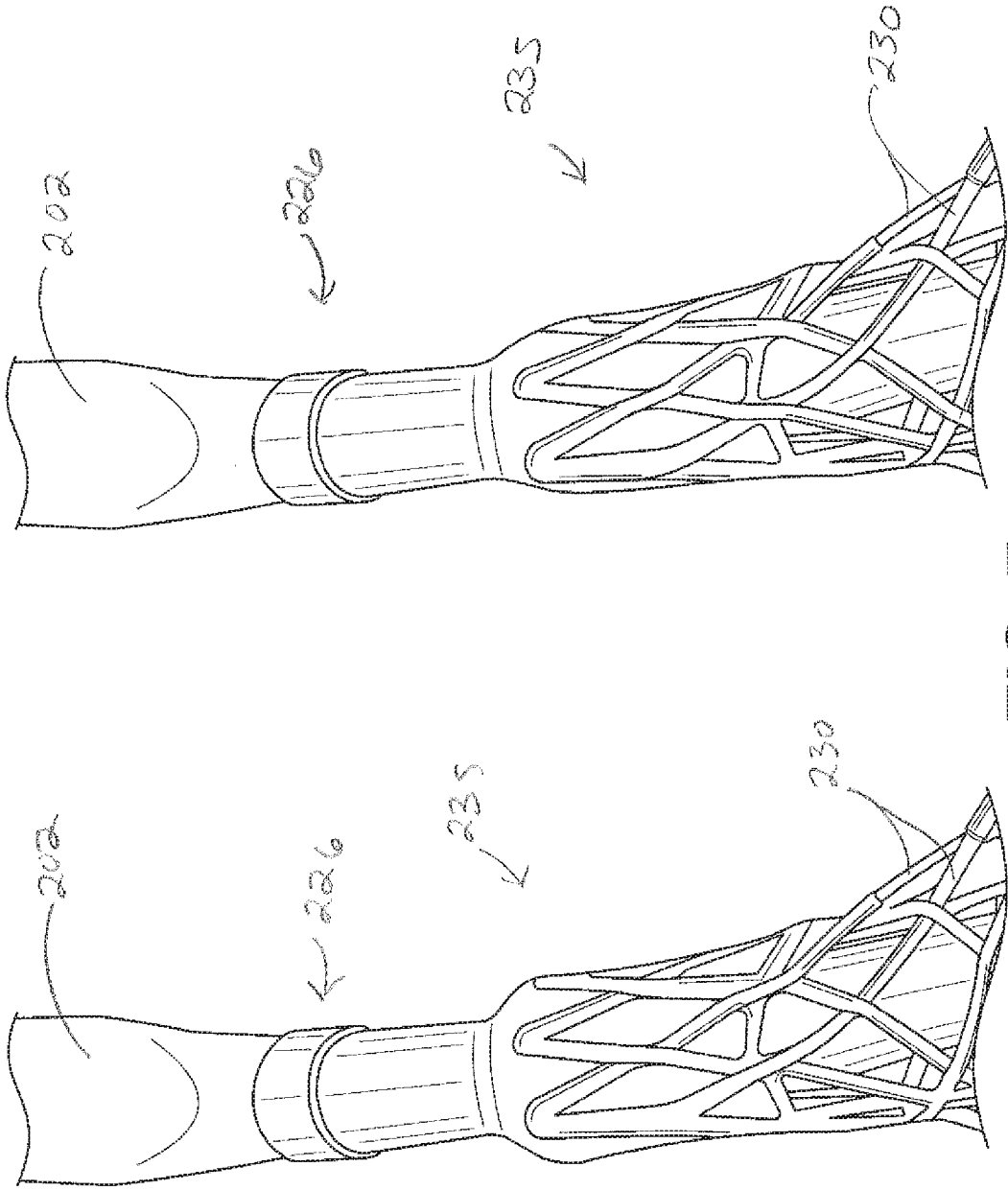

FIG. 7

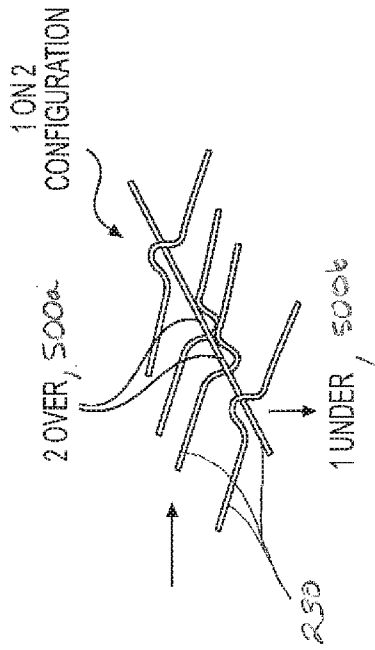

FIG. 8B

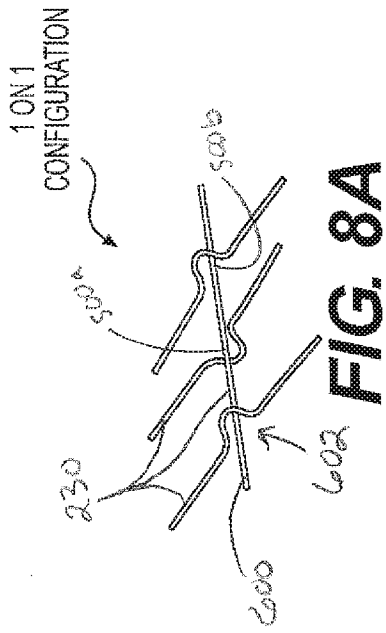

FIG. 8A

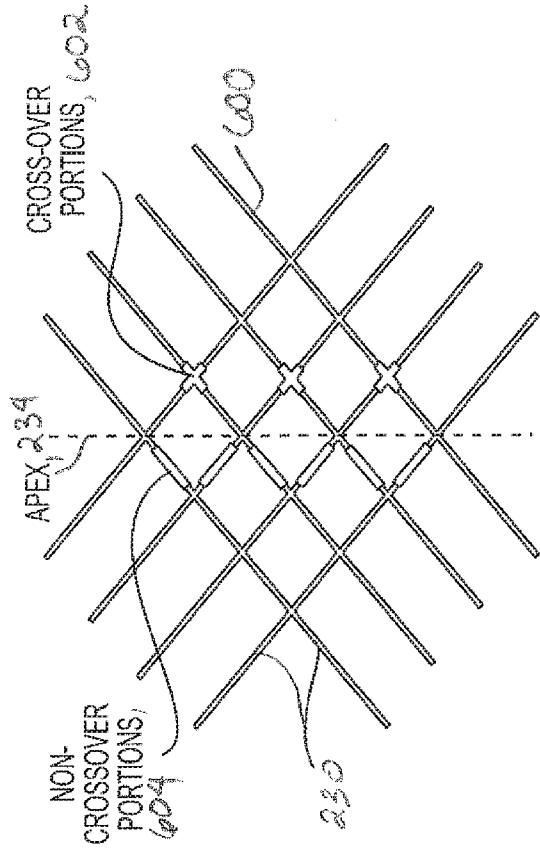

FIG. 9

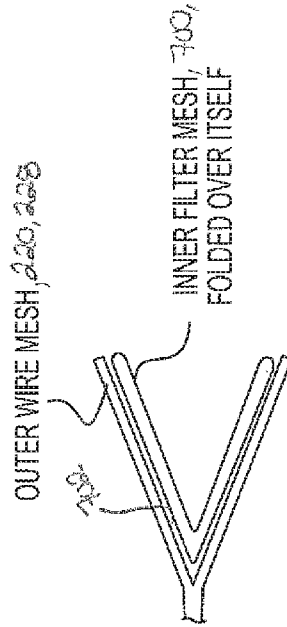

FIG. 10

8/17

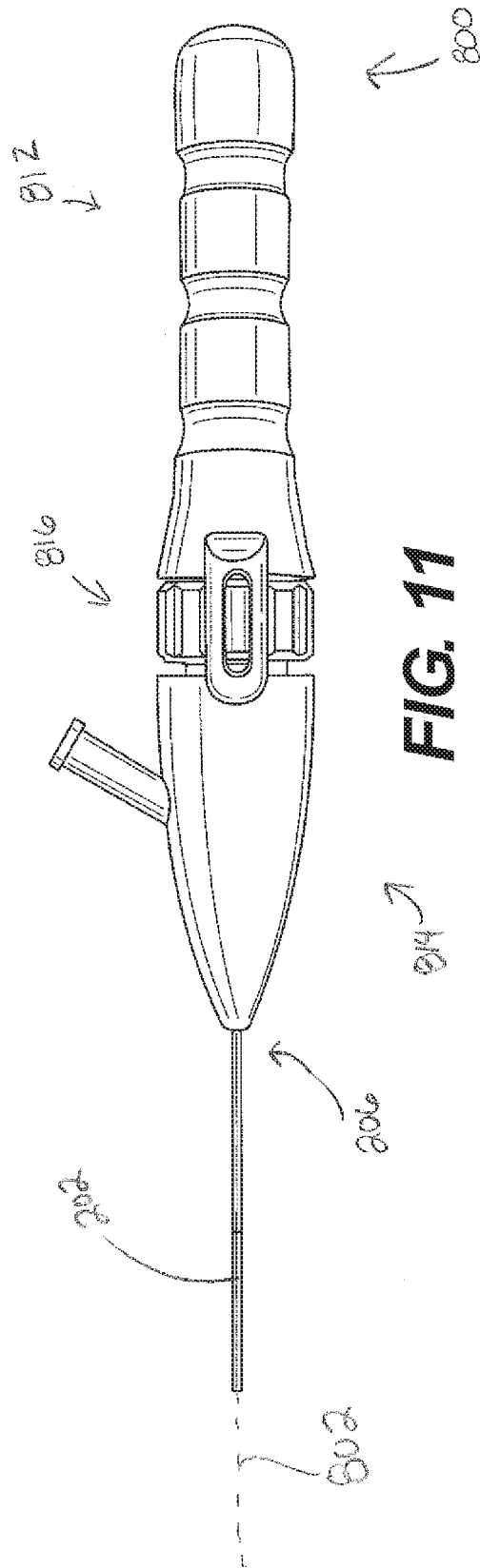

FIG. 11

9/17

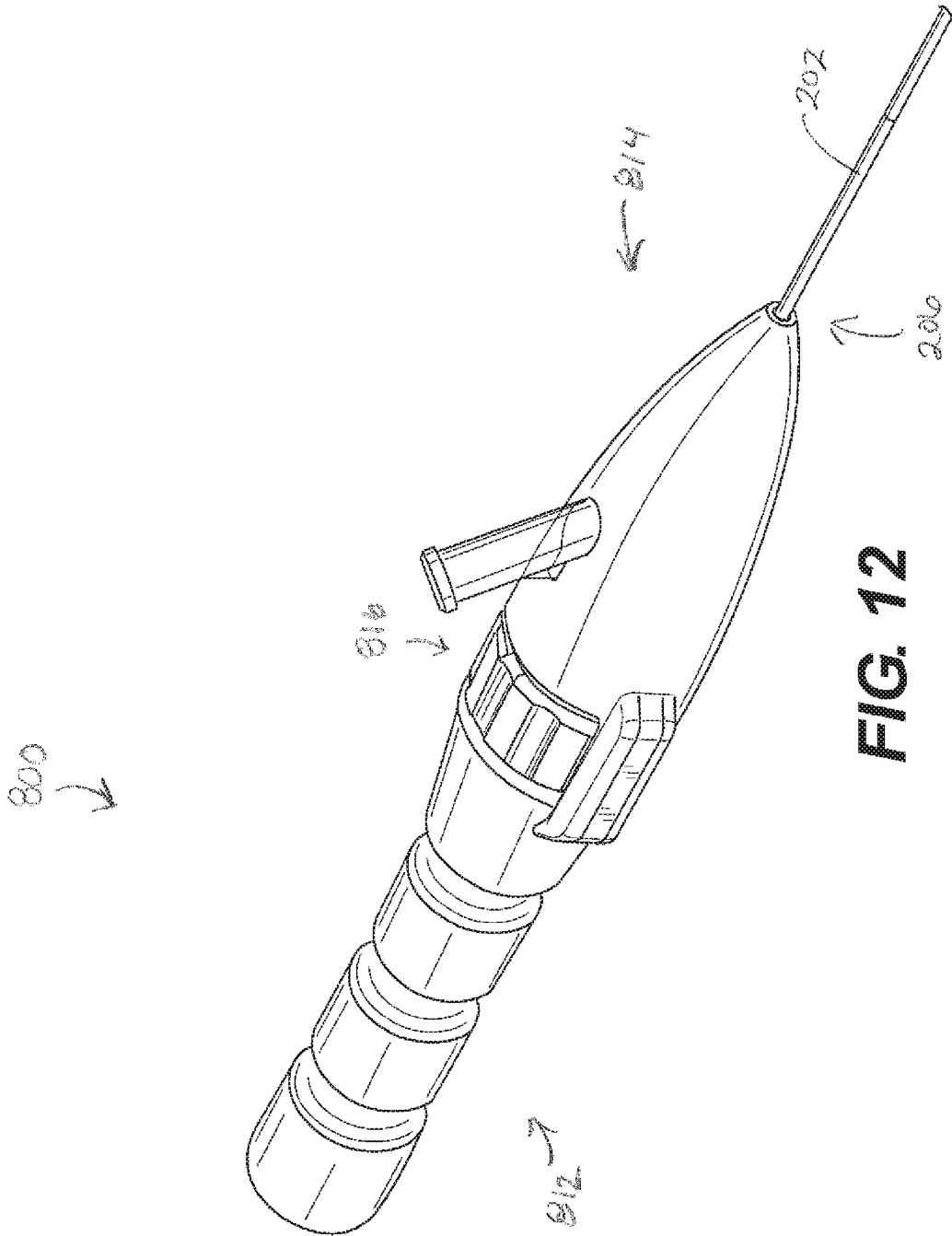

FIG. 12

10/17

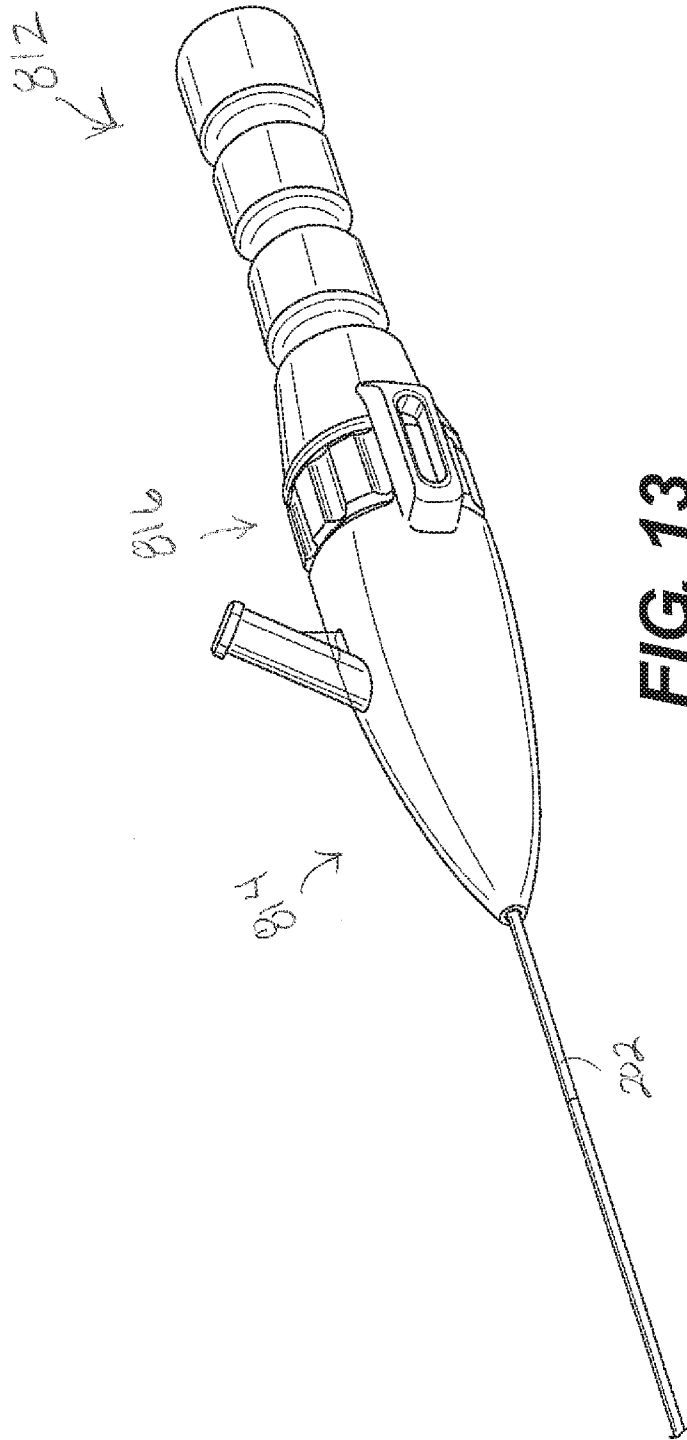
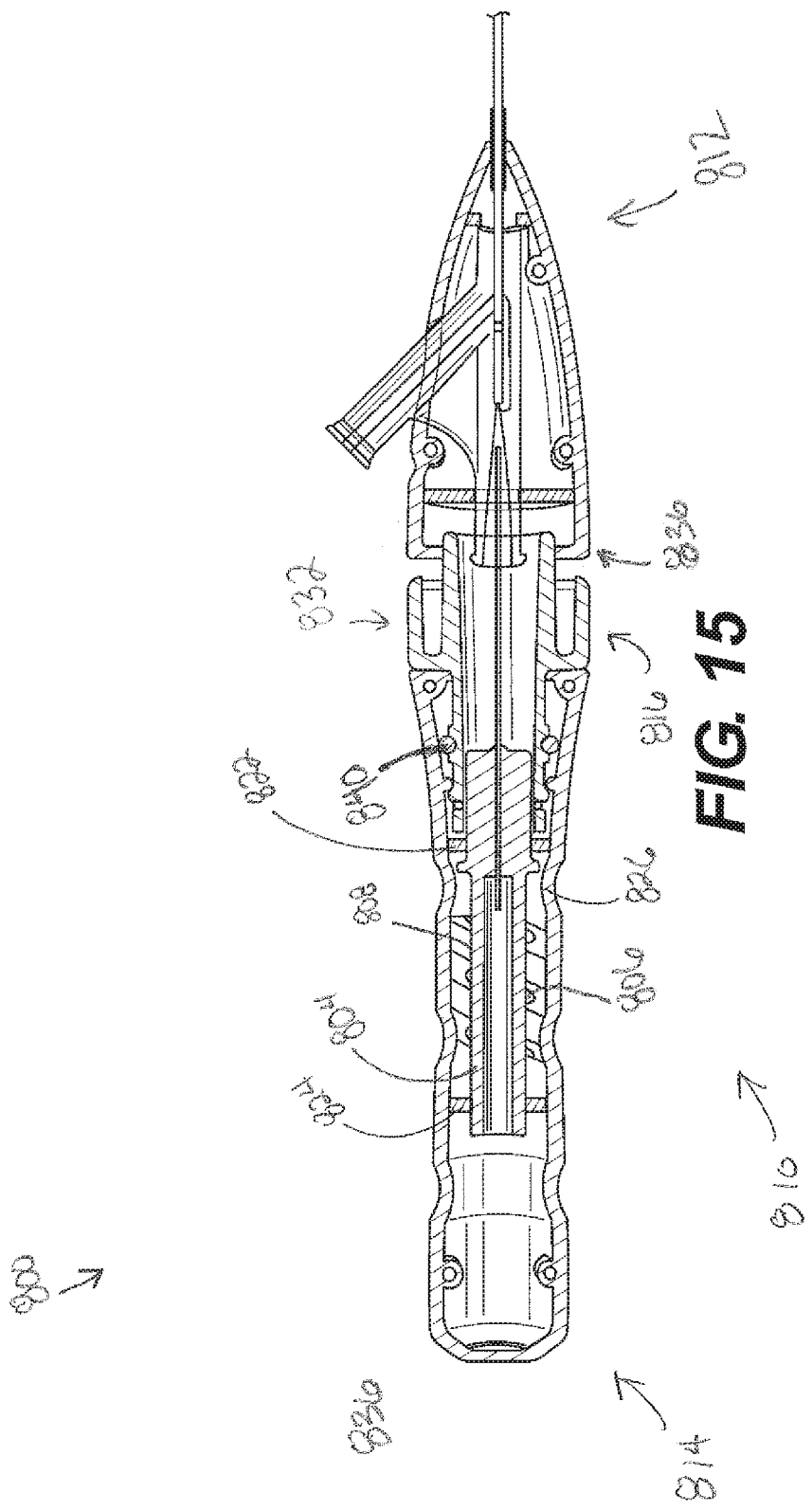

FIG. 13

12/17



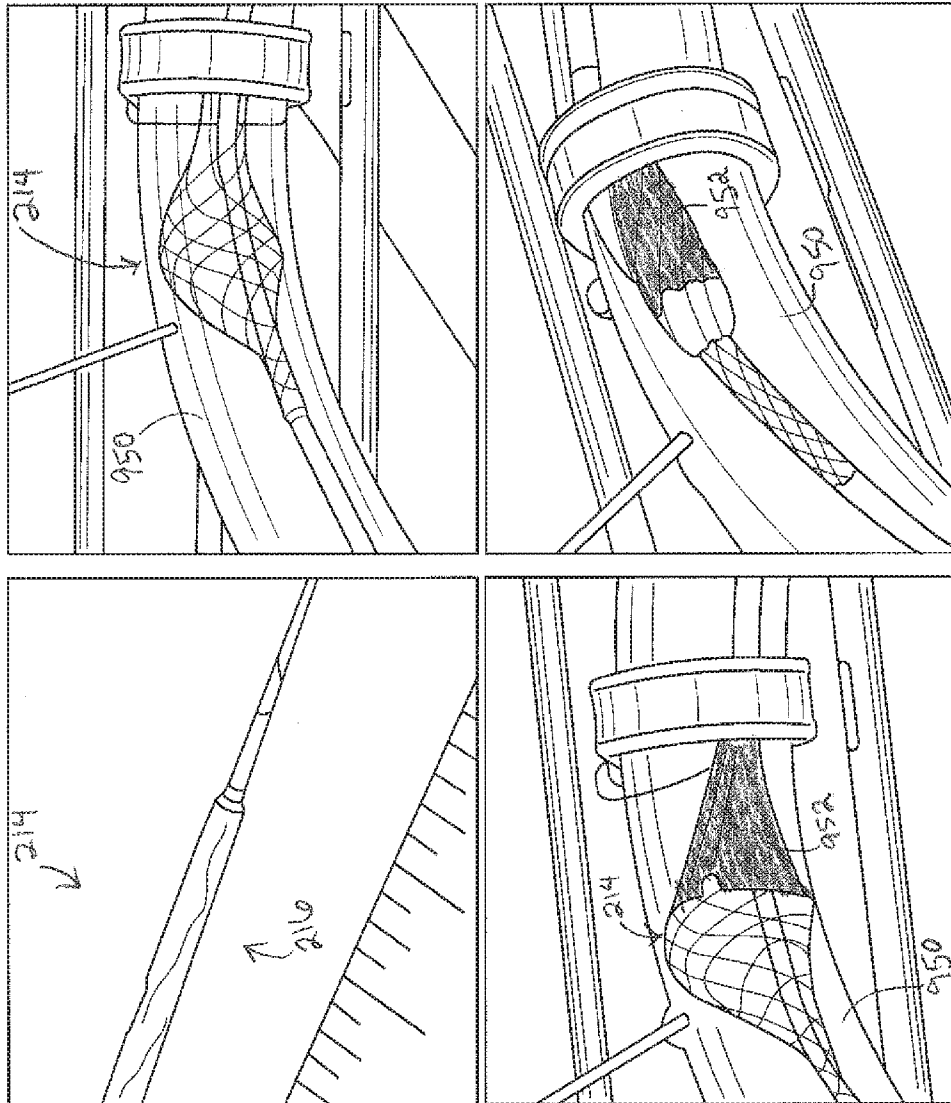

FIG. 16

14/17

MEMBRANE PARTICULATE CAPTURE EFFICIENCY TEST RESULTS

SAMPLE	START FLOW RATE (mL/min)	DEPLOYED FILTER FLOW RATE (mL/min)	CAPTURE PERCENTAGE
1	111.85	112.22	100%
2	92.2	93.7	100%
3	111.46	111.26	100%
4	114.5	115.28	100%
5	110.0	109.92	100%
6	113.72	114.0	100%
7	111.1	111.4	100%
8	108.4	105.5	100%
9	110.06	109.92	100%
10	109.2	110.0	100%
11	109.8	108.6	100%
12	111.6	109.2	100%
13	111.6	110.6	100%
14	107.4	107.0	100%
15	107.2	107.0	100%

FIG. 17

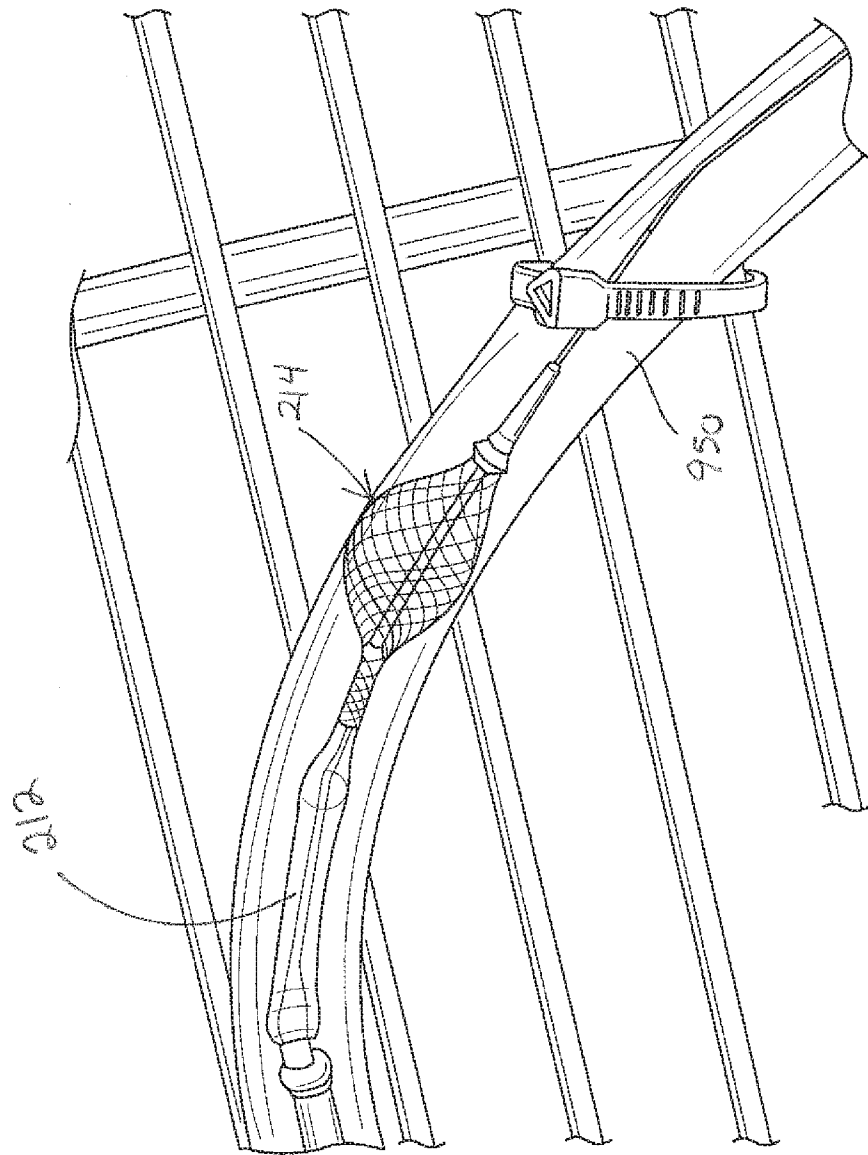

FIG. 18

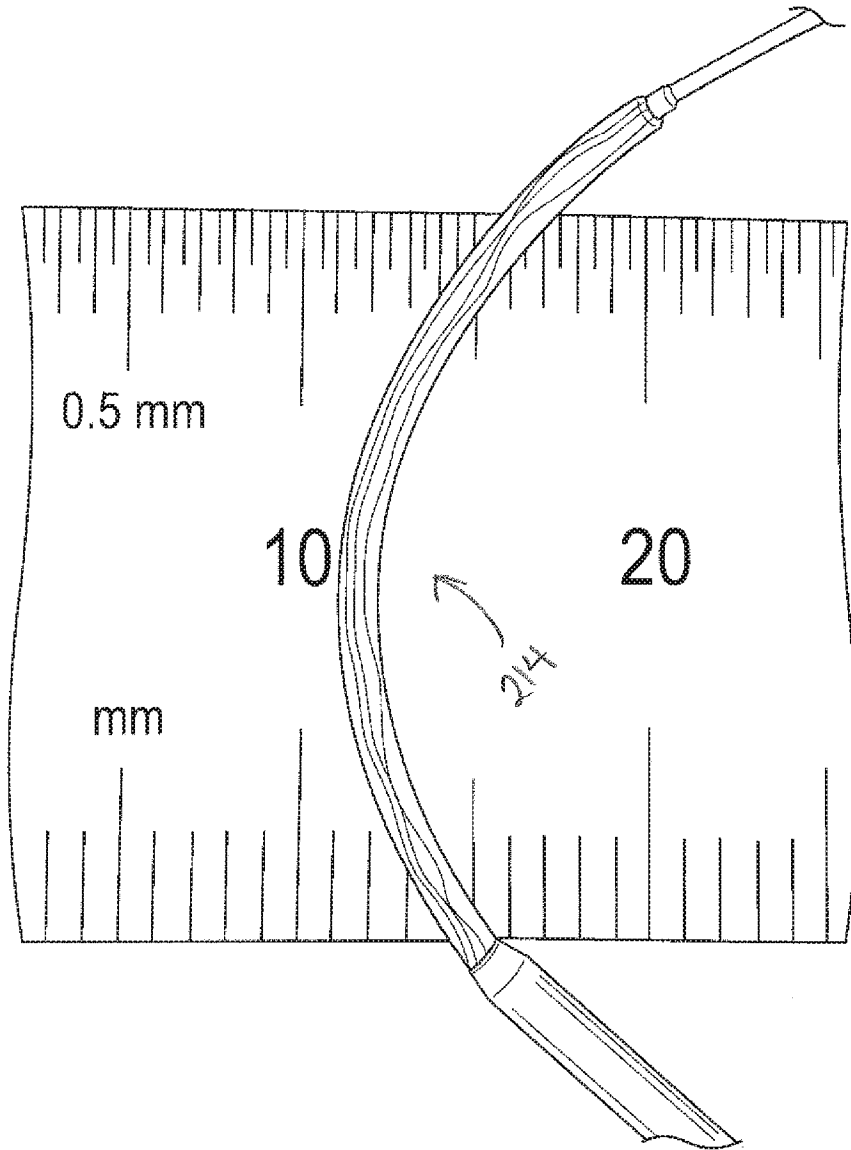

FIG. 19

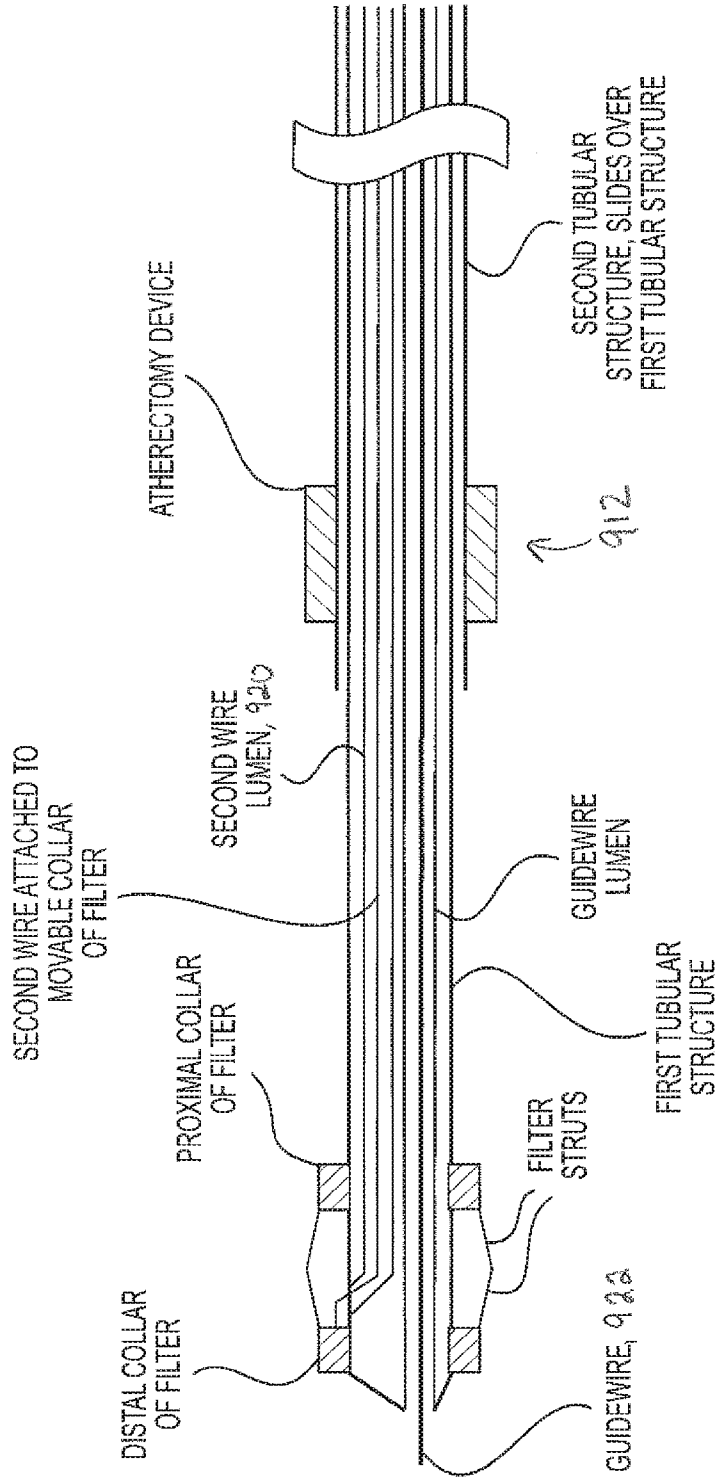

FIG. 20

INTERNATIONAL SEARCH REPORT

International application No.

PCT/US16/14763

A. CLASSIFICATION OF SUBJECT MATTER

IPC(8) - A61M 25/00; A61F 2/01 (2016.01)

CPC - A61 M25/00; A61F 2/013

According to International Patent Classification (IPC) or to both national classification and IPC

B. FIELDS SEARCHED

Minimum documentation searched (classification system followed by classification symbols)

IPC (8) - A61M 25/00; A61F 2/01; A61L 31/14 (2016.01)

CPC - A61 M25/00; A61F 2/01, 2/013, 2002/011, 2250/00; A61L 31/14

Documentation searched other than minimum documentation to the extent that such documents are included in the fields searched

Electronic data base consulted during the international search (name of data base and, where practicable, search terms used)

PatSeer (US, EP, WO, JP, DE, GB, CN, FR, KR, ES, AU, IN, CA, INPADOC Data); Google/Google Scholar; PubMed; EBSCO Discovery
Search terms: catheter, wire, expand, collapse, embolism, filter, scaffold, wire, braid, independent, membrane, crossover, shape memory

C. DOCUMENTS CONSIDERED TO BE RELEVANT

Category*	Citation of document, with indication, where appropriate, of the relevant passages	Relevant to claim No.
Y	US 2014/0214067 A1 (CONTEGO MEDICAL, LLC) July 31, 2014; figures 1, 2, 16, 17, 25, 42-47; paragraphs [0072]; [0111], [0112], [0114], [011]	1-28
Y	US 8795305 B2 (LAZARUS EFFECT, INC.) August 05, 2014; figures 12A,B; column 8, lines 45-50; column 19, lines 37-57; column 19, line 60-column 19, line 6	1-28
Y	US 2010/0286722 A1 (RIZK, I) November 11, 2010; paragraph [0052]	5
Y	US 2014/0343663 A1 (RAPID MEDICAL, LTD.) November 20, 2014; paragraph [0060]	8
Y	US 2011/0152993 A1 (MARCHAND, P) June 23, 2011; paragraph [0125]	10
Y	US 2004/0082967 A1 (BROOME, TE) April 29, 2004; paragraphs [0026], [0040], [0041], [0111]	18-20, 22, 23
Y	US 2004/0111111 A1 (LIN, HB) June 10, 2004; paragraph [0073]	21
Y	ROBERTS, D et al. Effective endovascular treatment of calcified femoropopliteal disease with directional atherectomy and distal embolic protection: Final Results of the DEFINITIVE Ca++ Trial. Catheterization and Cardiovascular Interventions, Volume 84 (2014), pp. 236-244. [retrieved on 2016-03-14]. Retrieved from the Internet <URL: http://www.ncbi.nlm.nih.gov/pmc/articles/PMC4282091/ ><DOI:10.1002/ccd.25384>	27

 Further documents are listed in the continuation of Box C. See patent family annex.

* Special categories of cited documents:

"A" document defining the general state of the art which is not considered to be of particular relevance

"E" earlier application or patent but published on or after the international filing date

"L" document which may throw doubts on priority claim(s) or which is cited to establish the publication date of another citation or other special reason (as specified)

"O" document referring to an oral disclosure, use, exhibition or other means

"P" document published prior to the international filing date but later than the priority date claimed

"T" later document published after the international filing date or priority date and not in conflict with the application but cited to understand the principle or theory underlying the invention

"X" document of particular relevance; the claimed invention cannot be considered novel or cannot be considered to involve an inventive step when the document is taken alone

"Y" document of particular relevance; the claimed invention cannot be considered to involve an inventive step when the document is combined with one or more other such documents, such combination being obvious to a person skilled in the art

"&" document member of the same patent family

Date of the actual completion of the international search

16 March 2016 (16.03.2016)

Date of mailing of the international search report

05 JUL 2016

Name and mailing address of the ISA/

Mail Stop PCT, Attn: ISA/US, Commissioner for Patents
P.O. Box 1450, Alexandria, Virginia 22313-1450

Facsimile No. 571-273-8300

Authorized officer

Shane Thomas

PCT Helpdesk: 571-272-4300
PCT OSP: 571-272-7774

INTERNATIONAL SEARCH REPORT

International application No.

PCT/US16/14763

Box No. II Observations where certain claims were found unsearchable (Continuation of item 2 of first sheet)

This international search report has not been established in respect of certain claims under Article 17(2)(a) for the following reasons:

1. Claims Nos.:
because they relate to subject matter not required to be searched by this Authority, namely:

2. Claims Nos.:
because they relate to parts of the international application that do not comply with the prescribed requirements to such an extent that no meaningful international search can be carried out, specifically:

3. Claims Nos.:
because they are dependent claims and are not drafted in accordance with the second and third sentences of Rule 6.4(a).

Box No. III Observations where unity of invention is lacking (Continuation of item 3 of first sheet)

This International Searching Authority found multiple inventions in this international application, as follows:

This application contains the following inventions or groups of inventions which are not so linked as to form a single general inventive concept under PCT Rule 13.1. In order for all inventions to be examined, the appropriate additional examination fees must be paid.

Group I: Claims 1-28 are directed toward a percutaneous transluminal device comprising a filter having a tubular braided scaffolding comprising a plurality of wires, wherein each of the wires moves independently of the other wires.

Group II: Claims 29-33 are directed toward a percutaneous transluminal device comprising a handle coupled to the proximal end portion of the catheter and operably coupled to a proximal end of the actuator wire at a screw, and an actuator coupled to the screw.

The inventions listed as Groups I-II do not relate to a single general inventive concept under PCT Rule 13.1 because, under PCT Rule 13.2, they lack the same or corresponding special technical features for the following reasons:

-See Supplemental Page-

1. As all required additional search fees were timely paid by the applicant, this international search report covers all searchable claims.
2. As all searchable claims could be searched without effort justifying additional fees, this Authority did not invite payment of additional fees.
3. As only some of the required additional search fees were timely paid by the applicant, this international search report covers only those claims for which fees were paid, specifically claims Nos.:

4. No required additional search fees were timely paid by the applicant. Consequently, this international search report is restricted to the invention first mentioned in the claims; it is covered by claims Nos.:
1-28

- Remark on Protest**
- The additional search fees were accompanied by the applicant's protest and, where applicable, the payment of a protest fee.
 - The additional search fees were accompanied by the applicant's protest but the applicable protest fee was not paid within the time limit specified in the invitation.
 - No protest accompanied the payment of additional search fees.

INTERNATIONAL SEARCH REPORT
Information on patent family members

International application No.

PCT/US16/14763

---Continued from Box III: Lack of Unity of Invention---

Group I includes a tubular braided scaffolding comprising a plurality of wires, wherein each of the wires moves independently of the other wires, which is not present in Group II.

Group II includes a handle coupled to the proximal end portion of the catheter and operably coupled to a proximal end of the actuator wire at a screw, and an actuator coupled to the screw, which is not present in Group I.

The common technical features of Groups I and II are a percutaneous, transluminal angioplasty device comprising: an elongated catheter having a longitudinal axis, a proximal end portion, a distal end portion and an outer side wall; an interventional device operably coupled to the proximal end portion of the catheter; a filter operably coupled to the distal end portion of the catheter, the filter movable between a collapsed position and a deployed position, the filter comprising: a filter chassis comprising: a tubular braided scaffolding having a distal end coupled to a movable collar slidably coupled to the catheter and a proximal end coupled to a fixed collar spaced from the movable collar and immovably coupled to the catheter, and a filter membrane coupled to the tubular braided scaffolding and extending to at least the distal end of the filter chassis; and an actuator wire, at least a portion of the actuator wire extending within the catheter, a distal end of the actuator wire exiting the catheter through a port provided on an outer side wall of the catheter, a distal end of the actuator wire being coupled to the movable collar.

These common technical features are disclosed by US 2014/0214067 A1 to CONTEGO MEDICAL, LLC (hereinafter 'Contego'). Contego discloses a percutaneous transluminal device, comprising: an elongated catheter having a longitudinal axis, a proximal end portion (an elongated catheter having proximal and distal ends; claim 18, line 3), a distal end portion and an outer side wall (all catheters have distal ends and outer side walls); an interventional device operably coupled to the proximal end portion of the catheter (an interventional device attached to the catheter adjacent the distal end thereof; claim 18, lines 4-5); a filter operably coupled to the distal end portion of the catheter, the filter selectively collapsible and expandable about and between a collapsed position and a deployed position (a filter attached to the elongated catheter between the interventional device and the distal end of the catheter; claim 18, lines 6-7) the filter comprising: a filter chassis comprising: a movable collar slidably coupled to the catheter (a movable ring portion movably attached to the catheter; claim 18, line 14), a fixed collar spaced from the movable collar relative to the longitudinal axis of the catheter, the fixed collar immovably coupled to the catheter (fixed ring portion movably attached to the catheter, claim 18, lines 15-17) and a tubular braided scaffolding comprising a plurality of wires (claim 31, which is dependent on claim 18, discloses a braided scaffolding comprising a plurality of wires; in the embodiment shown in figures 44-47 and described in paragraph [0112], the scaffolding is tubular), the tubular braided scaffolding having a first end coupled to the movable collar (a distal end of the wire mesh frame is coupled to the movable ring portion; claim 18, lines 20-22) and an opposed second end coupled to the fixed collar (a proximal end of the wire mesh frame is coupled to the fixed ring portion; claim 18, lines 22-24), and a filter membrane operably coupled to the filter chassis (a filter mesh overlying a portion of the wire mesh frame; claim 18, line 25); an actuator wire having proximal and distal ends (an actuator wire having proximal and distal ends; claim 18, line 28), at least a portion of the actuator wire extending through the catheter (the actuator wire extending through the lumen of the catheter; claim 18, lines 29-30), the distal end of the actuator wire being coupled to the movable collar (the distal end of the actuator wire being attached to the movable ring portion; claim 18, lines 36-36).

Since the common technical features are previously disclosed by the Contego reference, the common features are not special and so Groups I and II lack unity.