

(19) World Intellectual Property Organization
International Bureau



(43) International Publication Date
30 January 2003 (30.01.2003)

PCT

(10) International Publication Number
WO 03/008183 A1

(51) International Patent Classification⁷: **B31F 1/07**

(21) International Application Number: PCT/EP02/04460

(22) International Filing Date: 23 April 2002 (23.04.2002)

(25) Filing Language: English

(26) Publication Language: English

(30) Priority Data:
0117289.9 16 July 2001 (16.07.2001) GB

(71) Applicant: **SCA HYGIENE PRODUCTS GMBH**
[DE/DE]; Sandhofer Strasse 176, 68305 Mannheim (DE).

(72) Inventor: **LOFINK, Bernd**; Mohngasse 18, 67246 Dirmstein (DE).

(74) Agents: **HOFFMANN EITL**_ et al.; Arabellastrasse 4, 81925 München (DE).

(81) Designated States (national): AE, AG, AL, AM, AT, AU, AZ, BA, BB, BG, BR, BY, BZ, CA, CH, CN, CO, CR, CU,

CZ, DE, DK, DM, DZ, EC, EE, ES, FI, GB, GD, GE, GH, GM, HR, HU, ID, IL, IN, IS, JP, KE, KG, KP, KR, KZ, LC, LK, LR, LS, LT, LU, LV, MA, MD, MG, MK, MN, MW, MX, MZ, NO, NZ, OM, PH, PL, PT, RO, RU, SD, SE, SG, SI, SK, SL, TJ, TM, TN, TR, TT, TZ, UA, UG, UZ, VN, YU, ZA, ZM, ZW.

(84) Designated States (regional): ARIPO patent (GH, GM, KE, LS, MW, MZ, SD, SL, SZ, TZ, UG, ZM, ZW), Eurasian patent (AM, AZ, BY, KG, KZ, MD, RU, TJ, TM), European patent (AT, BE, CH, CY, DE, DK, ES, FI, FR, GB, GR, IE, IT, LU, MC, NL, PT, SE, TR), OAPI patent (BF, BJ, CF, CG, CI, CM, GA, GN, GQ, GW, ML, MR, NE, SN, TD, TG).

Declaration under Rule 4.17:

— as to applicant's entitlement to apply for and be granted a patent (Rule 4.17(ii)) for all designations

Published:

— with international search report

For two-letter codes and other abbreviations, refer to the "Guidance Notes on Codes and Abbreviations" appearing at the beginning of each regular issue of the PCT Gazette.

(54) Title: DEVICE FOR APPLYING AN EMBOSsing TO A WEB OF TISSUE PAPER

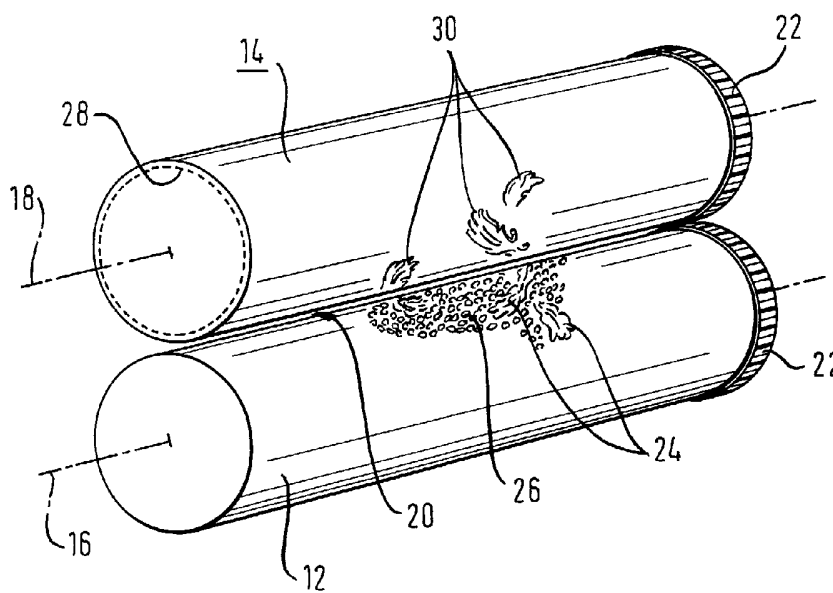

(57) Abstract: An embossing device for embossing a single-ply or multi-ply web of tissue paper comprises a first steel roll (12) with embossing protuberances (24, 26) on its peripheral surface and a second roll (14) with a yielding layer (32) on its peripheral surface. The second roll cooperates with the steel roll (12) so as to form an embossing nip (20) therewith. The steel roll (12) and the second roll (14) run in synchronisation. The second roll (14) has individual zones (30) on its peripheral surface with a higher overall thickness and/or different material characteristics of the yielding layer (32; 32, 34) compared to that of the remaining peripheral surface. These individual zones (30) are opposed in the embossing nip (20) to embossing protuberances of the steel roll (12).



WO 03/008183 A1

Device for applying an embossing
to a web of tissue paper

Field of the Invention

The invention relates to an embossing device for embossing a single-ply or multi-ply web of tissue paper.

Technical Background

It is generally known that an embossing pattern on a web of tissue paper is applied using one or more steel rolls in combination with rubber rolls. The rubber rolls have a yielding surface which is elastically pressed by a raised embossing pattern on the steel roll. Tissue paper fed between the rubber roll and the steel roll is imparted with an embossing pattern into the sheet.

It is desired to combine a high degree of softness, which contributes to a good feeling for the user, with an appealing aesthetic appearance of the tissue paper. Therefore, a combination of different embossing patterns can be used. An embossing pattern with a regular arrangement of small protuberances in the embossed tissue paper contributes to a voluminous and soft feeling of the embossed paper, whereas the addition of an embossed aesthetic pattern serves to improve the aesthetic appearance.

There is a constant desire to obtain a good visual appearance of the graphic embossing pattern against a background pattern of rather densely distributed protuberances.

US 4,320,162 describes a method for fabricating a multiple fibrous sheet structure in which each web is embossed with a first pattern embossment and a second pattern embossment, having different heights. The individual embossed webs are

adhesively joined only in those portions of the embossments with greater height. The provision of greater height to the graphic embossments imparts a better visibility against the background pattern of smaller embossments. In addition, these so-called double-depth embossments are said to enhance the softness, the water retention and the bulk of a two-ply web.

EP 0 797 705 B1 describes an embossed paper sheet having first protuberances and second protuberances which are arranged according to a first and second pattern respectively. The first pattern is a graphic pattern sparingly distributed on the surface of the embossed paper sheet, whereas the second embossing pattern forms the background pattern distributed in a high concentration per surface area of the embossed paper sheet. The graphic embossing pattern is formed by protuberances which have a summit surface of linear form. This choice of distribution and form of the protuberances of the graphic embossing pattern and background pattern serves to improve the aesthetic appearance of the embossed paper sheet. The tissue paper plies are embossed in the nip between a metal edged roll and a rubber roll. The projecting elements on the metal roll forming the graphic and background pattern respectively can differ in height. The projecting elements forming the background pattern are lower than those projecting elements forming the graphic pattern.

All the above cited prior art documents relate to technical solutions which can serve to enhance the visibility of a graphic pattern applied to a tissue paper web in addition to that of a background pattern.

US 5,269,983 relates to a rubber-to-steel mated embossing which uses a resilient roll in which recesses are formed. These laser cut recesses receive protrusions of a rigid male embossing roll when the rolls are placed in contact. Due to

the indentations in the rubber roll, significantly less pressure is required between the rubber roll and the rigid roll for causing the rubber to press the web around the protrusions and against the land areas of the rigid roll. This reduces the wear of the rubber.

Summary of the invention

It is the object of the invention to provide an embossing device which improves the visual appearance of a specific embossing pattern of embossed tissue paper.

This objective is solved by an embossing device with the features of claim 1.

It is the underlying principle of the invention to use a conventional pair of rolls for the embossing, namely a steel roll with embossing protuberances on its peripheral surface and a second roll with a yielding layer on its peripheral surface cooperably disposed with respect to the steel roll as to form an embossing nip therewith. The steel roll and the second roll with the yielding layer run in synchronisation. The embossing device is characterised in that the second roll has discrete zones on its peripheral surface with a different thickness of the yielding layer and/or different characteristics of the yielding layer compared to that of the remaining peripheral surface.

The yielding layer of the second roll can be, for example, thicker in those zones which in the embossing nip are opposing to the protuberances forming the graphic pattern. This improves the visibility of the graphic pattern and intensifies the graphic appearance even though the height of the protuberances of the graphic pattern and the background pattern are the same. Therefore, the production of the steel embossing roll with an edged metal surface remains relatively simple because the height of the protrusions on the peripheral surface of the metal embossing cylinder are

identical to those protuberances forming the background pattern and to those forming the décor pattern.

The second possibility is to change the material characteristics of the yielding layer in the discrete zones which, in the embossing nip, are opposed to the embossing protuberances of the steel roll.

The material characteristics of the yielding layer are mainly responsible for the appearance of the embossing pattern so that the choice of different material characteristics of the yielding layer gives the possibility of influencing the deformation of the paper web in the embossing nip and the resulting aesthetic appearance. Wherein the first mentioned possibility of providing the yielding layer with a greater thickness in the discrete zones influences the outer shape of the second embossing roll, the provision of different material characteristics does not change the outer shape of the second roll. It should be noted that the provision of a bombage of the rolls, which is used to compensate a certain sagging of the rolls, is not to be interpreted as discrete zones with a greater thickness because those zones are not specifically opposed to certain embossing protuberances of the steel counter-roll.

The individual zones can have exactly the same shape as the embossing protuberances of the steel roll. It is, however, also possible to follow only the general shape of the embossing protuberances or to place the zones roughly opposed to the embossing protuberances of the counter roll. For complex geometries of the protuberances, an approximately opposed position of the individual zones might be the only feasible way to achieve the desired results without incurring high costs for the manufacturing of the second roll.

Preferred embodiments of the invention are characterised by the dependent claims.

According to the preferred embodiment of the invention, the steel roll has first embossing protrusions forming a graphic pattern and second embossing protrusions forming a background pattern wherein the height of the first embossing protrusions and the height of the second embossing protrusions are identical. As outlined above, the provision of protrusions, all having the same height, makes it easier to produce the steel rolls and in turn reduces the overall costs for the embossing device.

In a preferred embodiment, the synchronisation of the steel roll and the second roll, preferably a rubber coated roll, places the discrete zones of the rubber coated roll opposing to the first protuberances forming a graphic pattern. During the embossing of a paper web, a graphic pattern is produced which has a better visibility and visual appearance than the second background pattern. However, the inventive device can also be used to accentuate the background pattern over the graphic pattern by it becoming less pronounced and less visible. However, under normal circumstances, an improvement in the aesthetic appearance of the graphic pattern is desired.

According to a preferred embodiment of the invention, the second roller has an additional yielding layer in the discrete zones of its peripheral surface. In other words, there is a first yielding layer, e.g. a rubber layer, covering the whole peripheral surface of the second roll and, on top of it, a second yielding layer covering only the discrete zones.

According to a further preferred embodiment, the additional yielding layer has a different hardness compared to that of the yielding layer. For example, it is possible to provide an additional yielding layer with a lower rubber hardness

than that of the yielding layer covering the remaining part of the peripheral surface of the second roll.

The provision of different material characteristics is not only possible in combination with a higher overall thickness of the second roll. It is also possible to produce a second roll which is covered by a yielding layer with discrete zones, the material characteristics of which are different. Alternatively, the second roll can be provided with a yielding layer of uniform thickness which undergoes a surface treatment which is either only applied to the discrete zones or applied to the remaining surface. Thus, the different material characteristics can either be generated by using a different material composition or by using a different surface treatment.

Brief Description of the Drawings

In the following the invention is described by way of example only. With reference to the accompanying drawings, in which:

Fig. 1 shows first embodiment of the embossing device according to the invention; and

Fig. 2 shows a sectional detail view of the surface layer of a rubber embossing roll.

Detailed Description of Preferred Embodiments

In the following description of preferred embodiments of the invention, corresponding parts or elements in the different drawings will be denoted by the same reference numerals. In the schematic drawing according to Fig. 2, the height of the yielding surface layers was selected to clarify the invention and is not drawn to scale.

Fig. 1 shows part of an embossing station comprising two cylindrical rolls, a steel embossing roll 12 and a rubber roll 14, both of which rotate around parallel rotational axes 16 and 18. The steel embossing roll 12 and rubber roll 14 are arranged so that an embossing nip 20 is formed between the rolls. Both rolls 12 and 14 are part of an embossing station, the periphery of which is not shown in Fig. 1. In order to ensure that the rubber roll 14 runs in exact registration with the steel embossing roll 12, both rolls are provided with a geared portion around their circumference which mesh with each other so that, within the negligible play of meshing gears, the rubber roll runs in synchronisation with a steel embossing roll.

On the steel embossing roll, there are first and second protrusions which are only sketched on part of its peripheral surface. There are the first protrusions 24 which form a graphic pattern to be embossed on a single-ply or multi-ply web of tissue paper running through the nip 20. In the example case according to Fig. 1, the first protrusions have the shape of feathers, however, any décor can be used given that the first protrusions are for aesthetic purposes only. The first protrusions 24 cover a considerably larger surface area than the second protrusions 26 which serve to impart a background embossing to the tissue paper web to be embossed. The second protrusions are of a much smaller surface area than the first protrusions and have a simple geometrical shape like truncated cones, truncated pyramids or similar shapes. The first protrusions are evenly distributed over the whole peripheral surface of the steel embossing roll 12 and are only left out in those parts of the steel embossing roll where the first protrusions with the graphic décor are placed.

The rubber roll 14 is synchronised and in registration with the steel embossing roll 12 and has a flexible and yielding surface. The rubber roll serves to squeeze the web running

through the nip against the male protrusions of the steel embossing roll and accommodate the protrusions of the steel embossing roll by virtue of its resilience. The yielding rubber layer on the rubber roll flows about the protrusions of the steel embossing roll as force is applied to bring the rolls together.

As indicated by the dotted line 28 in Fig. 1, the rubber roll 14 has a core of any suitable material which is covered by a surface layer of rubber.

According to the embodiment of the invention shown in Fig. 1, the rubber layer of the rubber roll has different Shore-A-values on its peripheral surface. In the embodiment depicted in Fig. 1, there are individual zones 30 on the peripheral surface of the rubber roll 14 which, as indicated by a comparison of their position with regard to the first protrusions 24 on the outer surface of the steel embossing roll, are arranged to be opposed to the first protrusions in the nip 20 between both rolls. Therefore, during the operation and synchronised rotation of the steel embossing roll 12 and rubber roll 14, the tissue paper web, which is to be embossed between both rolls, comes into contact with the individual zones 30 of the rubber roll where on the other side of tissue paper web there are the first protrusions 24. Therefore, the individual zones 30 and the first protrusions 24 cooperate in the embossing nip. In the example case shown in Fig. 1, the individual zones 30 have a rubber hardness of 55 Shore-A whereas the remaining surface area of the rubber roll has a yielding rubber coating with a hardness of 80 Shore-A. The softer surface zones 30 cooperate with the first protrusions 24 such that a more pronounced and sharper graphic embossing can be obtained.

Preferably, the height of the first protrusions 24 and the second protrusions 26 is identical. In practical terms, individual zones in the rubber roller which have a higher

degree of hardness are favoured with regard to the visibility of a graphic pattern. However, there might be tissue paper which is sensitive to mechanical load. In this instance, it is quite possible that individual zones with a lower degree of rubber hardness be preferred in order to improve the visual appearance of a graphic pattern.

In general, the rubber hardness of the surface layer of the rubber roll 14 can vary between 25 to 100 Shore-A. However, the preferred range is between 45 and 80 Shore-A.

According to another embodiment of the invention, the rubber roll 14 might be provided with elevated surface areas corresponding to the individual zones 30 shown in Fig. 1. These elevated surface areas have a similar effect to the provision of individual zones 30 in Fig. 1 with a higher degree of rubber hardness. In these elevated zones, there is a higher pressure between the steel embossing roll 12 and the rubber roll 14 so that the first protrusions are pressed into the tissue paper web resulting in a good visibility of the graphic pattern.

Fig. 2 discloses a sectional view of a part of the rubber roll 14 with a first rubber layer 32 and a second rubber layer 34 in the individual zones 30 which come into contact with the first protrusions on the synchronised steel embossing roll. The second rubber layer 34 can have the same or a different rubber hardness depending on the specific requirements, the tissue material to be embossed and the shape and density of the protrusions.

In general, the use of a different material in the individual zones 30 and, alternatively or in combination, the possible provision of elevated areas in these zones opens up the possibility of adjusting the optimum visibility of different embossing patterns having the same height on the corresponding steel embossing roll.

Claims

1. An embossing device for embossing a single-ply or multi-ply web of tissue paper, comprising

a steel roll (12) with embossing protuberances (24, 26) on its peripheral surface; and

a second roll (14) with a yielding layer (32) on its peripheral surface cooperably disposed with respect to the steel roll (12) as to form an embossing nip (20) therewith; wherein

the steel roll (12) and the second roll (14) run in synchronisation;

characterised in that

the second roll (14) has individual zones (30) on its peripheral surface with a higher overall thickness and/or different material characteristics of the yielding layer (32; 32, 34) compared to that of the remaining peripheral surface; wherein

the individual zones (30) are generally opposed in the embossing nip (20) to embossing protuberances (24) of the steel roll.
2. Embossing device according to claim 1, characterised in that the steel roll has first embossing protrusions (24) forming a graphic pattern and second embossing protrusions (26) forming a background pattern, the height of the first embossing protrusions (24) and the second embossing protrusions (26) being identical.

3. Embossing device according to claim 1 or 2, characterised in that the second roll (14) is a rubber coated roll.
4. Embossing device according to any of the claims 1, 2, 3, characterised in that the synchronisation of the steel roll (12) and the second roll (14) places the individual zones (30) of the second roll (14) opposing to the first protuberances (24).
5. Embossing device according to any of the claims 1 to 4, characterised in that the second roll (14) has an additional yielding layer (34) in the individual zones (30) of its peripheral surface.
6. Embossing device according to claim 5, characterised in that the additional yielding layer (36) has a different hardness compared to the yielding layer (34) in the remaining part of the peripheral surface.
7. Embossing device according to any of the claims 1 to 4, wherein the yielding layer of the individual zones (30) has a different material composition and/or surface treatment compared to the yielding layer of the remaining part of the peripheral surface.

Fig. 1

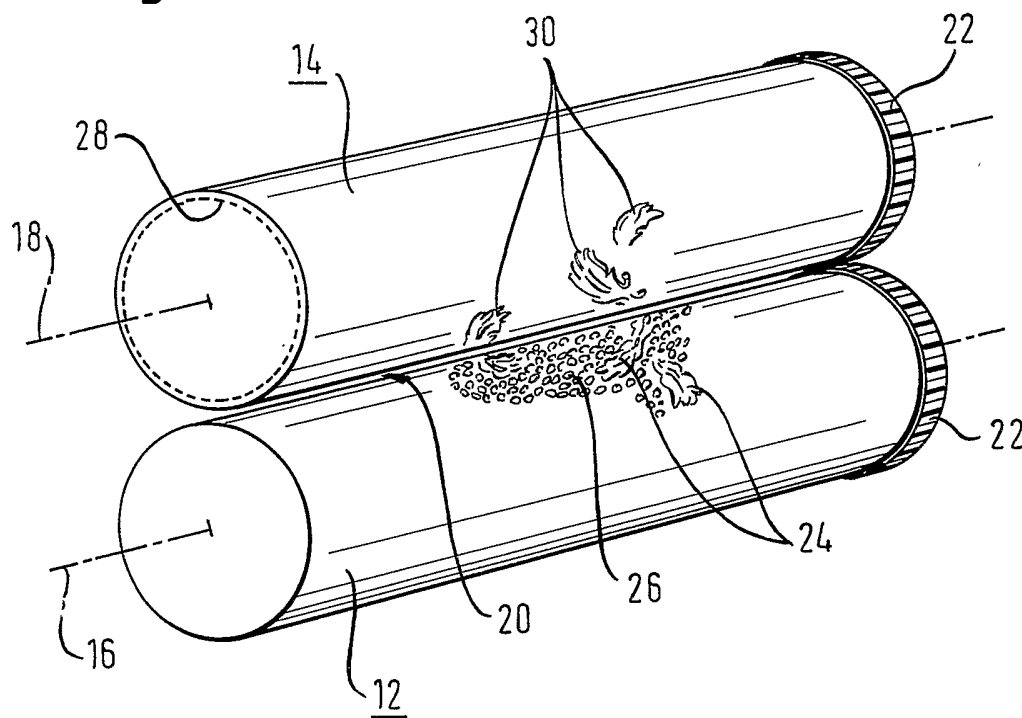
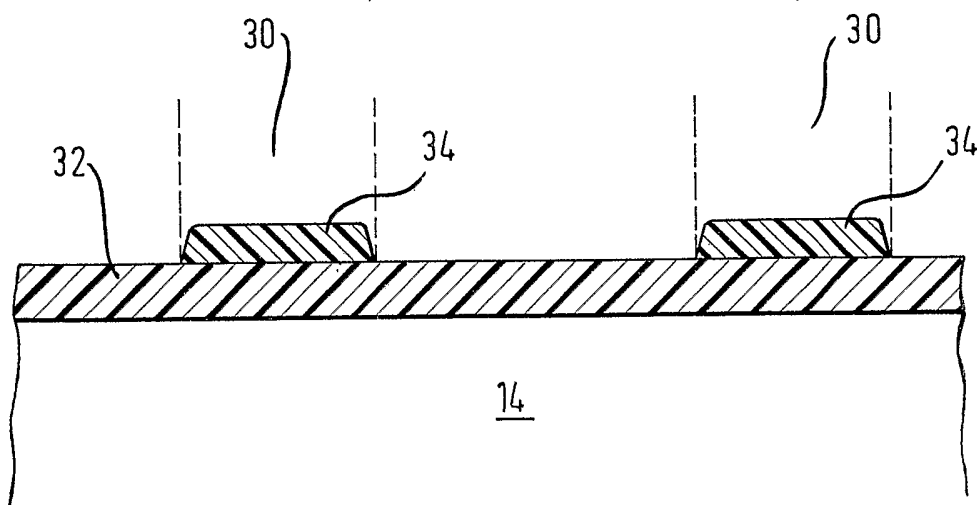

Fig. 2



INTERNATIONAL SEARCH REPORT

International Application No

PCT/EP 02/04460

A. CLASSIFICATION OF SUBJECT MATTER
IPC 7 B31F1/07

According to International Patent Classification (IPC) or to both national classification and IPC

B. FIELDS SEARCHED

Minimum documentation searched (classification system followed by classification symbols)
IPC 7 B31F

Documentation searched other than minimum documentation to the extent that such documents are included in the fields searched

Electronic data base consulted during the international search (name of data base and, where practical, search terms used)

WPI Data, PAJ, EPO-Internal

C. DOCUMENTS CONSIDERED TO BE RELEVANT

Category *	Citation of document, with indication, where appropriate, of the relevant passages	Relevant to claim No.
X	PATENT ABSTRACTS OF JAPAN vol. 018, no. 452 (M-1661), 23 August 1994 (1994-08-23) & JP 06 143466 A (YURI ROLL KK), 24 May 1994 (1994-05-24) abstract	1, 3, 4
A	US 5 269 983 A (SCHULZ GALYN A) 14 December 1993 (1993-12-14) cited in the application the whole document	1-7
A	US 6 106 928 A (RUPPEL REMY ET AL) 22 August 2000 (2000-08-22) cited in the application abstract; figures	2
	-/--	



Further documents are listed in the continuation of box C.



Patent family members are listed in annex.

* Special categories of cited documents:

- *A* document defining the general state of the art which is not considered to be of particular relevance
- *E* earlier document but published on or after the international filing date
- *L* document which may throw doubts on priority claim(s) or which is cited to establish the publication date of another citation or other special reason (as specified)
- *O* document referring to an oral disclosure, use, exhibition or other means
- *P* document published prior to the international filing date but later than the priority date claimed

- *T* later document published after the international filing date or priority date and not in conflict with the application but cited to understand the principle or theory underlying the invention
- *X* document of particular relevance; the claimed invention cannot be considered novel or cannot be considered to involve an inventive step when the document is taken alone
- *Y* document of particular relevance; the claimed invention cannot be considered to involve an inventive step when the document is combined with one or more other such documents, such combination being obvious to a person skilled in the art.
- *G* document member of the same patent family

Date of the actual completion of the international search

1 July 2002

Date of mailing of the international search report

09/07/2002

Name and mailing address of the ISA

European Patent Office, P.B. 5818 Patentlaan 2
NL - 2280 HV Rijswijk
Tel. (+31-70) 340-2040, Tx. 31 651 epo nl,
Fax: (+31-70) 340-3016

Authorized officer

J-E. Söderberg

INTERNATIONAL SEARCH REPORT

International Application No

PCT/EP 02/04460

C.(Continuation) DOCUMENTS CONSIDERED TO BE RELEVANT		
Category *	Citation of document, with indication, where appropriate, of the relevant passages	Relevant to claim No.
A	US 4 320 162 A (SCHULZ GALYN A) 16 March 1982 (1982-03-16) cited in the application -----	
A	US 5 415 918 A (MARTIN DAVID J ET AL) 16 May 1995 (1995-05-16) -----	
A	EP 1 033 240 A (IND CARTARIE TRONCHETTI SPA) 6 September 2000 (2000-09-06) -----	

INTERNATIONAL SEARCH REPORT

Information on patent family members

International Application No

PCT/EP 02/04460

Patent document cited in search report		Publication date	Patent family member(s)	Publication date
JP 06143466	A	24-05-1994	NONE	
US 5269983	A	14-12-1993	CA 2060567 A1 DE 69223822 D1 DE 69223822 T2 EP 0498623 A2 ES 2110468 T3	05-08-1992 12-02-1998 23-04-1998 12-08-1992 16-02-1998
US 6106928	A	22-08-2000	FR 2728152 A1 AT 188266 T CA 2202166 A1 DE 69514253 D1 DE 69514253 T2 DK 797705 T3 EP 0797705 A1 ES 2141977 T3 WO 9618771 A1 GR 3032544 T3 NO 972763 A PT 797705 T	21-06-1996 15-01-2000 20-06-1996 03-02-2000 08-06-2000 08-05-2000 01-10-1997 01-04-2000 20-06-1996 31-05-2000 16-06-1997 28-04-2000
US 4320162	A	16-03-1982	US 4376671 A	15-03-1983
US 5415918	A	16-05-1995	CA 2138692 A1 DE 69417392 D1 DE 69417392 T2 EP 0674990 A2 ES 2131625 T3	23-06-1995 29-04-1999 15-07-1999 04-10-1995 01-08-1999
EP 1033240	A	06-09-2000	EP 1033240 A1 US 2002023708 A1	06-09-2000 28-02-2002