

(No Model.)

2 Sheets—Sheet 1.

J. N. SCHWALEN.
AUTOMATIC VEHICLE BRAKE.

No. 460,892.

Patented Oct. 6, 1891.

Fig. 1.

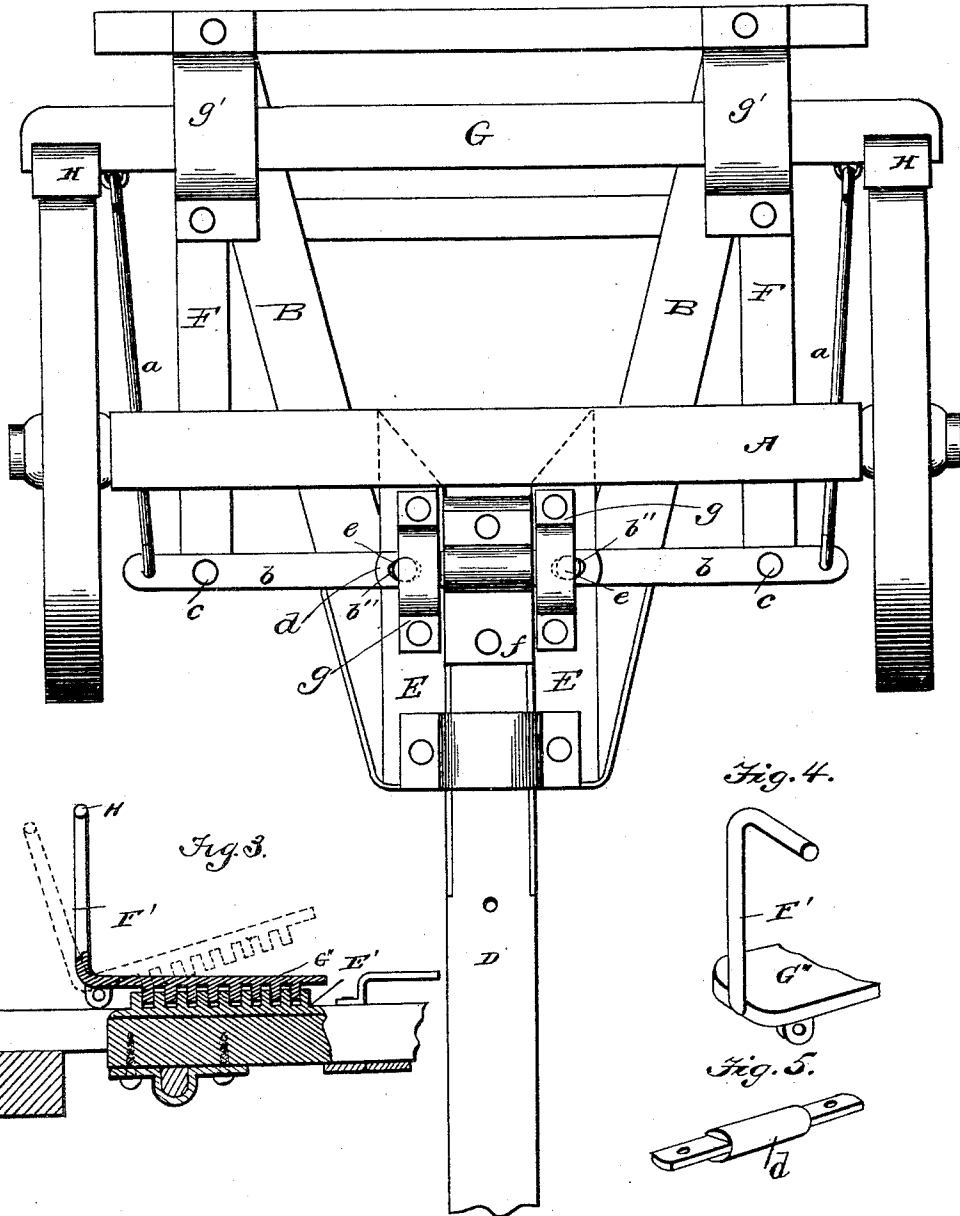

Witnesses

W. H. Schieff
W. J. Palmer

John N. Schwalen Inventor
 By *Chas. E. Barber* Attorney

(No Model.)

2 Sheets—Sheet 2.

J. N. SCHWALEN.
AUTOMATIC VEHICLE BRAKE.

No. 460,892.

Patented Oct. 6, 1891.

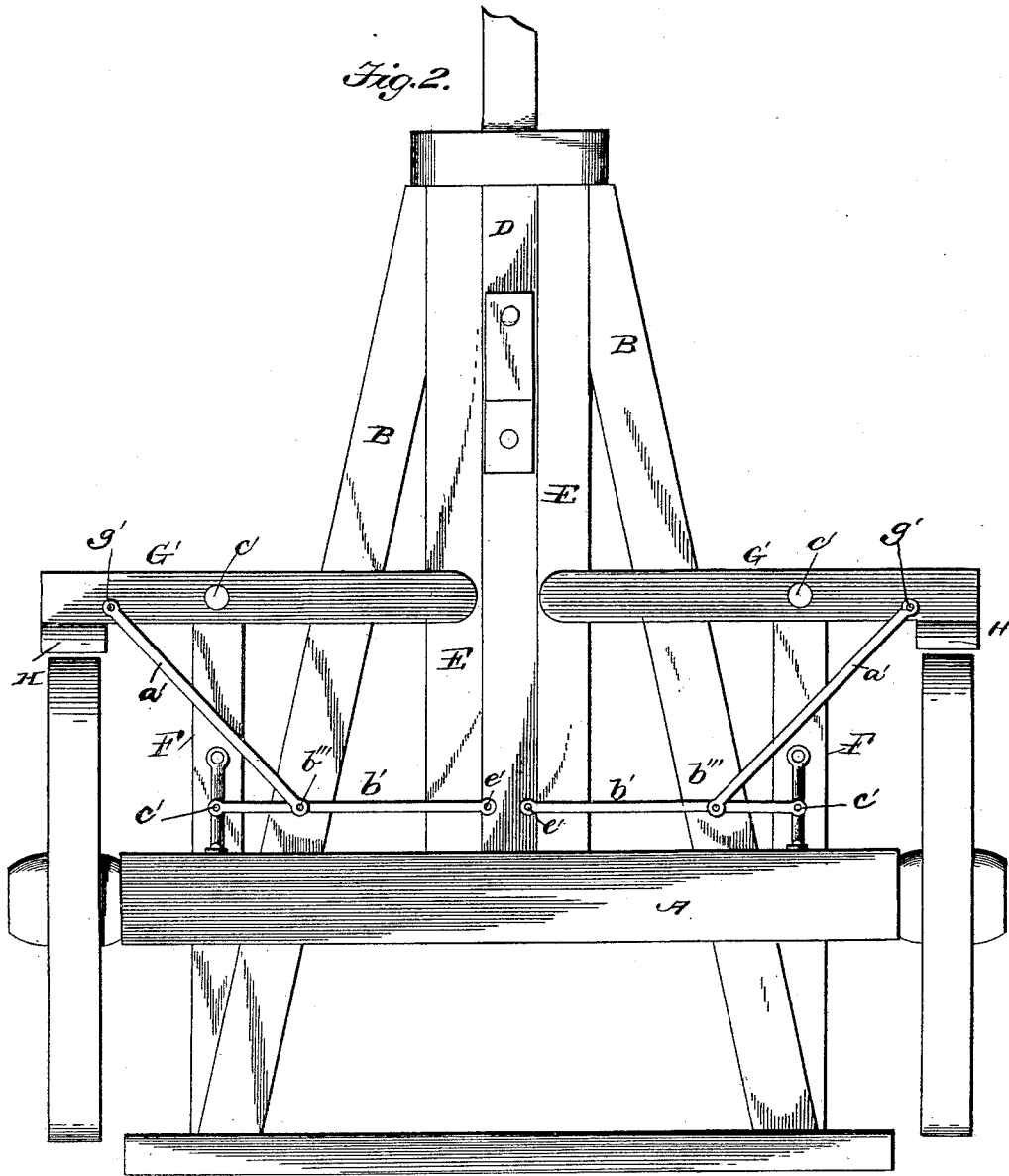

Witnesses:

W. F. Palmer
W. F. Palmer

Inventor:

John N. Schwalen
By *Chas. W. [unclear]*
Attorney

UNITED STATES PATENT OFFICE.

JOHN N. SCHWALEN, OF HUDSON, WISCONSIN, ASSIGNOR OF ONE-HALF TO
LEO KNOTT, OF SAME PLACE.

AUTOMATIC VEHICLE-BRAKE.

SPECIFICATION forming part of Letters Patent No. 460,892, dated October 6, 1891.

Application filed October 24, 1890. Serial No. 369,206. (No model.)

To all whom it may concern:

Be it known that I, JOHN N. SCHWALEN, a citizen of the United States, residing at Hudson, in the county of St. Croix, in the State of Wisconsin, have invented certain new and useful Improvements in Wagon-Brakes, of which the following is a full and complete description, sufficient to enable any one having ordinary mechanical skill to make and use the same.

My invention relates to automatic brakes which are applied by the team holding back, as when going downhill, and taken off by the draft of the team when the bottom of the hill is reached; and it consists in the construction, arrangement, and combination of devices, hereinafter described, and specifically pointed out in the claim.

In the accompanying drawings, which illustrate my invention and form a part of this specification, Figure 1 is a bottom plan view of the front part of the running-gear of a wagon, showing the brakes applied to the rear of the wheels. Fig. 2 is a similar view showing the brakes applied in front of the wheels. Fig. 3 is a vertical sectional view taken longitudinally through the rear end of the tongue, showing the devices for holding the tongue in fixed position. Figs. 4 and 5 are views showing details.

I will first describe the arrangement shown in Fig. 1, and afterward that shown in Fig. 2.

A designates the axle, B B the hounds, and D the tongue. The tongue is not provided with the usual hounds, but is merely a straight pole, the rear end of which lies and works between two parallel cheek-pieces E E, secured at their front ends to the hounds B B and at their rear ends to the axle. The tongue is secured in place by a transverse bar or bolt *d*. Ordinarily the bolt *d* passes through the tongue and hounds; but, as represented in the drawings, it passes under the tongue, being held to the latter by a metal plate *f*, bent to form a keeper and secured against the under side of the tongue. The ends of the bolt *d* are flattened and project into keepers formed of flat plates *g g*, bolted against the under sides of the cheek-pieces E E. The keepers *g g* are of such length as to permit a limited reciprocating movement of the tongue, the pur-

pose of which will presently be explained. Outside of the hounds are two longitudinal side bars F F, substantially parallel to each other, their rear ends bolted against the sides of the hounds and their front ends upon the axle. They project somewhat in front of the axle, as shown. Upon the front ends of the side bars F F, at *cc*, are fulcrumed two transverse levers *b b*, whose inner ends are pivotally connected with the flattened ends of the bolt *d*, the pivot-holes *b''* in the latter being sufficiently elongated to permit the vibration of the levers *b b* by the backward and forward movement of the tongue and bolt *d*.

The levers *b b* are connected by connecting rods or links *a a* with the brake-bar G, which is held against the under side of the hounds B B by keepers *g' g'*, of sufficient length to permit the necessary forward and backward movement of the brake-bar to apply the brakes H H to the wheels and to take them off.

The operation of this brake mechanism is as follows: When the wagon is going downhill and the horses are holding back, the tongue will move back, carrying with it the bolt *d*, whereby the levers *b b* will be vibrated on their fulcra *cc*, the brake-bar G will be drawn forward by the connecting-rods *a a*, and the brakes will be pressed against the wheels with a force corresponding with or depending on the weight of the load, the steepness of the hill, and the force with which the team holds back.

Referring now to Fig. 2 of the drawings, which shows the brakes arranged in front of the wheels, the construction, arrangement, and operation are described as follows: Instead of the single and continuous brake-bar G, above described, I use two short bars G' G', which, instead of sliding, as before, are pivoted on the front ends of the side bars F F, which extend forward past the rims of the wheels, as shown, so that the brake-blocks H H, on the outer ends of the bars G' G' stand in front of the wheels. Transverse levers *b' b'* are fulcrumed at *c' c'* on the side bars F F in front of the axle, their inner ends being pivotally connected to the tongue at *e'*, so as to be swung backward and forward by the backward and forward movement of the tongue. The levers *b'* are connected at

points b''' inside of their fulera with the brake-bars G' , at points g' outside of their pivots c' by connecting-rods a' , whereby when the levers b' are swung backward the outer ends of the bars G' will also be drawn backward and the brake-blocks pressed against the wheels, and when swung forward the corresponding movement thereby imparted to the bars G and to the brake-blocks will carry the latter away from the wheels.

It is sometimes desirable to hold the brakes in or out of action, and for this purpose I employ the devices illustrated in Figs. 3 and 4 of the drawings, the construction, arrangement, and operation of which are as follows: On the upper side of the tongue D at the rear end thereof is arranged a toothed plate E' , and on the cheek-pieces E E is pivoted a correspondingly-toothed plate G'' , the teeth of which, when in the position shown in full lines in Fig. 3, engage the teeth of the plate E' and hold the tongue in fixed position against either forward or backward movement, and thus hold the brakes in or out of action, according to the position in which the tongue is locked. When, however, the plate G'' is turned up into the position indicated by broken lines the tongue is free to be moved backward and forward to operate the brakes,

as above explained. The plate G'' is provided with a vertical lever-arm F' , bent laterally at its upper end, whereby it is adapted to be operated by the foot of the driver.

It will be understood that a single tooth on each of the plates E' and G'' would be sufficient to hold the tongue in either of its two positions; but for the sake of strength and security I provide a series of teeth, as shown.

Having now described my invention, I claim—

In an automatic vehicle-brake adapted to be operated by the longitudinal movement of the tongue, the combination, with the tongue provided on its upper side with a toothed rack or plate E' , of a correspondingly-toothed plate G'' , pivoted on the frame of the vehicle and provided with a vertical lever-arm bent laterally at its upper end, whereby it is adapted to be operated by the foot of the driver to throw the said toothed plates into and out of engagement, substantially as shown and described.

In testimony whereof I affix my signature in presence of two witnesses.

JOHN N. SCHWALEN.

Witnesses:
ROBT. DINSMORE,
JOHN PADDEN.