

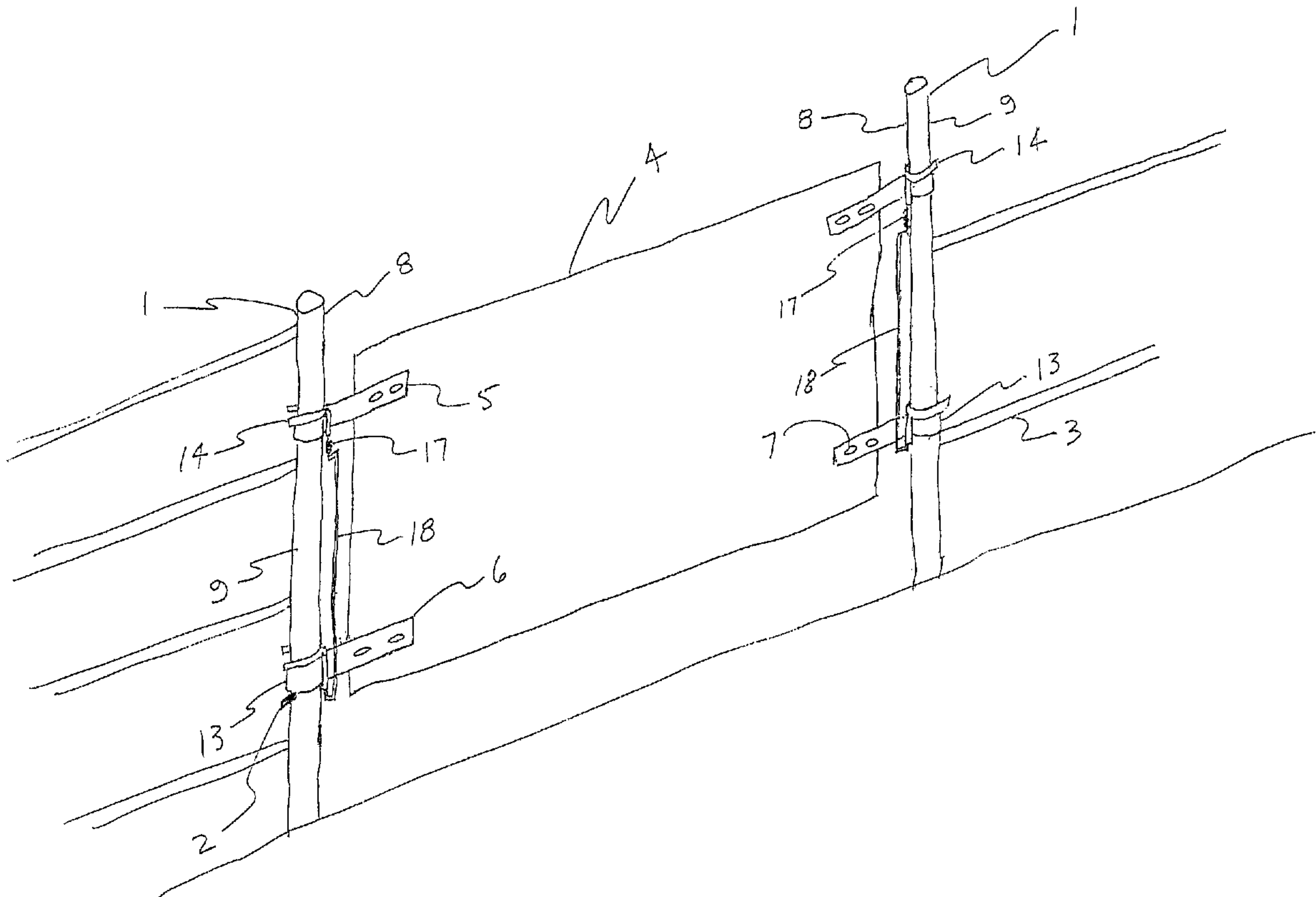

(22) Date de dépôt/Filing Date: 1998/09/30
(41) Mise à la disp. pub./Open to Public Insp.: 2000/03/30
(45) Date de délivrance/Issue Date: 2003/11/04

(51) Cl.Int.⁶/Int.Cl.⁶ E06B 11/04, E05D 15/50
(72) Inventeurs/Inventors:
AKINS, ALLAN, CA;
KUFFNER, JOE, CA;
PETERS, LEN, CA
(73) Propriétaire/Owner:
HI-QUAL MANUFACTURING LTD., CA
(74) Agent: FURMAN & KALLIO

(54) Titre : PORTAIL A DEUX SENS
(54) Title: TWO-WAY GATE



(57) Abrégé/Abstract:

The invention provides a gate operable from either end thereof, as well as a hardware kit for the conversion of existing gates. The two way gate of the present invention is simpler to operate and more rugged than those known in the art.

ABSTRACT

5 The invention provides a gate operable from either end thereof, as well as a hardware kit for the conversion of existing gates. The two way gate of the present invention is simpler to operate and more rugged than those known in the art.

- Page 1 -

TWO-WAY GATE

5 This invention deals with the field of gates for closing an opening in a wall, fence or so forth, and in particular with such a gate that hinges and latches on both ends.

10 **BACKGROUND**

The value of two-way gates that will both hinge and latch on each side is well known. Examples of such prior gates are disclosed in United States Patent Numbers 3,300,898 to Etnyre;
15 3,030,717 to Lewis; 2,822,630 to Guyer and 1,505,039 to Lay.

The devices disclosed in these patents all provide the advantages that they may be opened from either side, and in fact in either direction from either side, and can be
20 completely removed easily. There however are disadvantages associated with each.

- Page 2 -

It is a distinct advantage to be able to simply push or slam a gate closed and have it latch in place automatically. Only the gate of Guyer may, in one embodiment, be closed by simply pushing or slamming the gate closed. All the others require
5 relatively precise placement of the gate relative to the gate post, and subsequent manual lifting or latching. In the Gruyer embodiment, when the gate is slammed a hole in a bracket falls over a pin. The embodiment incorporates a fairly complex linkage wherein tolerances must be kept within
10 a limited range. Because of the need to maintain these tolerances, the embodiment would not be suitable for the rough treatment many gates, especially those for use with livestock, are subjected to.

15 This rough treatment often results in bent and deformed gates or gate posts. None of the prior art gates provide any adjustment to allow the working parts to be adjusted to compensate for deformed gates or gate posts.

20 Only the gate of Lay does not require hinge parts projecting from the fixed sides of the opening when the gate is open. These projecting parts are dangerous to persons, vehicles,

- Page 3 -

livestock and so forth passing through the gate. While the Lay gate has no such projecting parts, it leaves an open hole in the ground when the gate is open, which is also dangerous. This hole is also liable to be filled with soil, snow and so forth unless the socket pipe defining the hole is raised which would again present a danger to traffic passing through the gate.

Only the gate of Lay may slide vertically up to a certain degree and still function properly. This ability is an advantage where snow or such might block a gate.

SUMMARY OF THE INVENTION

It is an object of the present invention to provide a gate that may be opened from either end.

It is a further object of the present invention to provide such a gate that leaves no projections inside the gate post when the gate is open.

It is a further object of the present invention to provide

- Page 4 -

such a gate that may will latch closed automatically when pushed into a closed position.

The invention accomplishes these objects providing a gate operable so as to open from either end thereof, said gate comprising an opening defined on each side by a vertical column, said vertical columns defining vertical cylinders at portions thereof, said vertical cylinders having inner sides facing each other across the width of the opening, and outer sides opposite said inner sides; a gate panel having two ends and two sides; a fixed U-shaped top hinge member extending from an upper portion of each end of said gate panel and a fixed U-shaped bottom hinge member extending from a lower portion of each end of said gate panel such that the open ends of said U-shaped hinge members are aligned towards one side of said gate panel and aligned with said vertical cylinders such that when said gate is closed each said U-shaped hinge member engages said vertical cylinders such that a first leg thereof lies on said inner side of one of said vertical cylinders, substantially perpendicular to said opening and the second leg thereof lies on said outer side of one of said vertical cylinders, substantially perpendicular to said opening; a

- Page 5 -

support member extending radially from each said vertical cylinder such that the bottom edge of one said hinge member on each end of said gate is supported thereby when that end of said gate is closed; a U-shaped latch member pivotally
5 attached about a vertical axis to each end of said gate panel such that said latch members may pivot from a closed position engaging said vertical cylinders such that the legs of said latch members are perpendicular to the legs of said hinge members, thereby securing said hinge members to said vertical
10 cylinders, to an open position wherein said legs of said latch members are at an acute angle to said legs of the hinge members, thereby releasing said hinge members to be moved away from said vertical cylinders; controls to selectively
lock said latch members into said closed position and to
15 release said latch members, allowing said latch members to pivot into said open position.

Such a gate would not be operable to swing in or out, but could be easily removed by unlatching both ends and put in
20 position so as to swing the opposite direction if so desired, for example into a pen instead of out of the pen. Such a gate would provide a passage way through the open gate with no

- Page 6 -

projections into same or other hazards such as a hole in the ground. Such a gate would also freely move up on the vertical cylinders to avoid obstructions.

5 The control could comprise biasing means to lock the latch member into the closed position when the legs of the latch member are pivoted into the closed position. The pivotal attachment of the latch members to the ends of the gate panel could comprise a vertical pin fixed to the closed end of the
10 U of each the latch member, the pin engaging a vertical aperture defined by a member fixed to the gate panel, the pin and latch member thereby free to rotate and to move vertically in the aperture, the latch member thus being able to pivot from a closed to an open position.

15 The controls could comprise a block fixed to the gate panel such that when the latch member is in the closed position, the latch member is held in a bottom vertical position by the biasing means wherein the block prevents pivoting of the
20 latch member. Raising means could be provided to raise the latch member against the biasing force to an upper vertical position wherein the latch member may pivot over the top of

- Page 7 -

the block and rest on the block in the open position when the raising means is released. In this way, when the gate is pushed shut or slammed, the latch member will pivot into the closed position as it contacts the vertical cylinder, and be pushed down into the closed and latched position by the biassing force, thus providing a gate that latches closed automatically when slammed..

To provide maximum strength, a latch member could be provided vertically adjacent to each the hinge member. The controls could comprise a vertical lifting member joining the latch members on each end of the gate panel, thereby simultaneously raising both such latch members so they would be free to pivot over the blocks into an open position, thereby allowing the hinge members to move away from the vertical column and the gate to open.

Conveniently, the vertical apertures could be defined by the hinge members and the blocks could be fixed to the top of the hinge members.

The fixed position of the U of the hinge members relative to

- Page 8 -

the gate panel could be adjustable closer to or farther from the gate panel, thereby allowing accommodation for bent or deformed gates.

5 The support members could extend from the outer sides of the vertical cylinders, thereby supporting the hinge member as it rotates on the vertical cylinder when the gate is swung open from the opposite end without risk of the open end of the hinge U aligning with the support member, at which point the
10 gate would slide down the vertical cylinder. This position also keeps the inner sides of the vertical cylinders free from projections. Rails attached to the vertical cylinders as part of a fence could conveniently serve as support members.

15 The hinge members, latch members, support members and controls could conveniently be supplied in a kit for installation on a gate.

In another aspect the invention provides a gate operable so as
20 to open from either end thereof, said gate comprising an opening defined on each side by a vertical column, said vertical columns defining vertical cylinders at portions

- Page 9 -

thereof, said vertical cylinders having inner sides facing each other across the width of the opening, and outer sides opposite said inner sides; a vertically planar gate panel having a first end and a second end and further having a first
5 side and a second side; a fixed U-shaped top hinge member extending from an upper portion of each end of said gate panel and a fixed U-shaped bottom hinge member extending from a lower portion of each end of said gate panel such that the open ends of said U-shaped hinge members are aligned towards
10 one side of said gate panel and aligned with said vertical cylinders such that when said gate is closed each said U-shaped hinge member engages said vertical cylinders such that a first leg thereof lies on said inner side of one of said vertical cylinders, substantially perpendicular to said
15 opening and the second leg thereof lies on said outer side of one of said vertical cylinders, substantially perpendicular to said opening; a support member extending radially from each said vertical cylinder such that the bottom edge of one said hinge member on each end of said gate is supported thereby
20 when that end of said gate is closed; a latch operable to lock said U-shaped hinge members into engagement with said vertical cylinders when said gate is closed.

- Page 10 -

The latch could comprise a U-shaped latch member wherein the legs of the U are separated by a vertical distance, the latch member pivotally attached about a vertical axis to each end of the gate panel such that the latch members may pivot from a closed position engaging the vertical cylinders such that the legs of the latch members are perpendicular to the legs of the hinge members, thereby securing the hinge members to the vertical cylinders, to an open position wherein the legs of the latch members may pivot, allowing the hinge members to be moved away from the vertical cylinders. Thus the latch member would act in a similar manner to the U-shaped latch member described above. The fact that one leg of the U was vertically removed from the other would not change the action thereof so long as the legs are fixed with respect to each other.

In a simple embodiment, the latch means could simply comprise a bar operable to close the open end of the U of the hinge member when the hinge member is engaged in the vertical column.

- Page 11 -

DESCRIPTION OF THE DRAWINGS:

While the invention is claimed in the concluding portions
5 hereof, preferred embodiments are provided in the accompanying
detailed description which may be best understood in
conjunction with the accompanying diagrams where like parts in
each of the several diagrams are labeled with like numbers,
and where:

10 Figure 1 is a perspective view of the preferred
embodiment;

Figure 2 is an end view of the hinge member;

15 Figure 3 is a top view of the hinge member of Figure 2;

Figure 4 is a side view of the hinge member of Figure 2;

20 Figure 5 is a top view of the latch member;

Figure 6 is a side view of the latch member of Figure 5;

- Page 12 -

Figure 7 is a top view of the hinge and latch members in the closed position about a vertical cylinder;

Figure 8 is a side view of the hinge and latch members in Figure 7;

Figure 9 is a top view of the hinge and latch members in a partially open position about a vertical cylinder;

Figure 10 is a side view of the hinge and latch members in Figure 9;

Figure 11 is a top view of the hinge and latch members in the open position adjacent to a vertical cylinder;

Figure 12 is a perspective view of an alternate embodiment comprising a single latch member mid-way between the two hinge members at one end of a gate panel;

Figure 13 is a top view of an alternate embodiment wherein the legs of the U-shaped latch member are separated by a vertical distance;

- Page 13 -

Figure 14 is a side view of the embodiment of Figure 13;

Figure 15 is a top view of an alternate embodiment comprising a bar which may pivot to lock the hinge member into engagement with the vertical column.

DETAILED DESCRIPTION OF THE EMBODIMENT

Figure 1 shows a preferred embodiment of the invention. The vertical columns defining the gate opening are vertical cylinders 1. The columns could be any shape but must define vertical cylinders at those points where the hinge members 5, 6 and latch members 14 must pivot around the column. It is therefore most convenient to provide a cylindrical tube for the columns.

Gate panel 4 may be any gate or door mounted in an opening in a fence as shown or in a wall or other structure. U-shaped upper hinge members 5 extend from upper portions of each end of the gate panel 4 and similarly U-shaped lower hinge members 6 extend from lower portions of each end of the gate panel 4. These hinge members 5 and 6 are fixed to the gate panel 4 by

- Page 14 -

bolts through slotted holes 7, thereby allowing them to be adjusted closer to or farther away from the gate panel 4. Thus some degree of bending or deformity of the gate panel 4 or vertical cylinders 1 may be accommodated.

5

It can be seen that the open ends of the hinge U's 13 of the hinge members 5 and 6 are aligned towards one side of the gate panel 4 and also aligned with the vertical cylinders 1 such that when the gate is closed, each hinge U 13 engages a vertical cylinder 1 such that a first leg thereof lies on the inner side 8 of one of the vertical cylinders 1, substantially perpendicular to the opening and the second leg thereof lies on the outer side 9 of one of the vertical cylinders 1, substantially perpendicular to the opening. This can best be seen in Figure 7.

10

15

Figure 1 also illustrates the support member. On the left side of the gate as illustrated, the support member is a support pin 2 extending from the outer side 9 of the vertical cylinder 1. In this position the hinge member will be supported while the gate is opened, without risk of the open end of the hinge U 13 coming into alignment with the support

20

- Page 15 -

pin 2. In this position as well there is the least interference with traffic near the gate.

On the right side of the gate as illustrated, the support member is a fence rail 3 which is part of the fence and also extends from the outer side 9 of the vertical cylinder 1. Thus the support member may be part of the structure of the enclosure where it is convenient. The support member on each side of the gate serves to hold the gate panel 4 in the proper vertical position on the vertical cylinders 1. The gate may move up unless the hinge is obstructed.

Figures 2, 3 and 4 illustrate the hinge members 5 and 6. The hinge U 13 is attached to a hinge bracket 12 which is attached to the gate panel 4 as shown in Figure 1 by bolts through slotted holes 7. Block 10 is welded to the top of each hinge member 5,6 and serves to lock the gate closed as will be shown. Sleeve 11 is welded to the side of the hinge U 13 and serves as the pivot point for the latch as will be shown. The lower side of that leg of the hinge U 13 which rests on the support member is tapered 20 to facilitate the hinge U 13 riding up on top of the support pin 2 or fence rail 3 when the

- Page 16 -

gate is pushed closed.

Figures 5 and 6 illustrate the U-shaped latch member 14, which comprises a latch U 15 welded to a latch pin 16.

5

Figures 7 and 8 illustrate the mechanism engaged about a vertical cylinder 1 in the closed position. The legs of the latch U 15 are substantially perpendicular to the legs of the hinge U 13 thereby providing coverage about three quarters of

10

the circumference of the vertical cylinder 1. The gate panel 4 fixed to the hinge members 5,6 is thereby allowed to rotate about vertical cylinder 1 while being maintained in firm engagement therewith. Thus the opposite end of the gate panel

15

4 may be swung open. The latch pin 16 is engaged in the sleeve 11 where it may freely rotate and move up and down. In the illustrated closed position the latch member 14 is in its lowest position resting on top of the hinge member 5,6, and is locked into the closed position by the block 10 which prevents the latch U 15 from pivoting.

20

Figures 9 and 10 illustrate the partially open position. The latch pin 16 has been pushed upwards thereby raising the latch

- Page 17 -

U 15 above the block 10 and so permitting same to pivot towards the open position as the gate panel 4 and hinge members 5,6 are moved away from the vertical cylinder 1.

5 Figure 11 illustrates the fully open position wherein the legs of the latch U 15 have pivoted to an acute angle to legs of the hinge U 13, and are clear of the vertical cylinder 1. It can be seen in this Figure 11 that when the gate panel 4 and hinge members 5,6 are moved towards the vertical cylinder 1 to
10 close the gate, the vertical cylinder 1 contacts the inside leg of the latch U 15, causing it to pivot towards the closed position, as can be seen by following back from the position of Figure 11 to that of Figure 9 and then of Figure 7. When the position of Figure 7 is reached, the latch U 15 falls to
15 the top of the hinge member 5,6 and is held in place by the block 10. In the present embodiment this fall is aided by a biasing force supplied by spring 17 acting in a downward direction against latch pin 16. The biasing force ensures that the latch U 15 goes down to rest on the hinge member 5,6
20 where it is locked by the block 10.

As illustrated in Figure 1, control bar 18 joins the latch

- Page 18 -

pins 16 on each end of the gate panel 4 so that when the control bar 18 is raised, both latch U's 15 on that end are moved up so they can pivot to the open position.

5 Figure 12 illustrates an alternate embodiment which could be used for a lighter duty application. The upper and lower hinge members 35, 36 and latch member 34 are the substantially the same as those illustrated in Figures 2 to 6, however only one latch member 34 is utilized and located approximately
10 midway between the upper and lower hinge members 35, 36. The block (not shown) to lock the latch member in the closed position, and the sleeve 31 to accommodate the pin 32 of the latch member 34 are located on a latch bracket 30 rather than on the hinge members.

15 This embodiment illustrates the principle of the gate which simply requires that some latch mechanism be provided to hold the hinge U's 13 into engagement with the vertical cylinders 1. This mechanism may be located and act at any point along
20 the vertical column so long as it exerts a force that holds the hinge members and vertical cylinder together.

- Page 19 -

Figures 13 and 14 illustrate another alternate embodiment. The hinge member 54 is identical to that illustrated in Figures 2,3 and 4, and acts to lock the latch U into the closed position in the same manner. The clamp leg 52 and push leg 53 of the latch U are, however, vertically separated, but it can be seen that the action of the latch member is the same. The push leg 53 is first contacted by the vertical post 51 as the gate is pushed closed and pivots to bring the clamp leg 52, which is rigidly attached to the push leg 53, into engagement with the vertical cylinder 51, at which point the latch member drops and the clamp leg 52 is locked behind the block 50. The latch pin 55 passes through sleeve 56 on the hinge member 54 and is supported near the lower push leg by lower sleeve 57. The latch pin 55 is biased by conventional means (not shown) and a control rod (not shown) moves the upper and lower latch members together.

Figure 15 illustrates a simple embodiment of the invention which does not provide the automatic latching feature wherein the hinge member 64 is held in engagement with a vertical cylinder 61 by a latch bar 62 which pivots on a pivot pin 65 one side of the hinge U 63. The latch bar 62 closes the open

- Page 20 -

end of the hinge U 63, latching it into a closed position. The latch bar 62 drops behind block 60, and is manually pivoted upwards to release the hinge U 63 and open the gate.

5 It can be seen that the hinge members, latch members, support members and controls could easily be packaged as a kit for installation on any closure means where two-way hinging was desirable. The assemblies as illustrated in Figure 1 would require only two bolt holes in each corner of the gate panel
10 to be installed, and any common cylindrical tubing would suffice for the ends of the opening. The support member could then be installed to the tubing.

The foregoing is considered as illustrative only of the
15 principles of the invention. Further, since numerous changes and modifications will readily occur to those skilled in the art, it is not desired to limit the invention to the exact construction and operation shown and described, and accordingly, all such suitable changes or modifications in
20 structure or operation which may be resorted to are intended to fall within the scope of the claimed invention.

AMENDED PAGE

21

CLAIMS:

I claim:

1. A gate for installation in an opening defined on each side by a vertical column, said vertical columns defining vertical cylinders at portions thereof, said vertical cylinders having inner sides facing each other across the width of the opening, and outer sides opposite said inner sides, said gate operable so as to open from either end thereof, said gate comprising:

a gate panel having two ends and two sides;

a fixed U-shaped top hinge member extending from an upper portion of each end of said gate panel and a fixed U-shaped bottom hinge member extending from a lower portion of each end of said gate panel such that open ends of said U-shaped hinge members are aligned towards one side of said gate panel and aligned with said vertical cylinders such that when said gate is closed each said U-shaped hinge member engages said

AMENDED PAGE

22

vertical cylinders such that a first leg thereof lies on said inner side of one of said vertical cylinders, substantially perpendicular to said opening and the second leg thereof lies on said outer side of one of said vertical cylinders, substantially perpendicular to said opening;

a support member extending radially from each said vertical cylinder such that a bottom edge of one said hinge member on each end of said gate is supported thereby when that end of said gate is closed;

a U-shaped latch member pivotally attached about a vertical axis to each end of said gate panel such that said latch members can pivot from a closed position engaging said vertical cylinders such that legs of said latch members are perpendicular to legs of said hinge members, thereby securing said hinge members to said vertical cylinders, to an open position wherein said legs of said latch members are at an acute angle to said legs of the hinge members, thereby releasing said hinge members to be moved away from said vertical cylinders;

AMENDED PAGE

23

controls to selectively lock said latch members into said closed position and to release said latch members, allowing said latch members to pivot into said open position.

2. The gate of Claim 1 wherein said control comprises biasing means to lock said latch member into said closed position when said legs of the latch member are pivoted into said closed position.
3. The gate of Claim 2 wherein said pivotal attachment of said latch members to said ends of the gate panel comprises a vertical pin fixed to the closed end of the U of each said latch member, said pin engaging a vertical aperture defined by a member fixed to said gate panel, said pin and latch member thereby free to rotate and to move vertically in said aperture.
4. The gate of Claim 3 wherein said controls comprise a block fixed to said gate panel such that when said

AMENDED PAGE

24

latch member is in the closed position, said latch member is held in a bottom vertical position by said biasing means wherein said block prevents pivoting of the latch member and further comprises means to raise said latch member against said biasing force to an upper vertical position wherein said latch member can pivot over the top of said block and rest on said block in the open position when said raising means is released.

5. The gate of Claim 1 further comprising a latch member vertically adjacent to each said hinge member.

6. The gate of Claim 4 further comprising a latch member vertically adjacent to each said hinge member and wherein said controls comprise a vertical lifting member joining the latch members on each end of said gate panel.

AMENDED PAGE

25

7. The gate of Claim 6 wherein said vertical apertures are defined by said hinge members and wherein said blocks are fixed to the top of said hinge members.
8. The gate of Claim 1 wherein the fixed position of the U of said hinge members relative to said gate panel can be adjusted closer to or farther from said gate panel.
9. The gate of Claim 7 wherein the fixed position of the U of said hinge members relative to said gate panel can be adjusted closer to or farther from said gate panel.
10. The gate of Claim 1 wherein said support members extend from the outer sides of said vertical cylinders.

AMENDED PAGE

26

11. The gate of Claim 9 wherein said support members extend from the outer sides of said vertical cylinders.

12. A kit for installation on a gate to make the gate operable so as to open from either end thereof, the gate comprising an opening defined on each side by a vertical column, said vertical columns defining vertical cylinders at portions thereof, said vertical cylinders having inner sides facing each other across the width of an opening, and outer sides opposite said inner sides, and a gate panel having two ends and two sides, said kit comprising:

a fixed U-shaped top hinge member adapted for attachment so as to extend from an upper portion of each end of said gate panel and a fixed U-shaped bottom hinge member adapted for attachment so as to extend from a lower portion of each end of said gate panel such that open ends of said U-shaped hinge members are aligned towards one side of said gate panel and aligned with said vertical cylinders such

AMENDED PAGE

27

that when said gate is closed each said U-shaped hinge member engages said vertical cylinders such that a first leg thereof lies on said inner side of one of said vertical cylinders, substantially perpendicular to said opening and the second leg thereof lies on said outer side of one of said vertical cylinders, substantially perpendicular to said opening;

a support member adapted for attachment so as to extend radially from each said vertical cylinder such that a bottom edge of one said hinge member on each end of said gate is supported thereby when that end of said gate is closed;

a U-shaped latch member adapted for pivotal attachment about a vertical axis to each end of said gate panel such that said latch members can pivot from a closed position engaging said vertical cylinders such that legs of said latch members are perpendicular to legs of said hinge members, thereby securing said hinge members to said vertical cylinders, to an open position wherein said legs of said latch members are at an acute angle to said legs of the hinge members,

AMENDED PAGE

28

thereby releasing said hinge members to be moved away from said vertical cylinders;

controls to selectively lock said latch members into said closed position and to release said latch members, allowing said latch members to pivot into said open position.

13. A gate for installation in an opening defined on each side by a vertical column, said vertical columns defining vertical cylinders at portions thereof, said vertical cylinders having inner sides facing each other across the width of the opening, and outer sides opposite said inner sides, said gate operable so as to open from either end thereof, said gate comprising:

a gate panel having two ends and two sides;

a fixed U-shaped top hinge member extending from an upper portion of each end of said gate panel and a fixed U-shaped bottom hinge member extending from a lower portion of each end of said gate panel such that open ends of said U-shaped hinge members are aligned

AMENDED PAGE

29

towards one side of said gate panel and aligned with said vertical cylinders such that when said gate is closed each said U-shaped hinge member engages said vertical cylinders such that a first leg thereof lies on said inner side of one of said vertical cylinders, substantially perpendicular to said opening and a second leg thereof lies on said outer side of one of said vertical cylinders, substantially perpendicular to said opening;

a support member extending radially from each said vertical cylinder such that a bottom edge of one said hinge member on each end of said gate is supported thereby when that end of said gate is closed;

a latch operable to lock said U-shaped hinge members into engagement with said vertical cylinders when said gate is closed.

14. The gate of Claim 13 wherein said latch comprises a U-shaped latch member pivotally attached about a vertical axis to each end of said gate panel such that said latch members can pivot from a closed position

AMENDED PAGE

30

engaging said vertical cylinders such that legs of said latch members are perpendicular to legs of said hinge members, thereby securing said hinge members to said vertical cylinders, to an open position wherein said legs of said latch members are at an acute angle to said legs of the hinge members, thereby releasing said hinge members to be moved away from said vertical cylinders.

15. The gate of Claim 13 wherein said latch comprises a U-shaped latch member wherein legs of said U are separated by a vertical distance, said latch member pivotally attached about a vertical axis to each end of said gate panel such that said latch members can pivot from a closed position engaging said vertical cylinders such that the legs of said U are perpendicular to legs of said hinge members, thereby securing said hinge members to said vertical cylinders, to an open position wherein said legs of said latch members can pivot, allowing said hinge members to be moved away from said vertical cylinders;

AMENDED PAGE

31

16. The gate of Claim 13 wherein said latch comprises a bar operable to close an open end of the U of said hinge member when said hinge member is engaged in said vertical column.

17. The gate of Claim 13 wherein said latch is operable to automatically latch the gate closed when the gate is pushed so that said hinge members become engaged in said vertical columns.

FIG. 1

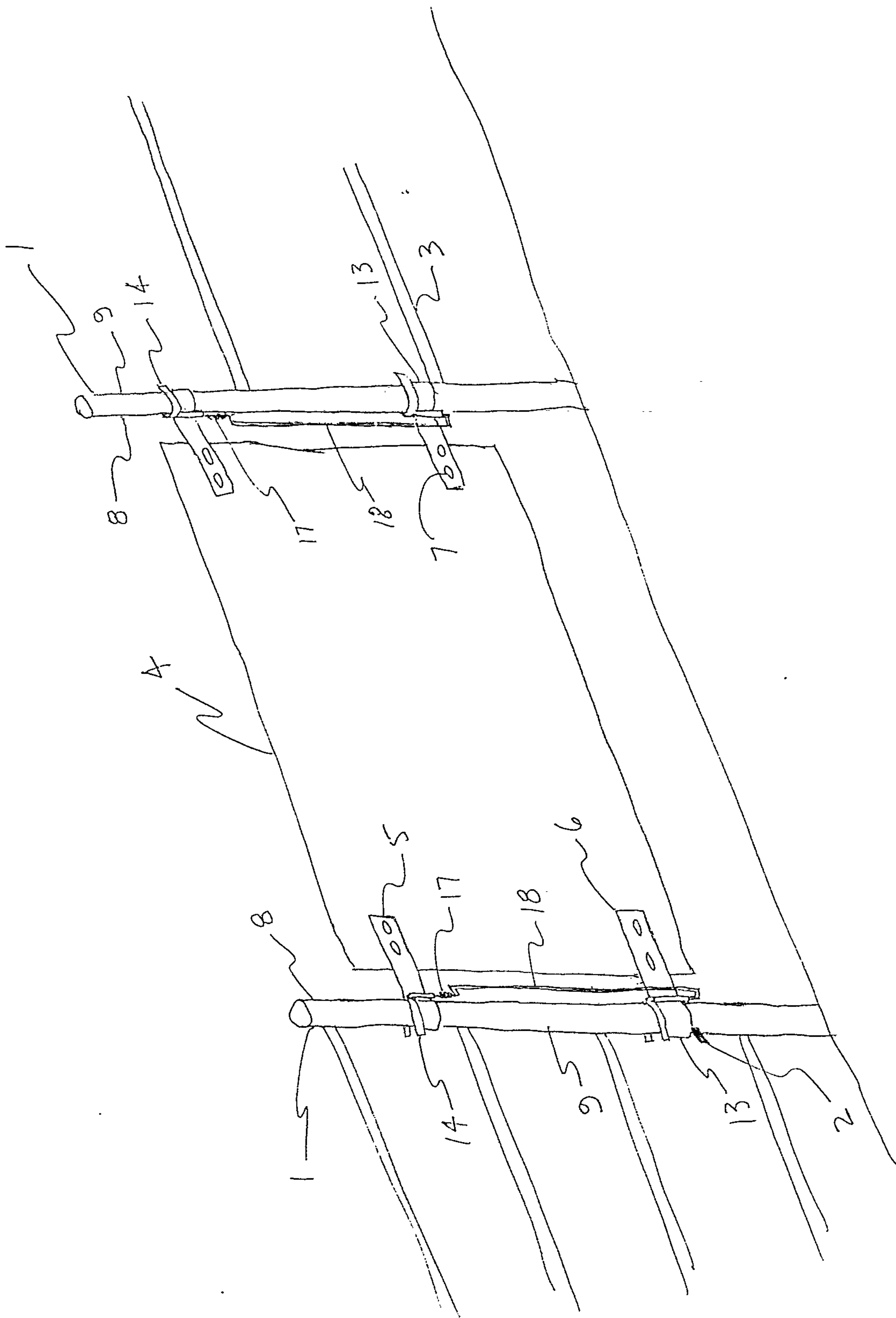

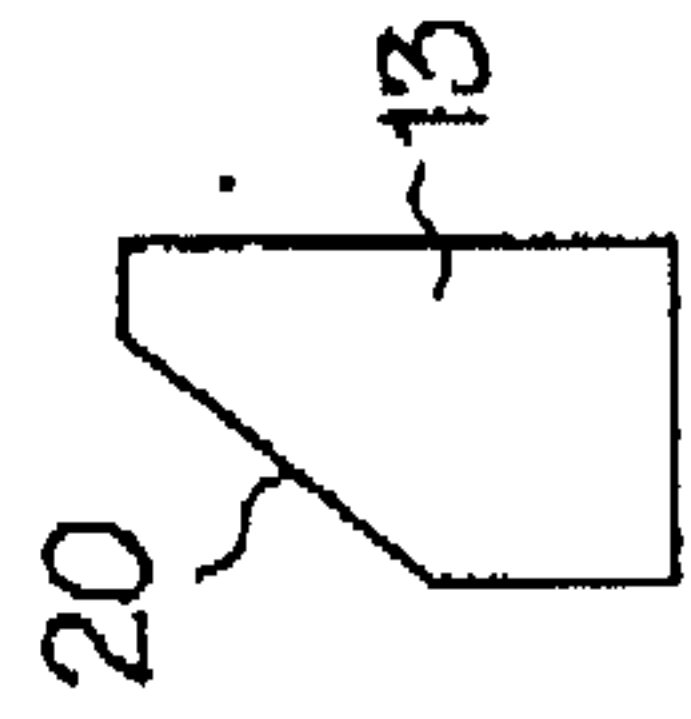

FIG. 2

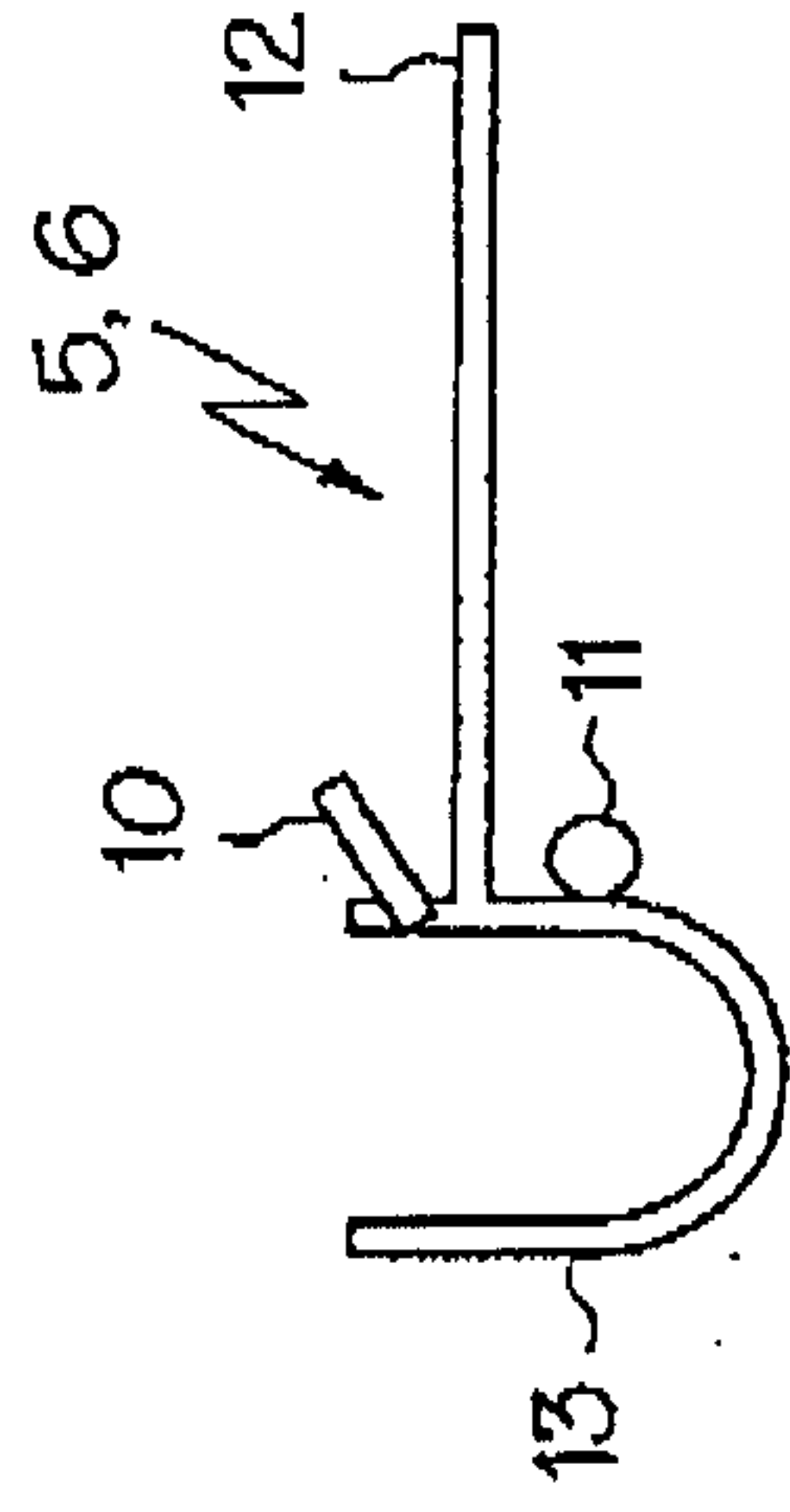

FIG. 3

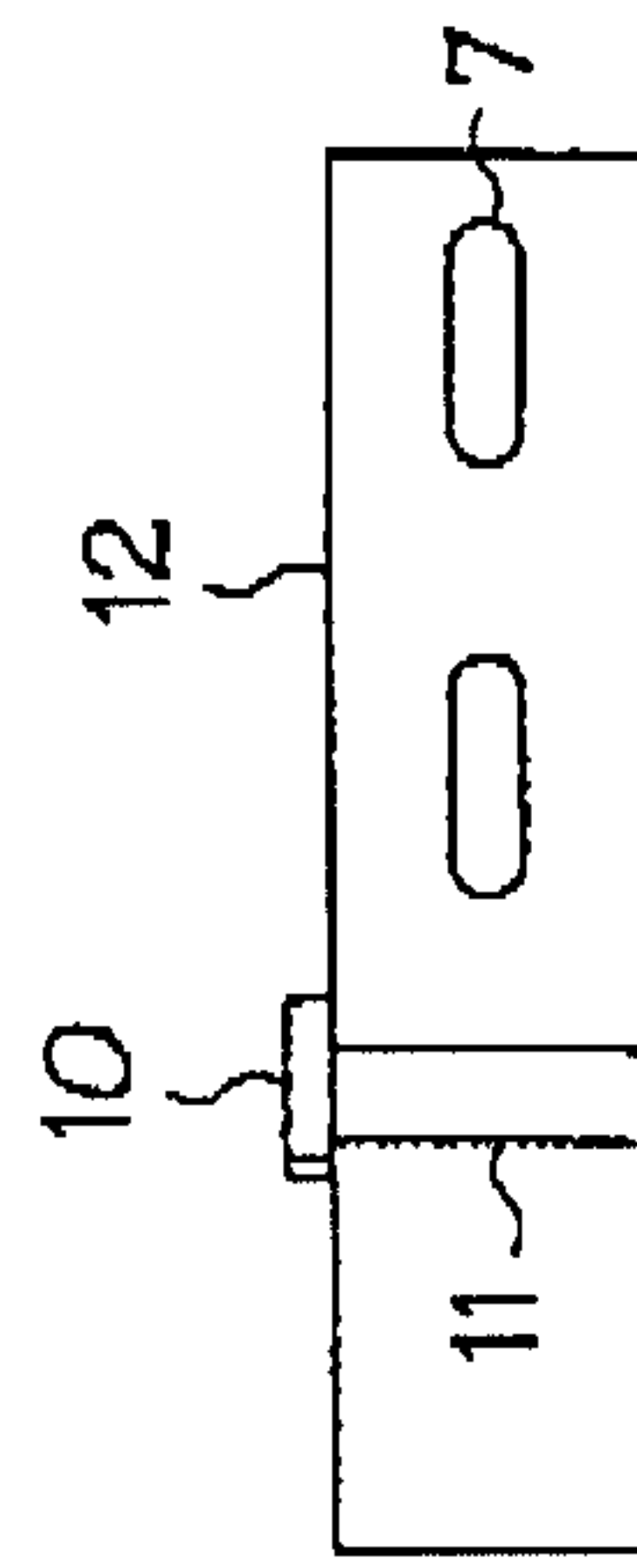

FIG. 4

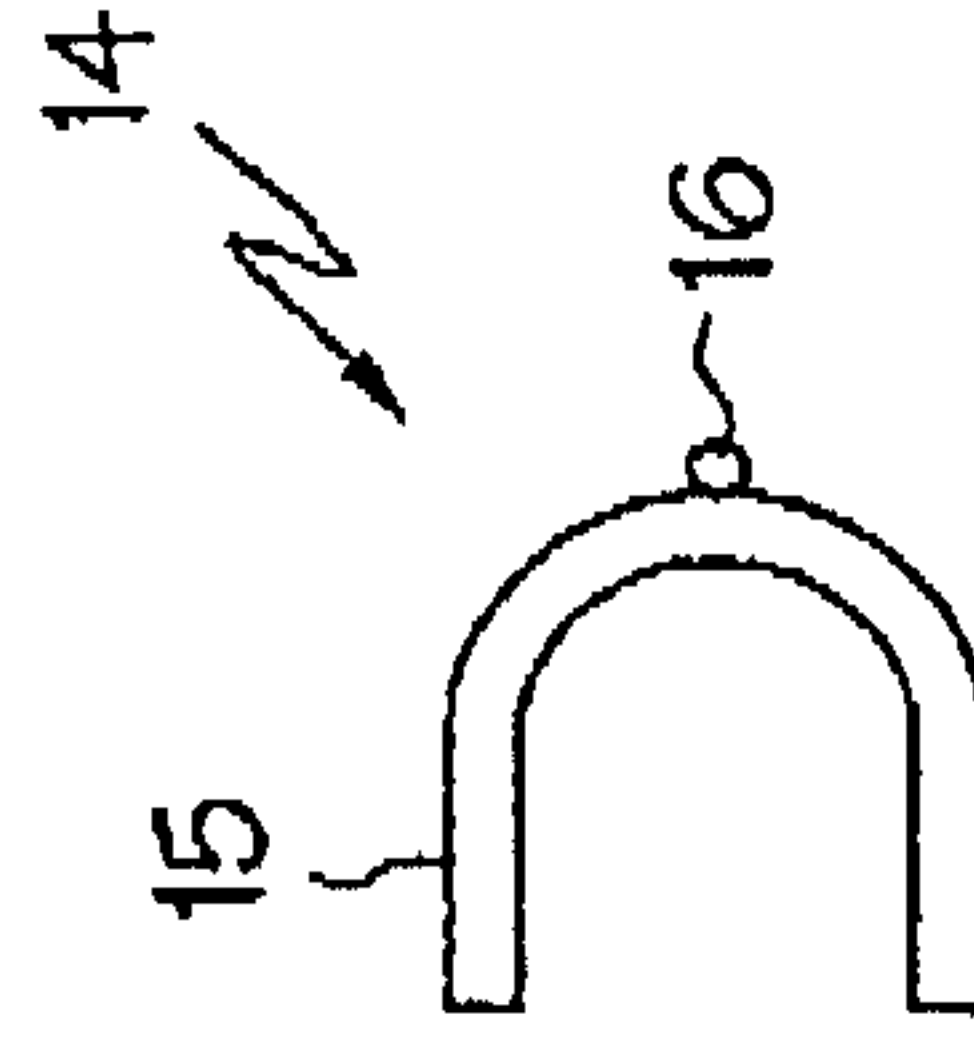

FIG. 5

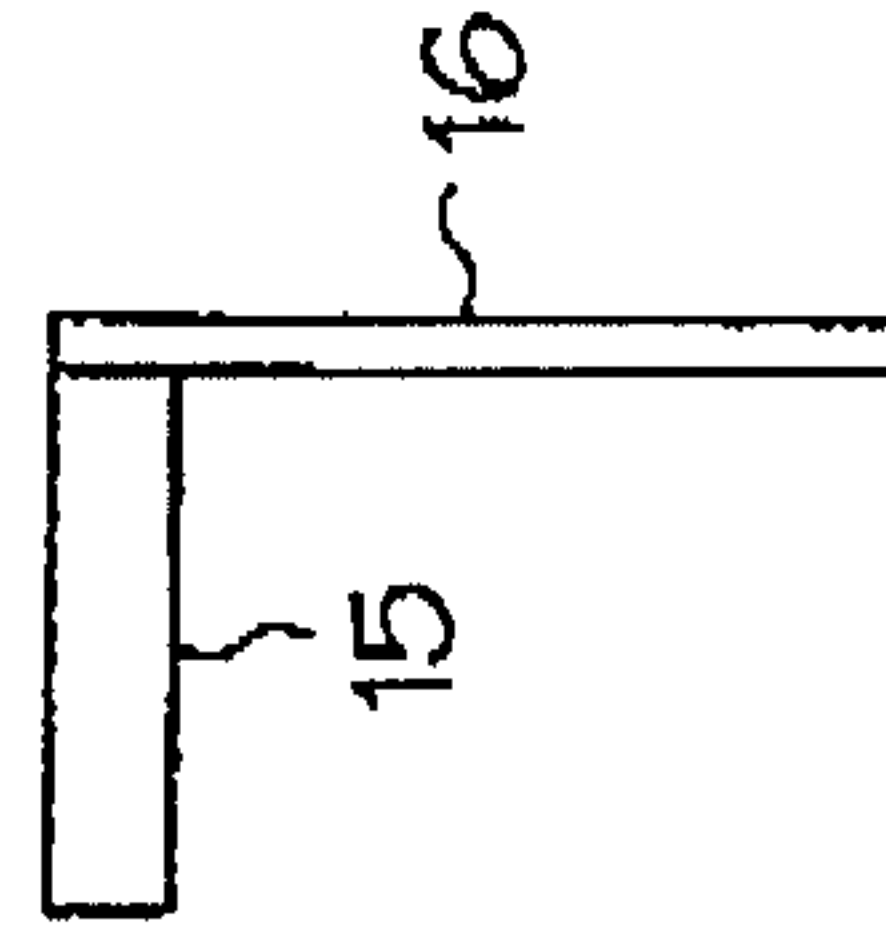
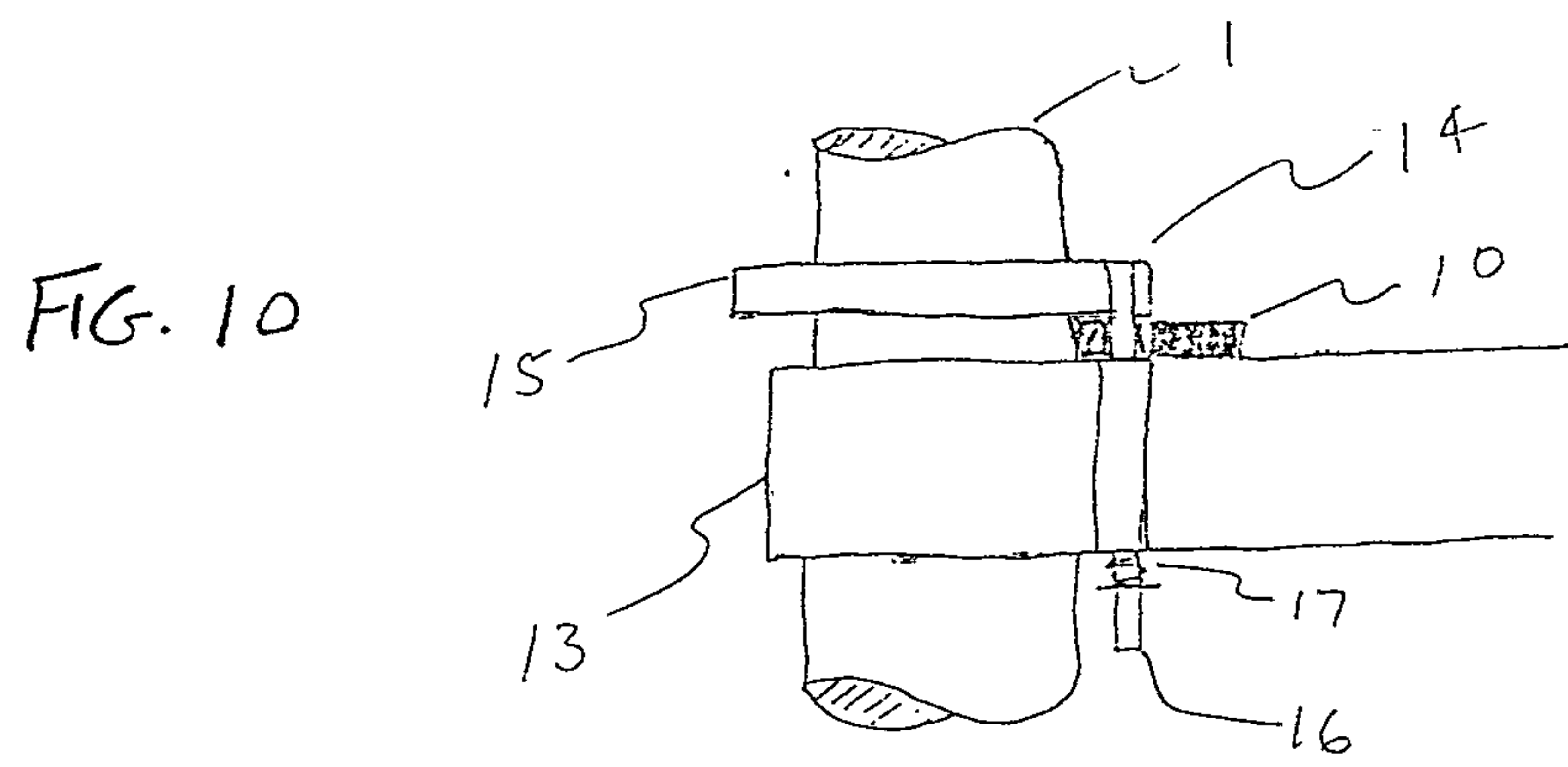
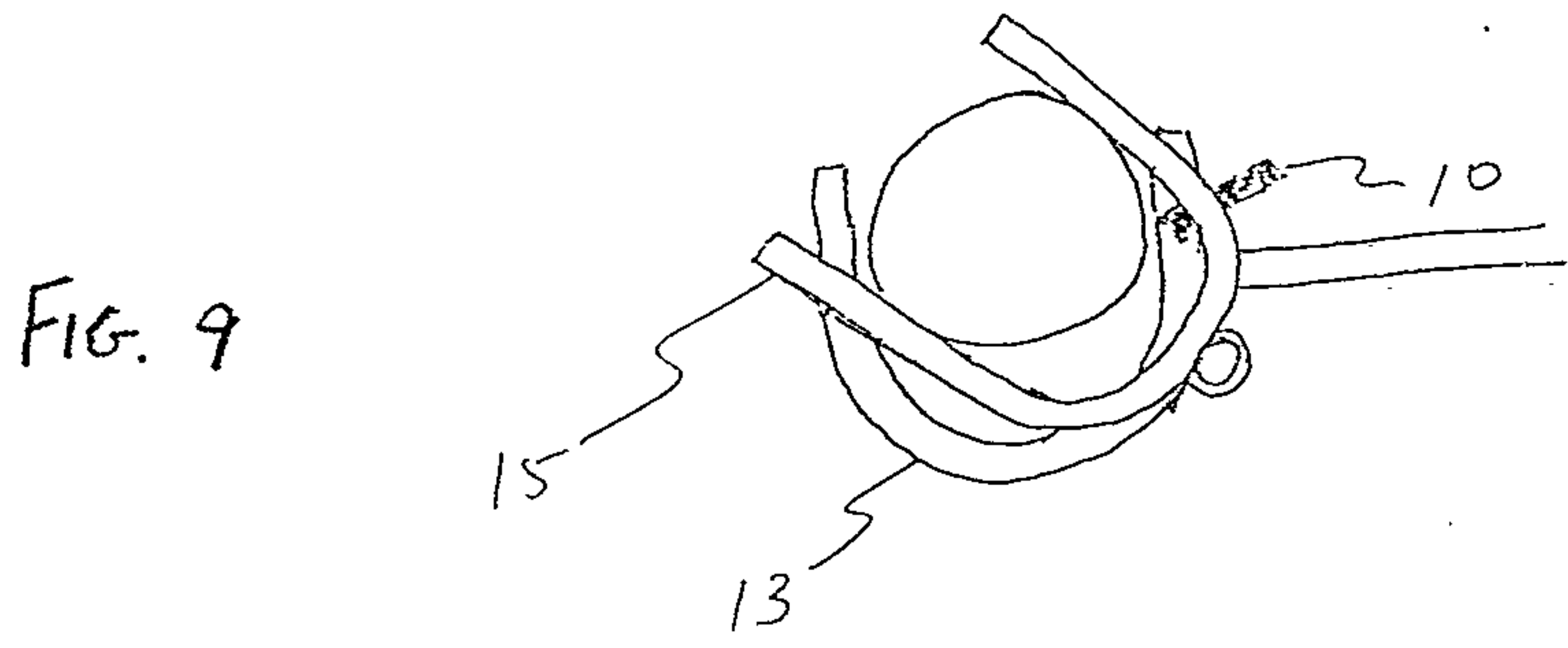
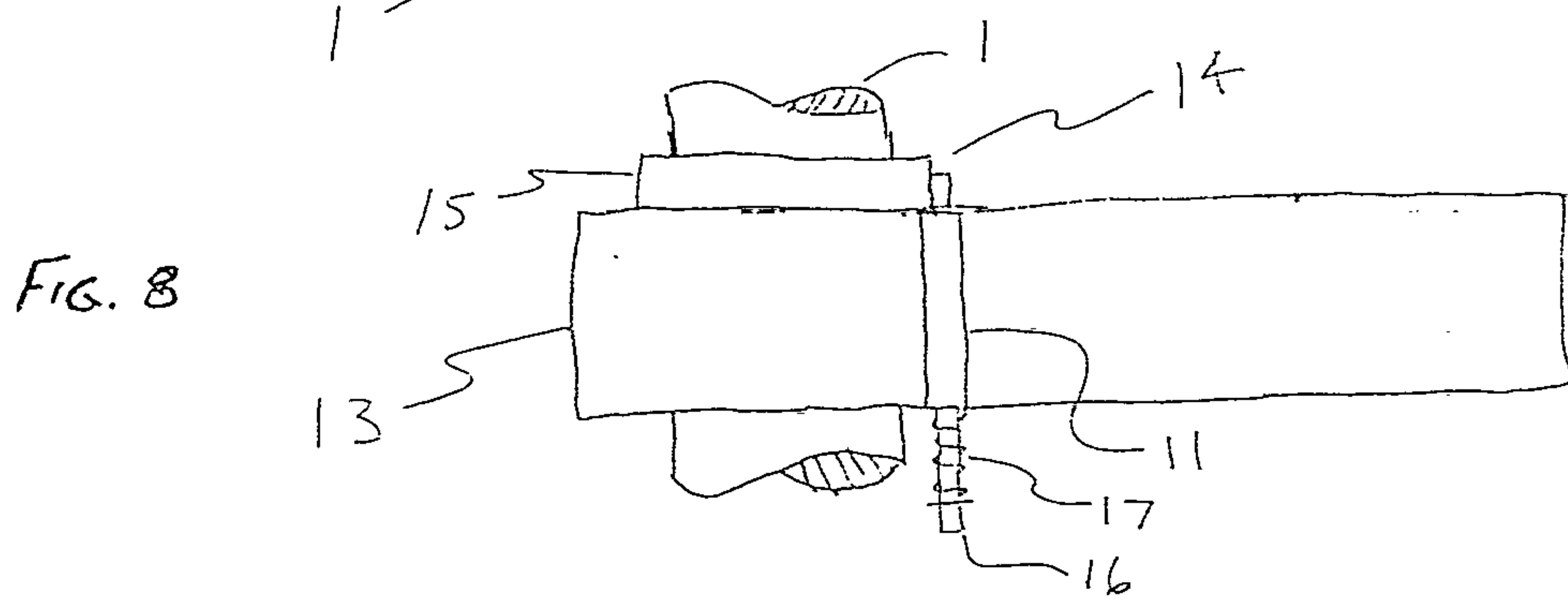
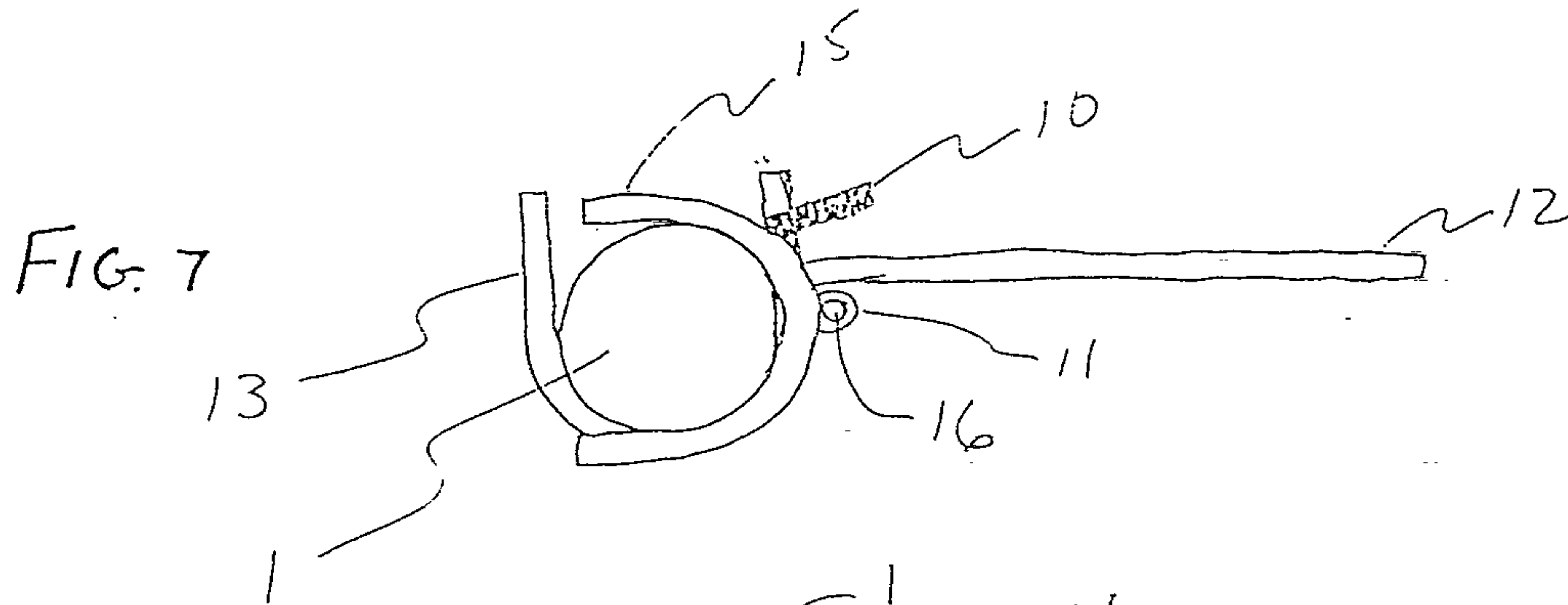

FIG. 6



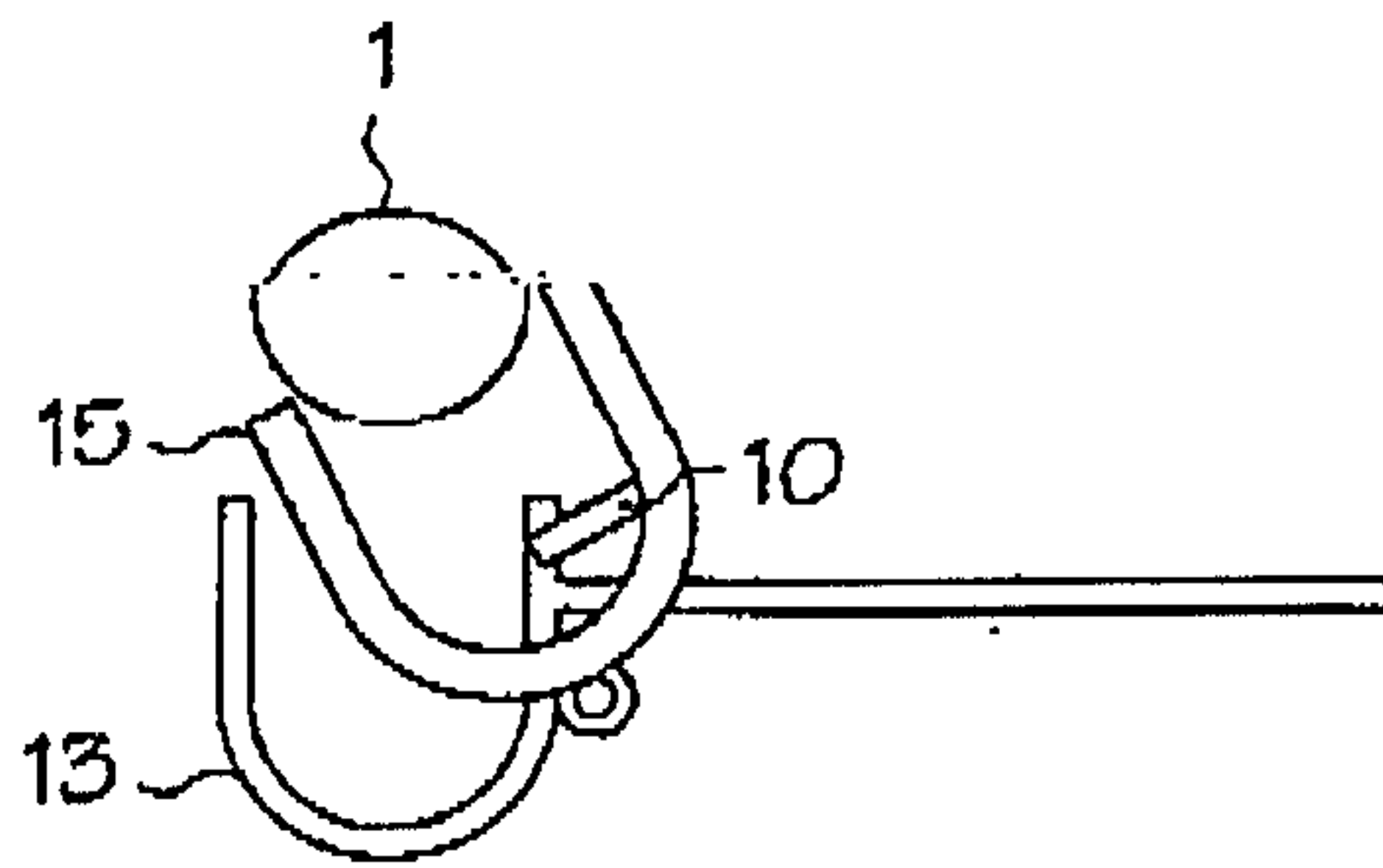

FIG. 11

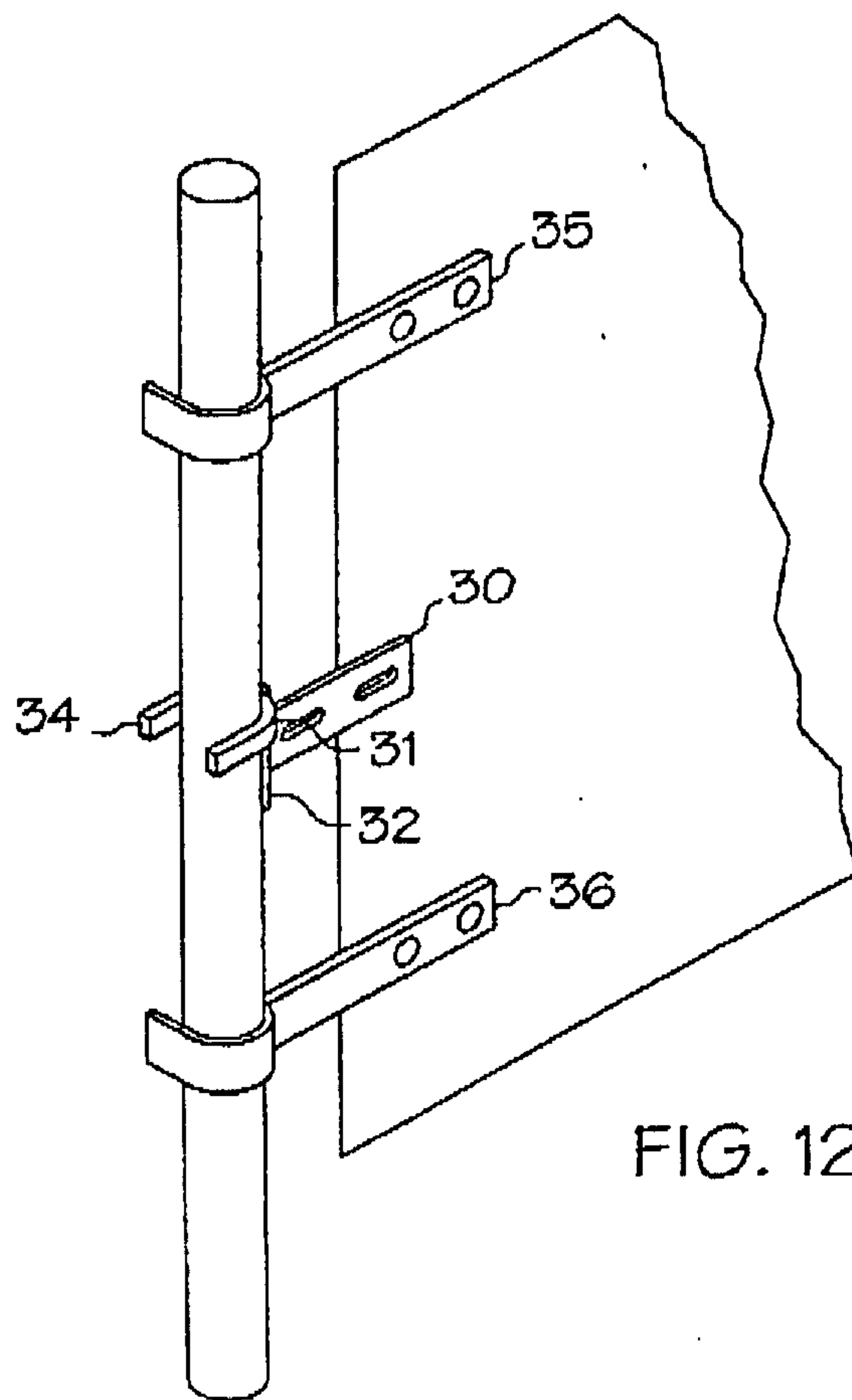

FIG. 12

FIG 13:

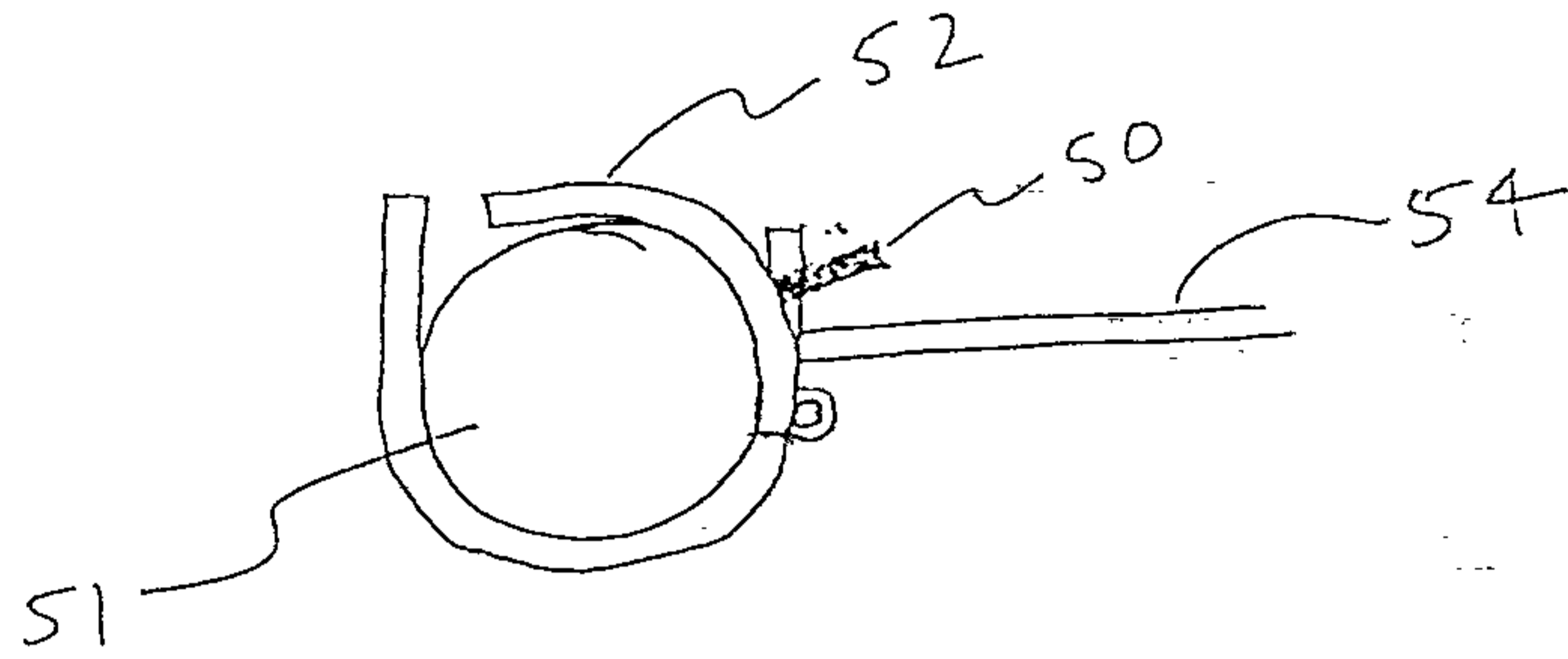

FIG 14:

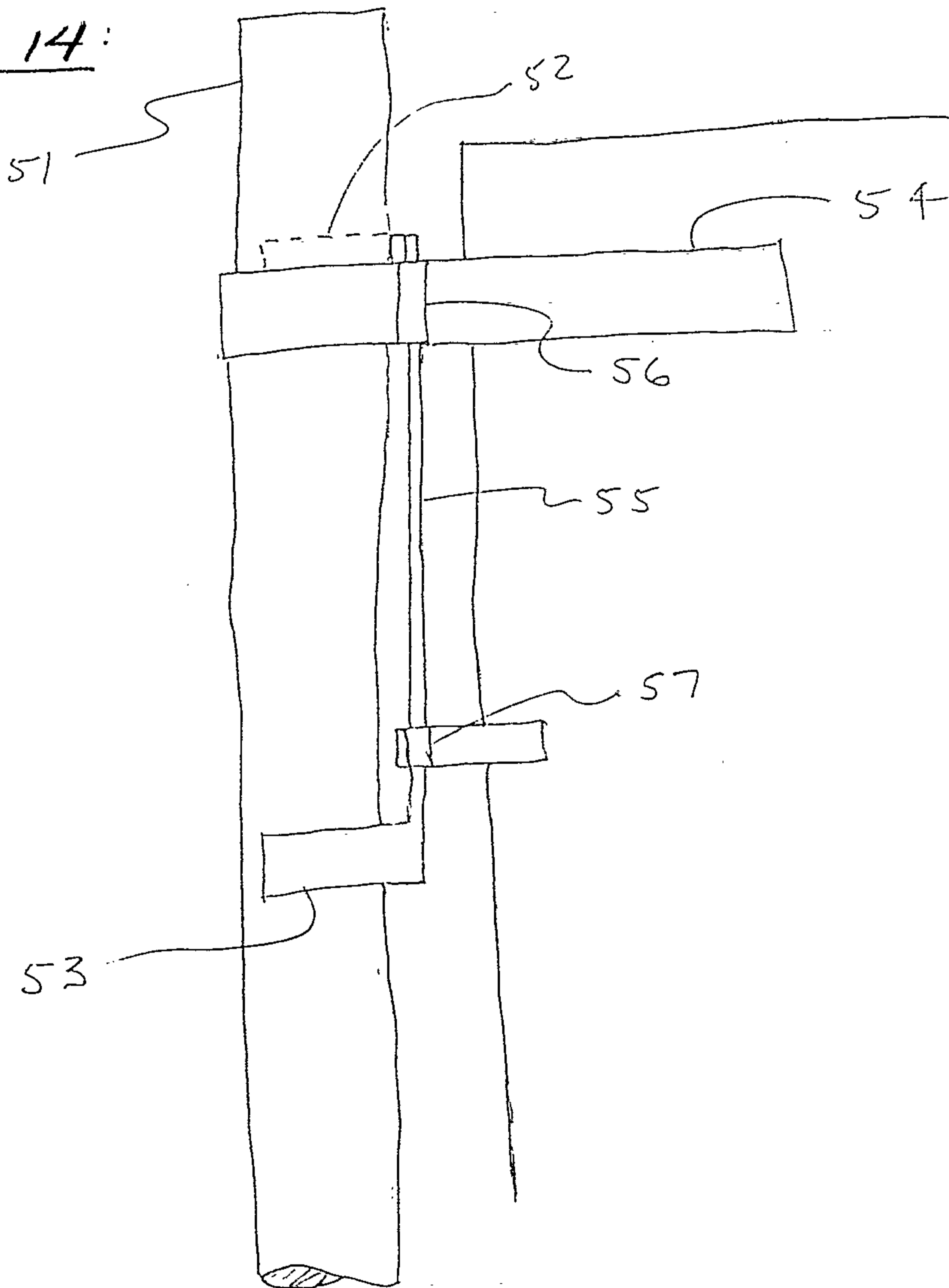

FIG. 15

