

(19) World Intellectual Property
Organization
International Bureau



(43) International Publication Date
22 July 2004 (22.07.2004)

PCT

(10) International Publication Number
WO 2004/060102 A2

- (51) International Patent Classification⁷: **A45D**
- (21) International Application Number: PCT/US2003/033824
- (22) International Filing Date: 23 October 2003 (23.10.2003)
- (25) Filing Language: English
- (26) Publication Language: English
- (30) Priority Data: 10/320,335 16 December 2002 (16.12.2002) US
- (71) Applicant (for all designated States except US): **AVON PRODUCTS, INC.** [US/US]; 1251 Avenue of Americas, New York, NY 10020-1196 (US).
- (72) Inventor; and
- (75) Inventor/Applicant (for US only): **KUREK, John** [US/US]; 287 Reservoir Road, Goshen, NY 10924 (US).
- (74) Agent: **RUGGIERO, Charles, N., J.**; Ohlandt, Greeley, Ruggiero & Perle, LLP, One Landmark Square, 10th Floor, Stamford, CT 06901-2682 (US).
- (81) Designated States (national): AE, AG, AL, AM, AT, AU, AZ, BA, BB, BG, BR, BY, BZ, CA, CH, CN, CR, CU, CZ, DE, DK, DM, DZ, EE, ES, FI, GB, GD, GE, GH, GM, HR, HU, ID, IL, IN, IS, JP, KE, KG, KP, KR, KZ, LC, LK, LR, LS, LT, LU, LV, MA, MD, MG, MK, MN, MW, MX, MZ, NO, NZ, PL, PT, RO, RU, SD, SE, SG, SK, SL, TJ, TM, TR, TT, TZ, UA, UG, US, UZ, VN, YU, ZA, ZW.
- (84) Designated States (regional): ARIPO patent (GH, GM, KE, LS, MW, MZ, SD, SL, SZ, TZ, UG, ZM, ZW), Eurasian patent (AM, AZ, BY, KG, KZ, MD, RU, TJ, TM), European patent (AT, BE, BG, CH, CY, CZ, DE, DK, EE, ES, FI, FR, GB, GR, HU, IE, IT, LU, MC, NL, PT, RO, SE, SI, SK, TR), OAPI patent (BF, BJ, CF, CG, CI, CM, GA, GN, GQ, GW, ML, MR, NE, SN, TD, TG).

[Continued on next page]

(54) Title: APPLICATOR BRUSH WITH EMPROVED BRISTLES

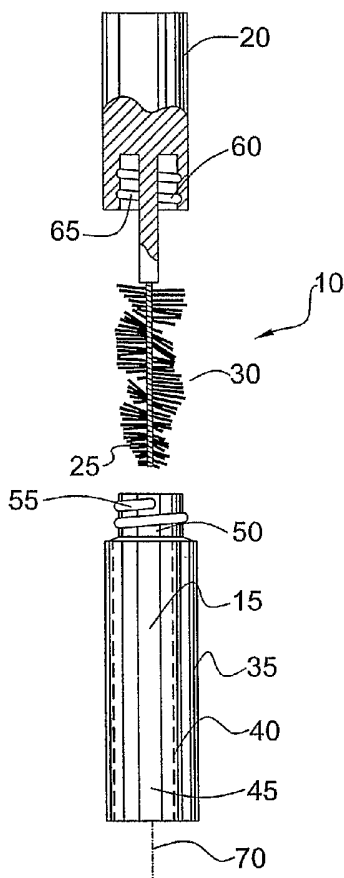

(57) Abstract: An applicator brush, preferably a mascara applicator brush, having enhanced bristle fibers is provided. The applicator brush has a brush core, and a number of bristle fibers preferably extending radially from the brush core. The bristles are made of two or more materials that are preferably coextruded together. The bristle fibers achieve performance characteristics such as antibacterial qualities, enhanced bristle surface structure, combing and loading characteristics. In this manner, enhanced application characteristics are achieved for the benefit of the user.

WO 2004/060102 A2



Published:

— *without international search report and to be republished upon receipt of that report*

For two-letter codes and other abbreviations, refer to the "Guidance Notes on Codes and Abbreviations" appearing at the beginning of each regular issue of the PCT Gazette.

APPLICATOR BRUSH WITH IMPROVED BRISTLES

BACKGROUND OF THE INVENTION

5 1. Field of the Invention

The present invention relates to a cosmetic applicator. More particularly, the present invention relates to a mascara brush with improved bristle
10 fibers.

2. Description of the Related Art

Applicator brushes, including mascara brushes, are
15 known in the art. Generally, a mascara applicator brush is inserted into a container having a reservoir of mascara or cosmetic medium. The bristle fibers pick up the mascara or cosmetic medium and carry it from the container for application onto the user's eyelashes.
20 Such applicators are shown in, for example, U.S. Patent No. 4,365,642 to Costa, U.S. Patent No. 4,733,425 to Hartel, et al., and U.S. Patent No. 4,887,622 to Gueret.

25 Typically, prior art mascara brushes tend to focus improvements on increasing the loading capacity of the brush. Loading is a term of art that refers to the mascara carrying capacity of the brush or bristle fibers. Basically, loading is the characteristic of
30 the amount of cosmetic medium left on the brush when removed from the reservoir. Generally, the prior art focuses upon an optimal amount of product load such that a finished appearance may be expeditiously accomplished in as few strokes as possible. Typically,

the prior art focuses upon the bristle head and the bristle fibers by varying the lengths and physical geometry of the bristle fibers to achieve improved loading of the brush.

5

Given the irregularity of application surfaces and thickness variations of the eyelashes, the user may not only desire to increase the load characteristics of the bristle fibers, but also to apply cosmetic medium in a comfortable manner. Since the skin is tender on the face and mascara application is performed near the eyes, rough bristle fibers and abrasive materials are disfavored. The prior art has attempted to solve some of these problems by increasing the flexibility attributes of the brush core. However, increased flexibility of the brush core is insufficient.

10
15

By utilizing improved bristle fibers, rather than conventional fibers or bristles, improved softness, surface characteristics and flexibility can be achieved, while maintaining the necessary structural stiffness to allow the user to better control the bristle fibers and improve combing and loading characteristics of the bristle fibers.

20
25

Thus, it is desirable to provide a mascara brush having bristle fibers that enable the user to more precisely and productively apply cosmetic product to the eyelashes and achieve a more skillful, comfortable, safe and productive cosmetic application with less loading.

30

SUMMARY OF THE INVENTION

It is an object of the present invention to provide an applicator brush, especially a mascara applicator brush, having co-extruded bristle fibers.

It is another object of the present invention to provide an applicator brush, especially a mascara applicator brush, having co-extruded bristle fibers made of nylon, polyester or elastomer.

It is yet another object of the present invention to provide an applicator brush, especially a mascara applicator brush, in which the bristle fibers have a core and a sheath thereabout, and the core and sheath are made of the same or different materials.

It is still another object of the present invention to provide an applicator brush, especially a mascara applicator brush, in which the bristle fibers have a structured shape, including but not limited to, protuberances or cavities, or indentations.

It is a further object of the present invention to provide an applicator brush, especially a mascara applicator brush, in which the bristle fibers are made of an elastomer or have an elastomeric longitudinal band.

It is yet a further object of the present invention to provide an applicator brush, especially a mascara applicator brush, in which the bristle fibers are filaments surrounded by a sheath of yarn.

It is still a further object of the present invention to provide an applicator brush, especially a mascara applicator brush, having bristle fibers that have additives thereon or incorporated therein.

5

These and other objects and advantages of the present invention are achieved by improved bristle constructions and shapes for an applicator brush of the present invention. The applicator brush has a brush
10 core and a number of bristles or bristle fibers extending, preferably radially, from the brush core. Preferably, the bristle fibers are co-extruded with protruberances or indentations, preferably random indentations, for surface structure. Preferably, the
15 bristle fibers have an additive such as an antibacterial agent. Also preferably, the bristle fibers are made of a thermoplastic or thermoelastic material.

20 The bristle fibers achieve improved performance characteristics such as improved antibacterial qualities, improved fiber surface structure, improved combing and improved loading characteristics over applicator brushes known in the art. In this manner,
25 better application characteristics are achieved for the benefit of the user.

DESCRIPTION OF THE DRAWINGS

30 The above and other objects, advantages and benefits of the present invention will be understood by reference to the detailed description provided below and the accompanying drawings.

Fig. 1 is a partially cross-sectional side view of an improved mascara brush of the present invention.

5 Figs. 2 to 8 are perspective views of various bristle fibers for use in a preferred embodiment of the improved mascara brush of Fig. 1.

Fig. 9 is a side view of a mascara brush of the present invention.

10

Fig. 10 is an exploded view of a bristle fiber end as shown in Fig. 9.

15 Figs. 11 to 14 are perspective views of yet further bristle fibers for use in a preferred embodiment of the improved mascara brush of Fig. 1.

DETAILED DESCRIPTION OF THE INVENTION

20 Referring to the drawings and in particular Fig. 1, there is provided an applicator brush generally represented by reference numeral 10. The applicator brush, preferably a mascara applicator brush, 10 can be removably secured, or made an integral part of, a cap
25 20. Cap 20 is removably securable to a container 15 so that brush 10 is positioned in the container. The brush 10 has a brush core 25 and one or more types of bristles or bristle fibers 30 extending from the brush core.

30

The container 15 may have any elongated shape in order to accommodate brush 10. The cap 20 has a lower end 60 that receives brush core 25. The container 15 has a cylindrical outer wall 35 and cylindrical inner

wall 40 defining a product storage chamber 45 that can receive bristle fibers 30 of mascara brush 10. An exemplary aspect of product storage chamber 45 is that the chamber has a volume that holds a suitable amount of mascara or cosmetic medium therein for repeated application of mascara. The container 15 and cap 20 may be made of a thermoplastic material or any other solid material.

10 The container 15 preferably includes an upper end 50 having a number of male threaded members 55. The cap 20 has a lower end 60, and preferably also has a number of female threaded members 65 that removably engage male threaded members 55 when the male threaded member mate with the female threaded members. In this manner, bristle fibers 30 are positioned into liquid cosmetic medium disposed in chamber 45 when cap 20 is secured to container 15.

20 As an example, brush core 25 may have a cylindrical configuration of bristle fibers 30 suitably flexible for the user to apply cosmetic medium to the user's eyelashes. An exemplary aspect of brush core 25 is that the brush core may be twisted about a longitudinal axis 70 to displace bristle fibers 30 trapped therebetween, and thereby distribute cosmetic medium to user's eyelashes. The brush core 25 preferably has a diameter that is about 0.0157 inches to about 0.0355 inches. The bristle fibers 30 radially extend from brush core 25.

The bristle fibers 30 may be formed by one or more of the filaments sold under the trade name Pedex & Co. GmbH from Pedex High Tech Filaments. These filaments

are covered by U.S. Patent No. 6,163,918, U.S. Patent No. 6,048,478 to Weihrauch, and U.S. Patent No. 5,540,873 to Knapp.

5 The bristle fibers 30 may have a diameter about 0.002 to about 0.015 inches, preferably about 0.005 inches to about 0.008 inches. The bristle fibers 30 may be formed so that some or all of the fibers have a varying diameter or a varied length. The bristle
10 fibers 30 may be radially fastened to brush core 25 in any manner known in the art including staple set, fuse, adhesive or molding methods.

 In a preferred embodiment of the present
15 invention, bristle fibers 30 may be formed from a polymer including a polyester or nylon; an elastomer; or any combinations thereof.

 In a more preferred embodiment of the present
20 invention, at least some of bristle fibers 30 are made of two or more materials, which are preferably coextruded together, as a single fiber. As shown in Fig. 2, bristle fibers 30 may be formed, for example, with a core 130 surrounded by a sheath 140. The core
25 130 and sheath 140 may alternatively be made of nylon, such as nylon 6.6, 6.12; a polyester including, but not limited to, a polyethylene terephthalate or polybutylene terephthalate; or an elastomer, including, but not limited to, a thermoelastic or a thermoplastic.
30 A preferred thermoplastic is polypropylene. In a preferred embodiment, bristle fibers 30 are formed with core 130 made of nylon or polyester and sheath 140 made of thermoplastic elastomer. In yet another preferred embodiment, bristle fibers 30 are formed with core 130

made of a thermoplastic elastomer and sheath 140 made of nylon or polyester. The bristle fibers 30 are formed such that core 130 extends such that it is revealed as a tip at an end of bristle fiber 30
5 opposite brush core 25. In this manner, improved application of mascara or cosmetic medium to the eyelashes is achieved without abrasive qualities of prior art bristles.

10 In this embodiment, each bristle fiber 30 may have any one of the following cross-sectional shapes: rectangular, a cylinder, a square, a spiral, a toroidal, a triangle, a polyhedron, or any combinations thereof.

15 Another coextruded fiber of the present invention is shown in Fig. 3. In this embodiment, bristle fiber 30 is formed as a two or more component filament having a core partially surrounded by a sheath. The sheath is
20 denoted as bristle fiber portion 145 and the partially surrounded core as longitudinal band 150. The bristle fiber 30 may have a cylindrical cross-sectional shape configuration as shown in Fig. 3, a rectangular cross-sectional shape configuration as shown in Fig. 4, or
25 any other bristle fiber shape configurations, such as square, a spiral, a toroidal, a triangle, a polyhedron, or any combinations thereof.

The longitudinal band 150 extends along the
30 longitudinal axis of bristle fiber 30. The band 150 may be placed at the ends of bristle fiber 30, in the center thereof, or at desired portions along the longitudinal axis thereof. The band 150 may have a

lateral extent, be square shaped, or rectangularly shaped.

The bristle fiber portion 145 may be made from
5 nylon, polyester or any elastomer. Preferably, bristle
fiber portion 145 is nylon or polyester. The band 150
may be made of an elastomer, nylon or polyester. The
band 150 is preferably made of a material that is
10 different from the material for the bristle fiber
portion 145. In this preferred embodiment, bristle
fibers 30 have a suitable amount of flexibility and
rigidity for an improved application of cosmetic medium
to the user's eyelashes.

15 In another preferred embodiment of the present
invention shown in Fig. 5, bristle fiber 30 has a core
130 surrounded by a sheath 180 of textile yarn. The
yarn extends along at least a portion of bristle fiber
30. The yarn covers preferably the entire surface of
20 bristle fiber 30. The core 130 can be made of nylon,
polyester, a thermoelastic or a thermoplastic
elastomer. The yarn sheath 180 of bristle fibers 30 is
softer and improves application of the cosmetic medium
to the eyelashes to ensure less abrasion between the
25 bristle fibers and the user's eyelashes and surrounding
skin tissues.

In other preferred embodiments of the present
invention, bristle fibers 30 may be structured fibers.
30 Such structured fibers are shown in Figs. 6 to 10.
These structured fibers have some physical attributes
that enhance one or more attributes such as improved
load characteristics or comfort.

As shown in Fig. 6, each bristle fiber 30 may have a number of cavities or apertures 120 disposed on an otherwise smooth or planar surface of the bristle fiber. As shown in the embodiment of Fig. 7, bristle fiber 30 may have a number of indentations 160 disposed around such a surface of the bristle fiber. Still further, an applicator brush 10 may have bristle fibers 30 that have any combinations of cavities or apertures, and indentations. The number of cavities or apertures, and indentations may serve to store and release one or more germicidal powders, mascaras, cosmetic mediums, dyes, hair care products, hair growth stimulating products, combing gel products, lubricants or any other suitable materials, and further increase the loading characteristics of the particular materials.

The structured fiber as shown in Fig. 7 may be formed of a polymer, namely a nylon or polyester, or a thermoplastic elastomer, such as polypropylene. In another structured fiber as shown in Fig. 8, one or more protuberances 151 are disposed along an otherwise smooth or planar surface of bristle fiber 30. The bristle fiber 30 and/or the protuberances 151 may be made from, for example, an elastomer, a nylon, a polyester, or any combinations thereof.

In yet another structured fiber as shown in Figs. 9 and 10, bristle fiber 30 may be modified by mechanical action to form split ends/multiple fibers 31. One method of forming such multiple fibers is described in U.S. Patent No. 5,020,551, which is incorporated herein by reference in its entirety. The multiple fibers 31 serve to volumize the surface area

of a brush and maximize the amount of material to be applied by the user.

In another preferred embodiment of the present invention, bristle fibers 30 may be improved shape fibers as shown in Figs. 11 to 13. These shaped fibers have a geometry that enhances scrubbing characteristics, improves loading characteristics or enhances the comfort of the bristle fibers 30. An exemplary aspect of the shaped fiber is that of a rectangular or substantially square cross-section as shown in Fig. 11.

In yet another preferred embodiment shown in Fig. 12, bristle fiber 30 can have an uneven surface. This uneven surface may be the result of a rough or bumpy design, so as to form one or more lateral bands 190.

The bristle fibers 30 may also include pyramid shaped edges, as shown in Fig. 13. The bristle fibers 30 may be shaped with lateral sides having a solid figure with a polygonal base and triangular faces that meet at a common point. Also, bristle fibers 30 may also have tubular shaped ends or edges that are substantially shaped as a polyhedron. The pyramid shaped edges may increase the scrubbing characteristics of bristle fibers 30.

In another preferred embodiment shown in Fig. 14, bristle fibers 30 may have an additive in or on the bristle fibers, such as an antibacterial agent or a fragrance. The antibacterial agent may be triclosan or any other antibacterial material suitable for improving the germicidal properties of bristle fibers 30.

In another preferred embodiment of the present invention, mascara brush 10 may have a combination of all of the above-mentioned filaments disposed as
5 bristle fibers 30. For example, any one of the structured fibers, shaped fibers or additive fibers may be formed of the nylon, polyester, or elastomer materials used in the coextruded fibers. Accordingly, a final fiber coextruded in a core/sheath arrangement
10 could also be, for example, rectangular in cross-section, with protruberances on its surface and impregnated with an antimicrobial additive.

The bristle fibers 30 of the present invention
15 enable the user to easily achieve a sanitary fiber, with increased flexibility, comfort and loading characteristics. The exemplary bristle fibers 30 thereby achieve increased and improved performance characteristics and control of the combing of brush 10
20 and loading of cosmetic medium to achieve a more efficient and productive application of cosmetics to the user's eyelashes.

The mascara applicators of the present invention
25 may also include preferred fibers having different lengths and/or different zones as disclosed in U.S. Patent No. 5,853,011, which is incorporated herein by reference in its entirety.

30 Although the present invention has been described in light of the most preferred embodiment, a mascara applicator, the fibers described may provide other types of cosmetic, dermatological or pharmaceutical applicators. For example, applicator brushes within

the scope of the present invention, include but are not limited to, liquid lip composition applicators, eyeliner applicators, powder applicators such as for blushers, nail varnish applicators, or hair treatment applicators, such as hair dye brushes, and possible toothbrushes.

It should be understood that the foregoing description is only illustrative of the present invention. Various alternatives and modifications can be devised by those skilled in the art without departing from the present invention. Accordingly, the present invention is intended to embrace all such alternatives, modifications and variances.

15

WHAT IS CLAIMED IS:

1. An applicator brush for applying a cosmetic comprising:

5

a handle;

a wire section extending from said handle; and

10

a brush head being connected to said wire section, said brush head having a plurality of bristles, wherein at least some of said plurality of bristles are individually formed of two or more materials.

15

2. The applicator brush of claim 1, wherein the applicator brush is a mascara brush.

20

3. The applicator brush of claim 1, wherein said two or more materials are co-extruded as a single bristle.

25

4. The applicator brush of claim 3, wherein said two or more materials are co-extruded in a form of a core and a sheath at least partially surrounding said core.

30

5. The applicator brush of claim 4, wherein said sheath is formed of a first material, and said core is formed of a second material.

6. The applicator brush of claim 5, wherein said second material is selected from the group consisting of a polymer, a nylon, a polyester, a polyethylene terephthalate, a polybutylene terephthalate, a

thermoelastic, a thermoplastic, polypropylene, and any combinations thereof.

7. The applicator brush of claim 5, wherein said
5 second material is selected from the group consisting of a nylon, a polyester, an elastomer, and any combinations thereof.

8. The applicator brush of claim 5, wherein said
10 first material is selected from the group consisting of a polymer, a nylon, a polyester, a polyethylene terephthalate, a polybutylene terephthalate, a thermoelastic, a thermoplastic, polypropylene, and any combinations thereof.

15

9. The applicator brush of claim 5, wherein said first material is selected from the group consisting of a nylon, a polyester, an elastomer, and any combinations thereof.

20

10. The applicator brush of claim 4, wherein said core is made of nylon or polyester, and wherein said sheath is made of thermoplastic elastomer.

25

11. The applicator brush of claim 4, wherein said core is made of a thermoplastic elastomer, and wherein said sheath is made of nylon or polyester.

30

12. The applicator brush of claim 4, wherein said core is fully surrounded by said sheath.

13. The applicator brush of claim 12, wherein said core is a longitudinal band that extends along a

longitudinal axis of each of said at least some of said plurality of bristles.

14. The applicator brush of claim 1, wherein each
5 of said at least some of said plurality of bristles has a surface having one or more features selected from the group consisting of one or more indentations, one or more cavities, one or more protuberances, one or more split ends, and any combinations thereof.

10

15. The applicator brush of claim 14, wherein at least some of said one or more features stores one or more additives selected from the group consisting of a germicidal powder, a mascara, a cosmetic medium, a dye,
15 a hair care product, a hair growth stimulating product, a combing gel, a lubricant, and any combinations thereof.

16. The applicator brush of claim 1, wherein each
20 of said at least some of said plurality of bristles has a cross section having a shape selected from the group consisting of a rectangle, a square, a toroidal, a triangle, a polyhedron, and any combinations thereof.

25 17. The applicator brush of claim 1, wherein each of said at least some of said plurality of bristles has one or more pyramid shaped edges.

18. The applicator brush of claim 1, wherein each
30 of said at least some of said plurality of bristles has an antibacterial additive disposed thereon or therein.

19. An applicator brush for applying mascara to eyelashes comprising:

a handle;

a wire section extending from said handle; and

5

a brush head being connected to said wire section, said brush head having a plurality of bristles, wherein at least some of said plurality of bristles have a structural surface feature selected from the group consisting of one or more indentations, one or more cavities, one or more split ends, one or more protuberances, and any combinations thereof.

10

20. The applicator brush of claim 19, wherein said one or more indentations or cavities store and release one or more additives selected from the group consisting of a germicidal powder, mascara, cosmetic medium, dye, hair care product, hair growth stimulating product, combing gel, lubricant, and any combinations thereof.

20

21. The applicator brush of claim 19, wherein said at least some of said plurality of bristles has an antibacterial additive disposed thereon or therein.

25

22. The applicator brush of claim 19, wherein said at least some of said plurality of bristles has a core and a sheath at least partially surrounding said core.

30

23. The applicator brush of claim 22, wherein said core and said sheath are individually made of a material selected from the group consisting of a polymer, a nylon, a polyester, a polyethylene

terephthalate, a polybutylene terephthalate, a thermoelastic, a thermoplastic, a polypropylene, and any combinations thereof, and wherein said core material is different from said sheath material.

5

24. An applicator brush for applying mascara to eyelashes comprising:

a handle;

10

a wire section extending from said handle; and

15

a brush head being connected to said wire section, said brush head having a plurality of bristles, wherein at least some of said plurality of bristles have a shape selected from the group consisting of a square, a rectangle, a toroidal, a triangle, a polyhedron, and any combinations thereof.

20

25. The applicator brush of claim 24, wherein said at least some of said plurality of bristles has pyramid shaped edges.

25

26. The applicator brush of claim 24, wherein said at least some of said plurality of bristles has one or more edges shaped substantially as a polyhedron.

30

27. The applicator brush of claim 24, wherein said at least some of said plurality of bristles has an antibacterial additive disposed thereon or therein.

28. The applicator brush of claim 24, wherein said at least some of said plurality of bristles have one or more surface features selected from the group

consisting of one or more indentations, one or more cavities, one or more protuberances, one or more split ends, and any combinations thereof.

5 29. The applicator brush of claim 24, wherein said at least some of said plurality of bristles has a core and a sheath at least partially surrounding said core. .

10 30. The applicator brush of claim 29, wherein said core and said sheath are individually made of a material selected from the group consisting of a
polymer, a nylon, a polyester, a polyethylene
terephthalate, a polybutylene terephthalate, a
15 thermoelastic, a thermoplastic, a polypropylene, and any combinations thereof, and wherein said core material is different from said sheath material.

20 31. An applicator brush for applying mascara to eyelashes comprising:

a handle;

a wire section extending from said handle; and

25 a brush head being connected to said wire section, said brush head having a plurality of bristles, wherein at least some of said plurality of bristles are individually formed of a core and a sheath at least
30 partially surrounding said core.

32. The applicator brush of claim 31, wherein said core is made of a material selected from the group consisting of a thermoplastic, a thermoelastic, a

nylon, a polyester, and any combinations thereof, and wherein said sheath is a yarn.

33. The applicator brush of claim 32, wherein
5 said sheath fully surrounds said core.

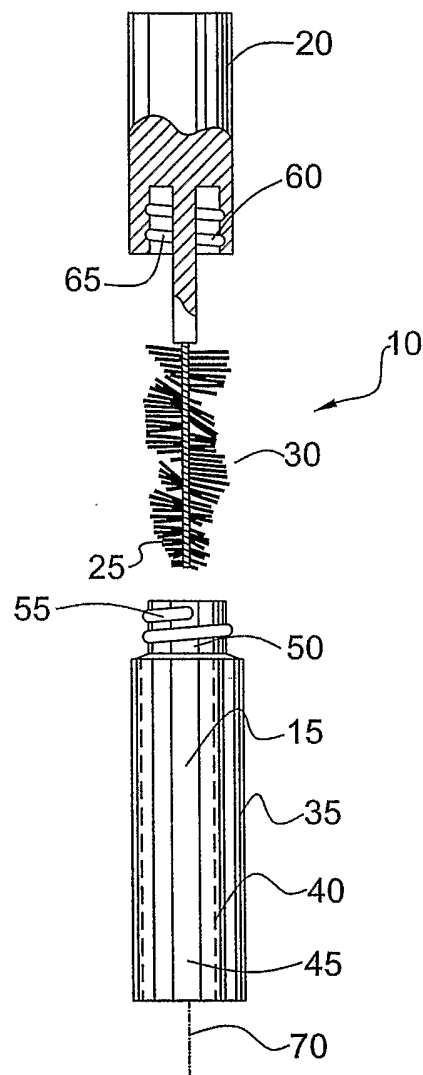

Fig. 1

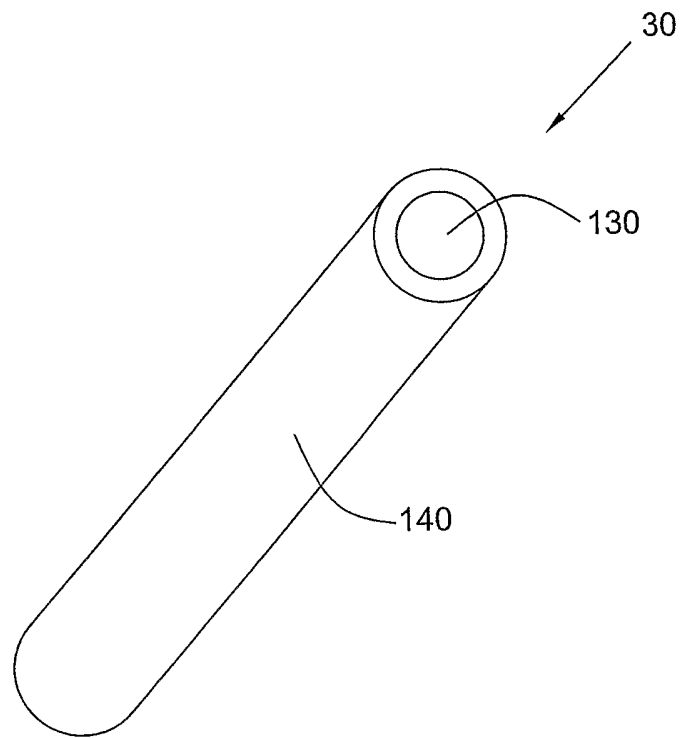

Fig. 2

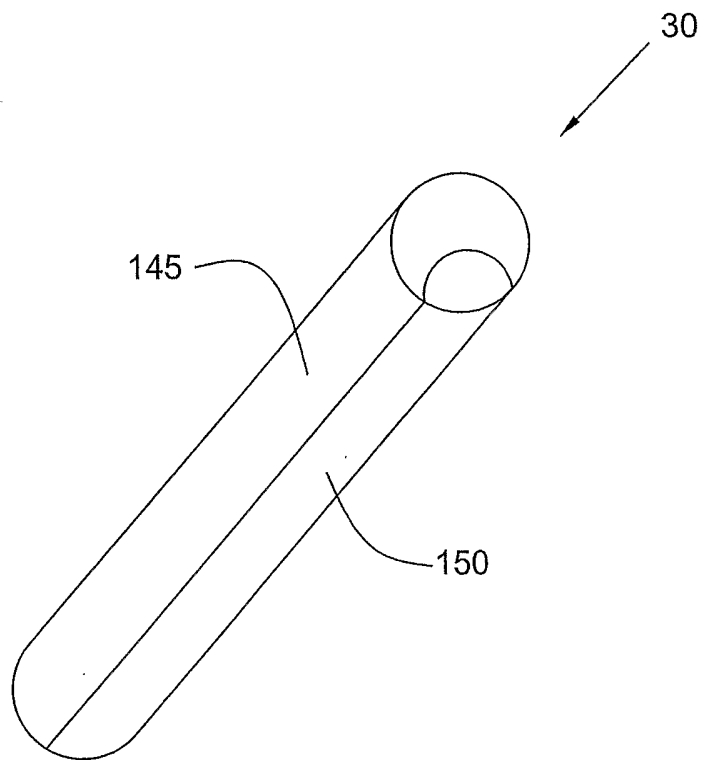

Fig. 3

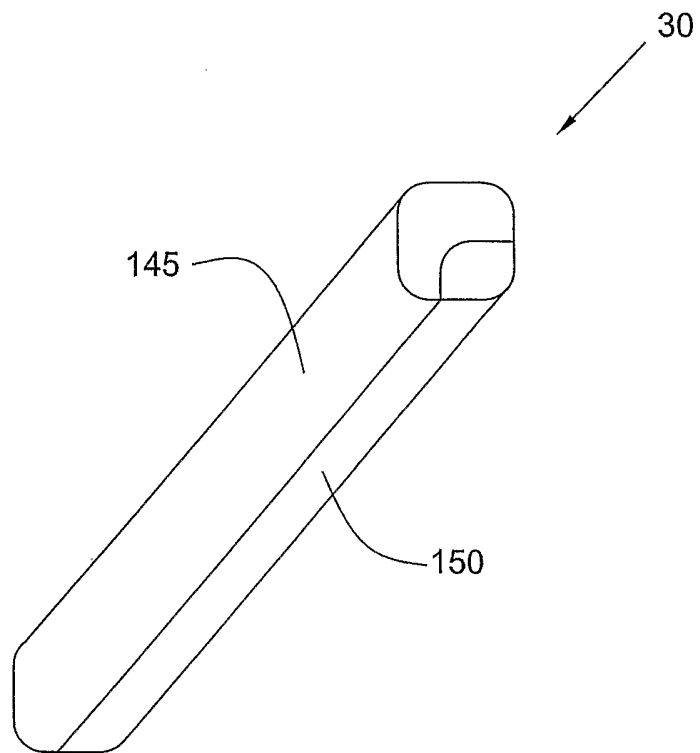

Fig. 4

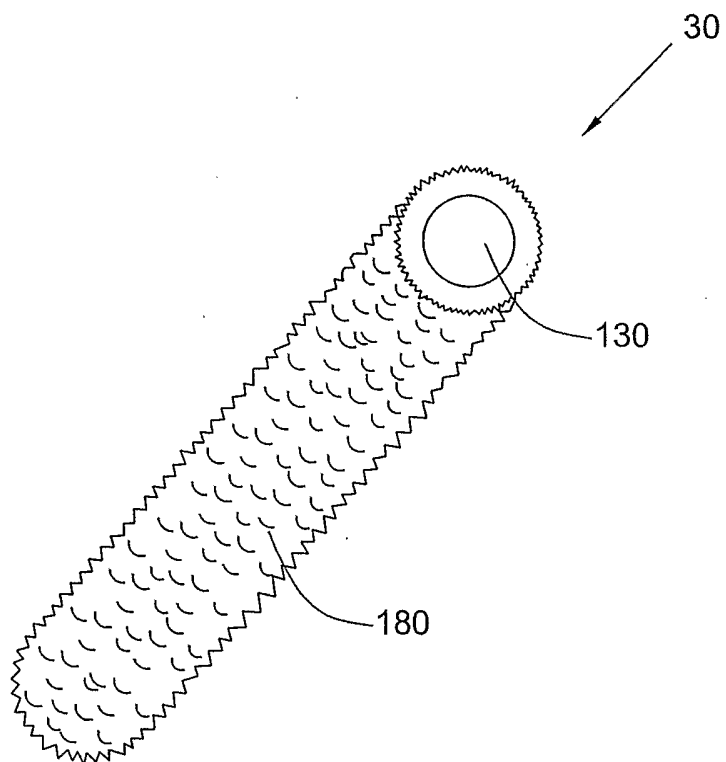

Fig. 5

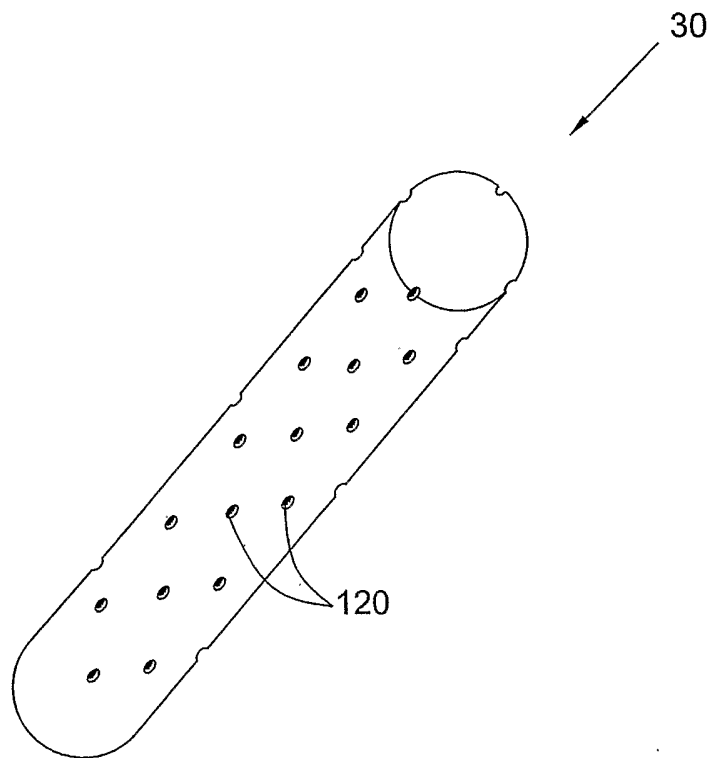

Fig. 6

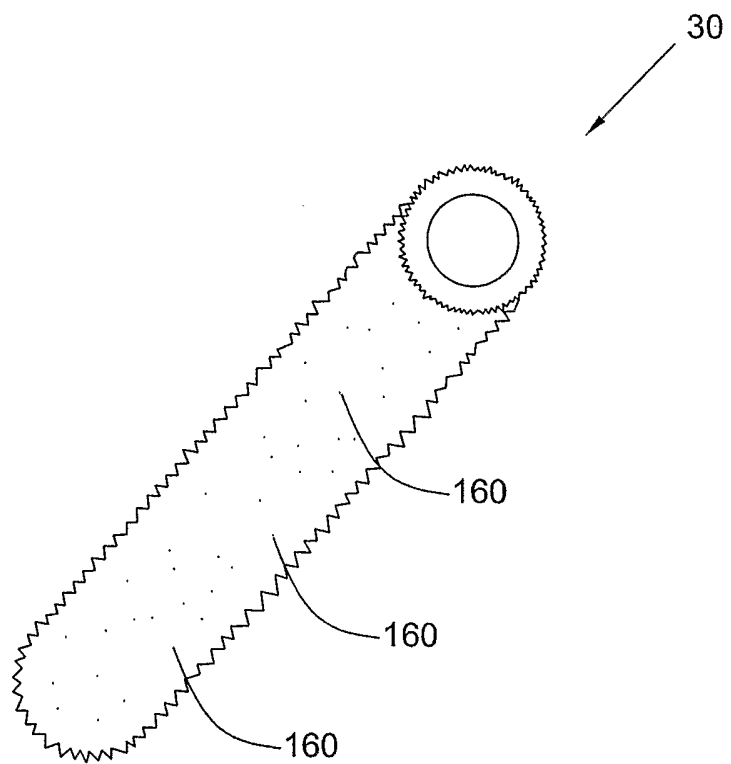

Fig. 7

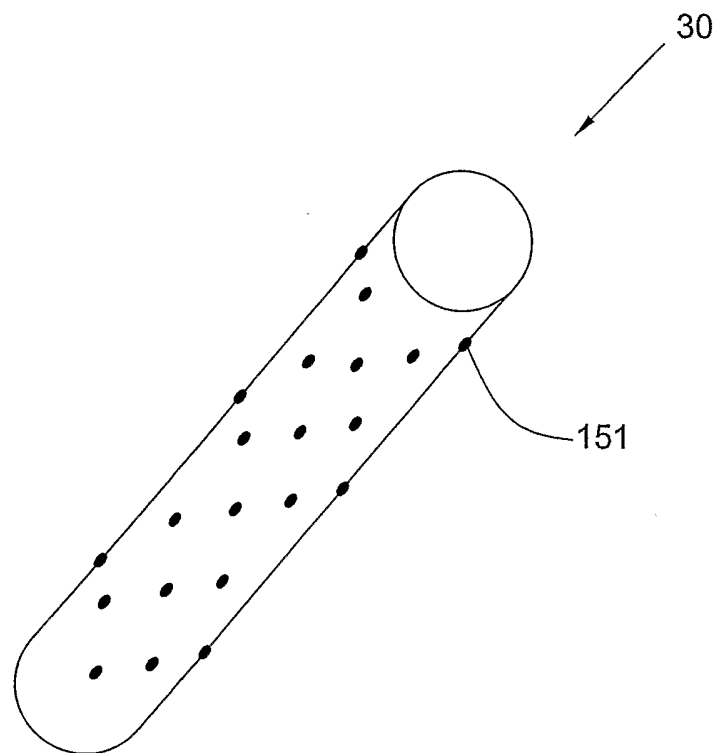

Fig. 8

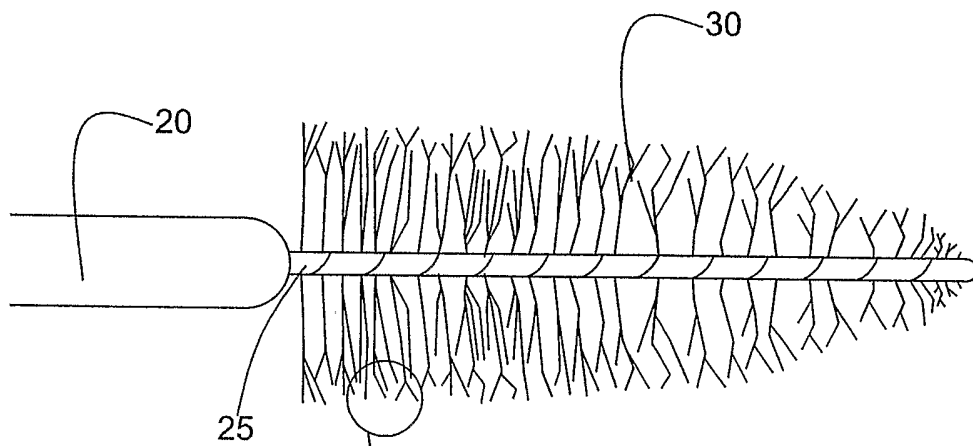

Fig. 9

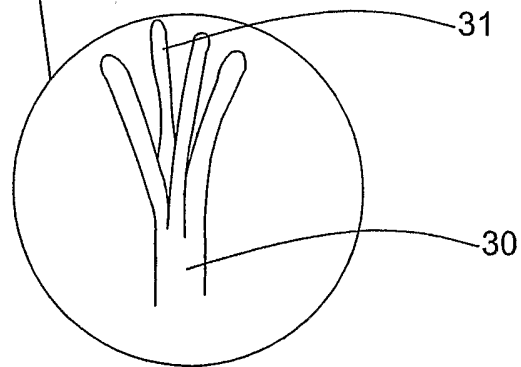

Fig. 10

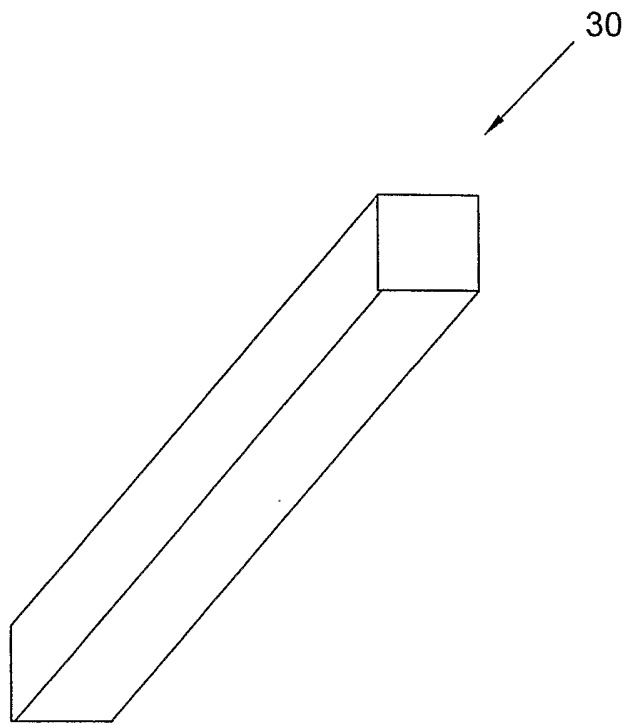

Fig. 11

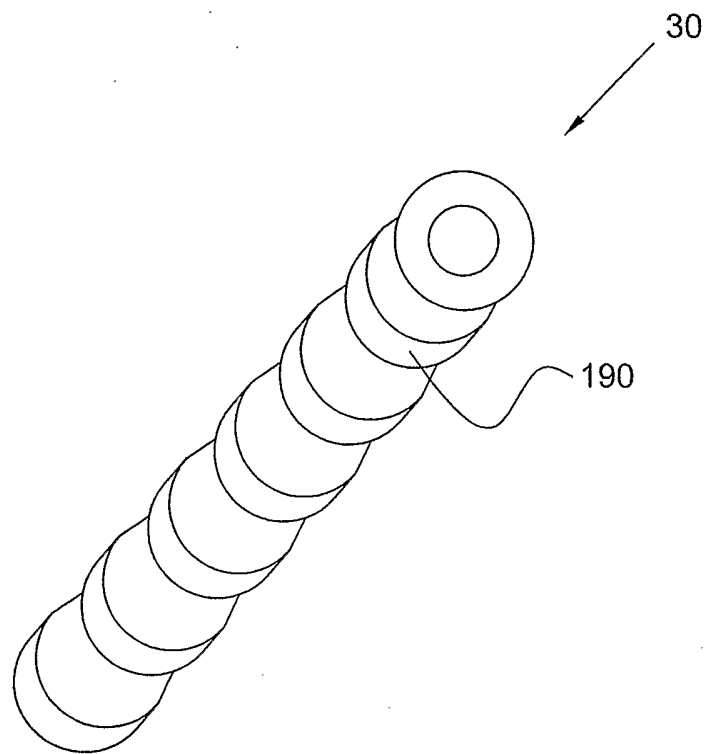

Fig. 12

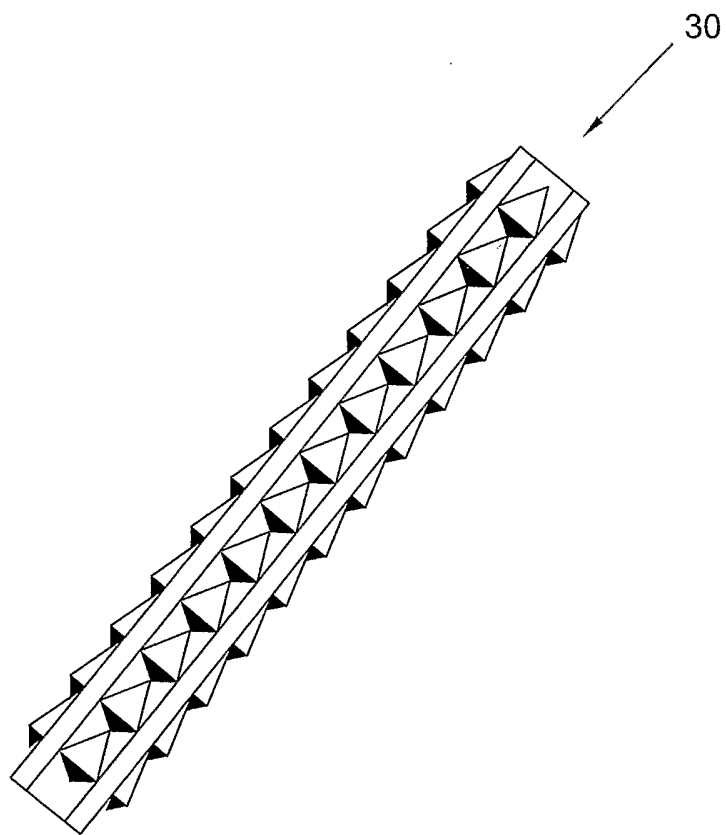

Fig. 13

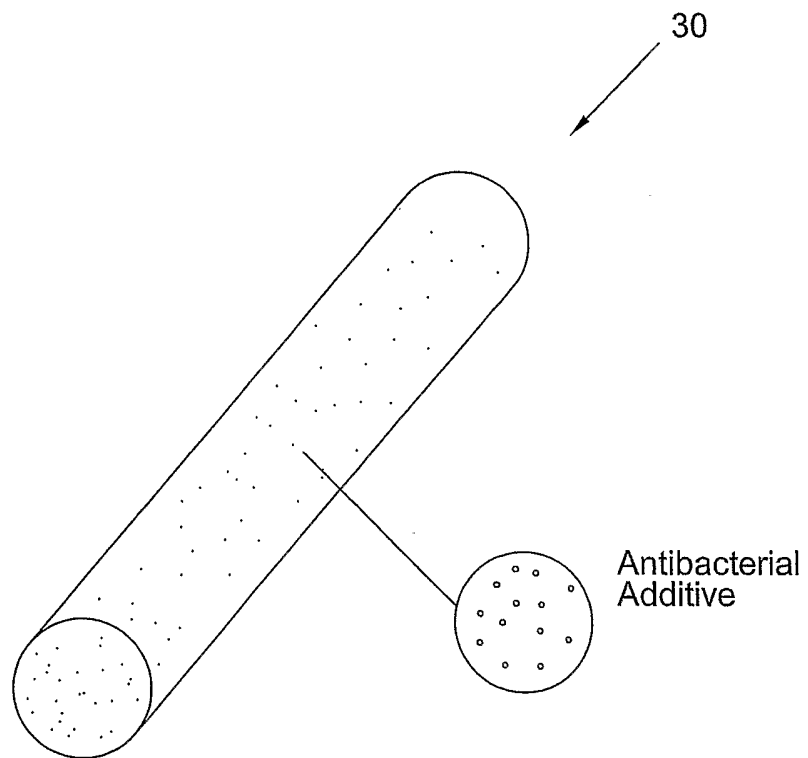

Fig. 14