

(19) World Intellectual Property Organization
International Bureau



(43) International Publication Date
8 November 2007 (08.11.2007)

PCT

(10) International Publication Number
WO 2007/125345 A1

(51) International Patent Classification:
B41J 2/16 (2006.01)

(21) International Application Number:
PCT/GB2007/001567

(22) International Filing Date: 27 April 2007 (27.04.2007)

(25) Filing Language: English

(26) Publication Language: English

(30) Priority Data:
0608526.0 28 April 2006 (28.04.2006) GB

(71) Applicant (for all designated States except US): **XAAR TECHNOLOGY LIMITED** [GB/GB]; Science Park, Cambridge Cambs CB4 0XR (GB).

(72) Inventor; and

(75) Inventor/Applicant (for US only): **BRÜNAHL, Jürgen** [DE/GB]; 62 Water Street, Cambridge, CB4 1PA (GB).

(74) Agents: **GARRATT, Peter, Douglas** et al.; Mathys & Squire, 120 Holborn, London EC1N 2SQ (GB).

(81) Designated States (unless otherwise indicated, for every kind of national protection available): AE, AG, AL, AM,

AT, AU, AZ, BA, BB, BG, BH, BR, BW, BY, BZ, CA, CH, CN, CO, CR, CU, CZ, DE, DK, DM, DZ, EC, EE, EG, ES, FI, GB, GD, GE, GH, GM, GT, HN, HR, HU, ID, IL, IN, IS, JP, KE, KG, KM, KN, KP, KR, KZ, LA, LC, LK, LR, LS, LT, LU, LY, MA, MD, MG, MK, MN, MW, MX, MY, MZ, NA, NG, NI, NO, NZ, OM, PG, PH, PL, PT, RO, RS, RU, SC, SD, SE, SG, SK, SL, SM, SV, SY, TJ, TM, TN, TR, TT, TZ, UA, UG, US, UZ, VC, VN, ZA, ZM, ZW.

(84) Designated States (unless otherwise indicated, for every kind of regional protection available): ARIPO (BW, GH, GM, KE, LS, MW, MZ, NA, SD, SL, SZ, TZ, UG, ZM, ZW), Eurasian (AM, AZ, BY, KG, KZ, MD, RU, TJ, TM), European (AT, BE, BG, CH, CY, CZ, DE, DK, EE, ES, FI, FR, GB, GR, HU, IE, IS, IT, LT, LU, LV, MC, MT, NL, PL, PT, RO, SE, SI, SK, TR), OAPI (BF, BJ, CF, CG, CI, CM, GA, GN, GQ, GW, ML, MR, NE, SN, TD, TG).

Published:

- with international search report
- before the expiration of the time limit for amending the claims and to be republished in the event of receipt of amendments

For two-letter codes and other abbreviations, refer to the "Guidance Notes on Codes and Abbreviations" appearing at the beginning of each regular issue of the PCT Gazette.



WO 2007/125345 A1

(54) Title: DROPLET DEPOSITION COMPONENT

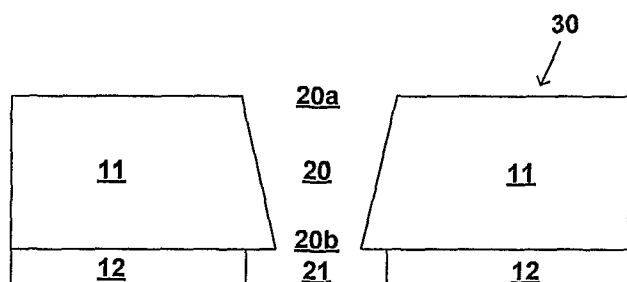

(57) Abstract: A method of forming a nozzle plate component (30) for a printhead comprising the steps of: providing a laminar body having a polymeric upper layer (11) defining a top surface and a metal lower layer (12) defining a bottom surface; removing material by ablation or photolithography from the polymeric layer to selectively expose the metal layer; and applying etchant from the top surface that selectively etches the exposed areas of the metal layer, thereby undercutting said upper layer to form a recess area 21 in the metal layer and forming an opening through said body (20, 21).

DROPLET DEPOSITION COMPONENT

The present invention relates to a component for a droplet deposition apparatus, and more particularly a nozzle plate for a droplet deposition apparatus. The present invention finds particular application in the field of drop on demand ink jet printing.

5 It is known to provide a composite nozzle plate, that is to say a nozzle plate formed of more than one material. WO 02/98666 for example describes a nozzle plate having a body containing a series of apertures, the apertures filled with a polymer through which nozzles are formed.

10 WO 05/14292 describes an alternative type of manufacture for a nozzle plate of the kind described in WO 02/98666, whereby an array of distinct polymeric bodies are formed first, around which a metallic plate is formed. Nozzles are then formed through the polymeric bodies.

15 These prior art constructions are complex to manufacture, requiring a large number of steps. Such constructions can also suffer the problem of poor bonding between the plate and the polymeric insert.

It is an object of the present invention to provide an improved nozzle plate component and method of manufacture.

20 According to a first aspect of the invention there is provided a method of forming a nozzle plate component for a droplet deposition apparatus comprising providing a body having a polymeric upper layer defining a top surface, and a metal lower layer defining a bottom surface; selectively removing material from said upper layer to selectively expose said lower layer; and processing from said top surface exposed areas of said lower layer to selectively remove material from said lower layer, thereby forming an opening through said body.

25 By initially providing a laminated body, it is possible to provide a very strong bond between the metal and polymer layers.

30 Material can be removed from the upper layer to form an essentially completed nozzle, or to form a pilot hole, to be finished into a nozzle with a subsequent processing step. By removing material from said lower layer by processing from the top surface, features in the lower layer are spatially defined

by the form of the processed upper layer. Thus although the two layers are processed in separate stages, registration between the layers is easily achieved.

In one embodiment the polymer is SU-8 photoresist and the metal is nickel.

5 SU-8 is a photoresist developed by IBM, and described in US 4882245.

The main advantages of SU-8 are that it is:

- photoimageable
- chemically inert and temperature stable
- laser ablateable at increased rate
- 10 - widely used in MEMS production
- transparent

The main manufacturing process for SU-8 sheets is spin coating. Film thicknesses ranging from 1micron to 1mm are readily achievable.

15 Although plain SU-8 is transparent and brittle, which makes it difficult to handle, according to the present invention it is utilised in combination with a nickel layer, thus a flexible and non-transparent laminate suitable for nozzle plate manufacture is provided. The nozzle of the completed nozzle plate is recessed into an opening in the nickel film, the nickel acting as a protective layer to make the nozzle plate scratch resistant.

20 According to a second aspect of the invention there is provided a nozzle plate component for a droplet deposition apparatus comprising a body having a polymeric upper layer defining a top surface, and a metal lower layer defining a bottom surface; a nozzle formed in said upper layer having an inlet in said top surface and an outlet intermediate said top and bottom surfaces, and a recess
25 formed in said bottom layer extending around said nozzle outlet.

Preferably the component is formed by processing a blank having a polymeric upper layer and a metal lower layer.

30 According to a third aspect of the invention there is provided a method of forming a nozzle plate component for a droplet deposition apparatus, the nozzle plate component comprising at least one nozzle formed in a first layer of the nozzle plate component and, in axial registration with each nozzle, a respective

opening formed in a second layer of the nozzle plate component, which opening is at the abutting surfaces of the first and second layers of greater radial extent than the nozzle, the method comprising the steps of:

providing a nozzle plate laminate having a first layer and a second layer;

5 forming an aperture in the first layer in a first forming process; and

forming an opening in the second layer in a second forming process, different from the first forming process, the location of the opening in the second forming process being determined by the location of the aperture in the first layer;

10 the aperture in the first layer with optional further processing serving as the nozzle.

The invention will now be described by way of an example with reference to the accompanying drawings in which:

Figure 1 illustrates a composite body or blank

15 Figure 2 shows a desired nozzle shape configuration according to an aspect of the present invention.

Figure 3 illustrates a manufacturing process according to an aspect of the present invention

20 Figure 4 illustrates an alternative manufacturing process according to an aspect of the present invention

Figure 5 illustrates a variation of the process of Figure 4

25 Figure 1 illustrates a composite body formed of a plurality of layers. A release layer 13 is built-up on a re-usable substrate 14, facilitating removal of the processed nozzle plate, followed by the lower layer 12 of the nozzle plate – here a nickel layer – and finally the upper layer of the nozzle plate 11 on top – here a layer of SU8 or polymer.

30 A number of examples of process steps will now be described which result in the desired nozzle plate construction as shown in Figure 2. As displayed here, the nozzle plate component has a nozzle bore 20 extending through the upper layer 11, which tapers in diameter from the nozzle inlet 20a to the nozzle outlet

20b. There is a recess area 21 formed in the lower layer 12, which as mentioned above, protects the upper layer 11 from mechanical abrasion.

In Figure 3a, the upper layer 11 is of photoresist and undergoes a photolithographic exposure and development process to produce a nozzle bore
5 20. A variety of suitable photolithographic processes are known in the art, 'Fabrication of 3D Microstructures with Inclined/Rotated UV Lithography' (Micro Electro Mechanical Systems, Kyoto 2003, pages 554 – 557) describes the creation in SU-8 of several appropriate nozzle structures including truncated
10 cones. 'Microfabrication of 3D Multidirectional Inclined Structures by UV Lithography and Electroplating' (Micro Electro Mechanical Systems 1994 Proceedings, pages 81-85, IEEE Workshop) describes a further method of creating structures in positive photoresist. These or other processes can readily provide a nozzle bore having a tapered profile with a taper angle from 0 to approximately 15 degrees. Depending on the photolithographic method used, the
15 upper layer of photoresist 11 may then undergo a post exposure bake. Suitable photolithographic processes can advantageously be used to form a large number of nozzles simultaneously.

An etching process is then applied to the body from the top surface, as shown in Figure 3b. This locally removes part of the nickel layer 12 around the
20 nozzle outlet to form a recess area 21. As shown, the nickel layer 12 is undercut by the etching procedure such that the nickel layer does not affect droplets ejected from the nozzle outlet 20b. An isotropic etchant may advantageously be employed here to ensure the formation of the undercut. The etchant should be selective for the nickel layer 12 over the polymer layer 11.

25 As shown in Figure 3c, the finished nozzle plate component 30 is released from the substrate 14, and can be hard baked if desired.

In a process similar to that of Figure 3, a laser can be used to process the upper layer 11 rather than a photolithographic process.

30 In such a process nozzle bores 20 are formed by *ex-situ* laser ablation, where ablation is carried out on the nozzle plate component 30 before attachment to the printhead. During this process the nickel layer 12 acts as a stop as its ablation rate is far lower than the upper layer 11, which is typically polymeric. Again, the lower layer 12 is etched through the completed nozzle bore 20 to form

the recess 21, and the finished nozzle plate component 30 released from the substrate 14.

Figure 4 illustrates a method which allows nozzle bores 20 to be formed in the upper layer 11 by laser ablation, subsequent to etching the lower layer 12.

5 In Figure 4a, a small opening or pilot hole 23 is formed into the polymer layer by means of photolithography. The diameter of the openings 23 is smaller than the nozzles 20 formed by the subsequent laser ablation step.

Figure 4b illustrates etching of the metal layer through the pilot hole, to form a recess where the nozzle outlet is to be formed. The nozzle is then formed
10 by laser ablation from the top surface, as shown in Figure 4c. In this way, the lip of the nozzle outlet 20b is formed free from any contact with the nickel layer 12, but with the substrate 14 providing support to maintain a flat surface.

Figure 4d shows the finished nozzle plate component 30 separated from the substrate 14.

15 Figure 5 illustrates a variation of the embodiment of Figure 4 in which the nozzles are defined by *in-situ* ablation – ablation following attachment of the nozzle plate to the printhead.

Figures 5a and 5b illustrate formation of a small pilot hole 23 and subsequent metal etching as shown in Figures 4a and 4b.

20 At this stage the nozzle plate is released from the substrate 14 as shown in Figure 5c, and is attached to the printhead, as shown in Figure 5d by attachment to PZT walls 15. The assembled structure can advantageously be coated with Parylene at this stage, which serves the dual function of passivating the channel interior 24, and providing a protective coating on the outer surface of
25 the nozzle plate in preparation for ablation. The nozzle bores 20 are then formed by laser ablation from the bottom side of the body.

It will be understood that this invention has been described by way of example only and that a wide variety of modifications are possible without departing from the scope of the invention. For example, the etching process may
30 utilise a liquid or plasma-phase etchant, of which many types are known. Further, a wide variety of suitable materials will be apparent to those skilled in the art. The upper layer may comprise a variety of polymers susceptible to photolithography or ablation, whilst the lower layer may comprise a variety of

etchable or fluid processable materials including other metals, and substrate materials used in flexible circuit board manufacture.

CLAIMS

1. A method of forming a nozzle plate component for a droplet deposition apparatus comprising the steps of:
 - providing a body having a polymeric upper layer defining a top surface, and a lower layer defining a bottom surface;
 - removing material from said upper layer to selectively expose said lower layer in a first process; and
 - processing from said top surface exposed areas of said lower layer to selectively remove material from said lower layer in a second process, thereby forming an opening through said body.
2. A method according to Claim 1 wherein said second process operates selectively upon said lower layer.
3. A method according to Claims 1 or 2 wherein said second process undercuts said polymeric layer.
4. A method according to Claim 1 wherein said first process operates selectively upon said polymeric layer.
5. A method according to any one of Claims 1 to 4, wherein said second process comprises introducing a fluid through apertures in said upper layer created by said first process.
6. A method according to any one of Claims 1 to 5, wherein selectively removing material from said upper layer comprises forming a nozzle in said upper layer.
7. A method according to any one of Claims 1 to 6, wherein selectively removing material from said upper layer results in a pilot hole in said upper layer, and subsequently comprising forming a nozzle in said upper layer around said pilot hole.
8. A method according to Claim 7, wherein said nozzle is formed by processing from said top surface.

9. A method according to Claim 7, wherein said nozzle is formed by processing from said bottom surface.
10. A method according to any one of Claims 6 to 9, wherein the inlet of said nozzle is formed in said top surface.
11. A method according to any one of the preceding claims, wherein selectively removing material from said lower layer results in a recess in said body at said nozzle outlet.
12. A method according to Claim 11, wherein the recessed area is greater than the area of the outlet of said nozzle.
13. A method according to any one of Claims 1 to 8, wherein said body is provided releasably attached to a base layer
14. A method according to any one of the preceding claims, wherein said upper layer is SU-8
15. A method according to any one of the preceding claims, wherein said lower layer is a metal.
16. A method according to any one of the preceding claims, wherein said lower layer is nickel
17. A method according to any one of the preceding claims, wherein selectively removing material from said upper layer is performed by photolithographic processing.
18. A method according to any one of the preceding claims, wherein said photolithographic processing results in a tapered aperture in said upper layer.

19. A method according to any one of the preceding claims, wherein selectively removing material from said upper layer is performed by laser ablation.
20. A method according to any one of the preceding claims, wherein processing said lower layer to remove material comprises etching.
21. A nozzle plate component for a droplet deposition apparatus comprising
 - a body having a polymeric upper layer defining a top surface, and a metal lower layer defining a bottom surface;
 - a nozzle formed in said upper layer having an inlet in said top surface and an outlet intermediate said top and bottom surfaces;
 - and
 - a recess formed in said bottom layer extending around said nozzle outlet.
22. A nozzle plate component according to Claim 21, wherein said component is formed by processing a blank having a polymeric upper layer and a metal lower layer.
23. A method of forming a nozzle plate component for a droplet deposition apparatus, the nozzle plate component comprising at least one nozzle formed in a first layer of the nozzle plate component and, in axial registration with each nozzle, a respective opening formed in a second layer of the nozzle plate component, which opening is at the abutting surfaces of the first and second layers of greater radial extent than the nozzle, the method comprising the steps of:
 - providing a nozzle plate laminate having a first layer and a second layer;
 - forming an aperture in the first layer in a first forming process; and
 - forming an opening in the second layer in a second forming process, different from the first forming process, the location of the opening in the second forming process being determined by the location of the aperture in the first layer;

the aperture in the first layer with optional further processing serving as the nozzle.

24. A method according to Claim 23, wherein the second forming process includes the passage through the aperture of a material removal agent.
25. A method according to Claim 23, wherein the material removal agent is an etchant for the material of the second layer.
26. A method according to any one of Claims 23 to 25, wherein the first forming process comprises laser ablation.
27. A method according to any one of Claims 23 to 25, wherein the first layer is formed of polymeric material and the second layer is formed of metal.
28. A method according to any one of Claims 23 to 25, wherein the formed nozzle tapers in radial extent in the axial direction toward the second layer.

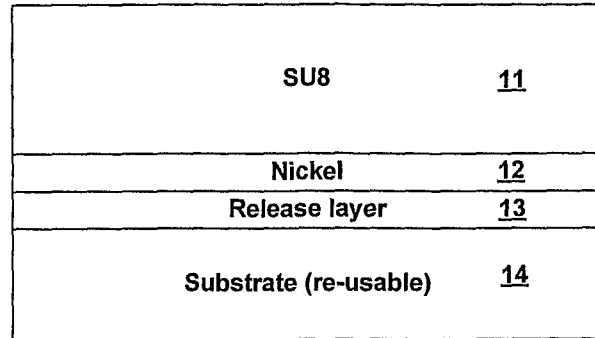

Figure 1

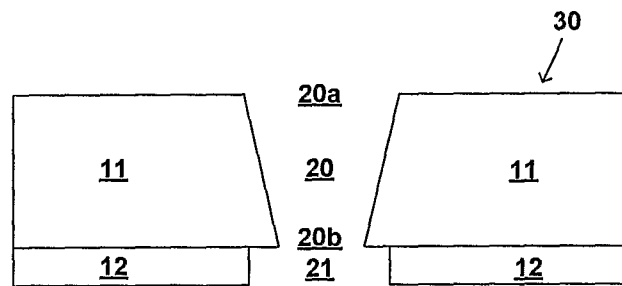

Figure 2

2/4

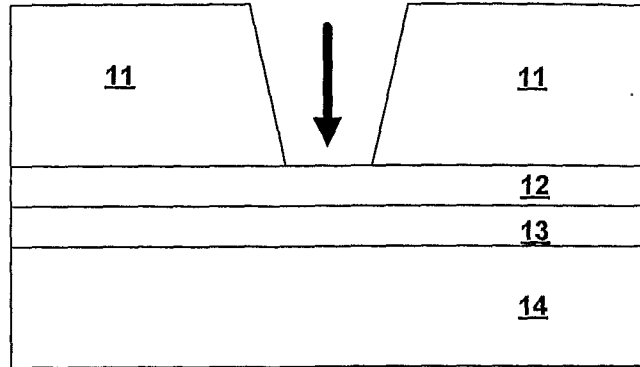

Figure 3a

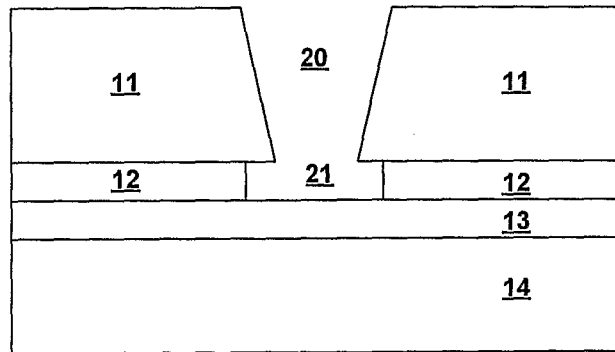

Figure 3b

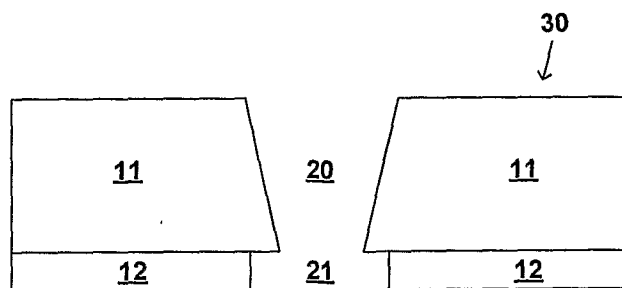

Figure 3c

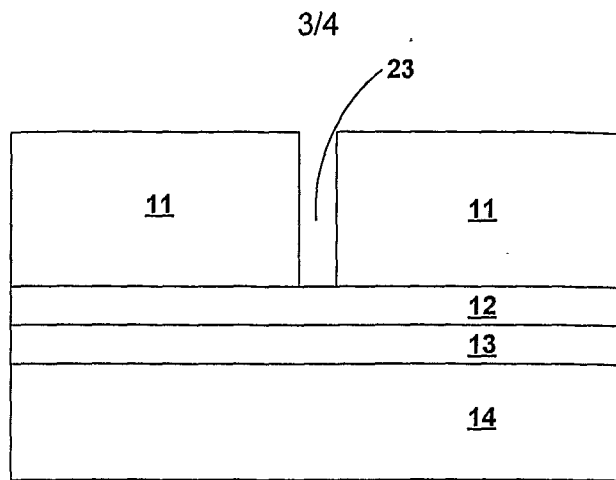

Figure 4a

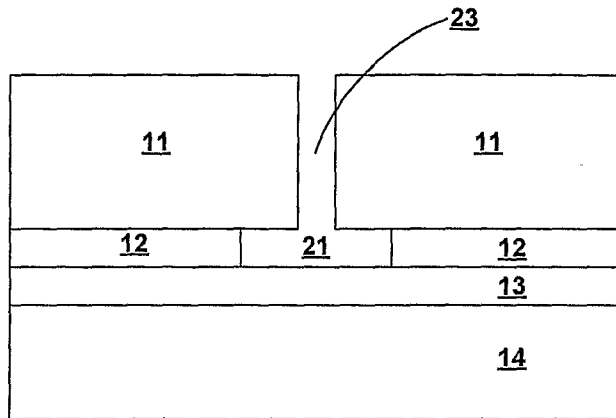

Figure 4b

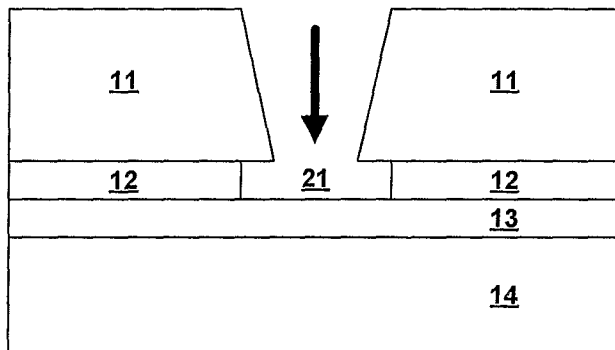

Figure 4c

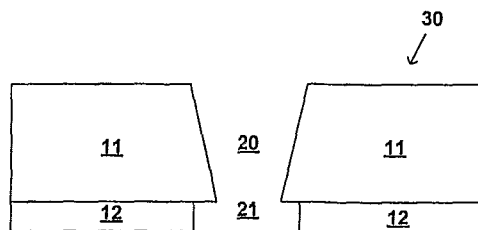

Figure 4d

4/4

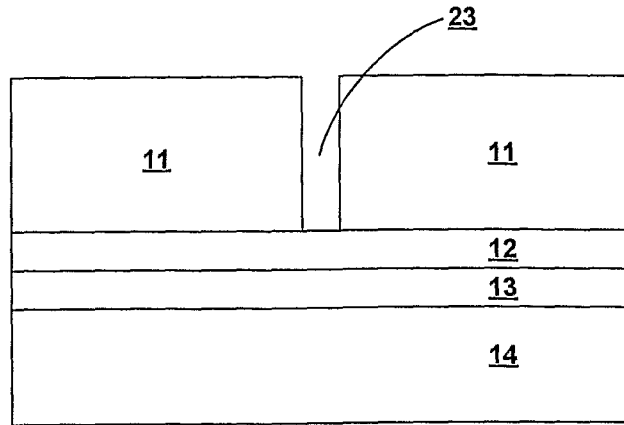

Figure 5a

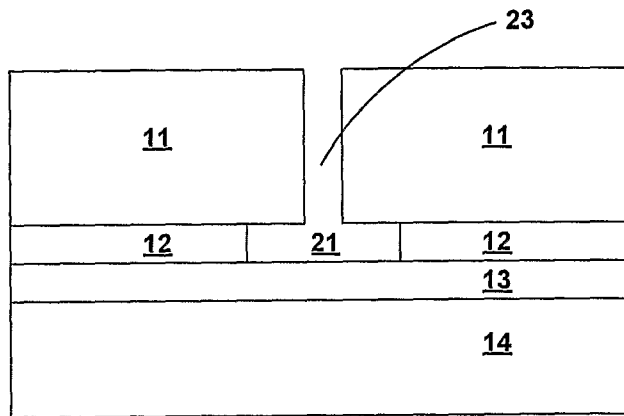

Figure 5b

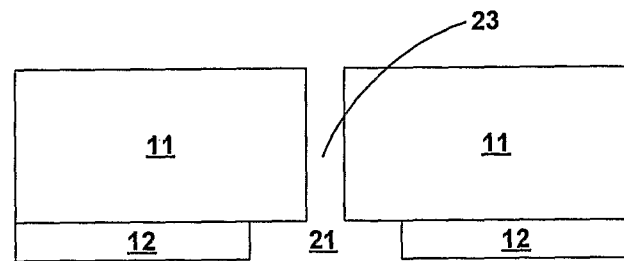

Figure 5c

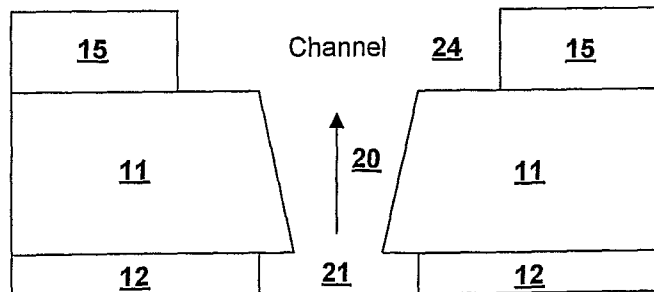

Figure 5d

INTERNATIONAL SEARCH REPORT

International application No
PCT/GB2007/001567

A. CLASSIFICATION OF SUBJECT MATTER
INV. B41J2/16

According to International Patent Classification (IPC) or to both national classification and IPC

B. FIELDS SEARCHED

Minimum documentation searched (classification system followed by classification symbols)
B41J

Documentation searched other than minimum documentation to the extent that such documents are included in the fields searched

Electronic data base consulted during the international search (name of data base and, where practical, search terms used)

EPO-Internal, WPI Data

C. DOCUMENTS CONSIDERED TO BE RELEVANT

Category*	Citation of document, with indication, where appropriate, of the relevant passages	Relevant to claim No.
X	EP 1 027 992 A (CANON KK [JP]) 16 August 2000 (2000-08-16) paragraphs [0050], [0067], [0074]; figure 10	1-28
X	US 2003/145464 A1 (LINLIU KUNG [TW] ET AL) 7 August 2003 (2003-08-07) paragraph [0015]; figure 1d.1e	1-28
X	WO 2005/014292 A (XAAR TECHNOLOGY LTD [GB]; DRURY PAUL RAYMOND [GB]) 17 February 2005 (2005-02-17) cited in the application page 5, lines 8-19; figure 3c	21-28
X	US 2004/041883 A1 (EIDA MASATAKA [JP] ET AL) 4 March 2004 (2004-03-04) figures 1a-e	1-28
	----- -/--	

Further documents are listed in the continuation of Box C.

See patent family annex.

* Special categories of cited documents :

- *A* document defining the general state of the art which is not considered to be of particular relevance
- *E* earlier document but published on or after the international filing date
- *L* document which may throw doubts on priority claim(s) or which is cited to establish the publication date of another citation or other special reason (as specified)
- *O* document referring to an oral disclosure, use, exhibition or other means
- *P* document published prior to the international filing date but later than the priority date claimed

- *T* later document published after the international filing date or priority date and not in conflict with the application but cited to understand the principle or theory underlying the invention
- *X* document of particular relevance; the claimed invention cannot be considered novel or cannot be considered to involve an inventive step when the document is taken alone
- *Y* document of particular relevance; the claimed invention cannot be considered to involve an inventive step when the document is combined with one or more other such documents, such combination being obvious to a person skilled in the art.
- *G* document member of the same patent family

Date of the actual completion of the international search

21 August 2007

Date of mailing of the international search report

03/09/2007

Name and mailing address of the ISA/
European Patent Office, P.B. 5618 Patentlaan 2
NL - 2280 HV Rijswijk
Tel. (+31-70) 340-2040, Tx. 31 651 epo nl,
Fax: (+31-70) 340-3016

Authorized officer

Christen, Jérôme

INTERNATIONAL SEARCH REPORT

International application No
PCT/GB2007/001567

C(Continuation). DOCUMENTS CONSIDERED TO BE RELEVANT		
Category*	Citation of document, with indication, where appropriate, of the relevant passages	Relevant to claim No.
X	US 6 171 510 B1 (LEE WILLIAM T [US]) 9 January 2001 (2001-01-09) figures 1g-j -----	1-28

INTERNATIONAL SEARCH REPORT

Information on patent family members

International application No PCT/GB2007/001567

Patent document cited in search report	Publication date	Publication date	Patent family member(s)	Publication date
EP 1027992	A	16-08-2000	US 6447984 B1	10-09-2002
US 2003145464	A1	07-08-2003	TW 589253 B	01-06-2004
WO 2005014292	A	17-02-2005	AU 2004263351 A1	17-02-2005
			BR PI0412875 A	03-10-2006
			CA 2533137 A1	17-02-2005
			CN 1849216 A	18-10-2006
			EP 1646503 A2	19-04-2006
			JP 2006528093 T	14-12-2006
			KR 20060036100 A	27-04-2006
			US 2007000785 A1	04-01-2007
US 2004041883	A1	04-03-2004	NONE	
US 6171510	B1	09-01-2001	US 6557967 B1	06-05-2003