

(19) World Intellectual Property Organization
International Bureau



(43) International Publication Date
26 May 2006 (26.05.2006)

PCT

(10) International Publication Number
WO 2006/055695 A1

- (51) International Patent Classification:
A61B 18/04 (2006.01)
- (21) International Application Number:
PCT/US2005/041651
- (22) International Filing Date:
16 November 2005 (16.11.2005)
- (25) Filing Language: English
- (26) Publication Language: English
- (30) Priority Data:
60/628,451 16 November 2004 (16.11.2004) US
60/648,036 27 January 2005 (27.01.2005) US
- (71) Applicants and
(72) Inventors: BARRY, Robert, L. [US/US]; 13608 88th PI NE, Kirkland, WA 98034 (US). CRAN, Brian [US/US]; 10033 9th Avenue NW, Seattle, WA 98177 (US). CORCORAN, Dean [US/US]; 3411 192nd Street SE, Seattle, WA 98177 (US). LEE, Sheldon, K. [US/US]; 3408 10th Avenue West, Seattle, WA 98199 (US).
- (74) Agent: LYNCH, Edward, J.; Duane Morris LLP, One Market, Spear Tower, Suite 2000, San Francisco, CA 94105 (US).
- (81) Designated States (unless otherwise indicated, for every kind of national protection available): AE, AG, AL, AM,

AT, AU, AZ, BA, BB, BG, BR, BW, BY, BZ, CA, CH, CN, CO, CR, CU, CZ, DE, DK, DM, DZ, EC, EE, EG, ES, FI, GB, GD, GE, GH, GM, HR, HU, ID, IL, IN, IS, JP, KE, KG, KM, KN, KP, KR, KZ, LC, LK, LR, LS, LT, LU, LV, LY, MA, MD, MG, MK, MN, MW, MX, MZ, NA, NG, NI, NO, NZ, OM, PG, PH, PL, PT, RO, RU, SC, SD, SE, SG, SK, SL, SM, SY, TJ, TM, TN, TR, TT, TZ, UA, UG, US, UZ, VC, VN, YU, ZA, ZM, ZW.

(84) Designated States (unless otherwise indicated, for every kind of regional protection available): ARIPO (BW, GH, GM, KE, LS, MW, MZ, NA, SD, SL, SZ, TZ, UG, ZM, ZW), Eurasian (AM, AZ, BY, KG, KZ, MD, RU, TJ, TM), European (AT, BE, BG, CH, CY, CZ, DE, DK, EE, ES, FI, FR, GB, GR, HU, IE, IS, IT, LT, LU, LV, MC, NL, PL, PT, RO, SE, SI, SK, TR), OAPI (BF, BJ, CF, CG, CI, CM, GA, GN, GQ, GW, ML, MR, NE, SN, TD, TG).

Published:
— with international search report
— before the expiration of the time limit for amending the claims and to be republished in the event of receipt of amendments

For two-letter codes and other abbreviations, refer to the "Guidance Notes on Codes and Abbreviations" appearing at the beginning of each regular issue of the PCT Gazette.

(54) Title: DEVICE AND METHOD FOR LUNG TREATMENT

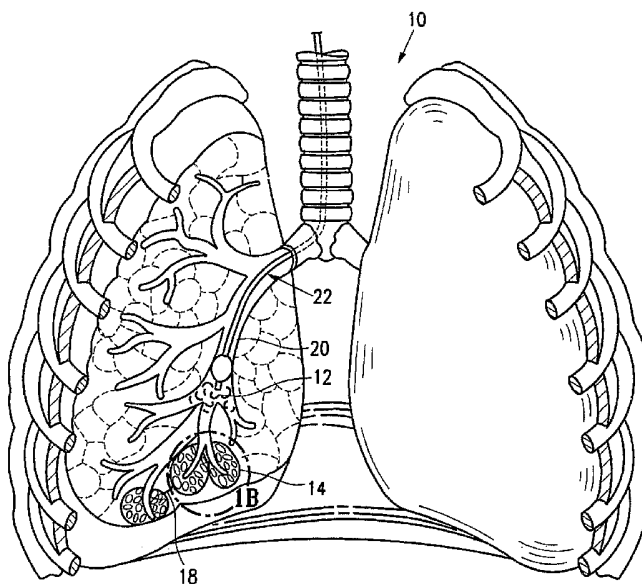

(57) Abstract: This invention relates to the treatment of a patient's lung, for example, a lung exhibiting chronic obstructive pulmonary disease (COPD) and in particular to methods and devices for affecting lung volume reduction, preferably for achieving acute or immediate lung volume reduction following treatment. The lung volume reduction is effected by delivering a condensable vapor at a temperature above body temperature to the desired regions of the patient's lung to damage tissue therein. Blood flow and air flow to the damaged tissue region is essentially terminated, rendering the target region non-functional. Alternative energy sources may be used to effect the thermal damage to the lung tissue.

WO 2006/055695 A1

DEVICE AND METHOD FOR LUNG TREATMENT

FIELD OF THE INVENTION

[0001] The present invention relates to the treatment of a patient's lung, for example, the treatment of chronic obstructive pulmonary diseases (COPD). In particular this invention relates to systems, devices and methods for affecting lung volume reduction for the treatment of COPD, such as emphysema.

BACKGROUND OF THE INVENTION

[0002] Chronic obstructive pulmonary disease (COPD) includes chronic bronchitis and emphysema. COPD is generally characterized by airflow obstruction, which in particular limits the patient's air flow during expiration. Patients with chronic bronchitis have chronic cough with sputum production leading to obstructed expiration. In patients with emphysema, destruction of lung parenchyma can lead to loss of elastic recoil, reduced tethering of the airways, obstruction to expiration, and cough.

[0003] Lung function as well as quality of life in patients suffering with a COPD can be improved by reducing a patient's effective lung volume. One way to reduce effective lung volume is by surgically removing diseased portions of the lungs, both to promote expansion of the non-diseased regions, realign a patient's diaphragm and to redirect inhaled air from diseased portions of lungs into healthier, better functioning lung regions. Surgery often results in effective volume reduction of about 15-30%, which may not be sufficient to cause an appreciable improvement in lung function. Also, conventional lung reduction surgery is traumatic, even when thorascopic procedures are employed.

[0004] Recently, bronchoscopic approaches for reducing effective lung volume have been proposed. See for example, U.S. Patents 6,592,594, 6,679,264,

6,398,775 and 6,610,043; and U.S. Patent Publications 2003/0181922, 2004/0055606, and 2004/0047855. One challenge to achieving effective lung reduction, particularly in emphysematous lungs, is collateral ventilation or collateral pathways.

[0005] According, there is a need for devices, methods and systems for reducing effective lung volume without surgery, and also for reducing lung volume in the presence of collateral pathways. The present invention is directed to meeting these, as well as other, needs.

SUMMARY OF THE INVENTION

[0006] This invention relates to the treatment of a patient's lung, for example, the treatment of chronic obstructive pulmonary disease (COPD) and other conditions that can be treated by decreasing a patient's effective lung volume. In particular methods and devices of the invention relate to treatment for affecting lung volume reduction by delivering a thermal damaging agent to a targeted region of a patient's lung so that the region is essentially non-functional.

[0007] A method of treating a patient's lung includes delivering a thermal damaging agent to a targeted region of the patient's lung to raise the temperature of the tissue in the region sufficiently high to the extent that blood flow and air flow within the targeted region are terminated. Preferably the thermal damaging agent damages at least one of the group consisting of tissue defining at least in part an air sac of the targeted region, tissue of terminal bronchioles in the targeted region and collateral passageways in the targeted region. The method can also include occluding an airway of the lung through which the thermal damaging agent is delivered at a point proximal to where the thermal damaging agent enters the target

region so as to isolate the region and prevent excursions of the thermal damaging agent to areas outside the target region.

[0008] One preferred method of treating a patient's lungs includes delivering a condensable vapor at a temperature above body temperature at atmospheric pressures to lung tissue of the target region, particularly the tissue defining at least in part an air sac within the patient's lung.

[0009] A device for delivering a thermal damaging agent to a targeted region of the patient's lung to raise the temperature of the lung tissue in the targeted region sufficiently high to render the targeted region essentially non-functional wherein neither blood flow or air flow occurs within the region. The device for delivering a thermal damaging agent includes an elongate shaft having a proximal portion, a distal portion, and a thermal damaging agent delivering lumen extending within at least a distal portion of the shaft. The device has at least one discharge port in the distal portion of the elongate shaft in fluid communication with the thermal damaging agent delivering inner lumen. A thermal damaging agent generator is in fluid communication with the thermal damaging agent delivery lumen in the elongate shaft and is configured for generating a thermal damaging agent at a temperature above 40°C to the tissue at the targeted region to render the region essentially non-functional. Preferably the device also includes an occluding member disposed on a distal portion of the shaft to occlude the airway passage proximal to the delivery location of the thermal damaging agent.

[0010] In one embodiment the device includes an elongate shaft having a proximal portion, a distal portion, and a vapor delivering inner lumen extending within at least the distal portion of the shaft. The device has at least one discharge port in the distal portion of the elongate shaft in fluid communication with the vapor delivering inner

lumen configured to deliver condensable vapor to the target region. A condensable vapor generator is provided in fluid communication with the vapor delivering lumen of the elongate shaft for generating a condensable vapor at a temperature above 40°C to thermally damage tissue at the targeted region sufficiently to terminate blood flow and air flow to the targeted region. Preferably the device also includes an occluding member disposed on a distal portion of the shaft. The delivered condensable vapor is generally about 40° to 80° C, and preferably is about 50° to about 60° C. The condensable vapor is delivered to the targeted region for a period of about 5 seconds to about 10 minutes, preferably about 5 seconds to about 10 seconds. Suitable liquids for forming the condensable vapor includes water based fluids and perfluorocarbon

[0011] In addition to the treatment of COPD, other conditions can be treated, for example by applying the methods and devices described to pre-cancerous lesions, cancer tumors, or lung nodules. As will be recognized by those skilled in the art, reducing the total volume of a patient's lung, especially an emphysematous lung, can be an effective treatment for COPD.

BRIEF DESCRIPTION OF THE DRAWINGS

[0012] Figure 1A illustrates a method for treating a patient's lung embodying features of the invention.

[0013] Figure 1B is an enlarged view of an air sac and alveoli within the patient's lung shown in Figure 1A...

[0014] Figure 2 is a longitudinal cross sectional view of the device shown in Figure 2.

[0015] Figures 3A is a transverse cross sectional view of the device shown in Figure 2, taken along lines 3A-3A.

[0016] Figure 3B is a transverse cross sectional view of the device shown in Figure 2, taken along lines 3B-3B.

[0017] Figure 4 is an elevational view, partially in perspective, of a system embodying features of the invention.

[0018] Figure 5A is an elevational view of a vapor generator connected to the device shown in Figure 2.

[0019] Figure 5B is an elevational view of a vapor generator connected to the device shown in Figure 2 which has a cartridge for storing vaporizable fluid.

[0020] Figure 5C is an elevational view of a vapor generator connected to the device shown in Figure 2 which is connected to a hand held operator or pistol grip handle.

DETAILED DESCRIPTION OF THE INVENTION

[0021] Figure 1 illustrates a method for treating a patient's lung 10 embodying features of the invention that includes delivering a condensable vapor 12 to tissue defining an air sac or alveoli 14 within a patient's lung 10 at a temperature above body temperature, preferably about 40°C to about 80°C, preferably about 50°C to about 60°C at atmospheric pressures, so as to damage the tissue of the air sac or alveoli 14, the tissue of terminal bronchioles 16 and tissue of collateral passageways 18. Such tissue damage renders the treated region non-functional in that the blood flow and air flow in the treated region is terminated. The treated region will no longer inflate.

[0022] The method includes delivering the condensable vapor through an airway 20 of the lung to the targeted lung region. Preferably the airway 20 is a bronchial passageway such as segmental bronchi, and most preferably a sub segmental bronchi 20.

[0023] The condensable vapor 12 serves to rapidly heat the targeted lung region as the vapor 12 is delivered and induces tissue collapse, shrinkage, neointima hyperplasia, necrosis and fibrosis (collectively referred to herein as "bioeffects") of the targeted lung region. Such bioeffects render the target lung region non-functioning.

[0024] The method may also include applying a vacuum to the targeted region after delivery of the condensable vapor to further supplement tissue contraction and collapse caused by introduction of the condensable vapor 12. The vacuum generated in the targeted region is about 1 to about 50 mm Hg, preferably about 10 to about 30 mm Hg to effectively collapse the targeted region. The vacuum may also facilitate aspiration of any residual vapor or liquid.

[0025] In general the vapor is applied into the targeted region through an airway for anywhere from 5 seconds to 10 minutes or longer. Preferably the condensable vapor is delivered for a short period of time, about 5 seconds to 10 seconds. Because tissue heating and the resulting damage is rapid using energetic vapor, short vapor application times are preferred. In longer procedures, less vapor may be used to cause gradual tissue bioeffects or to treat larger regions or volumes of tissue. Separate procedures may be utilized for separate regions to be treated.

[0026] The condensable vapor 12 maybe generated from a liquid, for example, sterile water or other fluids such as perfluorocarbons, having relatively high liquid-gas phase-change temperatures, i.e. boiling points, preferably temperatures well above body temperature. In addition, preferably the condensable vapor 12 is at a temperature sufficient to increase the temperature of the surrounding lung parenchyma to cause damage, for example, above at least 40°C.

[0027] In one method of the invention the condensable vapor 12 additionally includes a detectable substance, such as a dye, preferably a biocompatible dye, to detect movement of the condensable vapor 12 and the affected lung regions. Alternatively or in conjunction with the visually detectable substance, diagnostic ultrasound, endoscopic and other conventional visualization techniques are used to monitor the vapor treatment and resulting tissue effects during and after treatment.

[0028] In another method embodying features of the invention, the condensable vapor 12 is delivered with microparticulates. Suitable microparticulates include talc, calcium carbonate, antibiotics such as tetracycline and other penicillin derivatives, or other particulate substances which induce fibrosis or cause necrosis of the lung tissue.

[0029] In another method embodying features of the invention the condensable vapor 12 includes a treatment agent such as an anesthetic or painkillers to alleviate patient discomfort and pain during the treatment. A painkiller, such as lidocaine in powder or liquid form, preferably is used or mixed with a condensable vapor 12. Alternatively, pain killers may be delivered to the entire lung, or just to the targeted lung region. Patient preparation with pain medication before, during, and after the procedure is preferred in order to allow treatment using the present invention without the need for general anesthesia.

[0030] In another method embodying features of the invention helium or carbon dioxide is delivered in addition to the vapor 12 to lower the temperature of the vapor 12.

[0031] A method of the invention includes occluding the airway of a lung proximal to the area where the condensable vapor 12 is delivered. In some embodiments, to prevent condensable vapor from entering and damaging adjacent airways and lung

regions, the adjacent airways are filled with a fluid, such as saline. Airways leading to untargeted lung regions may be obstructed to prevent vapor flow therein.

[0032] In one method embodying features of the invention high intensity focused ultrasound (HIFU) energy is delivered to damage lung tissue such as the tissue of an air sac or alveoli in the lung. Preferably suitable ultrasound transducers that are capable of delivering high intensity focused ultrasound (HIFU), generally between about 100-10,000 W/cm² at a focal spot.

[0033] The HIFU energy is delivered in amounts sufficient to cause contraction of lung tissue. Because HIFU can be tightly controlled, the ultrasound energy can be specifically targeted to the epithelium, smooth muscle layer, or collagen layer. Delivery of the HIFU energy can also serve to initiate a healing response (including neointima hyperplasia) which further serves to occlude the passageway. The method can include a wave guide to direct the HIFU sound waves to the intended treatment site. Additionally a vacuum may be applied prior the HIFU to draw down the airway or air sacs. Alternatively the vacuum may be applied after delivery of the HIFU energy as in the previously discussed embodiment to further supplement tissue contraction and collapse of the terminal bronchioles, air sacs and collateral passageways caused by introduction of the ultrasound energy.

[0034] In another embodiment, an ultrasound absorptive material, such as a liquid or gel, can be eluted into the airway of the lung. The absorptive material is heated by the HIFU energy in order to thermally damage the surrounding tissue, resulting in contraction of the airway and or neointima hyperplasia, which will occlude the airway and or damage the air sacs of the lung.

[0035] In an alternative embodiment, RF energy can be delivered to a desired location within a patient's lung to damage lung tissue but this usually requires a conductive fluid in contact with the lung tissue for effective ablation.

[0036] Figure 2 depicts a system 22 embodying features of the invention including an elongate shaft 24 having a distal portion 26 and a proximal portion 28. Figure 2 is a longitudinal cross sectional view of the elongate shaft 24 and Figures 3A and 3B show transverse cross sectional views of the elongate shaft along the lines 3A-3A and lines 3B-3B shown in Figure 2. The elongated shaft 24 has at least one discharge port 30 in the distal portion 26 of the shaft configured to discharge condensable vapor 12 and a vapor delivering lumen 32 disposed within the elongate shaft 24 in fluid communication with the discharge port 30. A vapor generator 34 is connected to the lumen 32 of the elongate shaft.

[0037] The elongate shaft 24 also contains a vacuum lumen 36 which is configured to be connected to a vacuum source for application of a vacuum through vacuum port 38 in the distal portion 26 of the elongate shaft.

[0038] The elongated shaft 24 is also provided with an inflation lumen 40 which leads to the inflation port 42. Port 42 opens to the interior 44 of the inflatable balloon 46 which is secured to the distal portion 26 of the shaft. The inflation device 48 may be a conventional syringe. The occluding member 46 is preferably expandable, compliant, and is configured to prevent vapor flow proximal to the location of the member. Suitable balloon materials include silicone or latex. The exterior of the working surface of the inflatable balloon 46 is preferably provided with a knurled or roughened surface to better engage the airway walls and prevent recoil when the condensable vapor is delivered to the target location.

[0039] A venting system may be included with the device to ensure that high pressure does not exceed suitable limits. The venting system includes a venting lumen 50 in the shaft 24 which is in fluid communication with the port 52 in the distal end of the shaft 24. The venting mechanism can be a pressure actuated relief valve 54.

[0040] The device 22 also includes a temperature sensor 56, for example a thermocouple, located on the distal portion 26 of the elongate shaft 24 to monitor the surrounding temperature. When the temperature is too high, the lung region is brought back to normal temperatures with a lavage or washout procedure to facilitate removal of residual vapor.

[0041] The device 22 preferably includes a pressure sensor 58 on the distal portion 26 of the elongate shaft 24 to detect pressure within the targeted lung region. The pressure sensor 58 communicates with a pressure gauge 60 on the proximal portion 28 of the elongate shaft 24. The pressure sensing system may be tied in with the venting system to ensure that preset pressure limits are not exceeded during vapor delivery. Over inflation of the target region could lead to air leaks and tears in the lung pleura.

[0042] A suitable flow meter (not shown) may be included to monitor vapor flow to the targeted region of the patient's lung.

[0043] As shown in Figure 4 the elongate shaft 24 is configured to be delivered through the working channel (not shown) of an endoscope 62, preferably a bronchoscope. The working channel of the endoscope 62 is preferably between about 1.5 mm and 3.5 mm. The endoscope 62 is connected to an endoscope controller 64 and an endoscope monitor 66. Preferably, the distal portion 26 of the elongate shaft 24 is flexible to facilitate advancement of the elongate shaft in the

working channel of the endoscope 56, while the proximal portion 28 is sufficiently rigid for good pushability of the shaft through and out of a distal opening of the endoscope. The distal portion 26 of the shaft 24 is about 1-6 French, the occluding balloon when inflated is larger than the working channel of the endoscope and is typically about 8 French. A suitable endoscope is the Olympus LF-TP bronchoscope.

[0044] Alternatively or in addition to the use of the occluding member 46, airways adjacent the delivery airway can be obstructed, for example, with a fluid such as saline. The fluid in the adjacent airways prevents condensable vapor 12 from entering into other lung regions which are not targeted for treatment and prevents damage of the adjacent regions.

[0045] Preferably the vapor generator 34, as shown in Figure 5A, is external to the elongate shaft 24 and stores the liquid supply. The vapor generator 34 has an outer housing 72 which houses internal structures including a liquid chamber 74 and an inner vapor conduit 76. Liquid may be loaded directly into the liquid chamber. The inner vapor conduit 76 extends from the liquid chamber 74 of the vapor generator 34 to the proximal portion 26 of the first lumen 32 and receives the condensable vapor 12 from the liquid chamber 74 via an inlet port 78. The vapor generator 34 couples to the elongate shaft 24 via a luer fitting or similar mechanism. The liquid chamber 74 has heating elements such as resistive heating elements, or a RF heater or the like for vaporizing liquid inside the liquid chamber to a condensable vapor. When the liquid is vaporized, the vapor travels from the liquid chamber 74 through the inner vapor conduit 76 and exits into the proximal portion of the vapor lumen 32 of the elongate shaft 24 of the device.

[0046] Alternatively, as shown in Figure 5B the vapor generator includes a cartridge compartment 80 which receives a cartridge 82 in fluid communication with the lumen 32 and containing a predetermined amount of liquid for vaporizing. The cartridge 82 is configured to preferably snap-fit into the compartment 80. When the vapor generator 34 is activated the fluid in the cartridge 82 is heated to a vapor. The condensable vapor 12 is then delivered to the proximal end of the first lumen 32. A predetermined volume or amount of vapor pressure to be delivered to a patient's lung 10 can be determined or calculated based on diagnostic evaluations or parameters of the patient before the treatment procedure, such as forced expiratory volume (FEV) or other lung function and capacity indicators.

[0047] In one embodiment, the vapor generator 34, as shown in Figure 5C has an inner vapor conduit 76 which extends into a generator tube 84. The generator tube 84 connects to a pistol grip handle 86 which is configured to couple to the proximal portion 26 of the elongate shaft. The pistol grip handle 86 can be used to activate heating of the vapor 12 within the liquid chamber 74 of the vapor generator 34. The condensable vapor travels from the vapor generator 34 to the pistol grip 86 and into the elongate shaft 24.

[0048] Alternatively, the vapor generator 34 can be disposed within the elongate shaft 24. The heating elements, for example an RF electrode or emitter such as a helical coil, may be embedded within the wall of the shaft, surrounding the lumen 32. The heater may be used as an alternative to the vapor generator 34 or to augment or further control the temperature of the vapor leaving the discharge port 30 from lumen 32.

[0049] Preferably, the elongate shaft 24 of the device 22 is heat insulated to avoid overheating of the elongate shaft 24 inside the endoscope 62. In one embodiment

the elongate shaft 24 contains a liquid lumen (not shown) and a cooling fluid is delivered within this lumen to prevent overheating.

[0050] The condensable vapor 12 is a substance which is capable of rapidly heating a region of the lung to render the target region non-functioning where there is little or no blood flow or air flow within the region. Suitable condensable vapors 12 are selected from the group consisting of condensable vapors from aqueous based fluids, for example, sterile water, saline, contrast fluid, and other fluids such as perfluorocarbons, liquid antibiotics, and other liquids having high liquid-gas phase-change temperatures, i.e. boiling point, preferably above body temperature. In addition preferably the condensable vapor 12 is at a temperature sufficient to increase the temperature of the tissue at the target site to cause tissue damage.

[0051] In another embodiment of the invention the condensable vapor 12 includes a detectable substance, such as a dye or a biocompatible dye, to allow the physician to visually track progress of treatment and which lung regions have been treated. Alternatively or in conjunction with the visually detectable material, diagnostic ultrasound, endoscopic and other conventional visualization techniques are used to monitor the condensable vapor treatment and resulting tissue effects during and after treatment.

[0052] In yet another embodiment the condensable vapor 12 comprises a treatment agent such as a pain-numbing substance or painkillers to alleviate patient discomfort and pain during the treatment. A painkiller, such as lidocaine in aqueous powder or liquid form, preferably is used or mixed with a condensable vapor 12. Alternatively pain killers are delivered to the entire lung, or the targeted lung region. Preferably patient preparation with pain medication before, during, and after the procedure is preferred in order to allow treatment using the present invention without

the need for general anesthesia. The device can include a drug delivery lumen in fluid communication with a drug delivery port in the distal portion of the elongate shaft. Painkillers or other drugs can be delivered to the desired area through the optional drug delivery lumen.

[0053] In yet another embodiment the elongate shaft 24 of device 22 has a helium or carbon dioxide delivery lumen (not shown) for delivering helium or carbon dioxide in addition to the vapor 12 to lower the temperature of the condensable vapor 12.

[0054] While particular forms of the invention have been illustrated and described herein, it will be apparent that various modifications and improvements can be made to the invention. Moreover, individual features of embodiments of the invention may be shown in some drawings and not in others, but those skilled in the art will recognize that individual features of one embodiment of the invention can be combined with any or all the features of another embodiment. Accordingly, it is not intended that the invention be limited to the specific embodiments illustrated. It is therefore intended that this invention be defined by the scope of the appended claims as broadly as the prior art will permit.

[0055] Terms such as "element", "member", "device", "section", "portion", "component", "means", "steps" and words of similar import when used herein shall not be construed as invoking the provisions of 35 U.S.C §112(6) unless the following claims expressly use the terms "means" or "step" followed by a particular function without reference to a specific structure or action. All patents and all patent applications referred to above are hereby incorporated by reference in their entirety.

WHAT IS CLAIMED IS:

1. A system for treating a patient's lung comprising means for heating a liquid to form a condensable vapor and means for delivering the condensable agent to a targeted region of the patient's lung to raise the temperature of tissue in the targeted region sufficiently high to render the targeted region non-functional.

2. The system of claim 1 wherein tissue damage within the targeted region causes blood flow and air flow within the targeted region to be terminated.

3. The system of claim 1 wherein the condensable vapor damages at least one of the group consisting of tissue defining at least in part an air sac of the patient's targeted region, tissue of terminal bronchioles in the targeted region and collateral passageways in the targeted region.

4. The system of claim 1 wherein an airway of the patient's lung through which the thermal damaging agent is delivered is occluded proximal to a point where the thermal damaging agent enters the target region.

5. The system of claim 1 wherein the condensable vapor is at a temperature above 60° C.

6. The system of claim 1 wherein the condensable vapor is at a temperature above 80° C at atmospheric pressure.

7. The system of claim 1 wherein the condensable vapor is at a temperature above 100° C.

8. The system of claim 1 wherein condensable vapor is delivered to the target region for about 5 seconds to 10 minutes.

9. The system of claim 1 wherein the condensable vapor is delivered to the target region for about 5 seconds to about 10 seconds.

10. The system of claim 1 wherein the condensable vapor is a water vapor.
11. The system of claim 1 wherein the condensable vapor is a perfluorocarbon vapor.
12. The system of claim 1 wherein the condensable vapor is generated from a liquid having a liquid-gas-phase change temperature which is above 40° C at atmospheric pressure.
13. The system of claim 1 wherein the condensable vapor is generated from a liquid having a liquid-gas phase change temperature above 50°C at atmospheric pressure.
14. The system of claim 1 wherein the condensable vapor is generated from a liquid having a liquid-gas phase change temperature over 100°C at atmospheric pressure.
15. The system of claim 1 wherein the condensable vapor is delivered with a detectable substance.
16. The system of claim 15 wherein the detectable substance is a dye.
17. The system of claim 15 wherein the detectable substance is biocompatible.
18. The system of claim 1 wherein the condensable vapor is delivered with microparticulates.
19. The system of claim 18 wherein the microparticulates are selected from the group consisting of talc, calcium carbonate, or antibiotics.
20. The system of claim 19 wherein the microparticulates induce fibrosis or necrosis of the lung tissue.
21. The system of claim 1 wherein the condensable vapor rapidly heats tissue at the target site.

22. The system of claim 1 wherein the condensable vapor is advanced to the target site through a bronchial passageway of the lung.

23. The system of claim 22 wherein the bronchial passageway is a sub-segmental bronchi of the lung.

24. The system of claim 1 wherein a vacuum is generated within the target site to facilitate collapse of tissue structures thereof.

25. The system of claim 24 wherein the tissue structures collapsed are at least one of the group consisting of an air sac of the patient's targeted region, terminal bronchioles in the targeted region and collateral passageways in the targeted region.

26. The system of claim 24 wherein the applied vacuum at the target site is about 50 to about 60 mm Hg.

27. The system of claim 24 wherein the applied vacuum at the target site is about 40 to about 50 mm Hg.

28. A device for delivering a thermal damaging agent to a targeted region of the patient's lung to raise the temperature of tissue in the targeted region sufficiently high to render the targeted region non-functional, comprising:

- a. an elongate shaft having a proximal portion, a distal portion and a thermal damaging agent delivering inner lumen extending within at least the distal portion of the shaft;
- b. at least one discharge port in the distal portion of the elongate shaft in fluid communication with the thermal damaging agent delivering inner lumen configured to deliver the thermal damaging agent;
- c. a thermal damaging agent generator in fluid communication with the first lumen of the elongate shaft for generating a thermal damaging

agent at a temperature above 60° C to thermally damage tissue at the targeted region.

29. The device of claim 28 wherein an occluding member is disposed on the distal shaft portion.

30. The device of claim 29 wherein the occluding member is expandable.

31. The device of claim 30 wherein the expandable occluding member is inflatable.

32. The device of claim 31 wherein the elongate shaft includes an inflation lumen, an inflation port which is in fluid communication with the inflation lumen and an interior of the inflatable occluding member.

33. The device of claim 32 wherein the inflatable occluding member is a balloon.

34. A system of treating a patient's lung comprising means to deliver a condensable vapor at a temperature above body temperature at atmospheric pressures to tissue defining at least in part an air sac within the patient's lung.

35. The system of claim 34 wherein the condensable vapor also damages at least one of the groups consisting of tissue of terminal bronchioles in the targeted region and tissue defining collateral passageways in the targeted region.

36. The system of claim 34 wherein an airway of the patient's lung through which the condensable vapor is delivered is occluded proximal to a point where the condensable vapor enters the target region.

37. The system of claim 34 wherein the condensable vapor is at a temperature above 60°C.

38. The system of claim 34 wherein the condensable vapor is at a temperature above about 80° C.

39. The system of claim 34 wherein the condensable vapor is at a temperature above about 100° C.
40. The system of claim 34 wherein condensable vapor is delivered to the target region for about 5 seconds to 10 minutes.
41. The system of claim 34 wherein condensable vapor is delivered to the target region for about 5 seconds to about 10 seconds.
42. The system of claim 34 wherein the condensable vapor is water vapor.
43. The system of claim 34 wherein the condensable vapor is a perfluorocarbon vapor.
44. The system of claim 34 wherein the condensable vapor is generated from a liquid having a liquid-gas-phase change temperature above 40° C at atmospheric pressure.
45. The system of claim 34 wherein the condensable vapor is generated from a liquid having a liquid-gas phase change temperature above 50°C at atmospheric pressure.
46. The system of claim 34 wherein the condensable vapor is generated from a liquid having a liquid-gas phase change temperature over 100°C at atmospheric pressure.
47. The system of claim 34 wherein the condensable vapor is delivered with a detectable substance.
48. The system of claim 47 wherein the detectable substance is a dye.
49. The system of claim 47 wherein the detectable substance is biocompatible.
50. The system of claim 34 wherein the condensable vapor is delivered with microparticulates.

51. The system of claim 50 wherein the microparticulates are selected from the group consisting of talc, calcium carbonate, or antibiotics.

52. The system of claim 50 wherein the microparticulates induce fibrosis or necrosis of the lung tissue.

53. The system of claim 34 wherein the condensable vapor rapidly heats tissue at the target site.

54. The system of claim 34 wherein the condensable vapor is advanced to the target site through a bronchial passageway of the lung.

55. The system of claim 54 wherein the bronchial passageway is a segmental or a sub-segmental bronchi of the lung.

56. The system of claim 34 wherein a vacuum is generated within the target site to collapse tissue structures thereof.

57. The system of claim 56 wherein the tissue structures collapsed are at least one of the group consisting of tissue of terminal bronchioles in the targeted region and tissue of collateral passageways in the targeted region.

58. The system of claim 56 wherein the applied vacuum at the target site is about 50 to about 60 mm Hg.

59. The system of claim 56 wherein the applied vacuum at the target site is about 40 to about 50 mmHg.

60. The system of claim 34 wherein an airway of the lung through which the condensable vapor is delivered is occluded proximal to a point where the condensable vapor enters the target site.

61. A device for delivering a condensable vapor to a targeted region of a patient's lung to raise the temperature of tissue in the targeted region sufficiently high to render the targeted region non-functional, comprising:

- a. an elongate shaft having a proximal portion, a distal portion and a vapor delivering inner lumen extending within at least the distal portion of the shaft;
- b. at least one discharge port in the distal portion of the elongate shaft in fluid communication with the vapor delivering inner lumen configured to deliver the condensable vapor; and
- c. a condensable vapor generator in fluid communication with the vapor delivering lumen of the elongate shaft for generating a condensable vapor at a temperature above 60° C to thermally damage tissue at the target site sufficiently to terminate blood flow and air flow to the targeted region.

62. The device of claim 61 wherein an occluding member is disposed on the distal shaft portion.

63. The device of claim 62 wherein the occluding member is expandable.

64. The device of claim 63 wherein the expandable occluding member is inflatable.

65. The device of claim 64 wherein the elongate shaft includes an inflation lumen, an inflation port which is in fluid communication with the inflation lumen and an interior of the inflatable occluding member.

66. The device of claim 64 wherein the inflatable member is a balloon.

67. The device of claim 61 wherein the shaft has a second lumen disposed which has a proximal end configured to be connected to a vacuum source and which has a vacuum port on the distal end of the elongate shaft in fluid communication with the second lumen.

68. The device of claim 61 wherein the elongate shaft is configured to be delivered through a working channel of an endoscope.

69. The device of claim 68 wherein the endoscope has a working channel with a diameter of about 1.5 mm to about 3.5 mm.

70. The device of claim 61 wherein at least a portion of the elongate shaft is heat insulated.

71. The device of claim 61 wherein the elongate shaft contains a coolant lumen configured to contain a cooling fluid.

72. The device of claim 61 wherein a pressure sensor is mounted on the distal portion of the elongate shaft.

73. The device of claim 72 wherein a pressure gauge is provided on the proximal portion of the elongate shaft to display the pressure sensed by the pressure sensor.

74. The device of claim 73 wherein the pressure gauge is connected to a venting system having a venting port in the distal portion of the elongate shaft which is in fluid communication with a fourth lumen.

75. The device of claim 74 wherein the venting system and pressure gauge are configured to operate a feedback loop.

76. The device of claim 75 wherein the pressure gauge is connected to a pressure controller.

77. The device of claim 61 wherein the elongate shaft has a flow sensor for measuring vapor flow through the elongated shaft.

78. The device of claim 77 wherein the flow meter is connected to a pressure controller.

79. The device of claim 61 wherein the elongate shaft has a temperature sensor located on the distal end of the elongate shaft.

80. The device of claim 79 wherein the temperature sensor is a thermocouple.

81. The device of claim 61 wherein the vapor generator has a supply of liquid which forms condensable vapor.

82. The device of claim 66 wherein the supply of liquid is located in the vapor generator.

83. The device of claim 62 wherein the vapor generator is disposed within the occluding member.

84. The device of claim 61 herein the vapor generator is external to the elongate shaft.

85. The device of claim 69 wherein the vapor generator has an outer housing which houses a liquid receiving chamber.

86. The device of claim 85 wherein an inner vapor conduit extends from the liquid chamber to the proximal end of the elongate shaft.

87. The device of claim 86 wherein the inner vapor conduit couples to the elongate shaft with a luer fitting.

88. The device of claim 87 wherein the inner vapor conduit receives the condensable vapor from the liquid chamber via an inlet port.

89. The device of claim 85 wherein heating elements are provided in the liquid receiving chamber.

90. The device of claim 89 wherein the heating elements in the liquid chamber are resistive heating elements.

91. The device of claim 61 wherein the vapor generator has a cartridge compartment which receives a cartridge containing a liquid within a liquid chamber thereof.

92. The device of claim 91 wherein the cartridge is configured to snap into place within the cartridge compartment.

93. The device of claim 91 wherein an inner vapor conduit extends into a generator tube which connects the liquid chamber of the cartridge to a pistol grip handle.

94. The device of claim 93 wherein the pistol grip handle is configured to attach to the proximal end of the elongate shaft.

95. A system for treating a patient's lung comprising means for generating a thermal damaging agent and means for delivering the thermal damaging agent to a targeted region of the patient's lung to raise the temperature of tissue in the targeted region sufficiently high to render the targeted region non-functional.

96. The system of claim 95 wherein thermal damaging agent is configured to damage tissue within the targeted region so as to cause blood flow and air flow within the targeted region to be terminated.

97. The system of claim 95 wherein the tissue damaging agent is configured to damage at least one of the group consisting of tissue defining at least in part an air sac of the patient's targeted region, tissue of terminal bronchioles in the targeted region and collateral passageways in the targeted region.

98. The system of claim 95 wherein the tissue damaging agent is a condensable vapor at a temperature greater than body temperature.

99. The system of claim 95 wherein the tissue damaging agent is high intensity focused ultrasound.

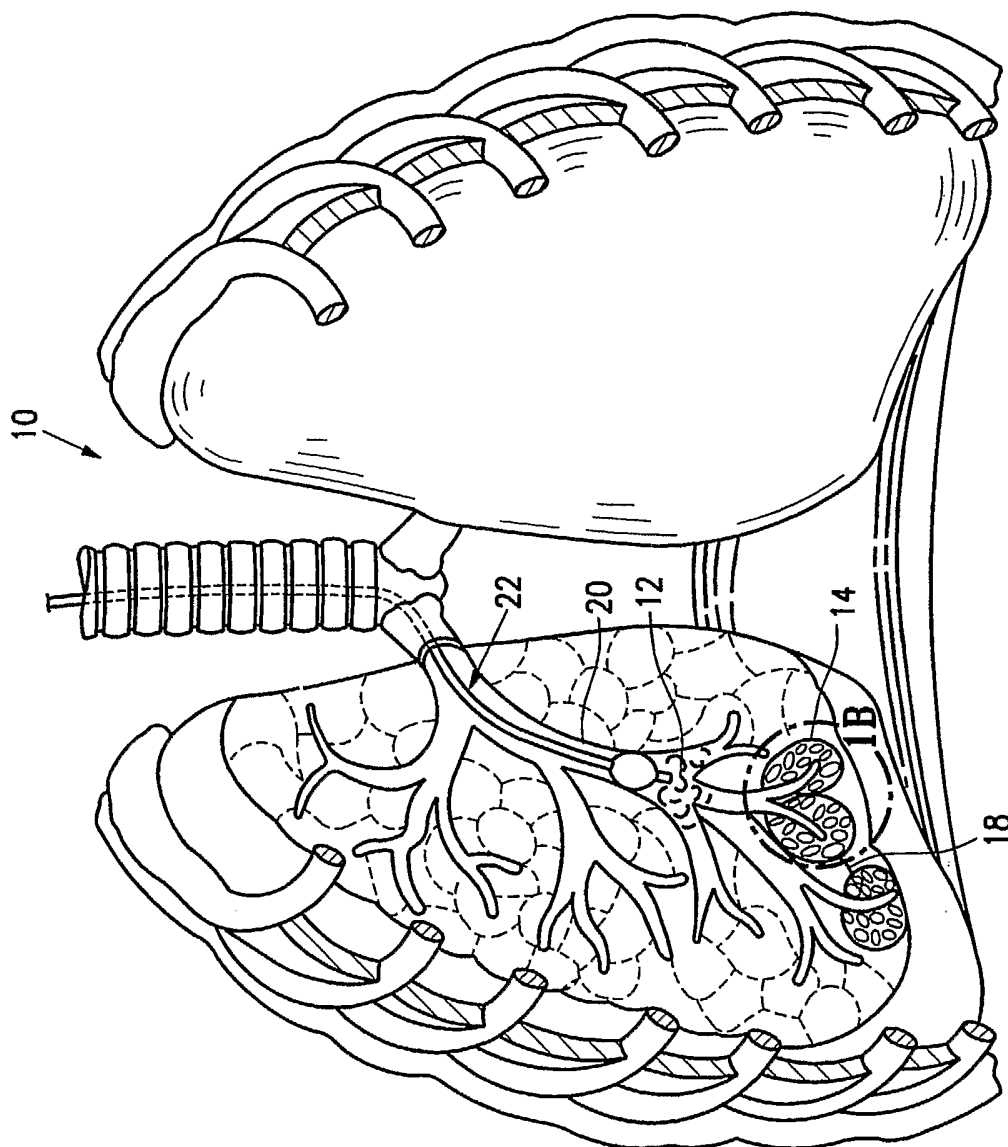

FIG. 1A

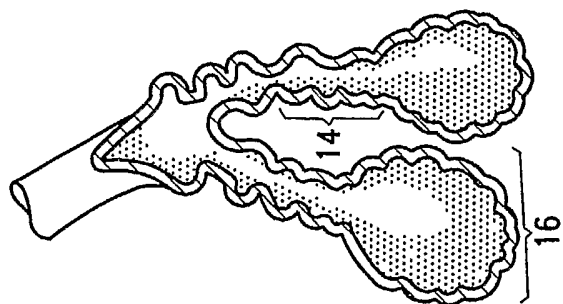
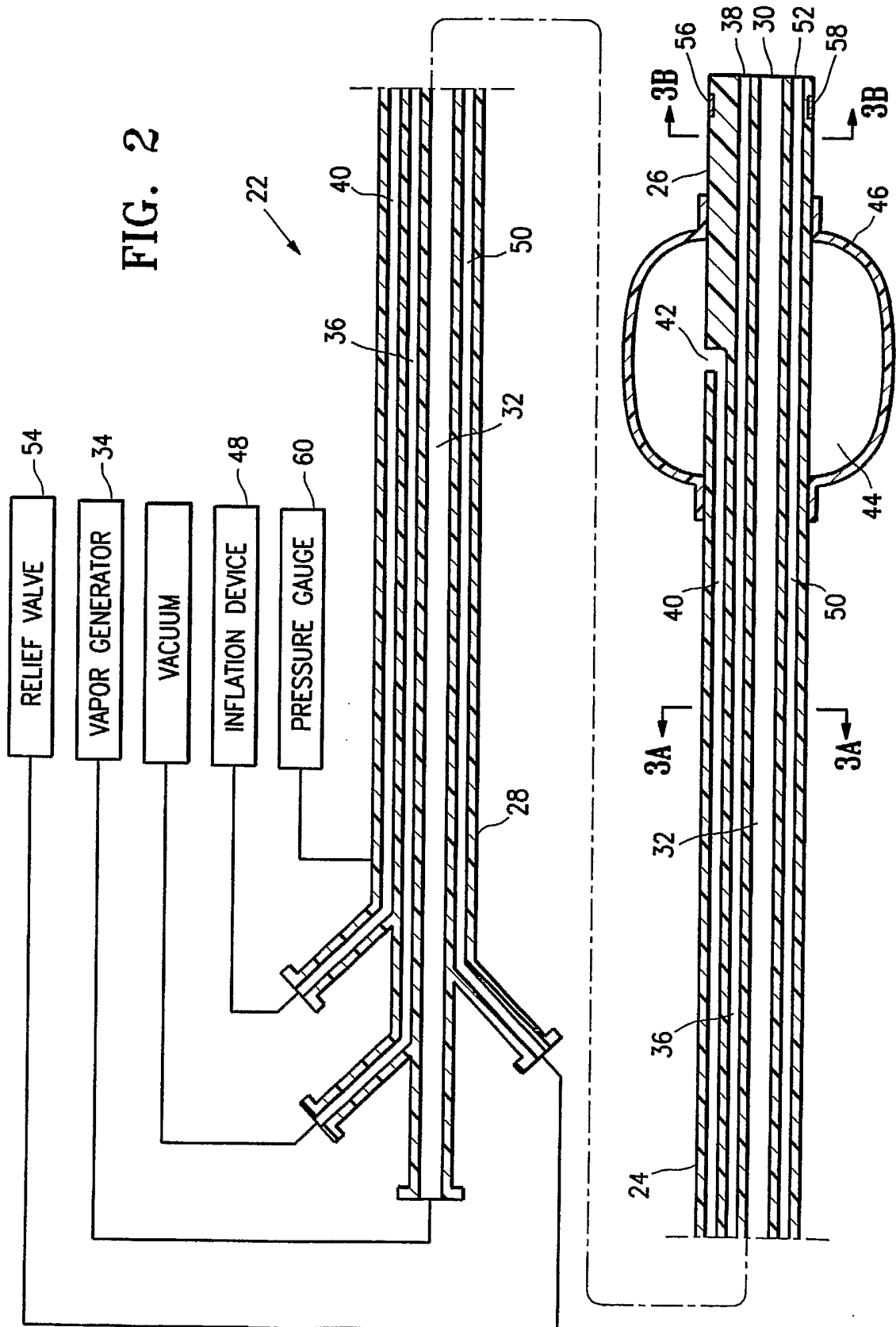

FIG. 1B



3/5

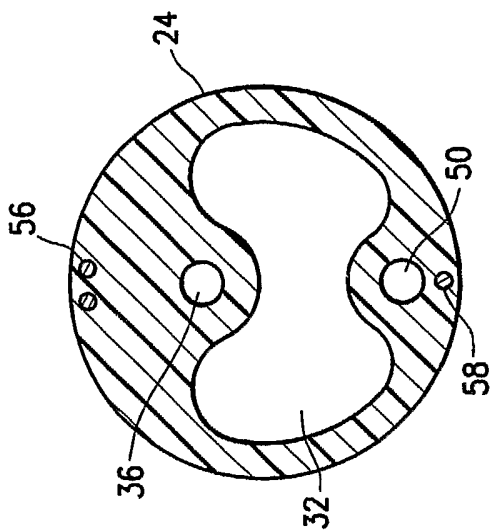

FIG. 3B

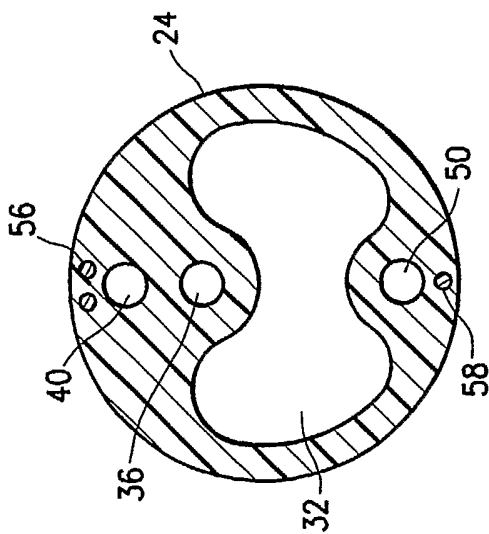

FIG. 3A

4/5

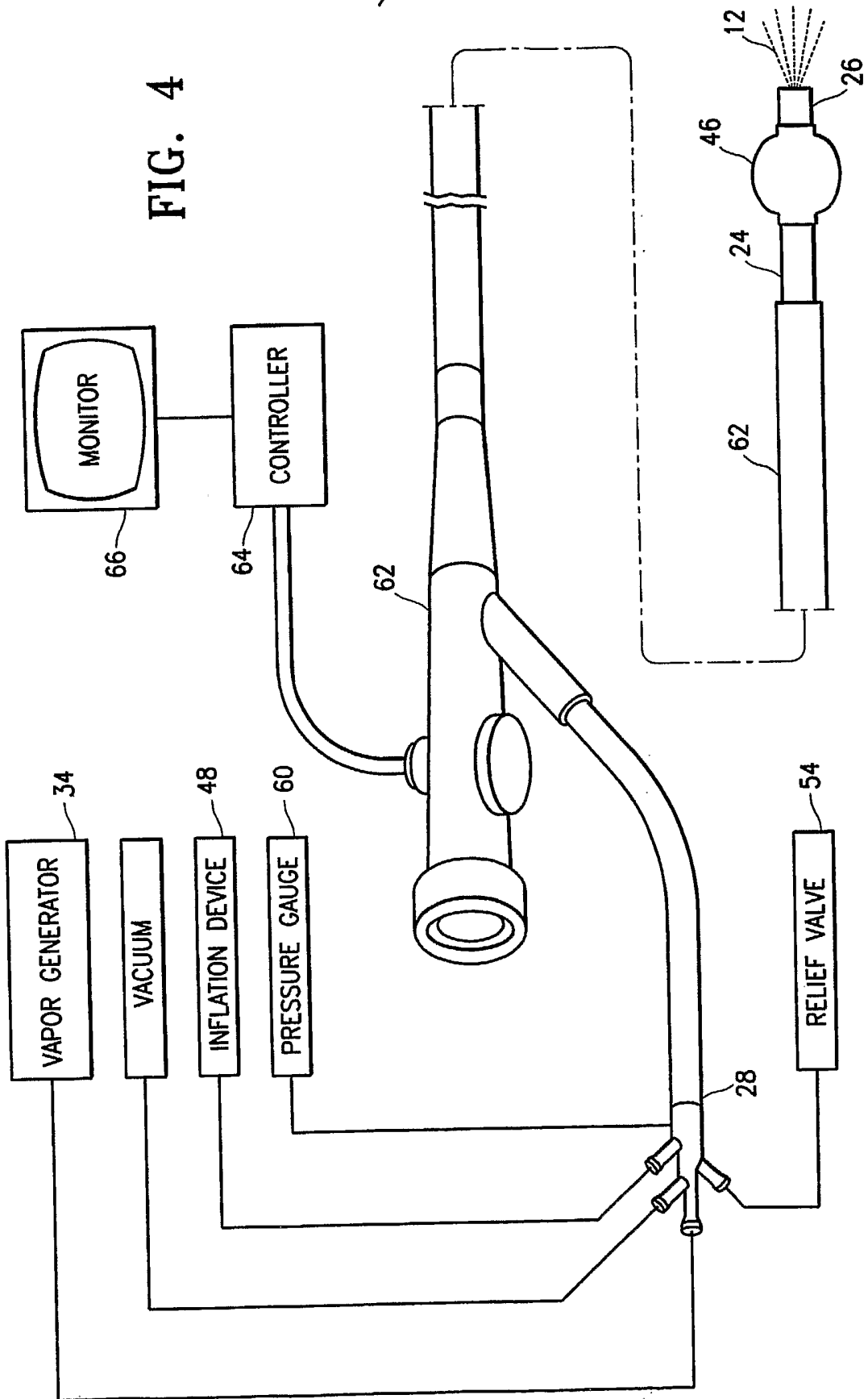

FIG. 4

5/5

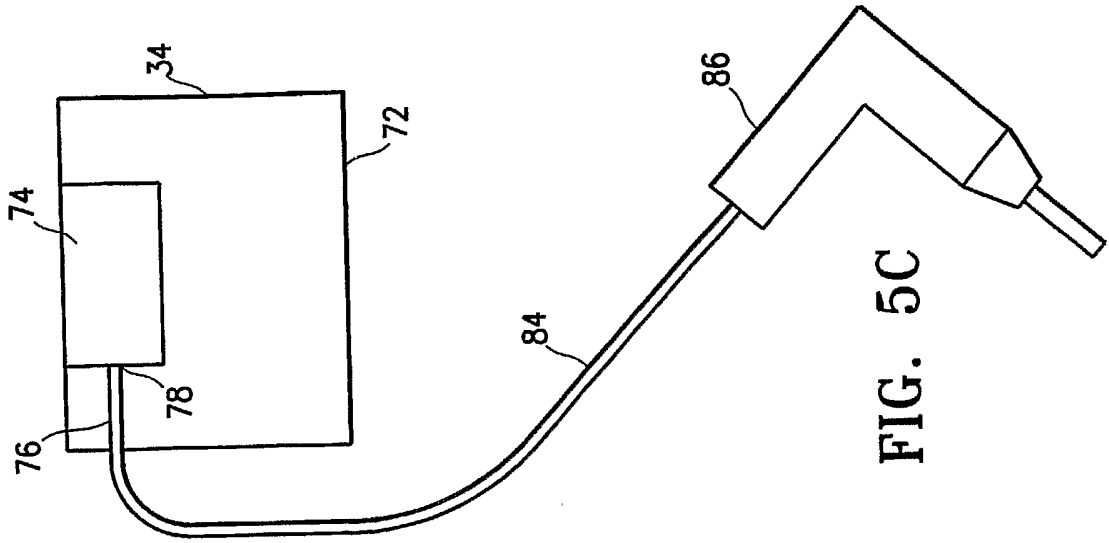

FIG. 5C

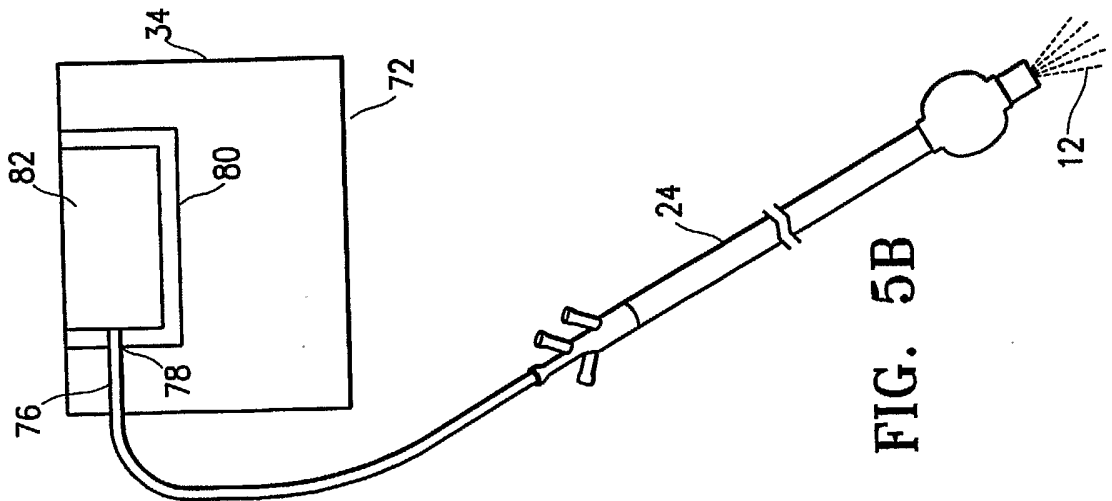

FIG. 5B

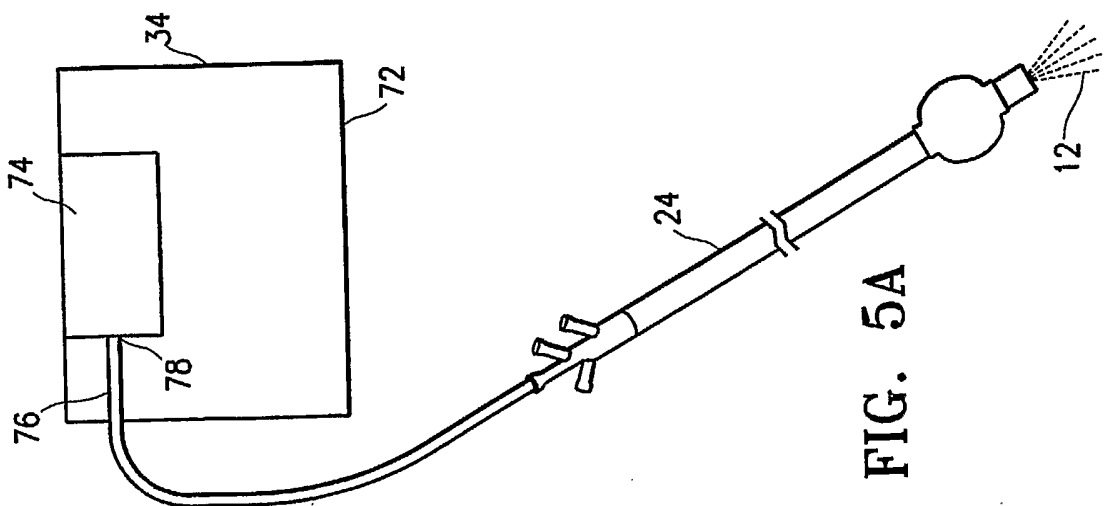

FIG. 5A

INTERNATIONAL SEARCH REPORT

International application No
US2005/041651

A. CLASSIFICATION OF SUBJECT MATTER A61B18/04		
According to International Patent Classification (IPC) or to both national classification and IPC		
B. FIELDS SEARCHED Minimum documentation searched (classification system followed by classification symbols) A61B A61M		
Documentation searched other than minimum documentation to the extent that such documents are included in the fields searched		
Electronic data base consulted during the international search (name of data base and, where practical, search terms used) EPO-Internal		
C. DOCUMENTS CONSIDERED TO BE RELEVANT		
Category*	Citation of document, with indication, where appropriate, of the relevant passages	Relevant to claim No.
X	WO 02/069821 A (THERMEMED CORP) 12 September 2002 (2002-09-12) the whole document	1-10, 12-15, 21-42, 44-47, 53-82, 84-98
<input checked="" type="checkbox"/> Further documents are listed in the continuation of Box C.		
<input checked="" type="checkbox"/> See patent family annex.		
* Special categories of cited documents :		
A document defining the general state of the art which is not considered to be of particular relevance *E* earlier document but published on or after the International filing date *L* document which may throw doubts on priority claim(s) or which is cited to establish the publication date of another citation or other special reason (as specified) *O* document referring to an oral disclosure, use, exhibition or other means *P* document published prior to the international filing date but later than the priority date claimed	*T* later document published after the international filing date or priority date and not in conflict with the application but cited to understand the principle or theory underlying the invention *X* document of particular relevance; the claimed invention cannot be considered novel or cannot be considered to involve an inventive step when the document is taken alone *Y* document of particular relevance; the claimed invention cannot be considered to involve an inventive step when the document is combined with one or more other such documents, such combination being obvious to a person skilled in the art. *&* document member of the same patent family	
Date of the actual completion of the international search	Date of mailing of the international search report	
8 March 2006	21/03/2006	
Name and mailing address of the ISA/ European Patent Office, P.B. 5818 Patentlaan 2 NL - 2280 HV Rijswijk Tel. (+31-70) 340-2640, Tx. 31 651 epo nl, Fax: (+31-70) 340-3016	Authorized officer Borowski, A	

INTERNATIONAL SEARCH REPORT

International application No

US2005/041651

C(Continuation). DOCUMENTS CONSIDERED TO BE RELEVANT		
Category*	Citation of document, with indication, where appropriate, of the relevant passages	Relevant to claim No.
X	WO 00/11927 A (MAMAEV, GENNADY VIKTOROVICH) 9 March 2000 (2000-03-09) the whole document	1-3, 5-10, 12-15, 21-23, 28, 34, 35, 37-42, 44-47, 53-57, 61, 70, 81, 82, 95-98
X	US 6 409 723 B1 (EDWARDS STUART D) 25 June 2002 (2002-06-25) column 3, line 30 - column 4, line 8 column 6, line 43 - line 65	95-97, 99
X	US 5 620 440 A (HECKELE ET AL) 15 April 1997 (1997-04-15) the whole document	95-97
X	MORICE R C; ECE T; ECE F; KEUS L: "Endobronchial argon plasma coagulation for treatment of hemoptysis and neoplastic airway obstruction." CHEST, vol. 119, no. 3, March 2001 (2001-03), pages 781-787, XP002371015 United States the whole document	95-97

INTERNATIONAL SEARCH REPORT

Information on patent family members

International application No

.../US2005/041651

Patent document cited in search report	Publication date	Patent family member(s)	Publication date
WO 02069821	A	12-09-2002 NONE	
WO 0011927	A	09-03-2000 RU 2193871 C2	10-12-2002
US 6409723	B1	25-06-2002 AU 4058200 A WO 0059393 A1 US 6425877 B1	23-10-2000 12-10-2000 30-07-2002
US 5620440	A	15-04-1997 DE 4338866 C1 FR 2712171 A1 GB 2283681 A	14-06-1995 19-05-1995 17-05-1995