

(No Model.)

W. S. RUSSELL.
FOUNTAIN INK WELL.

No. 523,010.

Patented July 17, 1894.

Fig. 1.

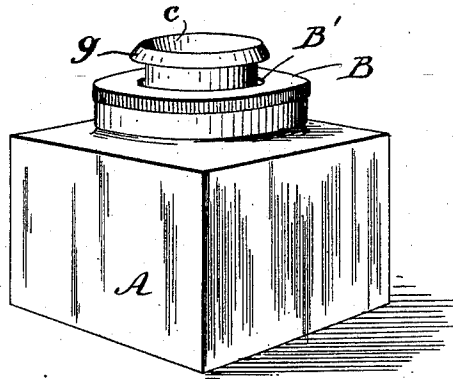

Fig. 3.

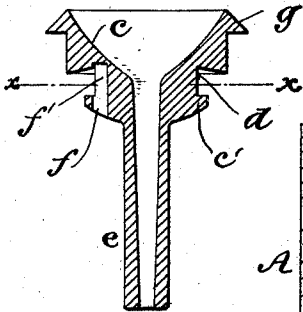

Fig. 2.

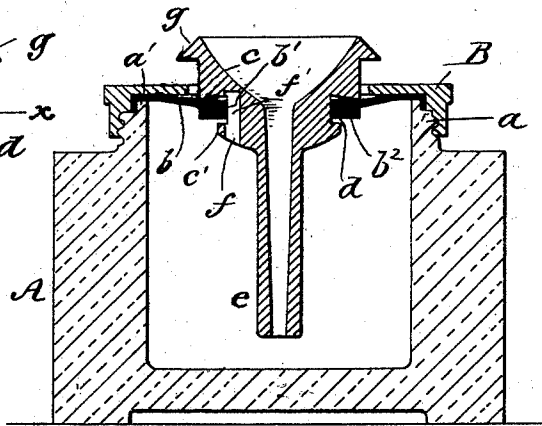
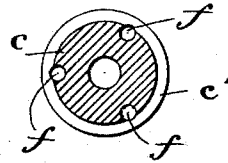

Fig. 4.



WITNESSES:
John H. Deemer
Perce P. Griffiths

INVENTOR
Winfield S. Russell
BY *Edgar Tate & Co*

ATTORNEY

UNITED STATES PATENT OFFICE.

WINFIELD SCOTT RUSSELL, OF NEW YORK, N. Y.

FOUNTAIN INK-WELL.

SPECIFICATION forming part of Letters Patent No. 523,010, dated July 17, 1894.

Application filed January 27, 1894. Serial No. 498,191. (No model.)

To all whom it may concern:

Be it known that I, WINFIELD SCOTT RUSSELL, a citizen of the United States, and a resident of the city, county, and State of New York, have invented certain new and useful Improvements in Fountain Ink - Wells, of which the following is a specification.

This invention relates to fountain ink-wells and has for its object to provide a simple, cheap and easily constructed device of this character by means whereof, the ink will not only be securely protected from the air and prevented from spilling, even should the ink-well be overturned, but which may also be refilled without removing the cover, or other of the parts thereof.

A further and particular object of the invention is to obviate one of the main disadvantages of the present form of fountain ink-stand, wherein, when the funnel is hastily depressed by the pen, it is not infrequently pushed inward, so far or so forcibly, as to cause the ink to overflow the funnel and run down the sides of the ink-well. It has been attempted to avoid this by making the tube of the funnel of such a length as to abut against the bottom of the well when sufficiently depressed, but this is only possible when each funnel is specifically made for some one ink-stand, instead of, as preferably, being adapted to any form or size, and moreover since it has as yet been found practically impossible to manufacture any two glass ink-wells absolutely alike interiorly, considerable difficulty is encountered in making these tubes and wells correspond and fit together.

The invention, which is primarily designed to overcome these manifold faults and difficulties, consists in the novel construction and arrangement of parts hereinafter more fully described and particularly set forth.

In the accompanying drawings, forming part of this specification, in which like letters of reference designate corresponding parts throughout all the views, Figure 1 is a perspective view of an ink-well embodying my invention. Fig. 2 is a transverse vertical section through the center of the ink-well, illustrating the various elements and features constituting my device. Fig. 3 is a similar view

of the central funnel and tube when removed, and Fig. 4 is a section of the said funnel on the line $x-x$ Fig. 3.

Upon the ink-well A, which is preferably square in shape and made of glass, I form a collar or rim, a , externally screw-threaded and having thereon the ledge a' . Resting on this ledge is a rubber disk b having the usual opening in the center for the funnel, surrounding which is the lip b^2 . Over the disk is placed the cover B internally screw-threaded, and engaging with the rim a . This cover also has at its center an opening B' considerably larger than the opening b' in the disk. Within the opening b' is fitted the funnel c having the peripheral groove d therein, in which groove the lip b^2 of the disk b extends, space being left between the said lip and the roof of the groove at the top and the bead c' at the bottom. The funnel has depending therefrom the tube e , integral therewith, and projecting downward to within a short distance of the bottom of the well. At equidistant points in the funnel are formed air-holes f extending through the neck thereof and opening into the groove in the form of slots f' . Upon the funnel at the exterior of its top or mouth I provide an annular flange g tapering outward and appreciably wider than the opening B' in the cover.

The pen depressing the funnel, the ink flows through the tube e into the same, the flange g abutting against the cover and preventing the funnel from being forced too far inward. The disk b bears against the roof of the groove d in the funnel and prevents any air from entering the well. The disk also serves to restore the funnel to the raised position.

When it is desired to fill the ink-well the funnel is slightly raised and the groove d being wider than the disks and the slots f' extending from top to bottom thereof, the said disks bearing upon the bead c' leaves a space above the same thus connecting the air with the air-holes f , whereby the air within the well may escape and permit the ink to be poured therein through the funnel.

I do not claim broadly the use of a rubber disk, nor the bare principle of providing the funnel with air-holes, as I am aware that ink-

stands have been made heretofore embodying the general outlines of each of these features; but

What I do claim as new, and desire to secure by Letters Patent, is—

1. In a fountain ink-well, a funnel having a flange upon the top thereof, a peripheral groove therein and air-holes in the base thereof opening into the groove, substantially as shown and described.

2. In a fountain ink-well, the combination with a well, a cover therefor, and a funnel having a peripheral groove therein and air-holes in the base thereof opening into slots in the groove, of a rubber disk surrounding the funnel at the groove, and of less thickness than the depth thereof, substantially as shown and described.

3. In a fountain ink-well, the combination with a well, a cover therefor, and a funnel having an annular flange at the top thereof, a peripheral groove therein and air-holes in the base thereof opening into slots in the groove, of a rubber disk surrounding the funnel at the groove and of less thickness than

the depth thereof, substantially as shown and described.

4. In a fountain ink-well, the combination with a well, a cover having an opening therein, and a funnel within the said opening having an annular flange thereon projecting beyond the said opening to act as a stop, a peripheral groove in the said funnel, and air-holes in the base thereof opening into slots extending from top to bottom of the groove, of a rubber disk intervening the well and the cover and surrounding the funnel at the mouth, a lip upon the said funnel of less thickness than the depth of the said funnel, whereby the air-holes may be connected with the air, substantially as shown and described.

In testimony that I claim the foregoing as my invention I have signed my name, in presence of two witnesses, this 25th day of January, 1894.

WINFIELD SCOTT RUSSELL.

Witnesses:

PERCY T. GRIFFITH,
EDGAR TATE.