

July 17, 1934.

H. W. COE

1,966,884

CONTAINER FOR LIP STICKS OR THE LIKE

Original Filed Dec. 2, 1932

Fig. 1

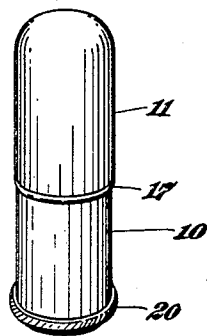

Fig. 3

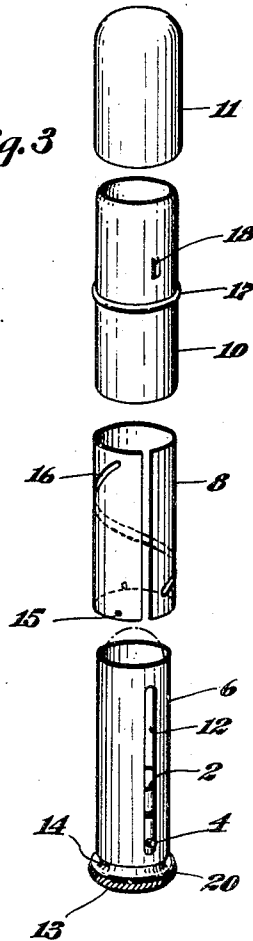

Fig. 2

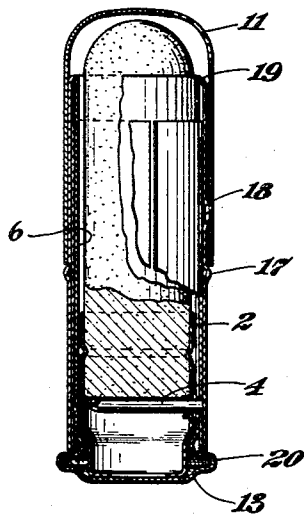
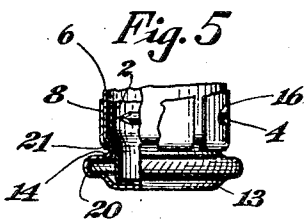
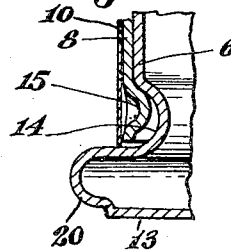

Fig. 4



INVENTOR

Herbert W. Coe,

BY

Bartlett, Lyre, Scott & Keel
ATTORNEYS

UNITED STATES PATENT OFFICE

1,966,884

CONTAINER FOR LIP STICKS OR THE LIKE

Herbert W. Coe, Waterbury, Conn., assignor to
The Waterbury Brass Goods Corporation,
Waterbury, Conn., a corporation of Connecticut

Application December 2, 1932, Serial No. 645,367
Renewed January 3, 1934

4 Claims. (Cl. 206—56)

The present invention relates to an improved lipstick container of the type adapted upon relative rotation of the parts to project the lipstick or other cosmetic beyond the open end of the container. The improved container is constructed of relatively simple parts adapted to be readily assembled and when assembled to be positively and securely retained in operative relation.

For an understanding of the various features of novelty of the improved lipstick container reference may be had to the accompanying drawing of which:

Fig. 1 is a perspective view of the new container;

Fig. 2 is an enlarged sectional view of the container of Fig. 1 with parts shown in elevation;

Fig. 3 is an exploded view of the container of Fig. 1 showing in perspective the various parts thereof;

Fig. 4 is an enlarged sectional view of a portion of the container; and

Fig. 5 is a fragmentary view partly in section illustrating an alternative arrangement of a portion of the container.

The container comprises the lipstick carrier member 2 through one wall of which a pin 4 projects, a cylindrical shell 6 enclosing the carrier 2, a sleeve member 8, an outer casing member 10 and a closure or cover section 11. The carrier member 2 is freely movable longitudinally in the shell 6, but is prevented from rotation therein by means of the pin 4 which projects through a longitudinal slot 12 in the wall of the shell. Shell 6 is open at its upper end and is closed at its lower end by a base section 13 integral therewith. At the lower end of the shell adjacent the base section 13, is an annular groove 14 serving together with inwardly projecting lugs 15 on the inner surface of the sleeve 8 to key members 6 and 8 together to prevent relative longitudinal movement therebetween. Sleeve 8 is provided with a spiral slot 16 adapted to receive the end of pin 4 projecting through slot 12 and to guide the same upon relative rotation of members 6 and 8. To prevent relative rotation between the casing 10 and sleeve 8, the latter is preferably of spring material and is in the form of a cylinder of an external diameter slightly greater than the internal diameter of the casing 10 but longitudinally split to permit the casing to be forced thereover. With this arrangement the outward spring pressure of the sleeve insures frictional engagement with the casing and prevents rotation of the sleeve. Casing 10 is provided with an annular shoulder 17 for engagement with the open end

of the closure member 11 and with outwardly projecting lugs 18 for frictional engagement with the inner surface of the closure member. Any other suitable means for insuring a frictional grip between the closure member and casing may, of course, be provided if desired. Preferably the upper end of casing 10 is tapered or turned slightly inward as indicated at 19 (Fig. 2) to give a neat appearance when the closure 11 is removed; the tapered portion 19 concealing the upper edge of the relatively shorter sleeve 8. The outer surfaces of casing 10 and cover 11 may be enameled or otherwise decorated as desired.

In order to project or retract the lipstick it is only necessary to rotate the shell 6 relative to the sleeve 8 and casing 10 as such rotation causes longitudinal travel of the carrier 2 in response to the travel of the pin 4 in the cooperating slots 12 and 16. In order to effect such rotation, the base 13 of shell 6 is preferably provided with an annular bead 20 which is knurled or otherwise roughened to provide a convenient gripping surface.

The provision of the annular groove 14 in the lower end of shell 6 and of the cooperating lugs 15 on the inner surface of sleeve 8 effectively prevents longitudinal movement of the sleeve while interfering in no way with the rotational movement required for operation of the device. Lugs 15 could, of course, be replaced by an annular ring or band on the inner surface of sleeve 8 adapted to fit into the groove 14 or, if desired, the lugs 15 could be omitted and the lower edge of sleeve 8 turned inwardly as indicated at 21 in the modification illustrated in Fig. 5; the inwardly turned edge 21 extending into the groove 14 sufficiently to prevent longitudinal movement between members 6 and 8 but not to such an extent as to prevent relative rotation thereof.

The swivel connection between the lower end of the spirally slotted sleeve 8 and the shell 6 as above described, enables the parts to be easily assembled in manufacturing, and provides for free and smooth turning movement without danger of the parts binding or working loose or otherwise getting out of order while in use.

The following is claimed:

1. In a container for a lipstick or the like, a carrier for the lipstick having a pin projecting from a side thereof, a shell for receiving said carrier having its lower end closed and its upper end open, a radially compressible sleeve of spring material surrounding said shell, a casing surrounding said sleeve and radially compressing the same to prevent by friction relative rotation

therebetween, and a swivel connection between the lower end of said sleeve and said shell, said shell and sleeve having angularly arranged slots through which said pin extends.

5 2. A container for lipstick or the like comprising in combination a cylindrical shell open at one end and closed at its other end, said shell being provided with an annular groove adjacent its closed end and with a longitudinal slot, a radially compressible sleeve of spring material positioned
10 about said shell and provided with a helical slot, said sleeve having inwardly projecting portions adapted to be forced into said groove and to cooperate therewith to prevent relative longitudinal
15 movement of said shell and said sleeve, a lipstick carrier positioned within said shell, a pin secured to said carrier and projecting through both of said slots to cause longitudinal movement
20 of said carrier upon rotation of said shell within said sleeve, a cylindrical casing positioned about said sleeve and shell so as to conceal the same and forcing said inwardly projecting portions into said annular groove by radial compression
25 of said sleeve, and a closure for the upper end of said casing, the closed end of said shell extending beyond said sleeve and casing to provide a gripping surface for rotation of said shell.

3. A lipstick container comprising in combination a cylindrical longitudinally slotted shell
30 having an open upper end and a closed lower end, the lower end of said shell being provided with a circumferential groove, a spirally slotted radially compressible sleeve of spring material about said shell provided with inwardly projecting lugs
35 adjacent its lower end and adapted when positioned within said circumferential groove to per-

mit relative rotation of the sleeve and shell while preventing relative longitudinal movement thereof, a carrier within said cylindrical shell, a pin secured to said carrier and projecting through the slots in said sleeve and shell, and
30 an outer casing, open at its lower end, positioned about said sleeve and shell and radially compressing said sleeve to force said inwardly projecting lugs into said circumferential groove, the closed
35 end of said shell extending sufficiently beyond said casing to provide a gripping surface for manually rotating said member within said casing to cause longitudinal movement of said carrier with travel of said pin in said slots.

4. A lipstick container comprising in combination a longitudinally slotted cylindrical shell having an open upper end and a closed lower end, the upper end of said member being smooth and the lower end being provided with a circumferential groove and with an annular bead, a helically
40 slotted and radially compressible sleeve of spring material positioned about said shell, the lower end of said sleeve being turned inwardly to enter said groove to prevent longitudinal movement of said sleeve upon said shell, a lipstick carrier
45 within said shell, means associated with said carrier and operative in the longitudinal and helical slots of said shell and sleeve for causing longitudinal movement of said carrier upon rotation of said shell, and a casing so positioned
50 about said sleeve and shell as to conceal the same while exposing said bead for rotation of said shell said casing radially compressing said sleeve to prevent by friction relative rotation therebetween.

HERBERT W. COE.

40

115

45

120

50

125

55

130

60

135

65

140

70

145

75

150