



- (51) **International Patent Classification:**
F16J 15/06 (2006.01) E06B 7/22 (2006.01)
B32B 27/40 (2006.01)
- (21) **International Application Number:**
PCT/US2016/026760
- (22) **International Filing Date:**
8 April 2016 (08.04.2016)
- (25) **Filing Language:** English
- (26) **Publication Language:** English
- (30) **Priority Data:**
62/144,381 8 April 2015 (08.04.2015) US
- (71) **Applicant: AVIATION DEVICES & ELECTRONIC COMPONENTS, L.L.C.** [US/US]; 3215 W Loop 820 S, Fort Worth, TX 76116 (US).
- (72) **Inventors: BUSBY, Jeff;** 3655 Lazy Bend, Millsap, TX 76060 (US). **BOOMER, Kent;** 119 Highland Dr., Aledo, TX 76008 (US). **BOYD, Matt;** 3529 Wosley Dr., Fort Worth, TX 76133 (US). **SAMUELSON, Emily;** 1916 Canterbury Dr., Fort Worth, TX 76107 (US).
- (74) **Agent: CHAPMAN, Daniel, D.;** Jackson Walker, LLP, 112 East Pecan, Suite 2400, San Antonio, TX 78205 (US).
- (81) **Designated States** (*unless otherwise indicated, for every kind of national protection available*): AE, AG, AL, AM,

AO, AT, AU, AZ, BA, BB, BG, BH, BN, BR, BW, BY, BZ, CA, CH, CL, CN, CO, CR, CU, CZ, DE, DK, DM, DO, DZ, EC, EE, EG, ES, FI, GB, GD, GE, GH, GM, GT, HN, HR, HU, ID, IL, IN, IR, IS, JP, KE, KG, KN, KP, KR, KZ, LA, LC, LK, LR, LS, LU, LY, MA, MD, ME, MG, MK, MN, MW, MX, MY, MZ, NA, NG, NI, NO, NZ, OM, PA, PE, PG, PH, PL, PT, QA, RO, RS, RU, RW, SA, SC, SD, SE, SG, SK, SL, SM, ST, SV, SY, TH, TJ, TM, TN, TR, TT, TZ, UA, UG, US, UZ, VC, VN, ZA, ZM, ZW.

- (84) **Designated States** (*unless otherwise indicated, for every kind of regional protection available*): ARIPO (BW, GH, GM, KE, LR, LS, MW, MZ, NA, RW, SD, SL, ST, SZ, TZ, UG, ZM, ZW), Eurasian (AM, AZ, BY, KG, KZ, RU, TJ, TM), European (AL, AT, BE, BG, CH, CY, CZ, DE, DK, EE, ES, FI, FR, GB, GR, HR, HU, IE, IS, IT, LT, LU, LV, MC, MK, MT, NL, NO, PL, PT, RO, RS, SE, SI, SK, SM, TR), OAPI (BF, BJ, CF, CG, CI, CM, GA, GN, GQ, GW, KM, ML, MR, NE, SN, TD, TG).

Declarations under Rule 4.17:

- *as to the applicant's entitlement to claim the priority of the earlier application (Rule 4.17(iii))*
- *of inventorship (Rule 4.17(iv))*

Published:

- *with international search report (Art. 21(3))*

(54) **Title:** A METAL MESH WITH A LOW ELECTRICAL RESISTANCE CONVERSION COATING FOR USE WITH AIR-CRAFT STRUCTURES

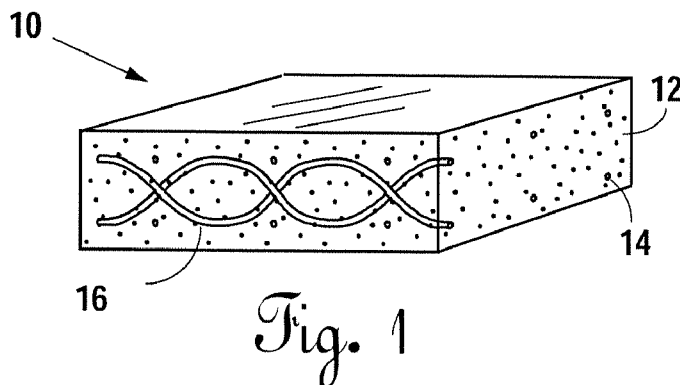

(57) **Abstract:** A gasket is provided with a tacky polyurethane or polyurea gel body and a metallic mesh skeleton where the skeleton has been coated with a conversion coating. The conversion coating helps reduce corrosion in the gasket and corrosion on the parts that place the gasket under compression, especially where an environment conducive to galvanic corrosion is present. This gasket may then be used in assemblies which include aircraft parts, which parts may be subject to extreme environmental conditions.

WO 2016/164803 A1

**TITLE: A METAL MESH WITH A LOW ELECTRICAL RESISTANCE
CONVERSION COATING FOR USE WITH AIRCRAFT STRUCTURES**

FIELD OF THE INVENTION

[1] Aircraft structures including gaskets, more particularly, structures having a metallic skeleton or other metallic substrate which, in some embodiment, is coated with a conductive or semi-conductive chromate coating.

BACKGROUND OF THE INVENTION

[2] Gaskets are typically provided for maintaining an environmental seal between two pieces under compression. Gel type gaskets, including gel type gaskets with metallic woven skeletons are known, including those found in applicants patents US 6,695,320, 6,530,577 and 7,229,516 incorporated herein by reference.

[3] This invention relates to the surface treatment of metals to form a thin protective electrically conductive surface on an aluminum mesh, which mesh may be encapsulated in a cured polyurethane gel for use as a gasket between two aircraft parts, such as an aircraft antenna and an aircraft fuselage, where EMI protection is desired.

[4] This invention includes a process for passivated aluminum or aluminum alloy where the aluminum or aluminum alloy may be used in an electrochemically active environment without material corrosion.

SUMMARY OF THE INVENTION

[5] Applicant provides a gel bodied gasket with a gel encapsulated coated metallic skeleton member such as aluminum or aluminum alloy. The metallic skeleton has been subject to a chemical conversion coating which coating is bonded to the metallic skeleton, which chemical conversion coating is conductive or semi-conductive. The chemical conversion coating will provide corrosion resistance to the metallic skeleton, especially in an

environment subject to electrical current or electric fields between metallic pieces under compression. One such environment, for example, is an antenna gasket in which the transmitting/receiving antenna may generate a potential difference between the antenna and the fuselage to which it is mounted. In such an environment, it is sometimes helpful to have a gel gasket to provide good environmental sealing along with a gel embedded metallic mesh skeleton to provide conductivity by way of contact between the two pieces under compression and the metallic skeleton. However, when metal mesh skeleton is used, such as an aluminum mesh, it may be subject to corrosion due to environmental chemicals or other factors which corrosion may be enhanced by an electrical field about the antenna or a potential difference between the opposed metal parts.

[6] Applicant discloses a gasket for use between aircraft parts under compression, the gasket body is provided having a tacky elastomeric gel. A metal skeleton is encapsulated by the body of the gasket. The metal skeleton is encapsulated by the body of the gasket. The metal skeleton includes a thin conversion coating. The body may be a polyurethane gel. The metal skeleton may be an aluminum or aluminum alloy mesh. The resistance of the coated aluminum or aluminum alloy mesh is typically less than about 2.5 milliohms. The conversion layer, in one embodiment, is formed from a reaction of either a hexavalent chromium or a trivalent chromium. The conversion coating may include a non-hexavalent chromium coated to between about 100 – 250 mg/dm². The elastomeric gel may be a polyurethane and the gel may include a non-hexavalent chromium. The gel may include conductive particles or fibers. A second mesh skeleton may be provided, which may be metallic.

[7] A method of producing a noncorrosive assembly is disclosed comprising: contacting an aluminum alloy exterior surface of an aluminum wire mesh or expanded metal aluminum with a composition comprising a trivalent chromium salt and an alkali metal hexafluorozirconate to form a surface coating on the aluminum or aluminum alloy surface and encapsulating the aluminum wire mesh into a tacky gel bodied gasket for use with aircraft parts. The parts may be subject to an electrical potential therebetween and the conversion coating may be electrically conductive, but inhibit galvanic corrosion on the mesh.

[8] The objects of the disclosures set forth herein include providing for a chromium-based conversion coating on a metallic skeleton (such as an aluminum alloy mesh) which coating is thin enough to provide for electrical conductivity, but thick enough to provide for corrosion resistance in an electrochemically active environment such as where RF interference may be a problem between an aircraft antenna and an aircraft fuselage.

BRIEF DESCRIPTION OF THE DRAWINGS

- [9] Fig. 1 is a cutaway perspective view of a composite that uses Applicant's conversion coated metallic mesh fabric.
- [10] Fig. 2 is a cross-sectional view of a strand of conversion coated metal skeleton having a coated end.
- [11] Fig. 3 is a cross-sectional view of an assembly comprising aircraft parts under compression with Applicant's composite therebetween.
- [12] Fig. 4 is a flow chart showing steps taken for passivating a metal with a conversion coating of a chromium compound.
- [13] Fig. 5 is a cross-sectional view of a strand having an uncoated end.
- [14] Fig. 6 is a cross-section of an embodiment of Applicant's composite as part of an assembly comprising aircraft parts under compression.
- [15] Fig. 7 is a more detailed flow chart showing steps taken for passivating a metal with examples of a conversion coating of a chromium compound.
- [16] Figs. 8 (cut finished gasket) and 8A (sealed uncoated strand ends) illustrate a coat, pour and cut method of preparing a gasket according to these specifications that leave uncoated strand ends.
- [17] Figs. 9 (cut), 9A (coat), and 9B (pour) illustrate a cut, coat and pour method of preparing a gasket according to these specifications.
- [18] Figs. 10 and 11 illustrate a typical salt fog test assembly (in pieces), front side and opposite or back side, prior to exposure.
- [19] Fig. 12 illustrates the test assembly, front and back side, prior to exposure in the salt fog chamber.
- [20] Figs. 13 and 14 illustrate the SurTec skeleton pre-cut (and then conversion coated thus leaving strand ends coated) disassembled after 500 hours of salt fog, front side and opposite side.
- [21] Figs. 15 and 16, close-up of Figs. 14 and 15 on aircraft side and antenna base side after 500 hours.
- [22] Figs. 17-21 all illustrate results for SurTec post-cut (cutting skeleton after conversion coating thus leaving strand ends uncoated).
- [23] Fig. 17 illustrates front and back side of the test assembly assembled together.
- [24] Figs. 18 and 19 illustrate front and back SurTec wire post-cut assembly after 500 hours of exposure.
- [25] Figs. 20 and 21 show aircraft side and antenna base side after 500 hours of salt fog exposure.

[26] Figs. 22-25 illustrate control, no conversion coating, same aluminum mesh, same article being tested, with Figs 22, 23, 24, and 25 showing the corrosion results for the control assembly.

[27] Figs. 26-30 illustrate results for a post-cut Alodine treated wire mesh skeleton after 500 hours of salt fog exposure.

[28] Fig. 26, front and back of typical test assembly prior to exposure.

[29] Figs. 27 and 28 disassembled front and back sides of test assembly after 500 hours of exposure.

[30] Figs. 29 and 30, close-ups of aircraft side and antenna base side after 500 hours of exposure.

[31] Figs. 31-35 show Alodine treated pre-cut after 500 hours of salt fog.

[32] Fig. 31, typical test assembly, front and back, prior to exposure.

[33] Figs. 32 and 33, front and back disassembled, after 500 hours of exposure.

[34] Figs. 34 and 35, front and back (aircraft side and antenna base side) after 500 hours of salt fog exposure.

DETAILED DESCRIPTION OF THE ILLUSTRATED EMBODIMENTS

[35] Figs. 1, 2, 3, 5, and 6 illustrate embodiments of applicants composite 10, and assemblies including Applicant's composite which, in some embodiments, comprise a gasket. In one embodiment, the composite may comprise a gasket having a Body 12 (in some embodiments, a tacky gel body) with a metallic skeleton 14, which metallic skeleton contains a thin conversion coating 19 as set forth herein. The skeleton may be a metal mesh skeleton comprising multiple strands 16 of aluminum or aluminum alloy cylindrical wire that are woven together to form the mesh usually an open weave mesh, similar to the mesh of a screen door. The skeleton may also be a metal, such as expanded aluminum. Fig. 2 illustrates that the individual strands (or the metal of a non-strand skeleton) may be coated in some embodiments even across a strand end as when a "cut-to-fit" gasket mesh is dipped in a bath of a conversion coating solution. Fig. 3 illustrates a use of applicants composite, in this embodiment a gasket having a gel body, between a movable part 22 and a base 24 with the movable part under compression against the base, as by fasteners, for example. Note in the embodiment illustrated, the opposed mating surfaces are flat or slightly curved and match one another and may be metallic, in one case at least one of the parts is aluminum or aluminum alloy. The skeleton and body are typically flexible enough to allow the gasket to fit a slight curvature and the gel is deformable and flowable under compression.

[36] Body 12, typically a tacky polyurethane gel, substantially encapsulates the metal conversion coated skeleton 14 the gel body, in some embodiments, extending above and below the mesh in a first range of about 0 to 50 mil. as seen in Fig. 1 or a second, preferred range of about 10 to 30 mil. Body 12 may also be made of a sealant such as a fast setting, clear, two component polyurea available as Part Number SF2470 from KBS Chemical, Dodd City, Texas. The KBS material is a two-component urethane material designed for use as a watertight, flexible sealant. The low viscosity allows the material to be sprayed. The transparent nature of the sealant allows for inspection through the material, such as the skeleton, without removal. The system demonstrates excellent adhesion to itself (cohesion) and allows for easy removal from the aircraft parts when necessary.

[37] In one embodiment, body 12 may comprise a two-part, cured, tacky, elastomeric polyurethane gel as set forth in the patents incorporated herein by reference, in one case the gel body having a hardness of between about 40 and 150 durometer. When composite 10 is under compression between movable part 22 and base 24, as when fasteners may be torqued down, the gel, being soft, deforms and, typically, some will squeeze out. This allows the movable part to come in contact with the upper surface of the metal mesh, forcing the metal mesh against the lower surface of the base, thereby providing an electrically conductive path between movable part 22 and base 24

[38] Applicant discloses two similar processes and three resulting products, both processes and products resulting in a chemical conversion coating to a metallic skeleton or mesh, which coating is a thin electrically conductive coating but provides for some corrosion resistance.

[39] Fig. 5 illustrates an uncoated strand end. Uncoated strand ends may occur when a coated wire mesh skeleton 14 is die cut as set forth herein and in the patents incorporated herein by reference. Fig. 3 illustrates a conversion coating 19 on the exposed surfaces of the wire forming the mesh skeleton 14.

[40] The thickness and therefore the electrical resistance of the conversion coating may be controlled by the time in which the skeleton is immersed in the conversion coating solution (SurTec 650 or Alodine, for example) with a longer period of time creating the thicker coating.

[41] Fig. 6 illustrates the use of a perimeter sealant between movable part 22 and base 24, wherein composite 10 in one embodiment is slightly undercut leaving a gap, which gap is filled with a perimeter seal 26 such as AvDec Thixoflex® Orange, a two part elastomeric cure in place sealant (hardness about 55 to 75 shore "oo") or AvDec Thixoblack®, a firmer (about 70 to 90 durometer shore "A") perimeter sealant.

[42] Fig. 4 illustrates that both conversion coating processes involve the steps of degreasing, chemically etching, then rinsing (together referred to as cleaning) and then chemically converting a surface of a metallic skeleton with a reactive composition that may contain chromium such that the coating contains, in some embodiments, either a trivalent or hexavalent chromium. The chemical conversion provides a chemical conversion coating, in one embodiment, by dipping an etched mesh skeleton in a conversion chemical. The coated metallic mesh is then embedded in a tacky gel (in one case polyurethane) and used as a gasket in a number of settings, some (such as an aircraft antenna) of which involve the use of aircraft parts under compression and subject to EMI (electromagnetic interference).

[43] In one embodiment, the aluminum alloy of the mesh to be coated may be 2, 3, 5 or 6000 series alloy and in one embodiment is 5053 aluminum. Prior to coating, the base metal is mechanically or chemically cleaned such that a water break – free surface is obtained after rinsing. Abrasives containing iron, such as steel wool and the like should not be used for cleaning. The chemical conversion coating may be applied non-electrolytically by spray, brush, or immersion on the formed aluminum wire, open weave mesh. The chemical conversion coating should be continuous in appearance and visibly discernible in daylight. It should be free from areas of powdery and loose coating, scratches, flaws and other defects for damages which reduce the corrosion protective value of the coating. A cleaner designed to chemically etched aluminum or aluminum alloy may be used. In one case, an acid etch may be used on 5053 aluminum alloy.

[44] In one embodiment, the reactive composition providing the chemical conversion coating is an aqueous acidic solution which contains trivalent or hexavalent chromium. In a second embodiment, the reactive composition providing the chemical coating is Alodine® 1201 (a registered trademark of Henkel Surface Technologies) or SurTec 650 ChromitAL® (a registered trademark of SurTec International). The former provides for conversion coating comprising a hexavalent chromate and the latter a conversion coating comprising a trivalent chromate. Both materials form protective coatings by a chemical reaction with aluminum or aluminum alloys on the surface of the skeleton. Any suitable aqueous acidic solution containing trivalent or hexavalent chromate or suitable equivalents may be used. A hexafluorozirconate from an aqueous solution of dipotassium hexafluorozirconate, for example, may be used in conjunction with the chromate, or as an additional protective layer.

[45] The weight of the passivation or conversion coated layer 19 depends, in part, on the roughness of the aluminum surface. Passivation layers with good corrosion resistance may, in some embodiments, have a weight of approximately .11 – 0.5 grams per square meter. Immediately upon drying of the treated surface, treated surfaces may be assembled

with a two part polyurethane cure in place gel to form a gasket. Drying time may be room temperature up to about 100°C and, in one embodiment, about 65°C, however, room temperature is preferred.

[46] Spraying, brushing or wiping may also be used to apply the reactive chemical composition. A solution of 20% by volume of SurTec 650, 80% by volume of dionized water may be used. In some embodiments, the optimum coating weight may be between about 100 to 250 mg/dm² for conductive conversion coatings.

[47] Mil spec MIL – DTL – 5541F describes procedures for coating aluminum to produce a chemical conversion coating. While this mil spec describes the conversion coating of aluminum alloy flat sheet or plate, some of the information and disclosure may be utilized as set forth herein for the chemical conversion of an aluminum mesh or expanded metal or fabric comprised of multiple woven electrically conductive strands.

[48] The conversion coatings may be applied to aluminum or aluminum alloy woven mesh substrates that are not anodized. The coating will inhibit galvanic corrosion. Coating thickness is varied by immersion time and as a result, the electrical conductivity can be controlled, – a thinner conversion coating yielding a metal with lower electrical resistance.

[49] When under a nominal electrode pressure of about 200 psi, thin coatings may be tested under MIL – DTL – 81706 to have a resistance not greater than 5,000 microhms (5 milliohms) per square inch and 10,000 microhms (10 milliohms) per square inch, after 168 hours of salt spray exposure. A preferable resistance is 2.5 milliohms or less. Other variables may affect resistance values other than coating thickness. These include surface roughness of the specimen, with rough surfaces yielding lower resistance values due to coating fracture. Moreover, if the surface area is not flat, such as in a woven aluminum alloy mesh, the actual contact points will be lower points, and a smaller contact area may result in a higher resistance value.

[50] MIL-C-5541 Class 3 conversion coatings are required to have less than 200 milliohms of resistance when measured at 200 psi contact pressure after 168 hours of exposure to a 5% salt spray. In some embodiments, including those set forth below, the conversion coatings meet these parameters.

[51] SurTec 650 – Determination of the Layer Weight

[52] Equipment: Analytical balance (+ / - 0.1 mg)

[53] Reagents: 50% vol. nitric acid (65%)

[54] Procedure:

[55] 1. Passivate a test part with a known surface area in m² (preferably) > 2 dm²) in SurTec 650.

[56] 2. Rinse with deionized water and dry with compressed air at room temperature.

- [57] 3. Weigh the dry part within 3 h after passivation with the analytical balance (= M_1).
- [58] 4. Remove the passivation layer in nitric acid (4 min at 20-25° C).
- [59] 5. Rinse with deionized water and dry with compressed air at room temperature.
- [60] 6. Weigh the dry part again with the analytical balance (= M^2).
- [61] 7. Repeat the analysis with a cleaned and deoxidized but not –passivated test part
(= M_3 and M_4)
- [62] Calculation:
- [63] $(M^1 - M^2) / \text{surface area} = A$
- [64] $(M^3 - M^4) / \text{surface area} = B$
- [65] $A - B = \text{layer weight in g/m}^2$
- [66] Hint: For determination of the layer weight always a fresh solution should be used.
At the latest after 1 m²/l the solution has to be renewed.
- [67] Two examples of conversion coatings are set forth below. These may be prepared
by guidelines of the manufacturers, or those set forth in Fig. 7.
- [68] Example A (Alodine coated mesh, Figs. 26-35)
- [69] Henkel Alodine 1201 Conversion Coating Treatment -
- [70] Alodine 1201 is a conversion coating (sometimes called “passivation”) for aluminum
or aluminum alloy, the reactive coating composition containing hexavalent (VI) chromium.
It is nonflammable, chromic and acid-based and will produce a conversion coating on
aluminum and its alloys. The coating formed by Alodine 1201 is gold to tan in color, and it
becomes part of the aluminum surface. It offers good paint adhesion and corrosion
resistance, but preserves electrical conductivity of the surface. While referred to as a
coating, it is (like SurTec 650) actually a chemical treatment to the outer surface of the
metal and will not materially change the dimensions of the workpiece. In some
embodiments, it may be applied by brush or immersion.
- [71] Alumiprep 33 is one product recommended for pre-immersion cleaning. Alumiprep
33 is a nonflammable phosphoric acid-based cleaner that produces a chemically cleaned
and corrosion free aluminum surface. After cleaning the metal should be thoroughly rinsed
with water. To apply Alodine 1201, the product may be used undiluted or diluted by mixing
about 33 parts of Alodine with about 67 parts of water for each 100 parts of bath volume
required. Room temperature to about 100° F is the usual temperature of operation and the
time of immersion may be about 2 to 5 minutes, depending upon how much coating is
required. Colors of the coating produced will vary from light gold to a dark tan. After
treatment, the workpiece should be thoroughly rinsed with water. As an aid to drying, the
treated part may be heated or blown off with clean, dry, filtered, forced air, or it may be
gently wiped with a dry, clean rag.

[72] Applicant manufactures products that are currently in use solving a wide variety of corrosion problems with non-hazardous polyurethane based products on commercial and military aircraft. This presents the results of salt fog exposure testing performed on various embodiments of Applicant's materials with coated mesh. Applicant's materials with coated mesh were tested by salt fog exposure in accordance with ASTM B117 to simulate accelerated real world application scenarios and to evaluate the effectiveness for corrosion prevention.

[73] Materials under test:

[74] Woven Mesh – Al 5056 18 strand/in each direction, .017 inch strand diameter, gel thickness .035 in.

[75] Test A1 Coated Mesh – Cut before alodine treatment (strand ends coated)
(Figs. 32-35)

[76] Test A2 Coated Mesh – Cut after alodine treatment (strand ends uncoated)
(Figs. 27-30)

[77] Test A3 Regular Mesh – Conductive antenna gasket (uncoated control)
(Figs. 22-25)

[78] For Alodine treatment:

[79] Mix 33 parts Alodine to 67 parts deionized water;

[80] Soak mesh sample in Alodine for 2-5 minutes room temperature;

[81] Dunk and rinse sample in deionized water; and

[82] Allow to air dry (room temperature and humidity) for 24 hours.

[83] In-Application Assembly

[84] The test samples were made by applying the test specimen between two test coupons. The test coupons are one 2024 T3 Aluminum coupon, representing typical aircraft skin material, measuring 4" x 4" and one 6061 T6 Aluminum coupon, representing typical antenna base material, measuring 3" x 3". Each test coupon was scuffed with a Scot Brite pad and cleaned with a paper towel moistened with isopropyl alcohol before use. Four 8-32 stainless steel fasteners were electrically isolated using heat shrink sleeving around each fastener shank and Kapton tape under the steel washers on both sides. The fasteners were tightened to 17 in*lbs and retightened after 15 minutes (see Fig. 12 for a standard test assembly). After the fasteners had been tightened a second time, resistance was measured. Following removal from the salt fog chamber, resistance was measured again.

[85] Each test assembly was photographed, the resistance was measured, and the samples were placed in the salt fog chamber. The specimen was supported or suspended between 15° and 30° off vertical so that one assembly would not drip on another. The

assemblies did not contact each other or any metallic material. Test assemblies were exposed for a duration of 500 hours. At the end of each test duration, the test assembly was removed from the chamber, the salt deposits on surface were rinsed off, the resistance was measured, and the test assemblies were photographed before and after disassembly.

[86] The testing apparatus consisted of a closed fog chamber in which a solution of 5% sodium chloride is atomized by a nozzle thus producing a dense saline fog. The apparatus also contains a salt solution reservoir, a supply of compressed air, specimen supports, and a means for control. The test samples are exposed to this severe corrosive environment. The chamber is a Singleton SCCH 21 chamber and is accepted by ASTM-B-117.

[87] Example B (SUR-TEC 650, Figs. 10-25))

[88] SurTec 650® ChromitAL TCP Conversion Coating Treatment –

SurTec 650 a reactive composition, provides a conversion coating for aluminum alloy such as 2, 5, 6, or 7,000 series aluminum alloy. SurTec 650® provides a coating that is free of hexavalent chromium. It may be disposed as normal waste. Coating may be by immersion. The time of immersion may be between about 1 to 5 minutes at a temperature preferably above 10° C and below about 50° C. Pretreatment may range from about 30-40° C, temperature will influence bath time (warmer temperature lowers coating time). With a higher bath temperature for immersion, a shorter immersion time is sufficient. For good corrosion protection, for example, at 30°C, about four minutes (range about 2-6 minutes). Passivation (conversion) during dip (immersion) typically occurs at about pH 3.75 to 4 (may be adjusted with sulfuric acid or sodium hydroxide), concentration about 20% at about 30° C for about five minutes. In one embodiment, the optimum coating weight for a conductive coating of SurTec is about 100 to 250 mg/dm² square for EMI shielding (ASTM D – 4935).

[89] SurTec 650 meets MIL-DTL-81706B and MIL-DTL-5541F for bare metal corrosion (336 h NSS per ASTM B-117). It produces a heat resistant inorganic passivation layer. Further details may be found in the following US patents incorporated herein by reference: 6,375,726; 6,511,532; 6,521,029; 6,527,841. The standard procedure for immersion typically requires degreasing, deoxidizing using, for example, a chromium-free liquid desmutting product (e.g., SurTec 495) and, if silicium is less than 1%, alkaline etching using an appropriate alkaline etching solution (e.g., SurTec 181). Between each step, the surface has to be rinsed. Prior to passivation with SurTec 650, the aluminum surface must be cleaned and deoxidized thoroughly. The surface must be water-break free.

[90] Materials under test:

[91] Woven Mesh – Al 5056 18 strand/in each direction, .017 inch, gel thickness about .035"

- [92]** Test B1 SurTec Treated Aluminum Mesh – Cut before SurTec treatment (Figs. 13-16)
- [93]** Test B2 SurTec Treated Aluminum Mesh – Cut after SurTec treatment \ (Figs. 18-21)
- [94]** Regular Mesh – Conductive antenna gasket
- [95]** In-Application Assembly – same as Alodine
- [96]** The process to coat the mesh with SurTec is as follows, this was performed at room temperature:
- [97]** Using 3-5% alkaline cleaner, soak sample for 5 minutes, dunk sample in deionized water;
- [98]** Using 2-7% alkaline etcher, soak sample for 1 minute, dunk sample in deionized water;
- [99]** Using 17% desmutting for aluminum, soak sample for 3 minutes, dunk sample in deionized water;
- [100]** Using 15% SurTec 650, soak sample for 4 minutes, dunk sample in deionized water;
- [101]** Allow to dry (ambient temperature) for 24 hours.
- [102]** See Figs. 10-25 for typical results, Applicant conductive gasket cut after SurTec treatment before testing and after 500 hours of salt fog exposure. Electrical resistance of the samples was measured at 1.67m Ω before testing and 2.85m Ω after 500 hours of salt fog exposure. Resistance value change compare to Alodine may be a result of extra gel thickness. Resistance may be measured before and after the salt fog testing by placement of the probes of a milliohmmeter at the points marked A and B in Fig. 12.
- [103]** Some of the environments which Applicant's novel gasket structures may use include antenna gasket (transmitting and/or receiving), for application to the surface of an aircraft, a fuel access door gasket (see US 9,303,447 incorporated herein by reference) that may also be conductive and used with the conversion coated metallic gasket set forth herein.
- [104]** In addition to the novel conversion coated metallic mesh gasket, Applicant's polyurethane gel, as set forth in the applications herein by reference, may include corrosion inhibitors that are compatible with polyurethane. These may include Hybricor 204, a pigment grade organic/inorganic zinc phosphate silicate corrosion inhibitor available from WPC Technologies, Milwaukee, Wisconsin, or Heucophos SAPP, a strontium aluminum polyphosphate corrosion inhibitor, pigment grade, available from Heubach GmbH, Langelsheim, Germany, or Huecos ZAPP, a zinc aluminum polyphosphate corrosion inhibitor available from Heubach GmbH. These three are known to be compatible with

polyurethane (see specification sheets) and are among the known non-chromate corrosion inhibitors used with aluminum.

[105] See Figs. 17-21 for typical results of the Av-DEC® conductive gasket cut after SurTec treatment before testing and after 500 hours of salt fog exposure. Electrical resistance of the samples was measured at 0.38mΩ before testing and 0.54 mΩ after 500 hours of salt fog exposure.

[106] See Figs. 22-25 (control, no conversion coating) for typical results of the Av-DEC® conductive antenna gasket after 500 hours of salt fog exposure.

[107] See Figs. 26-30 for typical results Av-DEC® conductive gasket cut after alodine treatment before testing and after 500 hours of salt fog exposure. Electrical resistance of the samples was measured at 0.92mΩ before testing and 1.32 mΩ after 500 hours of salt fog exposure.

[108] See Figs. 31-35 for typical results of the Av-DEC® conductive gasket cut before alodine treatment before testing and after 500 hours of salt fog exposure. Electrical resistance of the samples was measured at 12.53mΩ before testing and 14.92 mΩ after 500 hours of salt fog exposure. Resistance value change could be attributed to extra gel thickness.

[109] In one embodiment of Applicant’s invention, an aluminum mesh is coated with one of the conversion coatings set forth herein and the gel is mixed with one of the corrosion inhibitors set forth herein. In one embodiment, the mixing of the gel and the referenced corrosion inhibitors may be according to Publication No. US-2016/0017143 (published 1/21/2016), which describes the use of known “off-the-shelf” non-chromated corrosion inhibitors in tacky polyurethane gels. In another embodiment of Applicant’s present invention, the non-chromated corrosion inhibitors are used in the polyurethane gel along with an uncoated or conversion coated metallic mesh, such as aluminum mesh gasket, wherein the mesh is not treated with a conversion coating. One such mesh is 5056Al 18 mesh available from Cleveland Wire or AvDec®.

500 Hour Salt Fog Corrosion and Resistance Summary

	Corrosion (qualitative)		Resistance Delta (measured)
Control (untreated)	Figs. 22-25		
SurTec			
Pre-cut	Figs. 13-16		1.18mΩ ¹
Post-cut	Figs. 18-21		.16 mΩ

Alodine			
Pre-cut	Figs. 32-35		2.39 mΩ ¹
Post-cut	Figs. 27-30		.40 mΩ

¹ Resistance value change could be attributed to extra gel thickness

[110] A copper alloy mesh was also tested with the SurTec conversion coating, applied as set forth with the aluminum alloy mesh. The results were good for both resistance and corrosion prevention, though not quite as good in corrosion prevention as the coated aluminum mesh. The resistance prior to salt fog was .48 milliohms and after testing was 1.33 milliohms, with a resistance Delta of .85 milliohms. A nickel mesh was tested with similar results.

[111] These tests show that conversion coatings help prevent corrosion of the aircraft parts and still provide a low resistance. Moreover, from a careful examination of the mesh itself, it appears that the mesh of the control has begun to be corroded slightly after 500 hours of salt fog, which was not observed on the coated meshes.

[112] Although the invention has been described in connection with the preferred embodiment, it is not intended to limit the invention's particular form set forth, but on the contrary, it is intended to cover such alterations, modifications, and equivalences that may be included in the spirit and scope of the invention as defined by the appended claims.

CLAIMS

1. A gasket for use between aircraft parts under compression, the gasket comprising:
a body comprising an elastomeric polymer; and
a metal skeleton encapsulated by the body of the gasket;
wherein the metal skeleton includes a conversion coating.
2. The gasket of Claim 1, wherein the body is a tacky polyurethane gel and wherein the metal skeleton is an aluminum or aluminum alloy mesh and wherein the resistance of the coated aluminum or aluminum alloy mesh is less than about 2.5 milliohms.
3. The gasket of Claim 1, wherein conversion coating is coated between about 100 – 250 mg/dm².
4. The gasket of Claim 1, wherein the elastomeric polymer is a polyurethane gel.
5. The gasket of Claim 1, wherein the body includes conductive particles or fibers.
6. The gasket of Claim 1, including a second skeleton.
7. The gasket of Claim 1, wherein the second skeleton is a metallic mesh.
8. The gasket of Claim 1, wherein the body is comprised of a polyurea polymer.
9. The gasket of Claim 1, wherein the body is comprised of a tacky, deformable, flowable gel.
10. The gasket of Claim 1, wherein the metal skeleton has a perimeter and wherein , when under compression, the body extends beyond the perimeter of the skeleton.
11. The gasket of Claim 10, wherein the perimeter includes a cure in place injectable polymer.
12. The gasket of Claim 1, wherein the resistance of the skeleton is less than about 2.5mΩ.
13. The gasket of Claim 1, wherein conversion layer comprises a chromium.
14. The gasket of Claim 13, wherein the chromium is part of a chromate.
15. The gasket of Claim 14, wherein the chromate includes trivalent chromium.
16. The gasket of Claim 1, wherein the conversion coating includes a hexafluorozirconate.
17. The gasket of Claim 1, wherein the gel includes corrosion inhibitors.
18. A method of producing a corrosion resistance assembly of aircraft parts comprising:
contacting an exterior of a skeleton with a composition comprising a reactive composition to obtain a conversion coating on a top surface coat on the skeleton surface and assembling the skeleton comprising said top surface coat into an aircraft gasket having an elastomeric body and placing the gasket under compression between two parts of an aircraft.
19. The method of Claim 18, wherein the skeleton is die cut before contacting.

20. The method of Claim 18, wherein before the placing step and after the contacting step, the skeleton is die cut into a preselected shape.
21. The method of Claim 18, wherein the reactive composition contains trivalent chromium.
22. The method of Claim 18, wherein the reactive composition contains hexavalent chromium.
23. The method of Claim 18, wherein the reactive composition contains chromium, either a trivalent or hexavalent chromium, and elastomeric body is a tacky gel body including a polyurethane or polyurea two component sealant.
24. An assembly of aircraft parts comprising:
a first aluminum or aluminum alloy part having a first surface;
a second aluminum or aluminum alloy part having a second surface;
a multiplicity of fasteners for engaging the two aluminum or aluminum alloy parts;
a gasket comprising a body comprising an elastomeric polymer; and
a metal skeleton encapsulated by the body of the gasket;
wherein the metal skeleton includes a conversion coating.
25. The assembly of Claim 24, wherein the two parts comprise an aircraft antenna and an aircraft skin.
26. The assembly of Claim 24, wherein the two parts comprise an aircraft fuel door surround and an aircraft fuel door.

Sheet 1/18

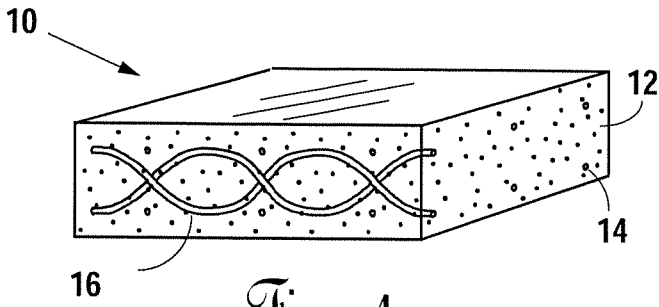

Fig. 1

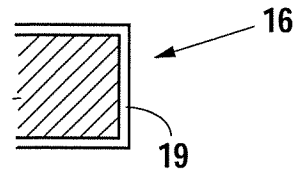

Fig. 2

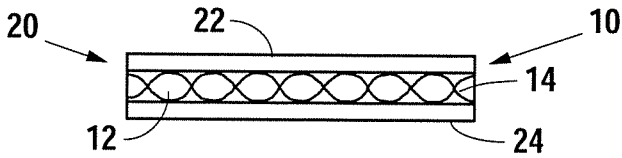

Fig. 3

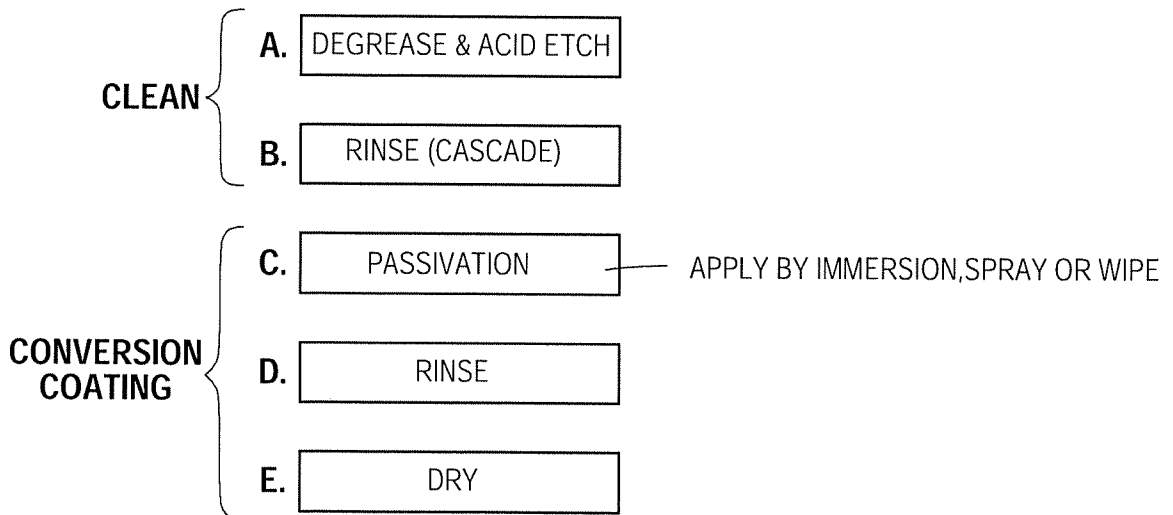

Fig. 4

GENERAL PASSIVATION
PROCESS

Sheet 2/18

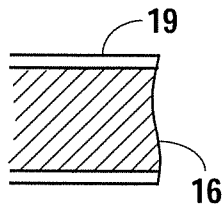

Fig. 5

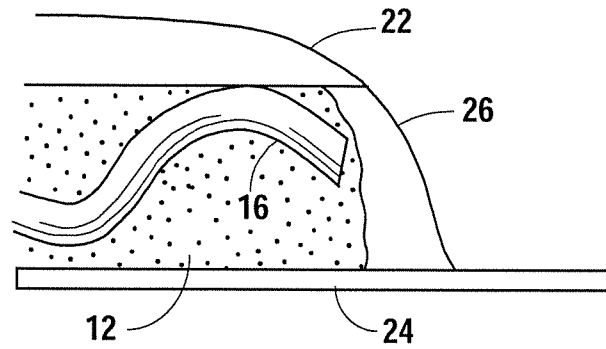

Fig. 6

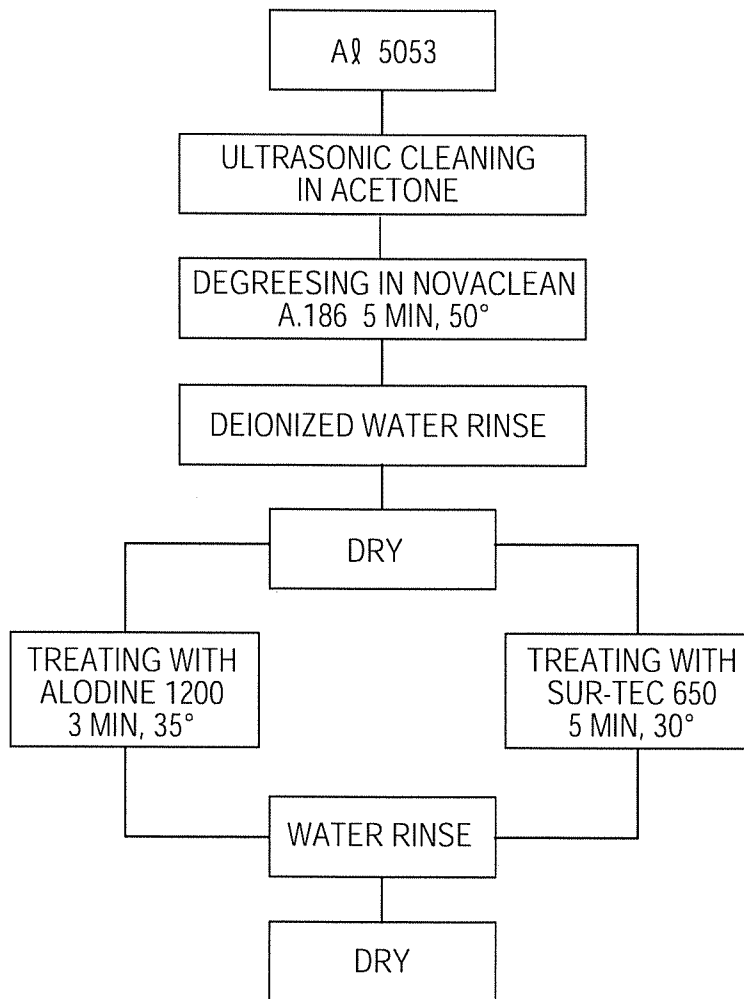

Fig. 7

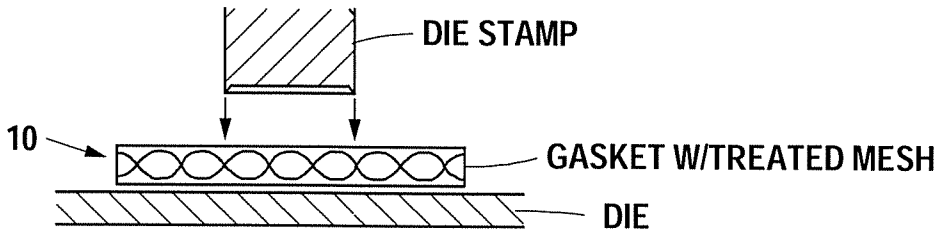

Fig. 8

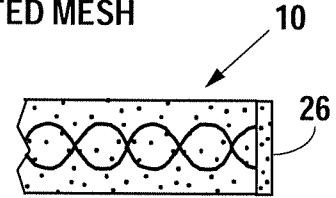

Fig. 8A

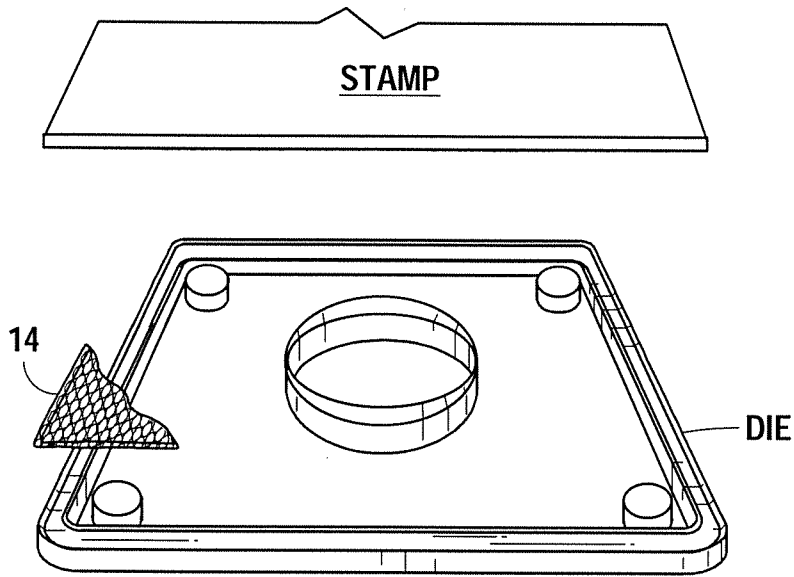

Fig. 9

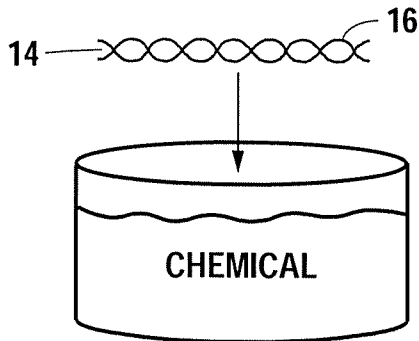

Fig. 9A

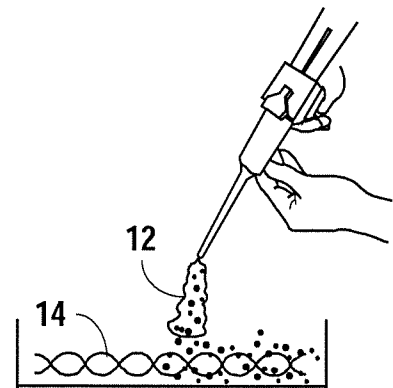

Fig. 9B

Sheet 4/18

RESULTS

See Figures 10-25 for typical results of the Av-DEC® conductive gasket cut before SurTec treatment before testing and after 500 hours of salt fog exposure. Electrical resistance of the samples was measured at 1.67mΩ before testing and 2.85mΩ after 500 hours of salt fog exposure. Resistance value change could be attributed to extra gel thickness.

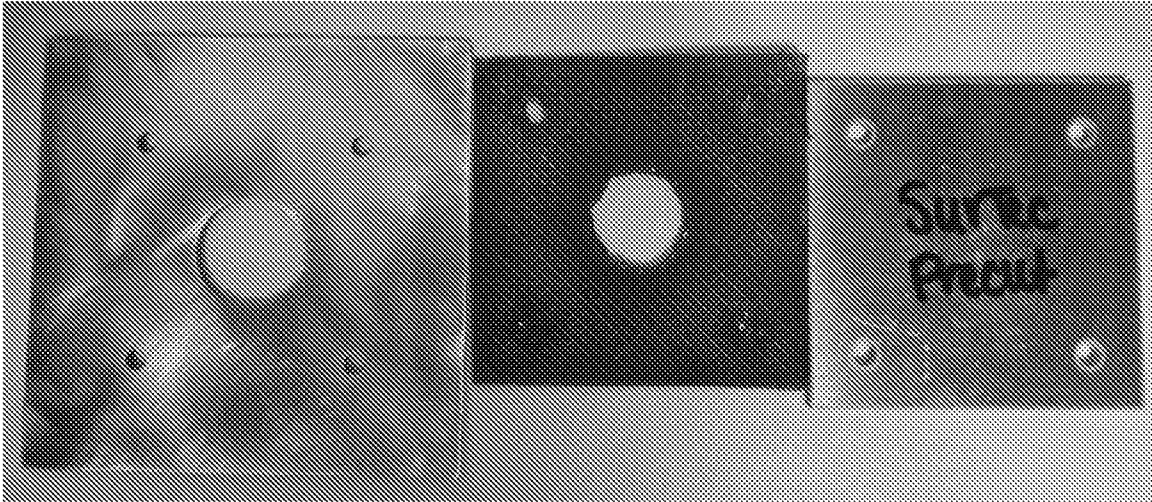

Figure 10. Typical test assembly prior to assembly and exposure

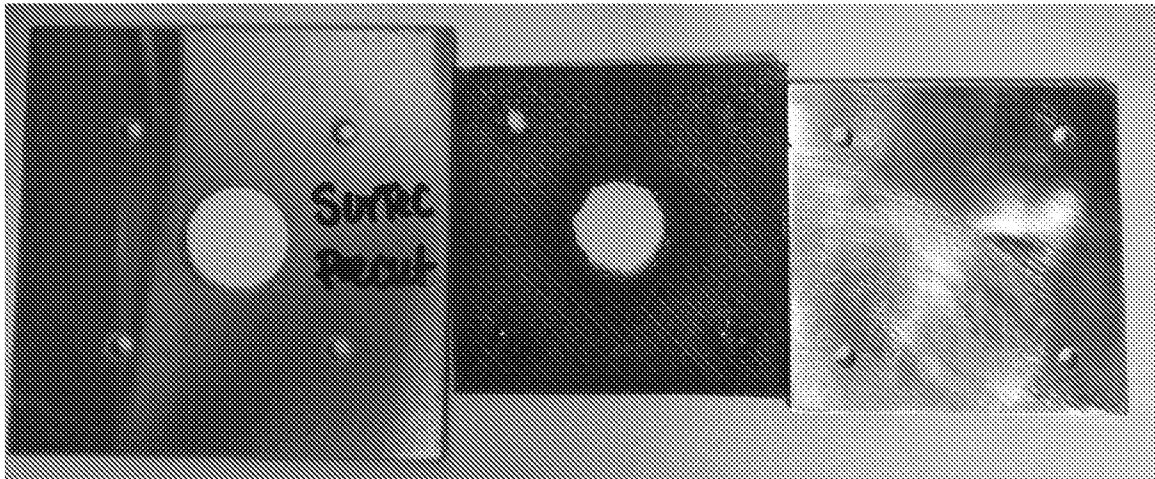

Figure 11. Typical test assembly prior to assembly and exposure (opposite side)

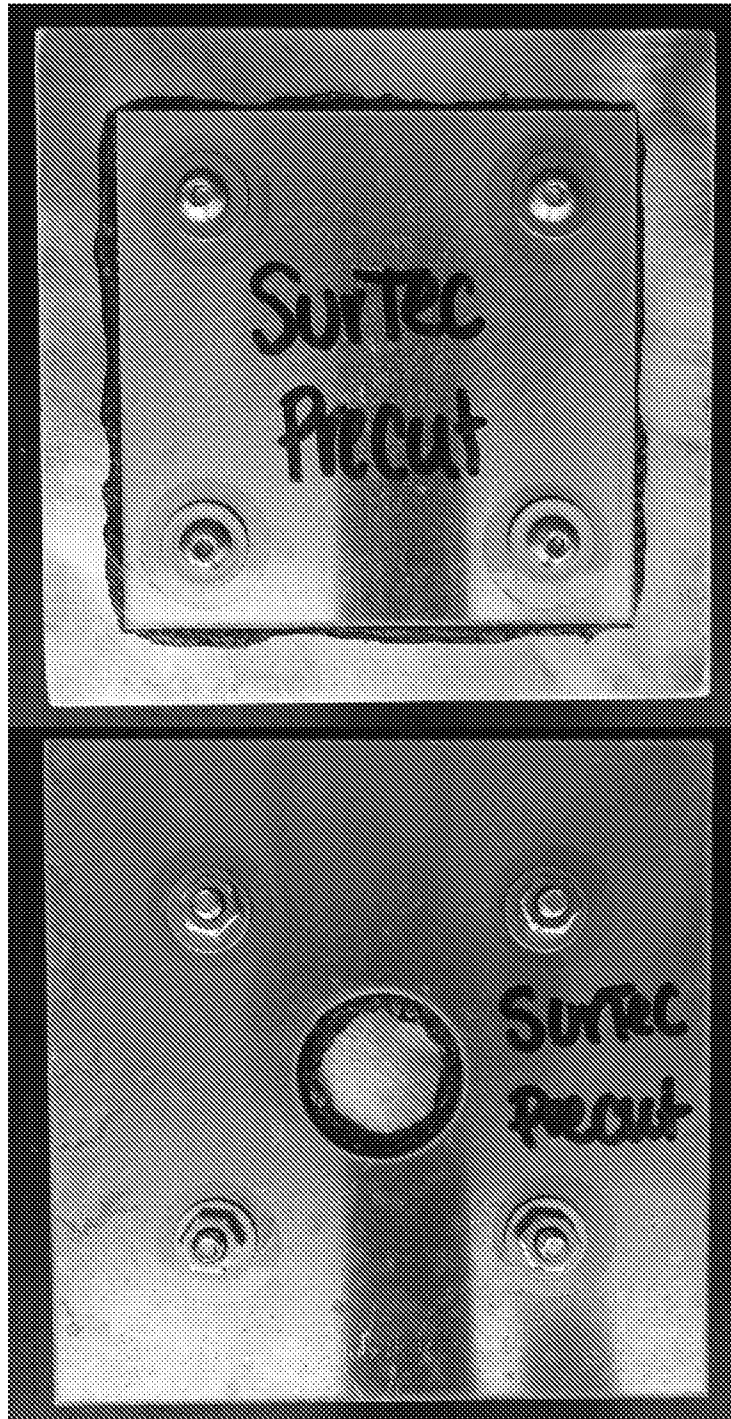

Figure 12. Typical test assembly prior to exposure

Sheet 6/18

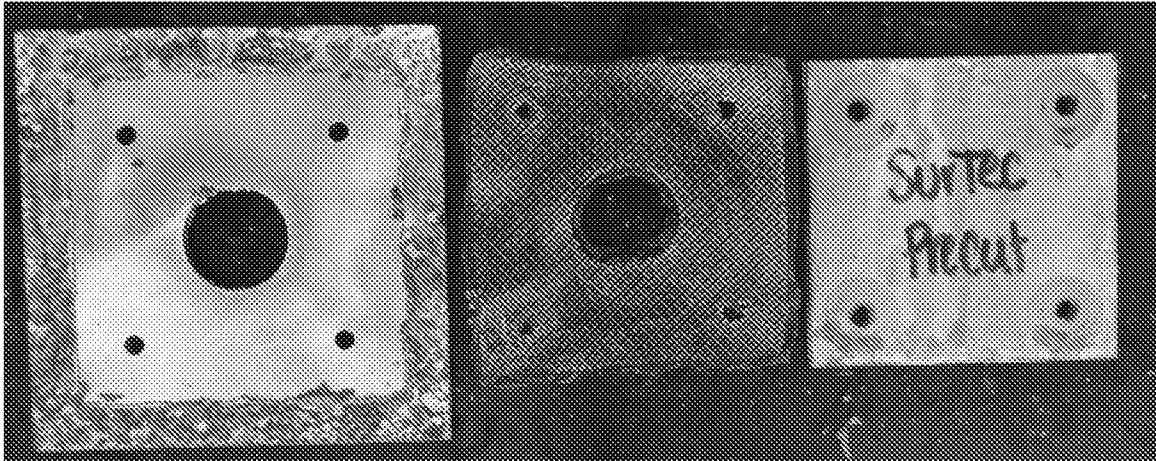

Figure 13. Disassembled Test Assembly after 500 hours of exposure – no corrosion present on area protected by gasket

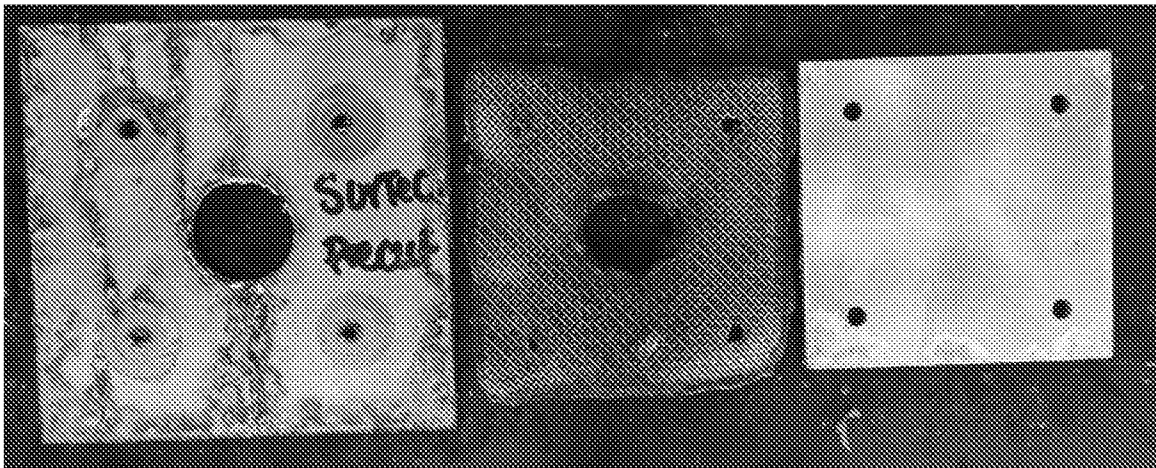

Figure 14. Disassembled Test Assembly after 500 hours of exposure – no corrosion present on area protected by gasket (opposite side)

Sheet 7/18

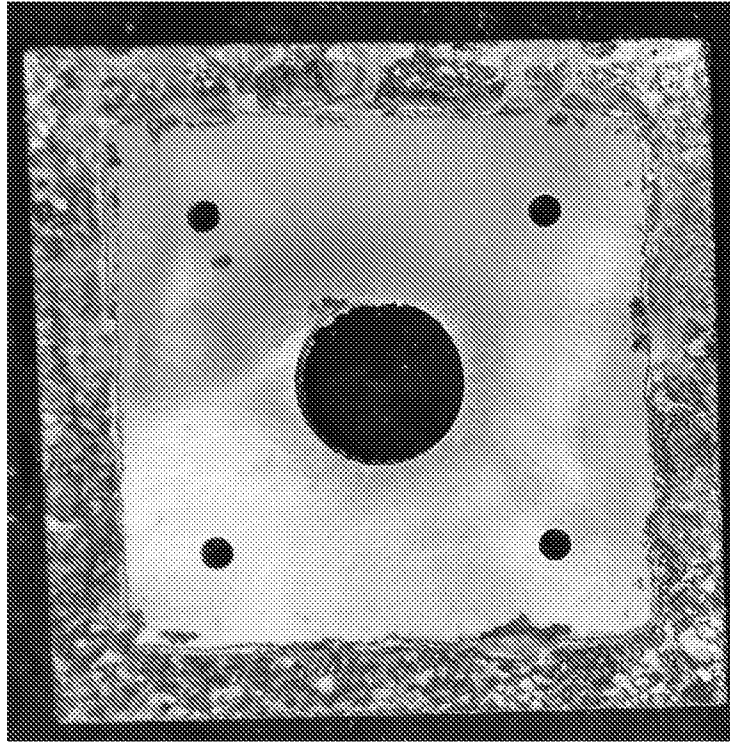

Figure 15. Aircraft Side after 500 hours of exposure – no corrosion present on area protected by gasket, slight discolorations around center hole noted

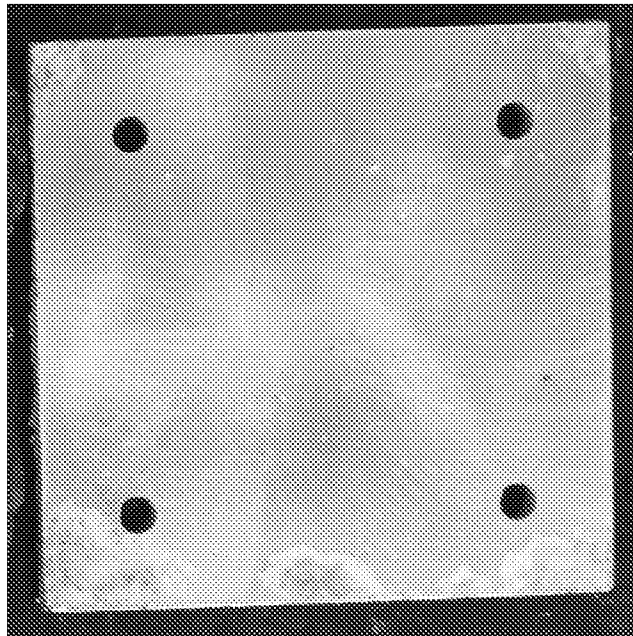

Figure 16. Antenna Base Side after 500 hours of exposure – no corrosion present on area protected by gasket, slight discolorations around perimeter noted

Sheet 8/18

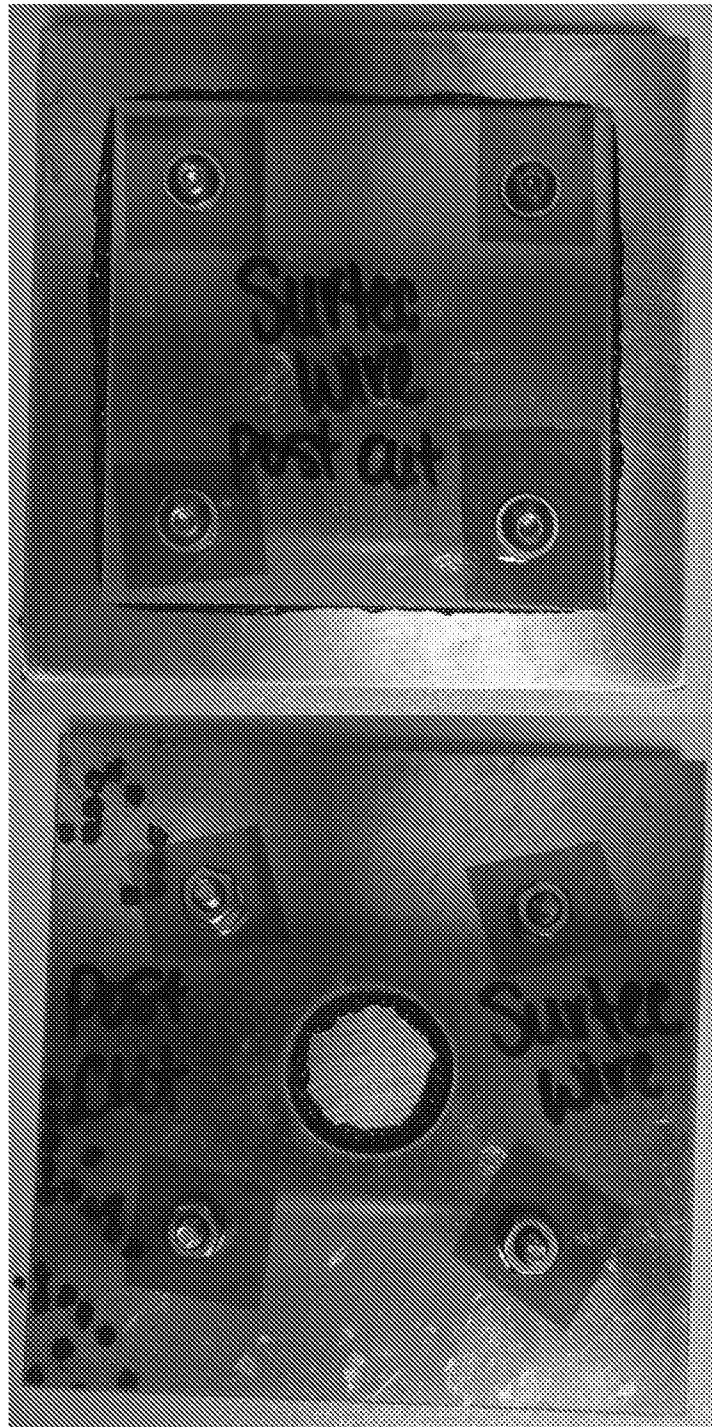

Figure 17. Typical test assembly prior to exposure

Sheet 9/18

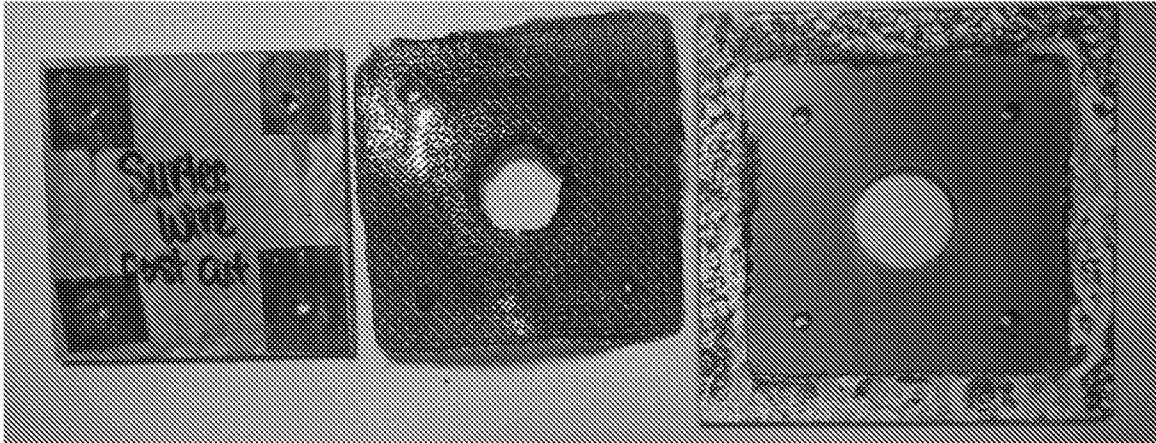

Figure 18. Disassembled Test Assembly after 500 hours of exposure – no corrosion present on area protected by gasket

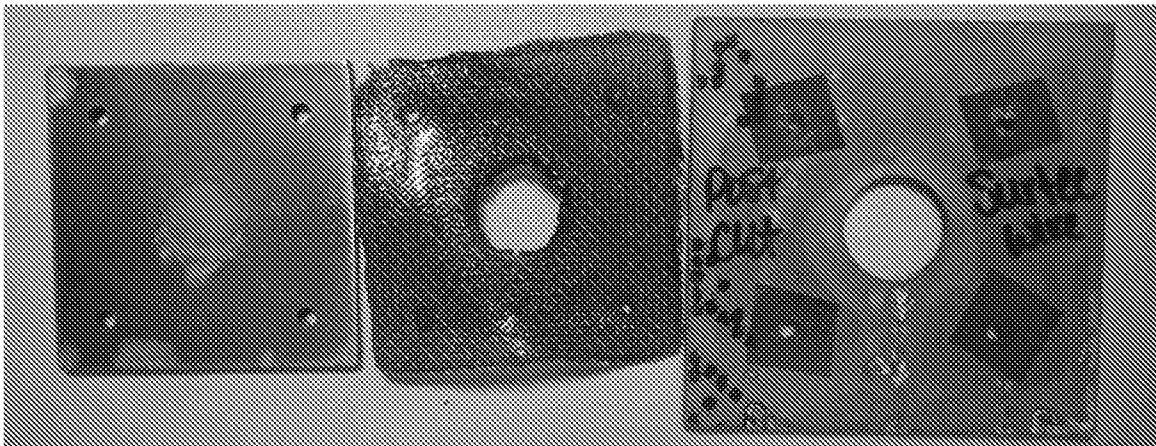

Figure 19. Disassembled Test Assembly after 500 hours of exposure – no corrosion present on area protected by gasket (opposite side)

Sheet 10/18

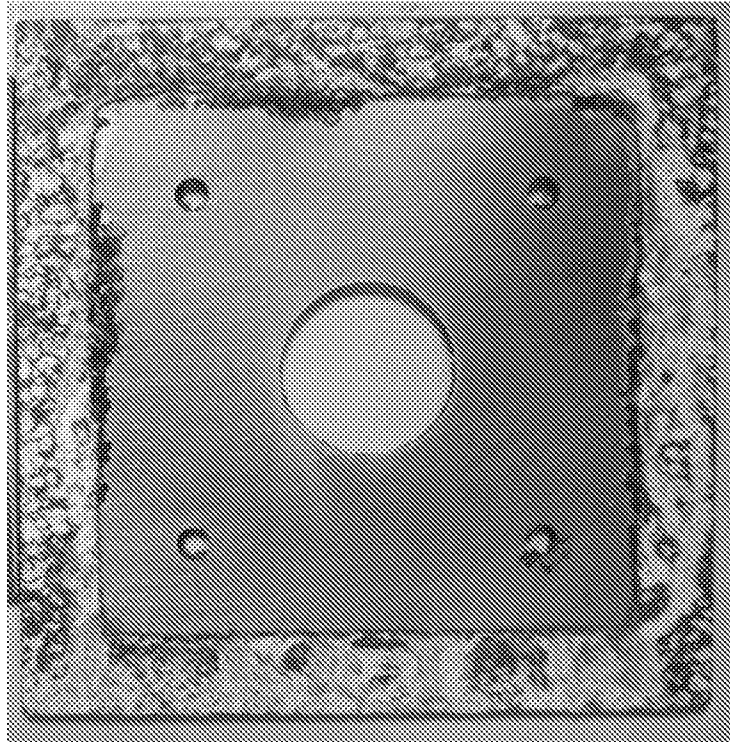

Figure 20. Aircraft Side after 500 hours of exposure – no corrosion present on area protected by gasket, discoloration around lower right hole noted

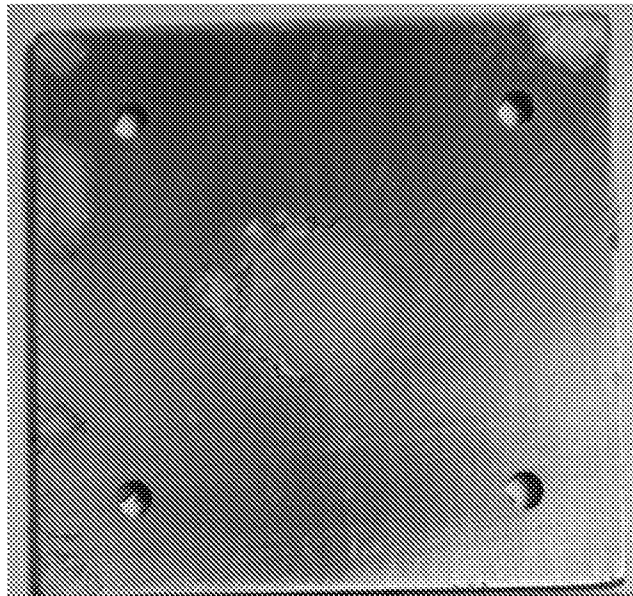

Figure 21. Antenna Base Side after 500 hours of exposure – no corrosion present on area protected by gasket, discolorations around perimeter noted

Sheet 11/18

See Figures 22-25 for typical results of the Av-DEC® conductive antenna gasket after 500 hours of salt fog exposure.

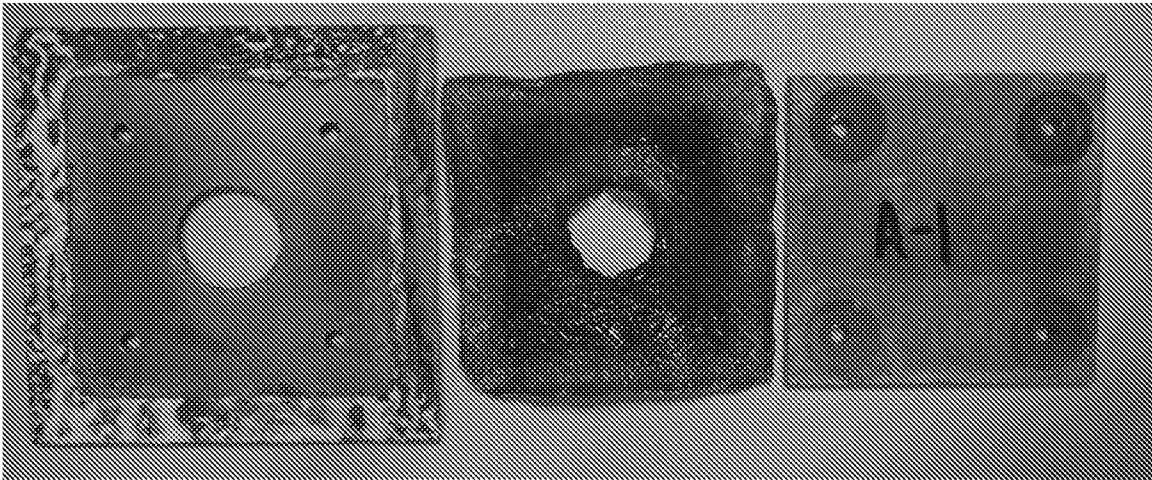

Figure 22. Disassembled Test Assembly after 500 hours of exposure – no corrosion present on area protected by gasket

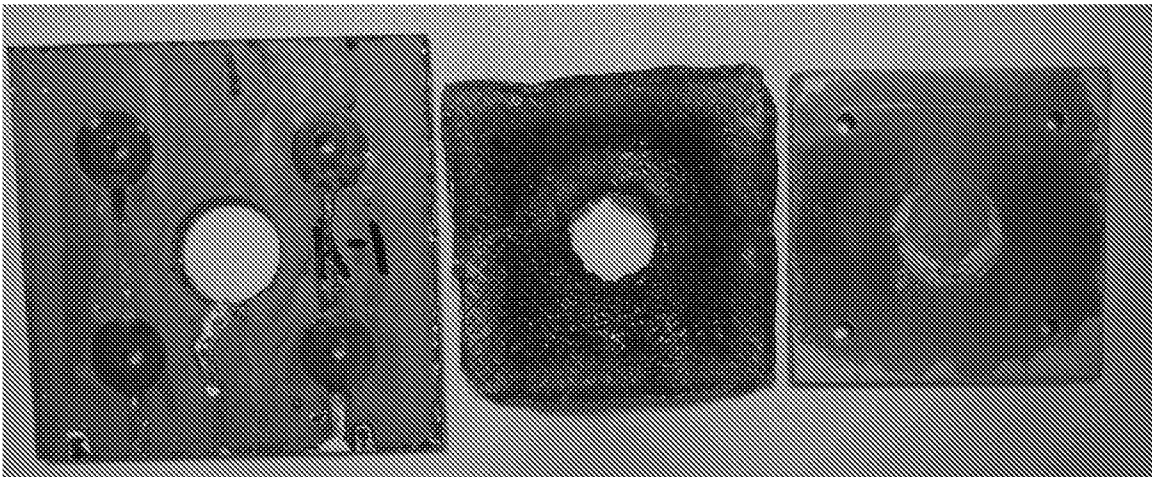

Figure 23. Disassembled Test Assembly after 500 hours of exposure – slight corrosion present on area protected by gasket

Sheet 12/18

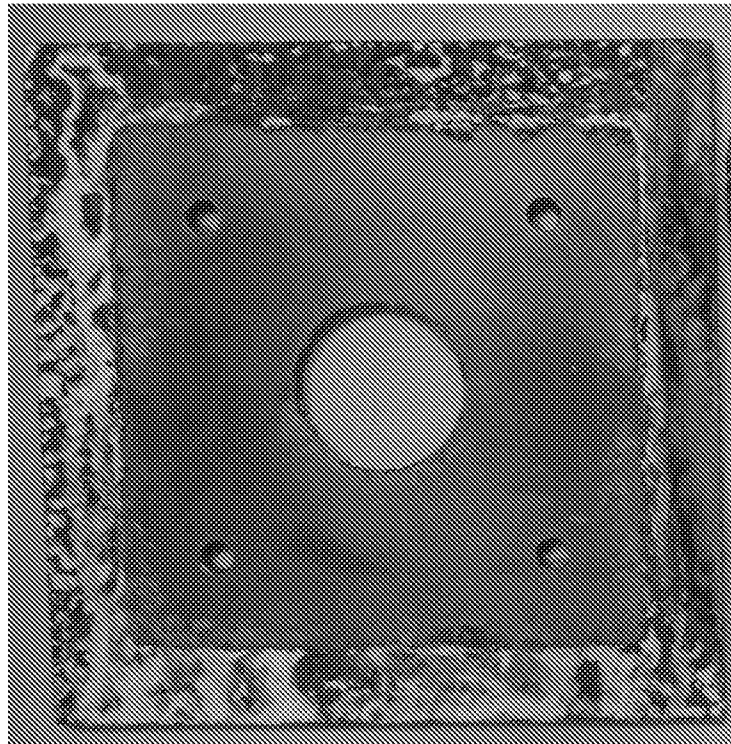

Figure 24. Aircraft Side after 500 hours of exposure – no corrosion present on area protected by gasket

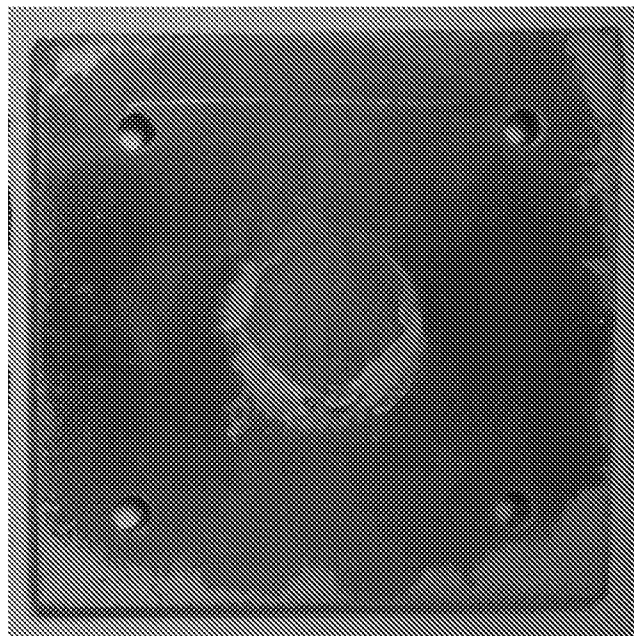

Figure 25. Antenna Base Side after 500 hours of exposure – slight corrosion present on area protected by gasket, discolorations around perimeter noted

Sheet 13/18

RESULTS

See Figures 26-30 for typical results Av-DEC® conductive gasket cut after alodine treatment before testing and after 500 hours of salt fog exposure. Electrical resistance of the samples was measured at 0.92mΩ before testing and 1.32 mΩ after 500 hours of salt fog exposure.

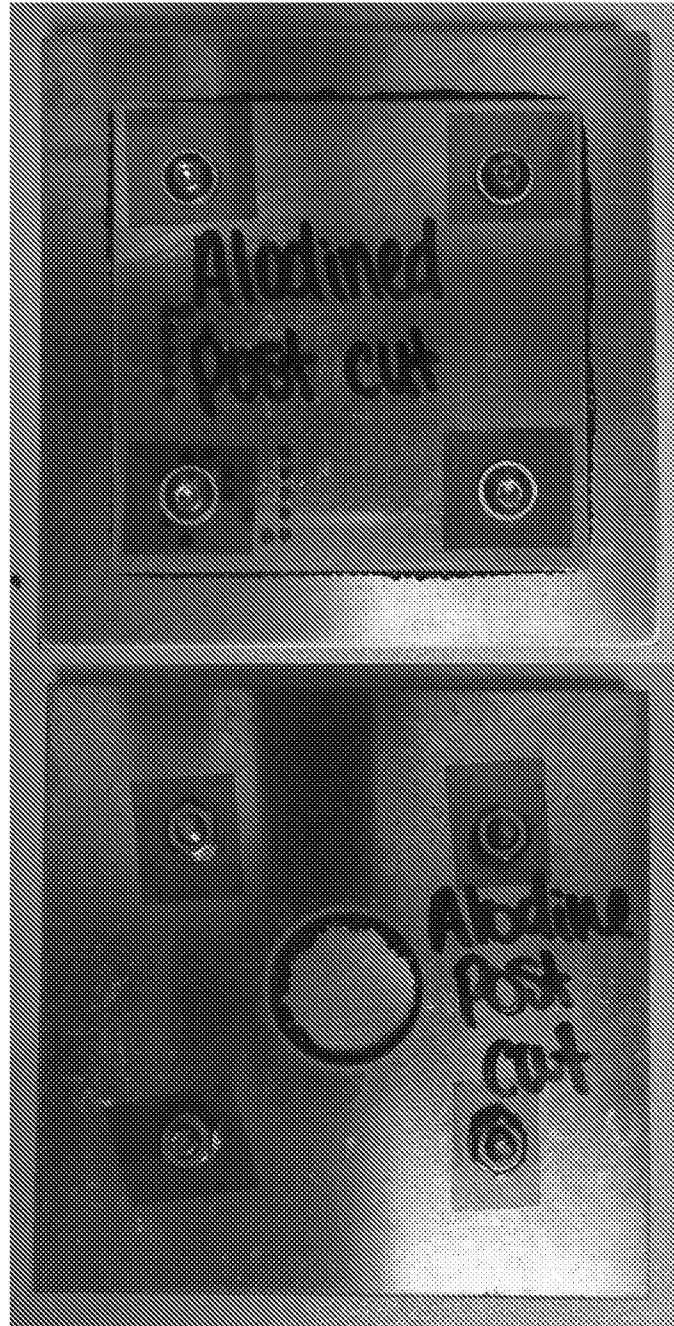

Figure 26. Typical test assembly prior to exposure

Sheet 14/18

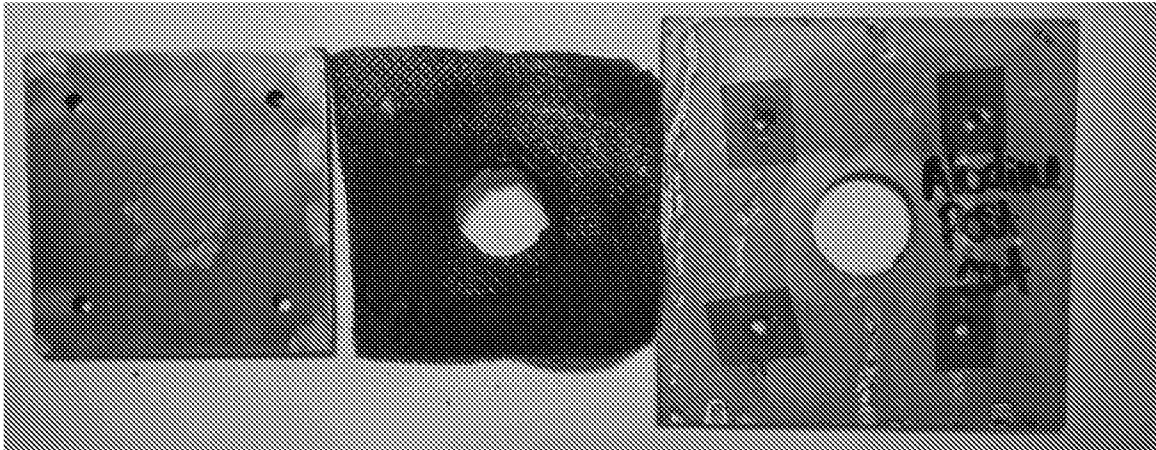

Figure 27. Disassembled Test Assembly after 500 hours of exposure – slight corrosion present on area protected by gasket

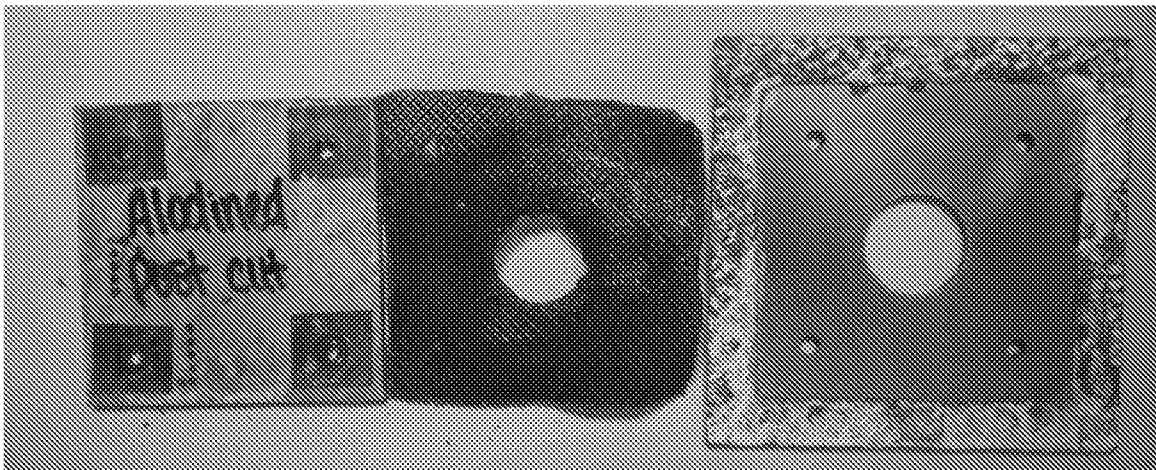

Figure 28. Disassembled Test Assembly after 500 hours of exposure – no corrosion present on area protected by gasket

Sheet 15/18

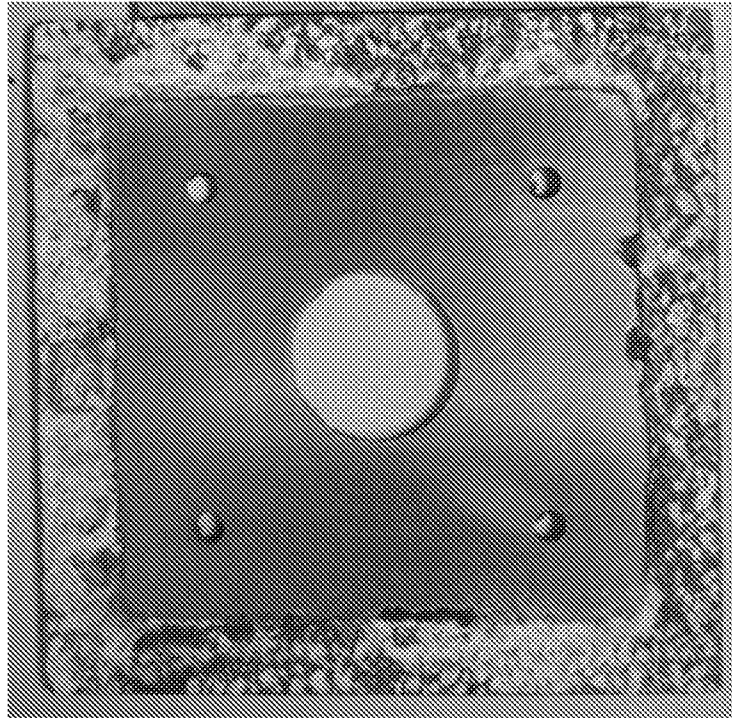

Figure 29. Aircraft Side after 500 hours of exposure – no corrosion present on area protected by gasket

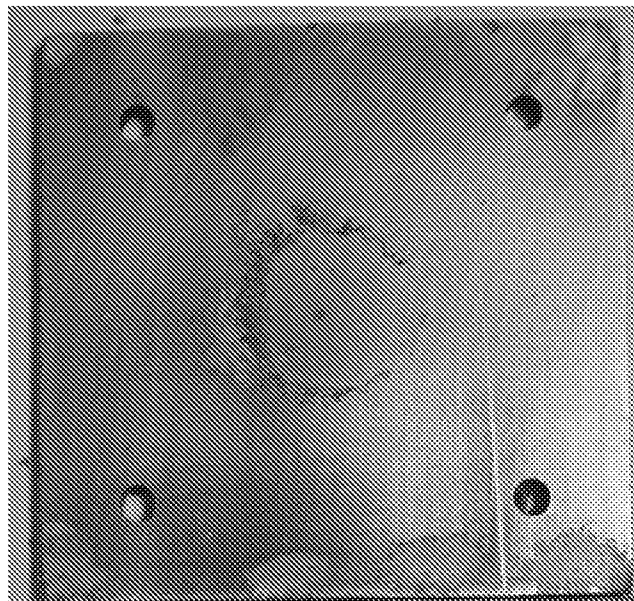

Figure 30. Antenna Base Side after 500 hours of exposure – slight corrosion present on area protected by gasket, discolorations around perimeter noted

Sheet 16/18

See Figures 31-35 for typical results of the Av-DEC® conductive gasket cut before alodine treatment before testing and after 500 hours of salt fog exposure. Electrical resistance of the samples was measured at 12.53mΩ before testing and 14.92 mΩ after 500 hours of salt fog exposure. Resistance value change could be attributed to extra gel thickness.

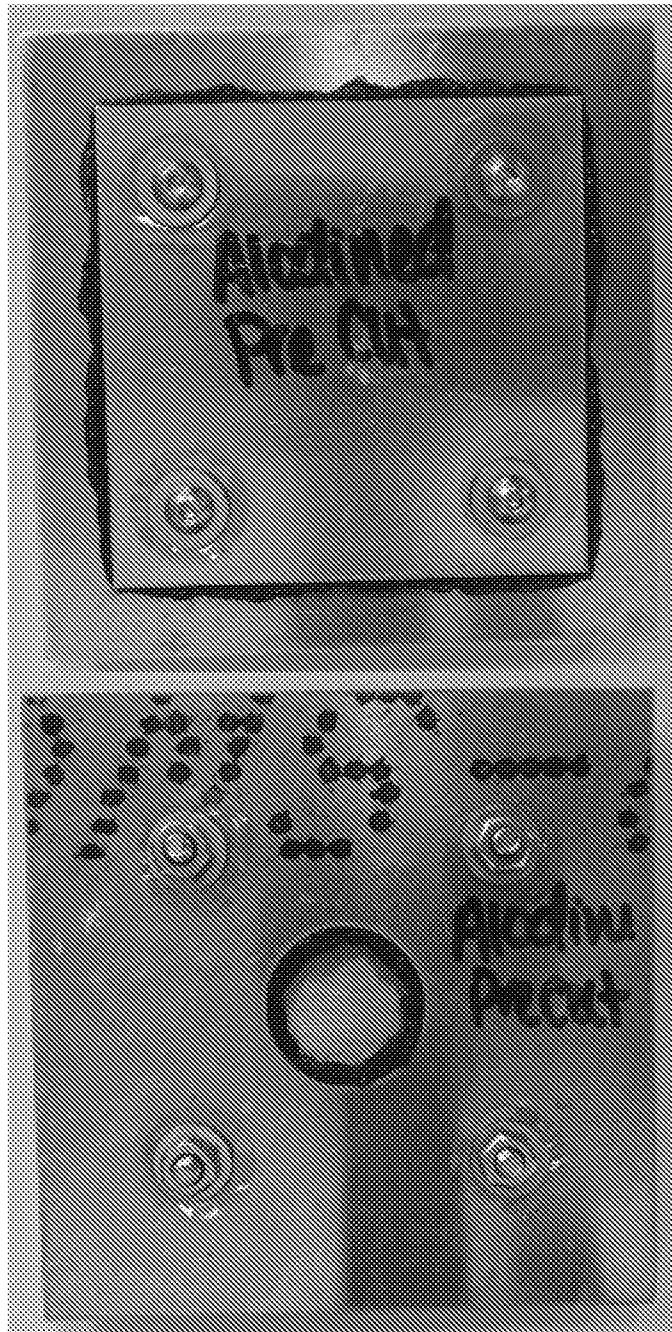

Figure 31. Typical test assembly prior to exposure

Sheet 17/18

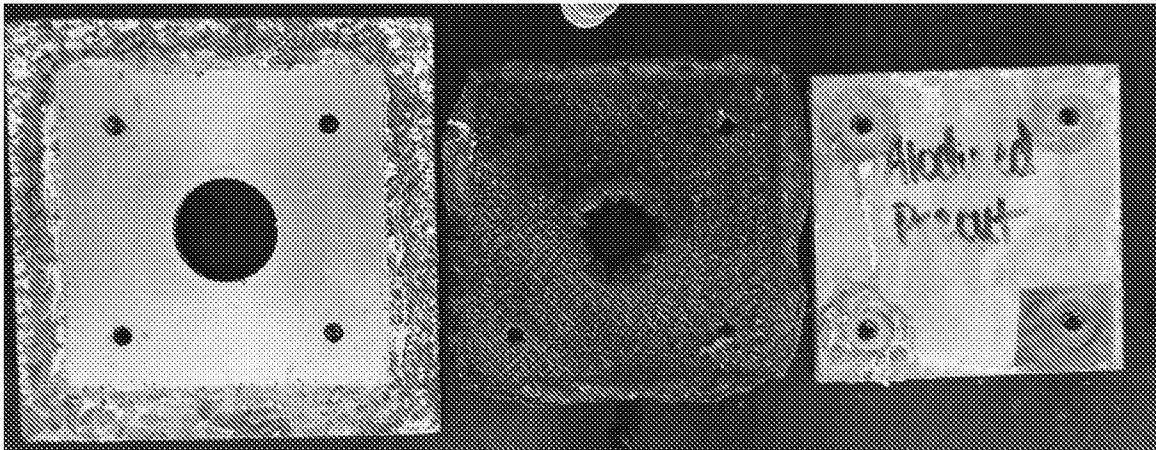

Figure 32. Disassembled Test Assembly after 500 hours of exposure – no corrosion present on area protected by gasket



Figure 33. Disassembled Test Assembly after 500 hours of exposure – no corrosion present on area protected by gasket

Sheet 18/18

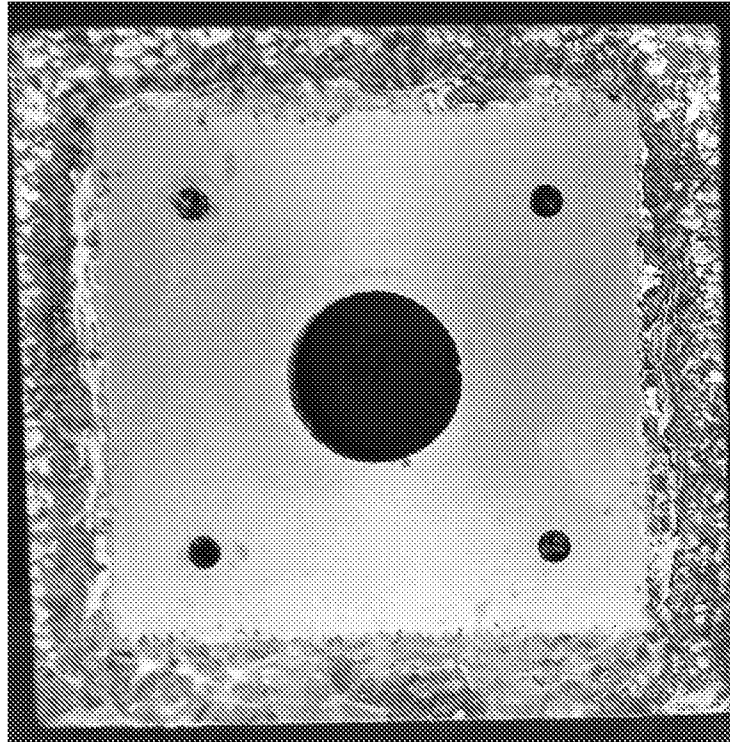

Figure 34. Aircraft Side after 500 hours of exposure – no corrosion present on area protected by gasket, discolorations indicate incomplete removal of product

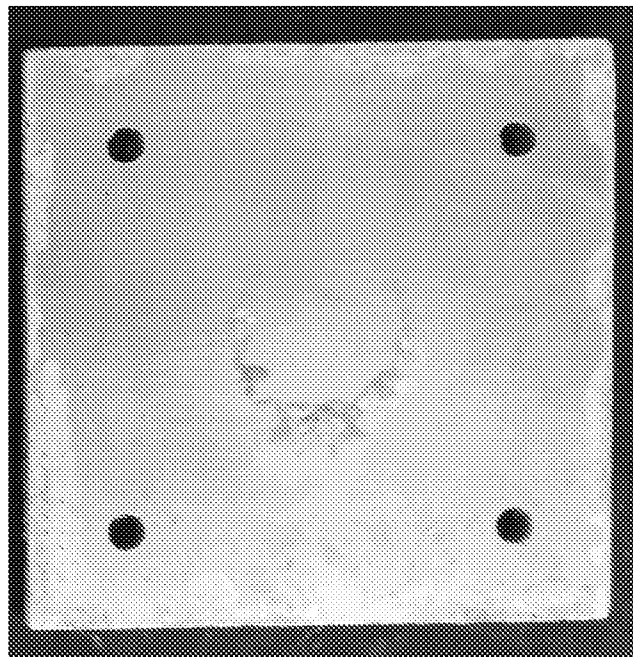

Figure 35. Antenna Base Side after 500 hours of exposure – no corrosion present on area protected by gasket, discolorations around perimeter noted

INTERNATIONAL SEARCH REPORT

International application No.

PCT/US16/26760

A. CLASSIFICATION OF SUBJECT MATTER

IPC(8) - F16J 15/06; B32B 27/40; E06B 7/22 (2016.01)

CPC - F16J 15/126; B32B 27/40; E06B 7/22

According to International Patent Classification (IPC) or to both national classification and IPC

B. FIELDS SEARCHED

Minimum documentation searched (classification system followed by classification symbols)

IPC(8) : F16J 15/00, 15/06, 15/12; E06B 7/16, 7/22, 7/23, 7/232; B32B 27/40 (2016.01)

CPC: B32B 5/18, 27/04, 27/40; Y10S 277/00, 277/935, 277/939, 277/944; F16J 15/00, 15/06, 15/121, 15/126, 15/123; E06B 7/16, 7/22

Documentation searched other than minimum documentation to the extent that such documents are included in the fields searched

Electronic data base consulted during the international search (name of data base and, where practicable, search terms used)

PatSeer (US, EP, WO, JP, DE, GB, CN, FR, KR, ES, AU, IN, CA, Other Countries (INPADOC), RU, AT, CH, TH, BR, PH); Google Patent, Google Scholar, IEEE, Total Patent, EBSCO; Keywords: gasket, seal, aircraft, airplane, conversion coating, metal, aluminum, skeleton, chromium, trivalent, hexavalent, elastomeric, polymer, gel

C. DOCUMENTS CONSIDERED TO BE RELEVANT

Category*	Citation of document, with indication, where appropriate, of the relevant passages	Relevant to claim No.
Y --- A	US 2003/0047885 A1 (BUSBY, J et al.) March 13, 2003; figure 9, paragraphs [0024], [0039] [0042], [0044], [0050]	1-17, 20, & 24-26 --- 23
Y	US 2014/0319276 A1 (MITSUBISHI AIRCRAFT CORPORATION) October 30, 2014; figures 1, 2a, paragraphs [0038], [0048], [0053], [0063], [0066], [0068], [0073], [0076], [0078], [0079], [0089], [0090], [0092]	1-22 & 24-26
Y	US 2014/0120365 A1 (MIYOSHI, T et al.) May 01, 2014; paragraphs [0040], [0041], [0090], table 2	3
Y	US 5,294,270 A (FENICAL, G) March 15, 1994; figure 5, column 4, lines 26-41	6 & 7
Y	US 2014/0326830 A1 (AVIATION DEVICES & ELECTRONIC COMPONENTS, L.L.C.) November 06, 2014; figures 4a, 5, 25, paragraphs [0017], [0042], [0046], [0049], [0050], [0078], [0083]	10 & 11
Y --- A	US 6,521,029 B1 (MATZDORF, C et al.) February 18, 2003; column 2, lines 21-24, column 3, lines 57-60, line 64 to column 4, line 2, lines 32-41	15, 16, & 21 --- 23
Y	EP 0 324 255 A2 (RAYCHEM CORPORATION) July 19, 1989; abstract, page 2, lines 51-53, page 3, lines 9-17	17
Y --- A	US 4,103,913 A (MCDOWELL, D) August 01, 1978; title, column 2, lines 63-65, column 3, lines 3-61, claim 1	18-22 --- 23

 Further documents are listed in the continuation of Box C. See patent family annex.

* Special categories of cited documents:

"A" document defining the general state of the art which is not considered to be of particular relevance

"T" later document published after the international filing date or priority date and not in conflict with the application but cited to understand the principle or theory underlying the invention

"E" earlier application or patent but published on or after the international filing date

"X" document of particular relevance; the claimed invention cannot be considered novel or cannot be considered to involve an inventive step when the document is taken alone

"L" document which may throw doubts on priority claim(s) or which is cited to establish the publication date of another citation or other special reason (as specified)

"Y" document of particular relevance; the claimed invention cannot be considered to involve an inventive step when the document is combined with one or more other such documents, such combination being obvious to a person skilled in the art

"O" document referring to an oral disclosure, use, exhibition or other means

"&" document member of the same patent family

"P" document published prior to the international filing date but later than the priority date claimed

Date of the actual completion of the international search

Date of mailing of the international search report

07 June 2016 (07.06.2016)

17 JUL 2016

Name and mailing address of the ISA/

Mail Stop PCT, Attn: ISA/US, Commissioner for Patents

P.O. Box 1450, Alexandria, Virginia 22313-1450

Facsimile No. 571-273-8300

Authorized officer

Shane Thomas

PCT Helpdesk: 571-272-4300

PCT OSP: 571-272-7774

INTERNATIONAL SEARCH REPORT

International application No.

PCT/US16/26760

C (Continuation). DOCUMENTS CONSIDERED TO BE RELEVANT		
Category*	Citation of document, with indication, where appropriate, of the relevant passages	Relevant to claim No.
Y	US 2,957,784 A (SCHIEFELBEIN, M) October 25, 1960; column 4, line 72 to column 5, line 1	22
Y	US 2015/0069722 A1 (AVIATION DEVICES & ELECTRONIC COMPONENTS, LLC) March 12, 2015; figure 6, paragraphs [0041], [0042]	26