

Jan. 25, 1944.

J. H. BREWER ET AL

2,339,908

DISPENSING APPARATUS

Filed Oct. 10, 1942

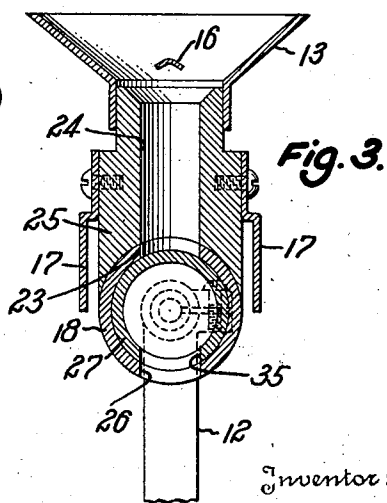
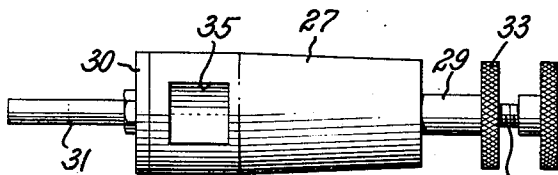
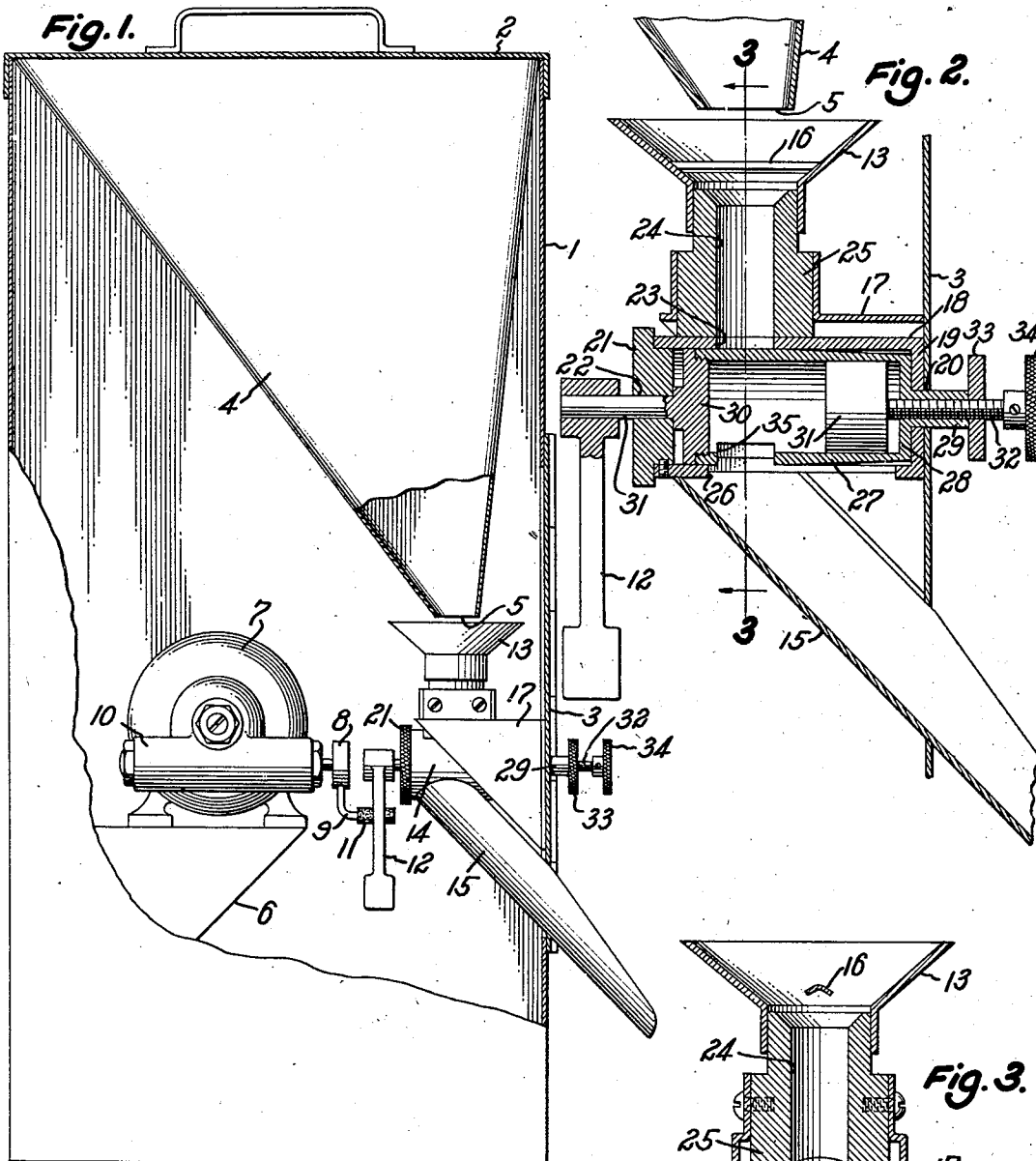

Fig. 4.

Fig. 3.

Inventor:
John H. Brewer +
Harry E. Taylor
By Pierce & Scheffler
their Attorneys.

UNITED STATES PATENT OFFICE

2,339,908

DISPENSING APPARATUS

John H. Brewer and Harry Ellsworth Taylor,
Baltimore, Md., assignors to Hynson, Westcott
& Dunning, Incorporated, a corporation of
Maryland

Application October 10, 1942, Serial No. 461,588

4 Claims. (Cl. 221-107)

An object of the present invention is to provide apparatus for delivering measured quantities of free flowing powdered or granular materials, such as sugar, salt and the like, at regular predetermined intervals. In experimenting with apparatus designed for this purpose a variety of difficulties have been encountered all of which have been eliminated in our apparatus which includes the following features:

(1) A hopper for the material which presents no sharp angles or corners at which the material may lodge and impede its free flow;

(2) A funnel which receives the material from the hopper and delivers it to the measuring unit, said funnel being provided with a member which serves to prevent packing and irregularity of flow of the material;

(3) A measuring unit having means for adjusting the size of the pocket which measures the charge of material to be delivered at each operation;

(4) A measuring unit which is cylindrical in shape and rotates in a cylindrical housing and which is tapered to prevent binding and insure the continued free rotation thereof, and

(5) Means for rotating the measuring unit at uniform intervals but at a non-uniform rate in each revolution so as to discharge a measured quantity of the material at regular intervals and at the same time facilitate the charging and discharging of the measuring unit.

The foregoing and other features of the apparatus will be described more fully in the following detailed description of an embodiment of the invention.

Referring to the accompanying drawing:

Fig. 1 is a side elevation of the dispensing unit with a portion of the side wall of the housing broken away to reveal the mechanism inside.

Fig. 2 is an enlarged vertical section of the dispensing mechanism.

Fig. 3 is a vertical section on the line 3-3 of Fig. 2, and

Fig. 4 is a plan view of the measuring unit.

The complete apparatus illustrated consists of a rectangular housing 1, suitably made of sheet iron and provided with a cover 2 and a hinged door 3. Within the upper portion of the housing 3 is the hopper 4 of suitable capacity which may be filled by removing the cover 3. The walls of hopper 4 converge to the circular discharge opening 5 and as stated is made free of sharp corners or angles by joining four flat side walls by rounded corners.

Within the housing 1 is a bracket 6 which carries

the motor 7. Motor 7 is of a known type capable of maintaining a predetermined constant speed which is determined by adjustment of a control knob (not shown) preferably located on the outside of the side wall of the housing. The motor drives the wheel 8 carrying the finger 9 through the speed reducing gearing 10. Finger 9 suitably is provided with a rubber sleeve 11 where it engages the weighted arm 12.

The measuring unit device which receives the material from the hopper 4, segregates a measured quantity of it and discharges it, is mounted on the door 3 where it is accessible by simply swinging the door to open position. This device consists of the broad-mouthed funnel 13, the charge measuring unit 14 and the discharge spout 15 which latter extends through the door 3. The upper end of the spout 15 is flared to embrace the lower side of the measuring unit 14 and receive the material which it discharges. The middle portion of the spout 15, where it passes through the door 3, is tubular and its lower end is trough-shaped and flattened so that a receptacle such as an envelope which is to receive the measured quantity of the powdered or granular material readily may be applied.

The funnel 13 is provided with the bar 16 which extends across and slightly above the throat of the funnel and facilitates the movement of the material from the hopper 3 to the measuring unit 14, presumably by breaking the column of material extending from the measuring unit upward through the funnel and the hopper and preventing packing of the material in the throat of the funnel.

The measuring unit 14 is mounted on the door 3 with the aid of the bracket 17 and consists of the cylindrical member 18 closed at its front end, that is, the end adjacent the door 3, by the integral or permanent wall 19 having a central circular opening 20 and at its rear end by the removable plug 21 which is provided with a central circular opening 22. The upper side of the cylinder 18 is provided with an opening 23 which communicates with the passage 24 in the block 25. The lower portion of block 25 is rectangular in horizontal cross section and is shaped to fit and is secured to the upper side of cylinder 18. The upper portion of block 25 is cylindrical and fits into the throat of and supports the funnel 13. The rectangular portion of block 25 is secured to the bracket 17 and in this way the measuring unit is supported upon the door 3.

The lower side of the cylinder 18 is provided

with an elongated opening 26 for the discharge of material into the spout 15.

Rotatably mounted within the cylinder 18 is a second cylinder 27. The front end of cylinder 27 is closed by the integral or permanent wall 28 which carries the integral forwardly projecting internally threaded tubular member 29. The tubular member 29 fits and extends through the opening 20 in the front wall 19 of the cylinder 18 and thus provides the front bearing for rotatably supporting the cylinder 27 within the cylinder 18. The rear end of cylinder 27 is closed by the screw plug 30 which carries the rearwardly projecting shaft 31 which latter fits and extends through the opening 22 in the plug 21 and thus provides the rear bearing rotatably supporting cylinder 27 within cylinder 18. The projecting end of shaft 31 carries the weighted arm 12.

The size of the chamber within the cylinder 27 may be varied by movement of the plug 31 carried on the end of the shaft 32 which extends through the tubular member or sleeve 29. The shaft 32 carries the lock nut 33 and knurled head 34 for screwing it through the sleeve 29 and locking it in any desired position. The cylinder 27 has an opening 35 which registers with openings 23 and 26 for filling and emptying the chamber. It will be observed that the cylinder 27 fits snugly within the cylinder 18 for about half of its length including that portion which contains the opening 35 whereas the remainder is tapered slightly. This expedient has been found to avoid the binding of cylinder 27 within cylinder 18 which binding was a frequent troublesome occurrence when cylinder 27 was not tapered but snugly fitted cylinder 18 throughout its length.

The operation of the machine described above is as follows: The hopper 4 is filled, the control of motor 7 is set to operate at the desired speed, say 60 revolutions per minute, and the plug 31 adjusted to give the desired capacity in the chamber within the cylinder 27. As the motor rotates the rubber jacketed end 11 of finger 9 contacts the weighted arm 12 and raises it to top position at which the opening 35 in cylinder 27 is in line with the opening 23 in cylinder 18 and the finely divided material flows from the hopper 4 through the funnel 13 and passage 24 and fills the chamber. Then as the arm 12 passes the vertical position it falls to its bottom position, illustrated in Fig. 2, at which opening 35 is in line with the opening 26 in cylinder 18 and the material in the chamber is discharged into the spout 15. The irregular rotary movement of the cylinder 27 so produced favors the complete filling and emptying of the chamber at each revolution. On the up stroke of the arm 12 it moves relatively slowly so that the opening 35 communicates with the opening 23 and passage 24 for a sufficiently long time to permit complete filling of the chamber. On the down stroke of arm 12 it moves ahead of the finger 11 and comes to rest or oscillates briefly while the opening 35 is in communication with opening 26 thereby permitting the material in the chamber to be completely discharged before the finger 11 catches up with and contacts the arm 12 and moves it and the cylinder 27 to a position at which communication between openings 35 and 26 is closed.

The machine has been found to operate efficiently at speeds of the order of 60 charges per minute with free flowing powdered or granular

material and to give a sufficiently accurate measure of the quantity of material delivered when the quantity is of the order of about 5 grams. The charges of material may be delivered into receptacles such as envelopes placed under the chute manually or automatically.

The invention is not concerned with the manner in which the hopper 4 is kept supplied with material or the manner in which the material discharged from the machine is packaged, and it is, of course, within the scope of the invention to alter the size of the apparatus to adapt it to handle different quantities of material, to modify the spout 15 or replace it by other means for the delivery of the material and to substitute means other than the motor 7 for rotating the measuring device. Other changes in the machine within the scope of the invention as defined in the appended claims will be apparent.

We claim:

1. Dispensing apparatus comprising a measuring unit, means for supplying powder to said measuring unit and means for receiving and delivering the powder discharged from said measuring unit, said measuring unit comprising a stationary housing which is circular in cross section and the axis of which is substantially horizontal, a rotary member which is circular in cross section and is rotatable on its substantially horizontal axis within said housing; a chamber within said rotary member, an opening from said chamber through the surface of said rotary member and spaced from at least one end thereof, an upper opening in said housing adapted to communicate with said opening in said rotary member when the latter is in its uppermost position, a lower opening in said housing adapted to communicate with the opening in said rotary member in its lowermost position, said rotary member fitting snugly within said housing over the length of the opening in said rotary member but being smaller than said housing beyond said opening, and said lower opening in said housing extending below the smaller portion of said rotary member.

2. Dispensing apparatus for finely divided solid material comprising a measuring member rotatably mounted on a substantially horizontal axis, said member having a chamber therein adapted to receive and to discharge finely divided solid material at its filling and discharge positions respectively, a casing surrounding said member and having a filling opening and a discharge opening which communicate with said chamber in its filling and discharge positions respectively, a substantially vertically disposed passage extending upwardly from said filling opening, said passage having a capacity at least equal to that of said chamber, means for continuously supplying finely divided material to said passage, and means for rotating said member about its axis from its discharge position to its filling position at a rate equal to its average angular velocity, said member being eccentrically weighted to cause it to be rotated by the force of gravity at a rate greater than its average angular velocity from its filling position to its discharge position.

3. Dispensing apparatus for finely divided solid material comprising a measuring member rotatably mounted on a substantially horizontal axis, said member having a chamber therein adapted to receive and to discharge finely divided solid material at its filling and discharge positions, respectively, a casing surrounding said member and having a filling opening and a discharge

opening which communicate with said chamber in its filling and discharge positions respectively, a substantially vertically disposed passage extending upwardly from said filling opening, said passage having a capacity at least equal to that of said chamber, means comprising a funnel provided with a transverse bar extending across and immediately above its throat for continuously supplying finely divided material to said passage, and means for rotating said member about its axis from its discharge position to its filling position at a rate equal to its average angular velocity, said member being eccentrically weighted to cause it to be rotated by the force of gravity at a rate greater than its average angular velocity from its filling position to its discharge position.

4. Dispensing apparatus for finely divided solid material comprising a measuring member rotatably mounted on a substantially horizontal axis, said member having a chamber therein adapted to receive and to discharge finely divided solid material at its filling and discharge positions respectively, a casing surrounding said member and

having a filling opening and a discharge opening which communicate with said chamber in its filling and discharge positions respectively, a substantially vertically disposed passage extending upwardly from said filling opening, said passage having a capacity at least equal to that of said chamber, means for continuously supplying finely divided material to said passage, and means for rotating said member about its axis from its discharge position to its filling position at a rate equal to its average angular velocity, said member being eccentrically weighted to cause it to be rotated by the force of gravity at a rate greater than its average angular velocity from its filling position to its discharge position and said measuring member being in substantially powder-tight contact with the casing in a zone extending on each side of said filling opening and clearing said casing in a region outside of said zone toward at least one end thereof sufficiently to permit free movement of the finely divided solid material.

JOHN H. BREWER.

HARRY ELLSWORTH TAYLOR.