



(19) **United States**

(12) **Patent Application Publication**  
**Ali**

(10) **Pub. No.: US 2012/0051902 A1**

(43) **Pub. Date: Mar. 1, 2012**

(54) **HYDRO TURBINE**

(52) **U.S. Cl. .... 415/208.2**

(75) **Inventor: Kasim Ali, Kuala Lumpur (MY)**

(73) **Assignee: ONE HYDRO SDN. BHD., Kuala Lumpur (MY)**

(21) **Appl. No.: 13/257,457**

(22) **PCT Filed: Apr. 26, 2010**

(86) **PCT No.: PCT/MY2010/000065**

§ 371 (c)(1),  
(2), (4) **Date: Sep. 19, 2011**

(30) **Foreign Application Priority Data**

Apr. 29, 2009 (MY) ..... PI 20091732

**Publication Classification**

(51) **Int. Cl.**  
**F04D 29/44** (2006.01)

(57) **ABSTRACT**

There is disclosed an improved hydro turbine assembly (1) that offers high productivity, high operating versatility and minimal and/or no cavitation for an improved efficiency. The present invention proposes a new hydro turbine assembly having substantially higher energy conversion process as well as versatile range of capability from low to high head applications. The hydro turbine assembly (1) comprises of at least an inlet connection (2), an inboard casing (3) and an outboard casing (4) and a turbine runner (6) arranged internally toward the end of the inlet connection (2), the turbine runner (6) is mechanically connected to a turbine shaft (7) arranged with means to generate mechanical energy by the rotation of the turbine shaft (7); characterized in that the inlet connection (2) and the turbine runner (6) are arranged such that water enters into the turbine in the same axis as of the turbine shaft (7) but from the opposite end and leaves it in a radial direction through the turbine runner (6). The turbine may be installed in a normal or in the open plume configuration.

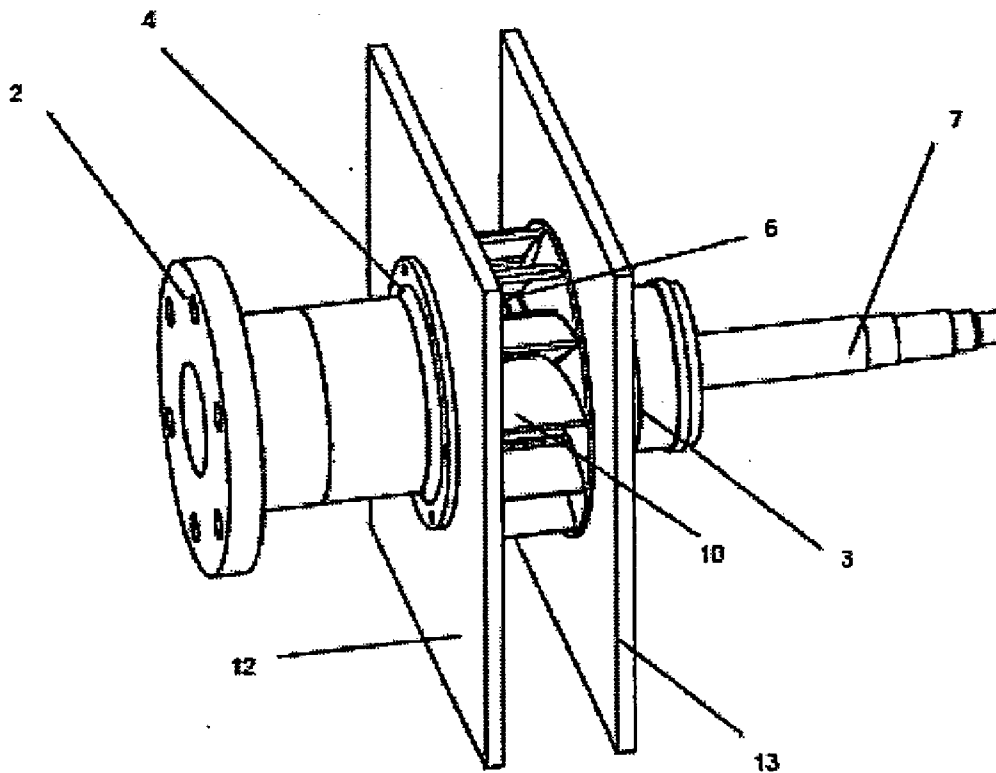

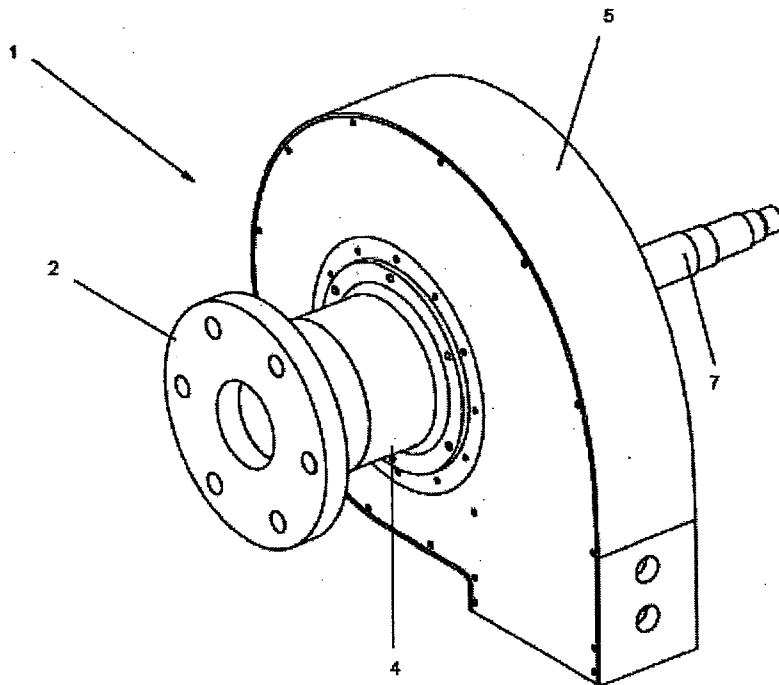

Figure 1

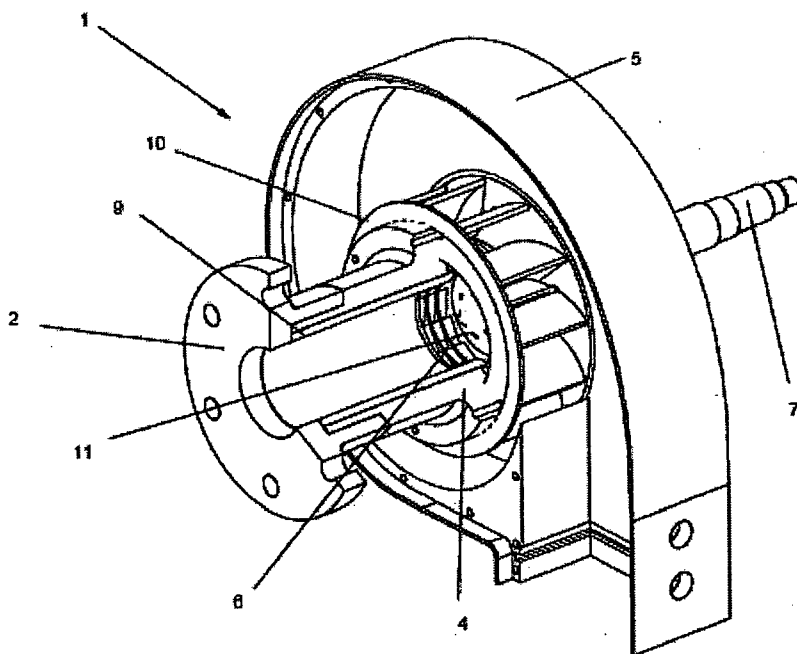

Figure 2

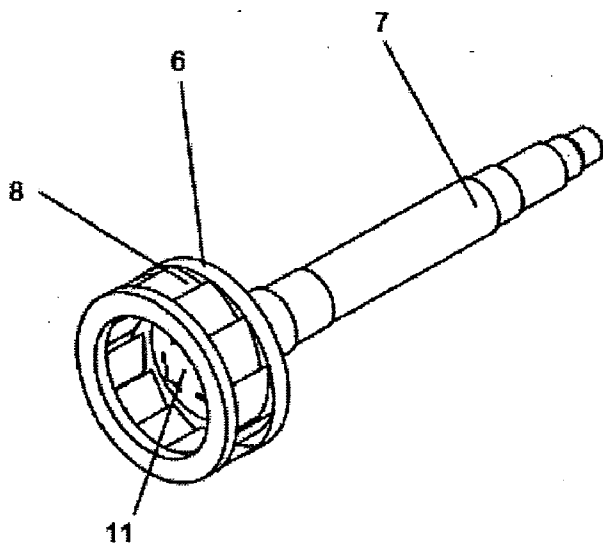

Figure 3

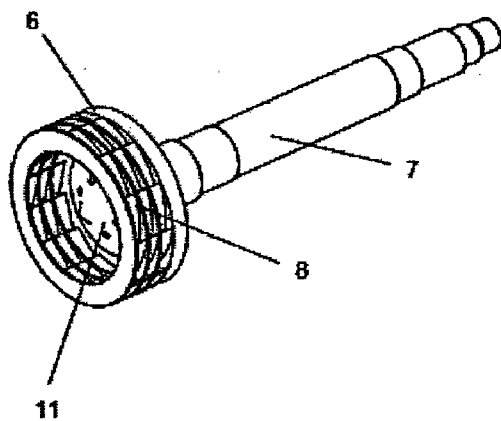

Figure 4

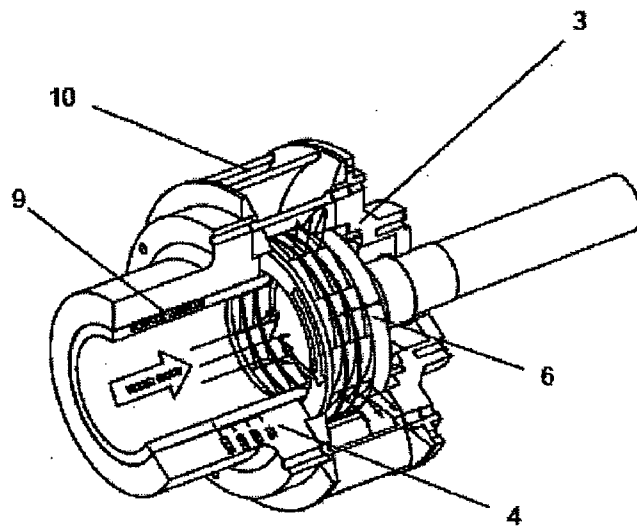

Figure 5

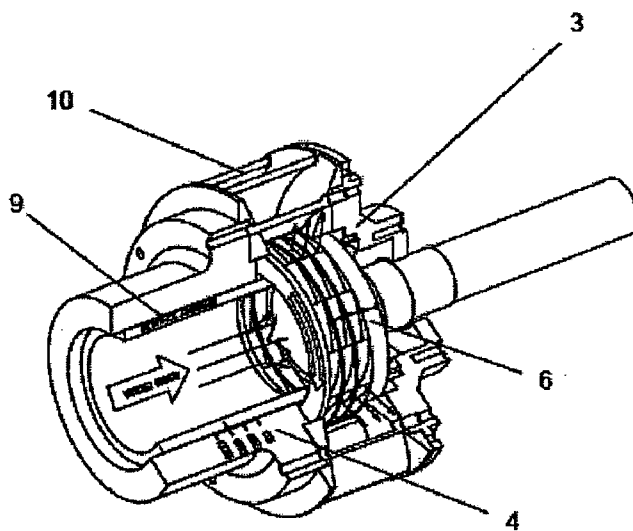

Figure 6

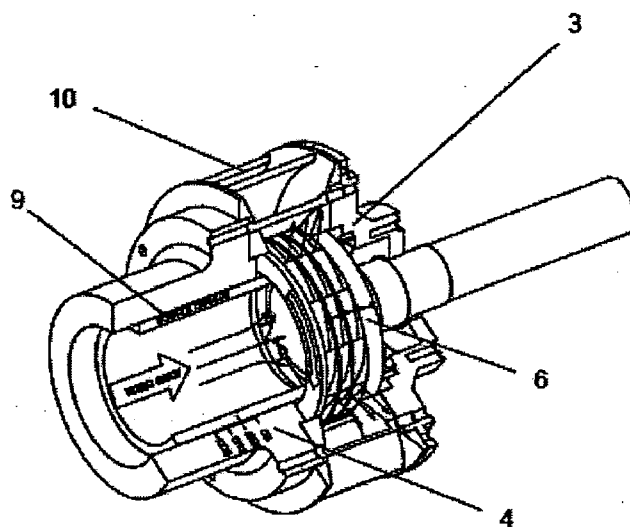

Figure 7

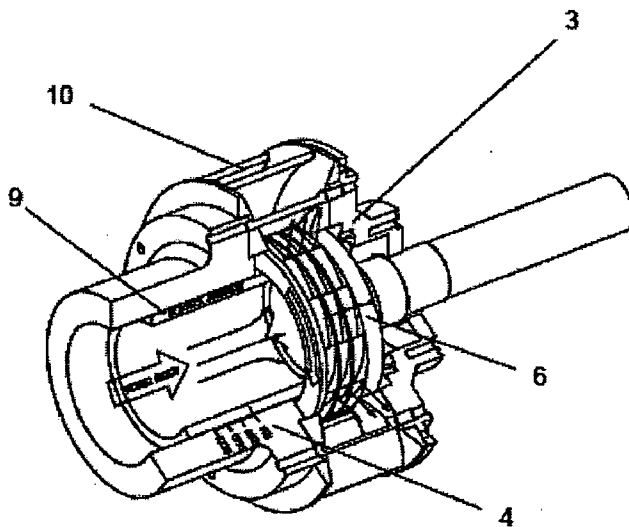

Figure 8

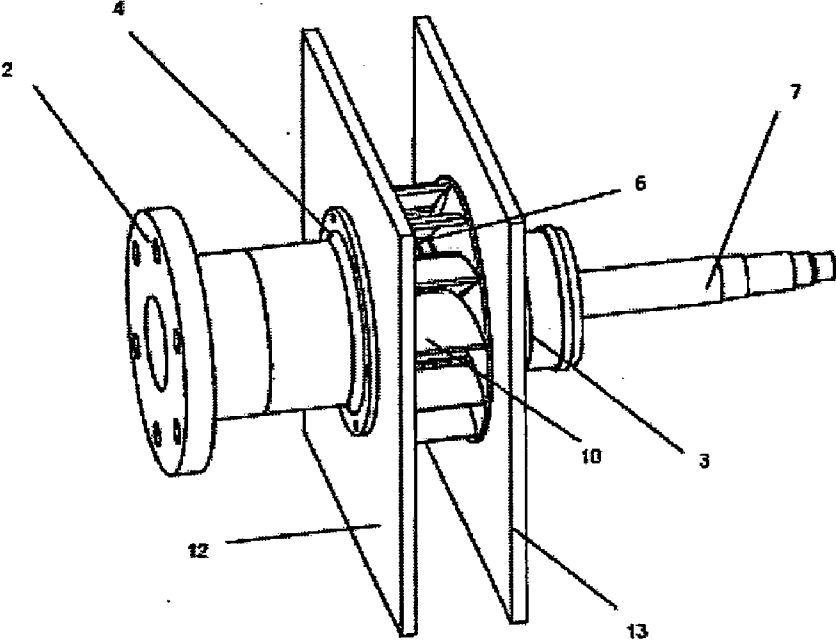

Figure 9

**HYDRO TURBINE**

**1. TECHNICAL FIELD OF THE INVENTION**

[0001] The present invention relates generally to hydro turbine having improved water entry and exit features for higher efficiency and better energy conversion characteristic for driving of mechanical equipment and the likes and specifically for electrical power generation. The present invention focuses on engineering the flow of liquid into the turbine runner in axial direction and exiting the runner in radial axis.

**2. BACKGROUND OF THE INVENTION**

[0002] Hydro turbines can be found in many configurations, shapes and sizes, ranging from the relatively simple to the most sophisticated used in hydro power plants utilizing computerized control with combination of multiple turbines. Common types of hydro turbines are Francis turbine, Kaplan turbine, Pelton turbine, Banki turbine and Turgo turbine. These turbines operate by converting energy from the liquid into mechanical energy then to electrical energy. Differences are present in the configuration of the known hydro turbines especially with regard to water entry or exit direction, runner utilization, impact of centrifugal force on water flow and obstruction to the water flow.

[0003] In some of these prior hydro turbine configurations, especially for the Pelton, Banki and Turgo turbines type, runner utilization is generally low where at any moment in time only a certain sector of the runner is utilized to convert energy. These turbines are generally expensive for low head locations due to their low specific energy conversion (kW/kg) implying a big quantity of material usage for the same output.

[0004] Loss of energy due to cavitation is common for Francis and Kaplan turbines due to the twisting nature of the water leaving these turbines. These cavitations are difficult to handle making these turbines unsuitable for high head applications where the twisting effect is worse. Cavitations also cause damage to turbine runner in the long run.

[0005] Further, in some other turbine designs, the centrifugal force in the water generated by the rotation of the runner opposes the naturally available water force due to the water head. Thus the net force available for energy conversion is limited by the centrifugal force. This is true for Francis and Banki turbines. This reduces the specific energy conversion factor (in kW/kg) of the runners and makes these turbines unsuitable for low head applications.

[0006] Also, in some existing design such as Kaplan and Banki turbines the turbine shaft is positioned by design along the water path causing obstruction to the flow of the water. This results in reduction in efficiency and power output.

[0007] Higher specific energy conversion factor (kW/kg), more efficient energy conversion process of the runner and a more versatile design for low, medium and high head applications are thus generally preferred.

[0008] It is therefore an object of the present invention to provide an alternative configuration of a hydro turbine assembly that delivers high productivity, versatile in use which allows operation in all low, medium and high water head applications and efficient in operation. It is also the object of the present invention to provide an improved hydro turbine assembly that produces minimal and/or no vortices and cavitations and hence resulting in low maintenance requirement. The improved hydro turbine of the present invention shall be

called DAENG hydro turbine in reference to Dual Axis Engineering, the Applicant of the present application.

**3. SUMMARY OF THE INVENTION**

[0009] It is an object of the present invention to provide a hydro turbine assembly having higher energy conversion feature by maximizing the runner utilization.

[0010] It is also another object of the present invention to provide a hydro turbine assembly having the water to flow out in the same direction of the centrifugal force which acts in a radial direction produced by the rotating runner resulting in an even higher energy conversion.

[0011] Yet, it is another object of the present invention to provide a hydro turbine assembly that produces no twisting effect on the water at the turbine exit resulting in minimal and even no cavitation.

[0012] These and other objects of the present invention are accomplished by providing,

[0013] A hydro turbine assembly (1) comprises of at least an inlet connection (2), an inboard casing (3) and an outboard casing (4); and

[0014] a turbine runner (6) arranged internally toward the end of said inlet connection (2) and positioned between the outboard casing (4) and inboard casing (3), said turbine runner (6) is mechanically connected to a turbine shaft (7) having provided thereto the means to generate mechanical energy by rotation of the turbine shaft (7);

[0015] characterized in that,

[0016] said inlet connection (2) and turbine runner (6) are arranged such that water enters said turbine along the same axis as the turbine shaft (7) but from the opposite end, changes its direction to the radial direction by the use of a curved conical member (11), enters the cavity between runner blades (8) and leaves the runner (6) in the radial direction without being obstructed by the turbine shaft (7).

[0017] Preferably, the turbine runner (6) has a plurality of blades and their surfaces shaped in such a way that the water entering the runner will pass through the gaps between the blades and directed to exit the runner in the same direction of the centrifugal force of the rotating runner.

[0018] Yet, it is also preferable that a control annulus (9) is incorporated with the turbine assembly to control the power output of the turbine.

[0019] Further, it is also preferable that the runner is set in wet state at all time during operation of the turbine.

[0020] Also, it is preferable that the hydro turbine is capable of operating over a wide range from low to high water head operations.

**4. BRIEF DESCRIPTION OF THE DRAWINGS**

[0021] The embodiments of the invention will now be described, by way of example only, with reference to the accompanying figures in which:

[0022] FIG. 1 shows perspective view of a hydro turbine assembly configured according to the embodiment of the present invention;

[0023] FIG. 2 shows partially cross-sectional view of the hydro turbine assembly configured according to the present invention;

**[0024]** FIG. 3 shows a perspective view of the turbine runner with a single disc and the turbine shaft arrangement of the present invention;

**[0025]** FIG. 4 shows another perspective view of the turbine runner and turbine shaft arrangement, the runner having a plurality of discs.

**[0026]** FIG. 5 shows a partially cross-sectional view of the hydro turbine shaft that shows the water flow direction utilized in the present invention and the application of control annulus set to 100% position to manage the power output of the present invention;

**[0027]** FIG. 6 shows a partially cross-sectional view of the hydro turbine shaft that shows the water flow direction utilized in the present invention and the application of control annulus set to 67% position to manage the power output of the present invention;

**[0028]** FIG. 7 shows a partially cross-sectional view of the hydro turbine shaft that shows the water flow direction utilized in the present invention and the application of control annulus set to 33% position to manage the power output of the present invention;

**[0029]** FIG. 8 shows a partially cross-sectional view of the hydro turbine shaft that shows the water flow direction utilized in the present invention and the application of control annulus set to 0% position to manage the power output of the present invention;

**[0030]** FIG. 9 shows an alternative hydro turbine assembly of the present invention set in an open plume configuration.

## 5. DETAILED DESCRIPTION OF THE DRAWINGS

**[0031]** Referring now to the figures, first to FIG. 1, there is shown the perspective view of an improved hydro turbine assembly of the present invention. The hydro turbine (1) comprises of among others, a water inlet connection (2), a turbine shaft (7), a turbine runner (not shown) and various casings. At the end section of the turbine shaft (7) there is provided a mechanical as well as electrical means normally associated with electrical power generation that convert water pressure energy to mechanical energy and later as electrical energy. Such means typically includes an electric generator (not shown). The general concept of hydro turbine works as follows: flowing water is directed on to the blades (not shown) of a turbine runner (also not shown) through the inlet connection (2) thus creating a torque on the blades and causing the runner to spin. The spinning of the turbine runner implies the transformation of pressure energy of the water flow to mechanical energy in the turbine shaft. The exited water with a diminished energy is directed to flow out to follow the general shape of the casing that encloses the turbine runner. In this proposed invention, the casing is in the shape of spiral, aptly called spiral casing (5). It is also envisaged that the alternative turbine assembly of the present invention could also be installed in an open plume configuration as shown in FIG. 9. In such situation, no such casing is necessary; instead an outboard water wall (12) and an inboard water wall (13) are arranged on each side. Such walls however need not be part of the turbine assembly but as part of civil supporting structures. In this open plume configuration, the turbine is anchored directly to the walls obviating the need to for a spiral casing discussed earlier.

**[0032]** In the embodiment of the present invention, the water enters the turbine in the same axis of the turbine shaft (axially) but on the opposite end of the shaft and leaves

radially through the turbine runner. As a result of this preferred embodiment, water flows freely without obstruction caused by the turbine shaft (7) and flows out of the runner in the same direction as the centrifugal force produced by the rotating runner. The centrifugal force has a positive effect to the water flow, and this would advantageously allow the turbine to operate in low head applications. Such features provide versatility to the improved turbine assembly.

**[0033]** Referring now to FIGS. 2, 3 and 4 where FIG. 2 shows partial cross-sectional view of hydro turbine configured according to the present invention. In this figure the turbine assembly (1) is shown comprises of the inlet connection (2), an outboard casing (4), and the spiral casing (5). The turbine runner (6) is shown comprises of a curved conical member (11) located at the center of the runner (6), a plurality of blades (8) arranged along the circumference or perimeter of the runner. The inlet connection (2) is provided so as to make the water enter the axially into the turbine runner (6). The curved conical member (11) is generally formed to change the direction of the water that enters in axial direction to radial direction into runner without causing cavitation. Each of the runner blades is having its surface positioned to direct the water entering the runner to exit in the same direction of the centrifugal forces produced by the rotating runner. In the preferred embodiment, the runner may be made of a singularity of blades (see FIG. 3) or a plurality of discs each of the discs having similar arrangement of blades (see FIG. 4).

**[0034]** Still referring to FIG. 2, an exit ring (10) is arranged within the turbine assembly to enclose the turbine runner while allowing it to rotate freely. The exit ring also functions as a joint between the inboard casing (3) and the outboard casing (4) as well as to direct the water leaving the turbine runner to the general direction of the spiral casing (5) so as to limit or eliminate any obstruction to the water flow. A control annulus (9) is arranged within the cavity of the outboard casing (4) and the control annulus is designed to be able to slide in and out of the turbine runner so that the power output of the turbine could be controlled. The control annulus slides in the axial direction to cause the discs of the runner to completely shut or opened depending on the requirement. The most efficient control point is achieved at the point where one or more discs are shut completely while the unaffected discs are kept fully open. FIGS. 5, 6, 7 and 8 show the location of the control annulus when the turbine is set at 100%, 67%, 33% and 0% load position, respectively. As seen in the figure, controlling the output power of the turbine could be done easily.

**[0035]** FIG. 3 shows an exploded view of the arrangement of the turbine runner and the turbine shaft. The runner (6) is suitably connected to the shaft end using suitable connection known in the art. The figure also shows the arrangement of the blades (8) as well as the curved conical member (11) of the runner. Water entering axially to the runner will be directed toward the blade surface by the conical member and causes the runner to rotate. It is highly believed that with such arrangement and assembly, there will be little chance for cavitation to be generated.

**[0036]** FIG. 4 shows another exploded view of the arrangement of the turbine runner and the turbine shaft whereby the runner is made of plurality of discs. Such arrangement allows more control to the turbine output.

**[0037]** FIG. 5 shows how such advantageous water flow could be realized by the present invention. Water entering the runner axially through the connection and made to flow out

radially through the runner. At the exit of the runner there would be very minimal amount of energy left. The water leaves the runner with the remnant of energy through the exit ring (10) and then to the spiral casing (5).

[0038] Turbine constructed having such features will have the following advantages:

[0039] 1. Runner utilization could be maximized for higher energy conversion. This will result in higher specific energy conversion (kW/kg) characteristic.

[0040] 2. As the runner is intended to operate in a wet state at all time, the turbine is not subjected to problems of dual phase condition. Such dual phase condition is difficult to control and generally results in loss of efficiency. Therefore, the proposed turbine would have a higher level of efficiency compared to prior turbine operation.

[0041] 3. Water flows into the turbine runner freely and not obstructed by the turbine shaft unlike few known turbines. A runner for a turbine of the present invention would allow higher water flow thus delivers higher power output compared to similarly sized runner of the prior art.

[0042] 4. Water flows out of the runner in the same direction as the centrifugal force produced by the rotating runner. In some of the known turbines, the centrifugal force opposes the water flow thus having a negative impact to the output, while in some other designs the centrifugal force has a neutral effect. However, the centrifugal force of the present invention is in the same direction of the water flow and would have a positive impact on the water flow thus resulting in positive net force thus offering an even higher specific energy conversion and enable operation even at low water heads.

[0043] 5. Minimum vortices and cavitations will be present in the turbine as the water exits in radial direction without any twisting effect. In the known turbine assembly, axial water flow out will result in twisting water flow due to imperfection of the blade profile combined with rotation of the shaft. Cock-screw pattern in twisting water flow will result in vortices and cavitations and limits high head applications where the effect will be more severe. Advantageously, since the head has little influence on the formation of vortices and cavitations, the present invention is suitable for a wide range applications from very low heads to very high head.

[0044] FIGS. 5, 6, 7 and 8 show the position of the control annulus (9) where the control annulus is used to control the output of the turbine. By controlling the opening or closing of the runner discs, suitable set-up to cater varying power requirements could be implemented without much difficulty.

[0045] FIG. 9 shows the arrangement of the turbine assembly when arranged in an open plume configuration. The turbine assembly could therefore be set in many configurations suitable to the requirement of the location.

[0046] It is envisaged that feature of the present invention could be implemented to replace the existing hydro turbines or can be used in a new hydro turbine installation. While the preferred embodiments of the present invention have been described, it should be understood that various changes, adaptations and modifications may be made thereto. It should be understood, therefore, that the invention is not limited to

details of the illustrated invention shown in the figures and that variations in such minor details will be apparent to one skilled in the art.

1. A hydro turbine assembly (1) comprises of at least an inlet connection (2), an inboard casing (3) and an outboard casing (4); and

a turbine runner (6) arranged internally toward the end of said inlet connection (2) and positioned between the outboard casing (4) and inboard casing (3), said turbine runner (6) is mechanically connected to a turbine shaft (7) having provided thereto the means to generate mechanical energy by rotation of the turbine shaft (7); characterized in that,

said inlet connection (2) and turbine runner (6) are arranged such that water enters said turbine along the same axis as the turbine shaft (7) but from the opposite end, changes its direction to the radial direction by the use of a curved conical member (11), enters the cavity between runner blades (8) and leaves the runner (6) in the radial direction without being obstructed by the turbine shaft (7).

2. A hydro turbine assembly as claimed in claim 1, further characterized in that the inlet connection (2) is positioned in such a way that water enters axially into the turbine runner (6).

3. A hydro turbine assembly as claimed in claim 2, further characterized in that said turbine runner (6) is configured from a singularity or plurality of discs and each of said discs having plurality of blades (8) secured thereto.

4. A hydro turbine assembly as claimed in claim 3, further characterized in that a control annulus (9) is arranged within the outboard casing (4) and reaches the turbine runner (6), said control annulus (9) is capable of being slide in and out of the turbine runner (6) such that water flowing into the turbine runner can be controlled by blocking the water flowing in one or more discs to manage the power output of the hydro turbine.

5. A hydro turbine assembly as claimed in claim 4, further characterized in that an exit ring (10) is arranged to enclose the said turbine runner (6) while allowing it to rotate freely, the said exit ring (10) operates as a joint between the inboard casing (3) and the outboard casing (4), and directing the water leaving the turbine runner (6) to the direction of a spiral casing (5).

6. A hydro turbine assembly as claimed in claim 1, further characterized in that the turbine runner (6) is set to operate in wet state at all time.

7. A hydro turbine assembly as claimed in claim 6, further characterized in that the runner utilization is fully maximized at the maximum load position.

8. A hydro turbine assembly as claimed in claim 7, further characterized in that said hydro turbine is capable of being used in a low, medium and high water head application.

9. A hydro turbine assembly as claimed in claim 4, further characterized in that said turbine assembly may also be set in an open plume turbine configuration.

10. A hydro turbine assembly as claimed in claim 9, further characterized in that an outboard water wall (12) and an inboard water wall (13) are incorporated as supporting civil structure to the hydro turbine assembly set in the open plume configuration.

\* \* \* \* \*