

(19) World Intellectual Property Organization
International Bureau



(43) International Publication Date
20 May 2010 (20.05.2010)

PCT

(10) International Publication Number
WO 2010/056661 A1

(51) International Patent Classification:
H01L 27/14 (2006.01)

(21) International Application Number:
PCT/US2009/063857

(22) International Filing Date:
10 November 2009 (10.11.2009)

(25) Filing Language: English

(26) Publication Language: English

(30) Priority Data:
61/193,258 12 November 2008 (12.11.2008) US
12/327,383 3 December 2008 (03.12.2008) US

(71) Applicant (for all designated States except US): BAE SYSTEMS INFORMATION AND ELECTRONIC SYSTEMS INTEGRATION INC. [US/US]; PO Box 868, Nashua, NH 03061-0868 (US).

(72) Inventors; and

(75) Inventors/Applicants (for US only): SILVA, Raymond, J. [US/US]; 8 Juniper Drive, Saugus, MA 01906 (US). BOWLER, Dennis, P. [US/US]; 220 Morse Road, Sudbury, MA 01776 (US). ROBILLARD, Gene, A. [US/US]; 2 Lexington Street, Stoneham, MA 02180 (US).

(74) Agent: LONG, Daniel, J.; BAE Systems Information And Electronic Systems, Integration Inc., PO Box 868, Nashua, NH 03061-0868 (US).

(81) Designated States (unless otherwise indicated, for every kind of national protection available): AE, AG, AL, AM, AO, AT, AU, AZ, BA, BB, BG, BH, BR, BW, BY, BZ, CA, CH, CL, CN, CO, CR, CU, CZ, DE, DK, DM, DO, DZ, EC, EE, EG, ES, FI, GB, GD, GE, GH, GM, GT, HN, HR, HU, ID, IL, IN, IS, JP, KE, KG, KM, KN, KP, KR, KZ, LA, LC, LK, LR, LS, LT, LU, LY, MA, MD, ME, MG, MK, MN, MW, MX, MY, MZ, NA, NG, NI, NO, NZ, OM, PE, PG, PH, PL, PT, RO, RS, RU, SC, SD, SE, SG, SK, SL, SM, ST, SV, SY, TJ, TM, TN, TR, TT, TZ, UA, UG, US, UZ, VC, VN, ZA, ZM, ZW.

(84) Designated States (unless otherwise indicated, for every kind of regional protection available): ARIPO (BW, GH, GM, KE, LS, MW, MZ, NA, SD, SL, SZ, TZ, UG, ZM, ZW), Eurasian (AM, AZ, BY, KG, KZ, MD, RU, TJ, TM), European (AT, BE, BG, CH, CY, CZ, DE, DK, EE, ES, FI, FR, GB, GR, HR, HU, IE, IS, IT, LT, LU, LV, MC, MK, MT, NL, NO, PL, PT, RO, SE, SI, SK, SM, TR), OAPI (BF, BJ, CF, CG, CI, CM, GA, GN, GQ, GW, ML, MR, NE, SN, TD, TG).

Published:

— with international search report (Art. 21(3))



WO 2010/056661 A1

(54) Title: HIGH DENSITY COMPOSITE FOCAL PLANE ARRAY

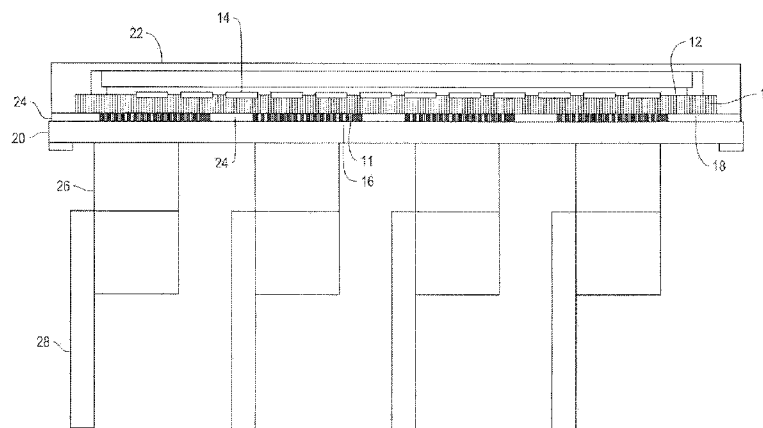

FIG. 1

(57) Abstract: A composite focal plane assembly with an expandable architecture has a multi-layer, double-sided aluminum nitride (AlN) substrate and vertical architecture to achieve the dual function of focal plane and electronics backplane. Imaging dice and other electrical components are mounted and wire bonded to one surface and then direct backplane connectivity is provided on the opposing surface through a matrix of electrical contacts. In one embodiment, a flexible connector is sandwiched between the AlN focal plane and a FR-4 backplane is used to compensate for differences in coefficient of thermal expansion (CTE) between the AlN and commercially available high density circuit card connectors that are commonly manufactured from materials with CTE properties more closely approximating FR-4. In an alternate embodiment, the FR-4 and flexible connectors are eliminated by using high density circuit card connectors that are fabricated out of materials more closely matching the CTE of AlN.

HIGH DENSITY COMPOSITE FOCAL PLANE ARRAY

FEDERALLY SPONSORED RESEARCH

[0001] The present invention was made with United States Government support under Contract No. FA8650-07-C-7732. The United States Government has certain rights in the present invention.

1. Technical Field

[0002] The present invention relates to a very large format imaging focal plane array with an expandable architecture that can be used to make a gigapixel camera. More particularly, the invention relates to an apparatus that consolidates the functions of a large scale Focal Plane , signal distribution substrate, heat sink and motherboard into a single planar assembly having a vertical architecture wherein the signal leads from hundreds of active, video and passive components mounted on the top surface of the focal plane are routed through a multi layer, thermally conductive, flat and stiff circuit card substrate to the back surface where the signal lines are formed into a matrix of electrical contacts that can be connected directly or nearly directly to a group of connectors serving as a backplane interface to a set of processing electronics circuit cards.

2. Description of Related Art

[0003] Imaging dice are commonly mounted singularly into a device carrier package or sometimes in small groups onto a common substrate. Electrical die connections are then wire bonded to contacts either within the chip carrier or down to the substrate where they are typically routed to the sides of the focal plane assembly away from the active centers of the die to sites along periphery where additional

connections can be made to external circuitry. The external circuits are commonly connected using either flex or wired cables.

[0004] However, when the size of the imaging plane board is limited, and a large number of imaging die are required, the prior art construction is pushed beyond its limits in terms of size and the number of connections which is achievable by making connections at the perimeter of the imaging plane board.

[0005] It is therefore desirable to provide an optically flat imaging plane board having a small perimeter in proportion to the number of imaging dies placed upon the board.

[0006] It is likewise desirable that a large scale focal plane handling tens or hundreds of power consuming dice be thermally conductive in order to dissipate the significant amounts of heat being generated by the devices under power.

SUMMARY

[0007] In accordance with one preferred embodiment of the invention, an aluminum nitride (AlN) board is used in a composite focal plane array. The aluminum nitride board can be fabricated into a multi-layer, two sided circuit card assembly, can be post polished to optically flat tolerances, is structurally stiff and is highly thermally conductive which enables it to dissipate large amounts of heat. Also, the coefficient of thermal expansion of the AlN closely matches that of imaging dice which are constructed out of silicon wafers. However, the aluminum nitride board has substantially lower coefficient of thermal expansion (CTE) than conventional FR-4 and similar fiber glass materials used most commonly for commercial circuit card construction. Additionally, manufacturers of high density backplane connectors typically fabricate their products out of Liquid Crystal Polymer (LCP) or similar materials to more closely match the CTE of the FR-4 and other like materials. In this

embodiment of the invention, a flexible connector array is connected between the imaging plane board back surface and the motherboard. The flexible connector allows compensation for the difference in the coefficient of thermal expansion. The imaging dies are connected to vias (electrically conducting paths) in the imaging plane board by wire bond connections. The configuration of the die wire bond connections to the vias in the imaging plane board are around the perimeter of each imaging die. The imaging plane board provides for distribution of signals and via paths through multiple layers of the board, which provide for an array of connections on the backside of the board. A land grid array (LGA) type connector or other flexible connector is then used to connect the imaging plane board to a back plane motherboard. Use of an LGA type connector provides a flexible connector between the FR-4 motherboard and the AlN imaging plane board, which compensates for differences in thermal coefficient expansion.

[0008] All features and advantages of the present invention will become apparent in the following written detailed description and claims.

[0009] In a second embodiment of the invention 8, an aluminum nitride (AlN) board is used in a composite focal plane array directly without any intermediary FR-4 back plane.

BRIEF DESCRIPTION OF THE DRAWINGS

[0010] The invention and a preferred apparatus is shown not to scale. However, the advantages of the invention and further objects thereof will best be understood by the detailed description as well as the drawings.

[0011] Fig. 1 shows an assembly of the focal plane, the back plane, and the connector of the invention. The drawing is not to scale and illustrates the construction of the preferred embodiment.

[0012] Fig. 2A shows a top view of the focal plane imaging plane board where the imaging dies are mounted. The imaging dies are shown.

[0013] Fig. 2B shows a view of the back surface of the imaging plane board with orderly rows of contact pads.

[0014] Fig. 3A shows a silicone carbide support structure which is used to support connectors between the imaging plane board and the back plane motherboard.

[0015] Fig. 3B shows the connections on the back plane motherboard.

[0016] Fig. 3C shows a stiffening plate which reinforces the FR-4 motherboard and which supports the back plane connectors.

[0017] Fig. 4 shows a compression type connector, which connects the contact pads of the focal plane board and the contacts of the motherboard.

[0018] Fig. 5 shows internal layer traces of the focal plane board connection, which route vias between the top layer bond pads connecting the imaging die to the imaging plane board and the array of contacts on the imaging plane board back surface.

[0019] Fig. 6 shows a composite focal plane array assembly.

[0020] Fig. 7 shows a complete focal plane assembly with the back plane assembly in a camera.

[0021] Fig. 8 shows a second embodiment of the invention which combines the functions of the focal plane board and the mother board.

DETAILED DESCRIPTION OF EMBODIMENTS

[0022] Fig. 1 shows a cross-sectional view of a high-density composite focal plane array with the integral back plane board and camera control modules. The optically flat focal plane board 10 is preferably made of layers of aluminum nitride. A

large number of imaging dies 14 are placed on the top 12 of the board 10. The number of dies may be enough to comprise a gigapixel camera or a quadrant there-off as in this embodiment. Connectors 16 are placed on the bottom side 18 of the focal plane board 10. The connectors 16 connect a back plane motherboard 20 to the focal plane board 10. On top of the entire assembly is a window 22 made of a material such as sapphire. A silicone plate 24 is placed between the imaging plane board and the motherboard and provides a space, which is used to secure the connectors 16. The connectors 16 are sandwiched between the imaging plane board and the FR-4 motherboard 20. The camera assembly, which utilizes the focal plane array and integral back plane array, is also depicted in Fig. 1. SMT connectors 26 connect the motherboard to camera control modules (processing electronics) 28. It should be noted that Fig. 1 is not to scale, and that configurations of the preferred embodiment are shown in photographs, which are Figs. 2-7. Fig. 1 shows the components of the assembly conceptually.

[0023] The connectors 16 provide for compensation for the difference between the thermal expansion rate of the focal plane board 10 and the motherboard 20. The connectors are preferably spring-loaded connectors of the type used for land grid array chips. Typical LGA connectors provide a spring-loaded contact against pads. Examples of suitable connectors for this invention include those shown in the United States Patent Numbers 6,758,683; 6,585,527; and 6,695,624 and Publication Numbers 2006/0186906; 2003/0203664; and 2004/019208. Further, a connector which may be used with this invention is depicted in Fig. 4. The connector 16 is produced by SAMTEC and is identified as GLZ series. This is a solder-less interconnection type connector. As used in this invention, an example of the connector is an array of connections, which are 40 connections by 10 connections for a total of 400 connections. SAMTEC is located at 520 Park East Boulevard, New Albany, Indiana

47150. The SAMTEC GFZ connectors are land grid array socket assemblies which may also be used for connecting boards, or as test devices for testing chips. This invention, however, is not limited to connectors as produced by SAMTEC. Any connector, which provides for contacts which will provide for compensation for the differences in thermal coefficient expansion between the imaging plane board and the back plane motherboard is suitable for use with this invention.

[0024] The optically flat imaging plane board 10 is preferably an aluminum nitride printed circuit board. The aluminum nitride board can provide an optically flat imaging plane and when constructed with a plurality of layers provides vias (electrical connections) through the thickness of the boards. As shown in Fig. 5, the vias 3 (white lines) overlap each other by passing through layers of the board 10 to allow transition from imaging plane layer bond patterns of the imaging die to an array which matches the flexible connectors 16. The aluminum nitride board is currently available in a size of 4.5" x 4.5". With this size board, it is not feasible to provide connections to a motherboard by wire bond connections at the edges of the board 10. The practical limitation is that if the pattern of the imaging die on the surface is square, then the number of imaging die increases as the square of the number on a side. On the other hand, the number of possible wire bond connections around the perimeter of the imaging plane board only increases linearly. For this reason, if a construction with a large number of dies is required, the number of wire bond connections to be made at an edge of an imaging plane board quickly exceeds feasible limits on the size of the board.

[0025] Fig. 2A shows an array of 92 imaging die placed upon an imaging plane board 10. In this figure, wire bonds 32 which connect the imaging dies 14 to the imaging plane board 10 are showing. It can be easily seen that the large number of required connections may exceed the space is available for wire bond connections

around the perimeter of board 10. In this invention, the vias (see Fig. 5) allow rearrangement of the pattern of the wire bond contacts 32 to an array pattern 34 shown in Fig. 2B. Fig. 2B as noted above is the backside of the imaging plane board 10. The array shown in Fig. 2B is, in this example, designed to match an array of a SAMTAC GFC type connector. However, it should be noted that other connectors are suitable with this invention. There may be approximately 5,000 wire bondable pads between the imaging die and the imaging plane board. The bottom of the board 10 may have approximately 1500 pressure contact pads for engaging connector 16. However, the actual number can exceed 3000 allowing for a large number of imaging dies.

[0026] The connections 36 to the motherboard 20 are shown in Fig. 3B. The connections 36 engage the connector 16 to provide contact between the motherboard and the imaging plane board. Fig. 3A shows a frame, which holds connectors 38, and a space 40, which receives connectors 16. Also shown in photograph Fig. 3A are the contacts 34 on the back of imaging plane board 10. Fig. 3C shows a stiffening board 42, which is used to reinforce the FR-4 motherboard 20. This stiffener also supports back plane connectors 36 as shown in Fig. 3B.

[0027] Fig. 6A shows a completed composite focal plane array assembly 50 and Fig. 6B shows an expanded view of the components of the assembly. The imaging plane board 10, the imaging die 14 and the frame 38 previously discussed are shown. In addition, there is shown a bezel 44, which provides separation between the imaging plane board and a sapphire window 48. A support ring 46 is also provided in the completed assembly.

[0028] Fig. 7 shows an overall layout of a camera assembly incorporating the composite focal plane assembly 50 depicted in Fig. 6, a plurality of connectors 16, a back plane motherboard 52 with contacts and camera boards 54.

[0029] In the second embodiment (Fig. 8) the aluminum nitride board is fabricated into a multi-layer two sided circuit card assembly, which is post polished to optically flat tolerances, is structurally stiff and is highly thermally conductive which enables it to dissipate large amounts of heat. Also, the coefficient of thermal expansion of the AlN closely matches that of imaging dice which are constructed out of silicon wafers. With the use of a backplane connector made from materials of similar CTE to the AlN, including but not limited to AlN itself, a direct single layer apparatus is achieved wherein the processing electronics are plugged directly into the AlN focal plane / backplane, eliminating the need for the thermally compensating flexible connector array between the imaging plane board back surface and the motherboard. In this embodiment, the focal plane is the backplane with the imaging die mounted on one surface and the processing electronics plugged directly into connectors mounted on the other surface.

[0030] Fig. 8 shows the second embodiment of the invention where the aluminum nitride composite focal plane board 10 combines the functions of the focal plane and the FR-4 mother board of the first embodiment (Fig. 1). In this case, the coefficient of thermal expansion (CTE) of the aluminum nitride board 10 substantially matches the material of the back plane board connectors 60 and 62. This eliminates the need for a thermally compensating connector 16 which is used in the first embodiment (Fig. 1). In the first embodiment, the FR-4 CTE is not closely matched to the aluminum nitride board.

[0031] While the application has been described in detail herein in accord with certain preferred embodiments thereof, many modifications and changes therein may be effected by those skilled in the art. Accordingly, it is intended by the appended

claims to cover all such modifications and changes as fall within the true spirit and scope of the invention.

WHAT IS CLAIMED IS:

1. A high-density composite focal plane array with an integral back plane comprising in combination:
 - an optically flat imaging plane board having vias through the thickness of the board and having at least one array of contact on a back surface;
 - an array of imaging die on the optically flat imaging plane;
 - a back plane motherboard constructed of a material having a different coefficient of thermal expansion than that of the imaging plane board; and
 - a flexible connector array between the imaging plane board back surface and the motherboard.
2. The apparatus of claim 1 wherein the flexible connector array comprises solderless flexible connectors between the imaging plane board back surface and the motherboard.
3. The apparatus of claim 1 further comprising wire bond connections connecting the imaging die to the vias of the imaging plane board.
4. The apparatus of claim 1 further comprising vias, which are constructed in layers of the imaging plane board, wherein the vias provide a transition from wire bond patterns on the imaging plane to a back surface array, which matches the flexible connector array.
5. The apparatus of claim 1 further comprising an imaging plane board having a coefficient thermal expansion, which is different from a coefficient thermal expansion of the back plane motherboard.
6. The apparatus of claim 1 wherein the imaging board is an aluminum nitride board.

7. The apparatus of claim 1 wherein the motherboard is an FR-4 board.
8. The apparatus of claim 1 wherein the number of vias is substantially greater than the number of vias, which can be placed on a perimeter of the imaging plane board.
9. A focal plane and back plane assembly comprising:
 - an aluminum nitrite printing board;
 - a plurality of imaging dies mounted on the printed wiring board;
 - a plurality of signal lines routed through the printer wiring board;
 - at least one connector connected to the back of the printed wiring board providing an electrical connection to the signal lines of the printed wiring board; and
 - a back plane motherboard having electrical connections to the connector.
10. The apparatus of claim 9 wherein the plurality of imaging dies are mounted on an image receiving plane of the aluminum nitrite printed wiring board and the connector is mounted on the back opposite to the image receiving plane.
11. The apparatus of claim 9 wherein the motherboard is a FR-4 material.
12. A high-density focal plane assembly having an integral back plane comprising:
 - an aluminum nitride print wiring board having a plurality of imaging dies on a first surface and signal lines (vias) routed through the board to a second surface of the board.
 - a back plane motherboard having electrical contacts;
 - a connector sandwiched between the printed wiring board and the motherboard wherein the connector connects the signal lines of the aluminum nitride printed wiring board to the motherboard electrical contacts.
13. A camera comprising:

a focal plane and back plane assembly further comprising:
an aluminum nitride wiring board having an imaging plane and a back surface;
an array of video die mounted on the wiring board imaging plane;
a vertical architecture having vias connecting the imaging plane to the back surface;
a back plane motherboard having electrical contacts; and
a connector mounted between the back of the wiring board and the motherboard.

14. The apparatus of claim 13 further comprising a connector having an array of floating pin contacts.

15. The apparatus of claim 13 wherein the connector is a flexible connector.

16. The apparatus of claim 13 wherein the aluminum nitride wiring board is an optically flat imaging plane.

17. The apparatus of claim 13 wherein the aluminum nitride wiring board provides a heat conductive path for removing heat from the imaging die.

18. The apparatus of claim 13 wherein the plurality of video die provide a gigapixel imaging array.

19. The apparatus of claim 13 further comprising aluminum nitride board having a coefficient of thermal expansion, which is substantially different from a coefficient expansion of the motherboard.

20. The apparatus of claim 19 wherein the coefficient of thermal expansion of aluminum nitride is lower than the coefficient of thermal expansion of the motherboard.

21. A focal plane and back plane assembly comprising:

a plurality of imaging dies mounted on an aluminum nitride wiring board;

a flexible connector;

the apparatus having a vertical architecture combining a focal plane array; and the back plane into a single device including the flexible connector between the wiring board and the back plane.

22. A high-density composite focal plane array with an integral back plane comprising in combination:

an optically flat imaging plane board having vias through the thickness of the board and having at least one array of contact on a back surface;

an array of imaging die on the optically flat imaging plane;

a back plane motherboard constructed of a material having a coefficient of thermal expansion substantially matching that of the imaging plane board; and

a connector array between the imaging plane board back surface and the motherboard.

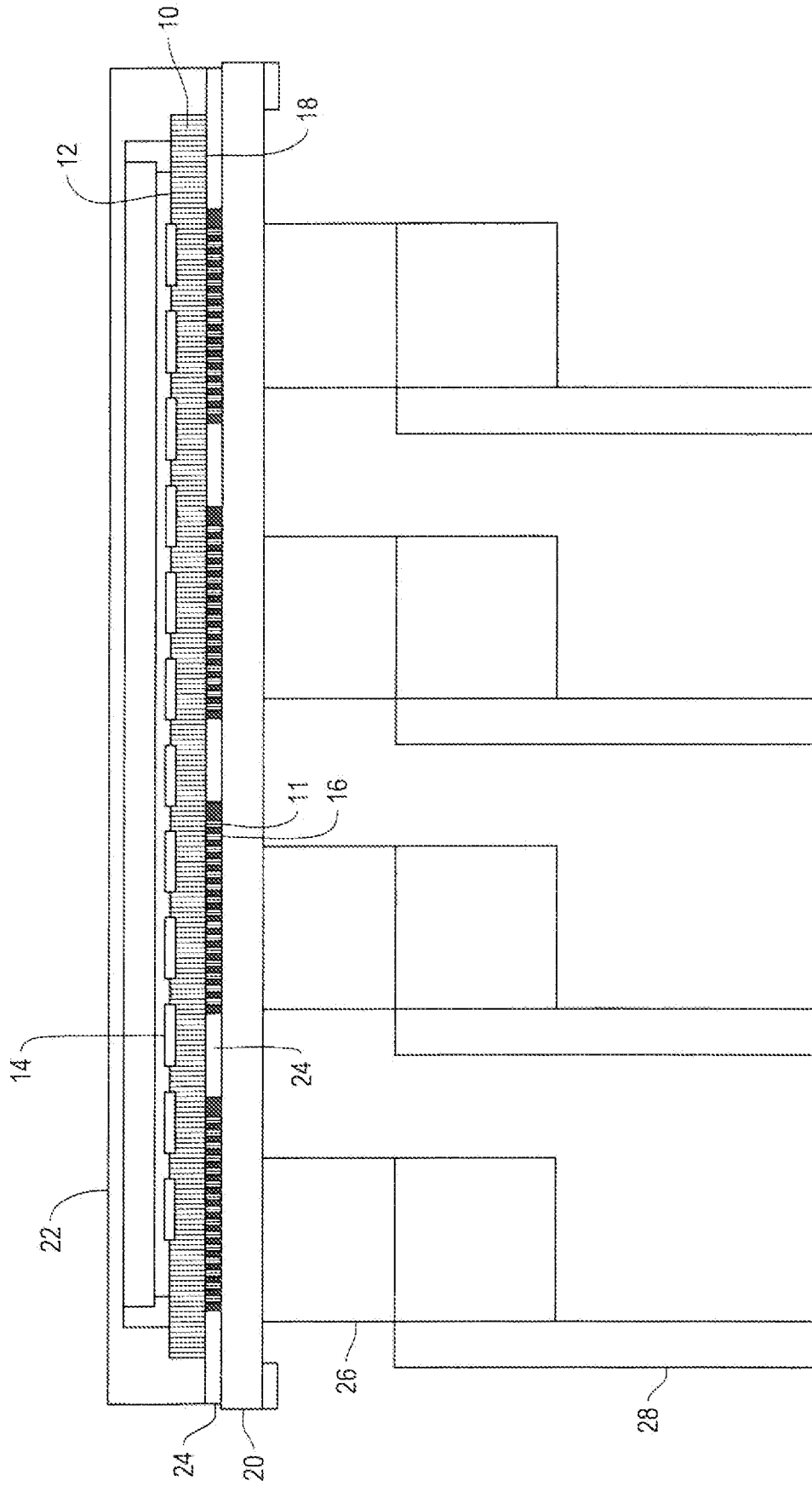

FIG. 1

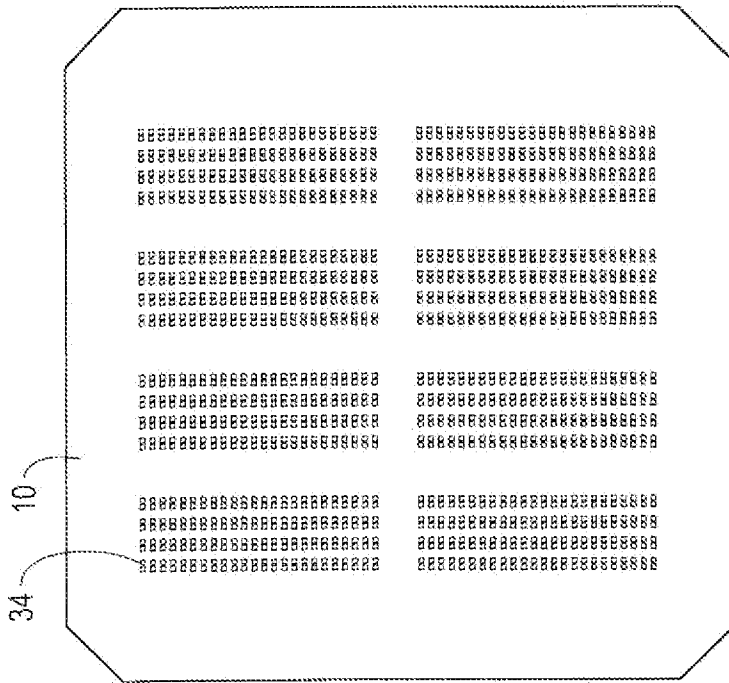

FIG. 2B

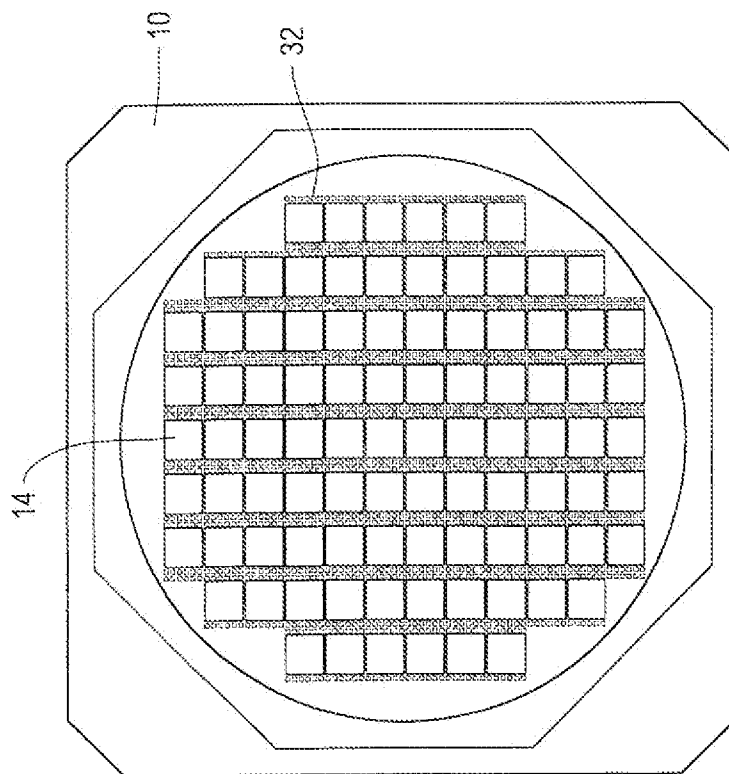

FIG. 2A

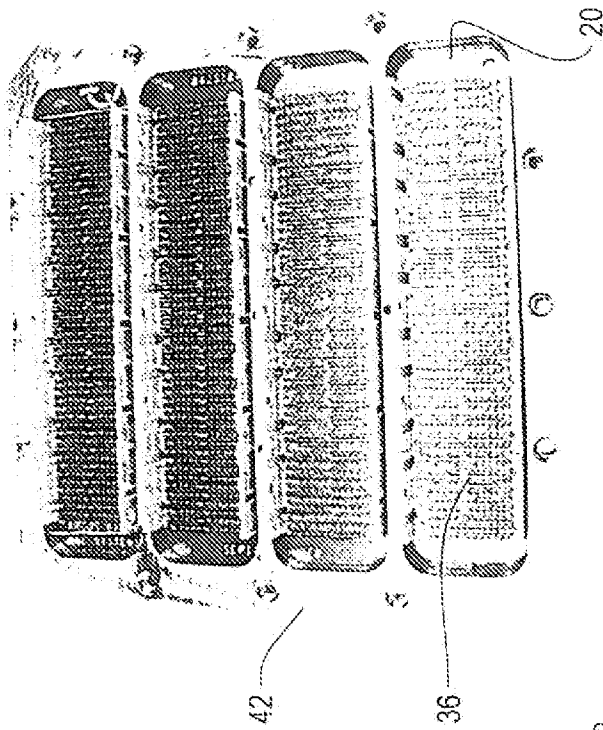

FIG. 3B

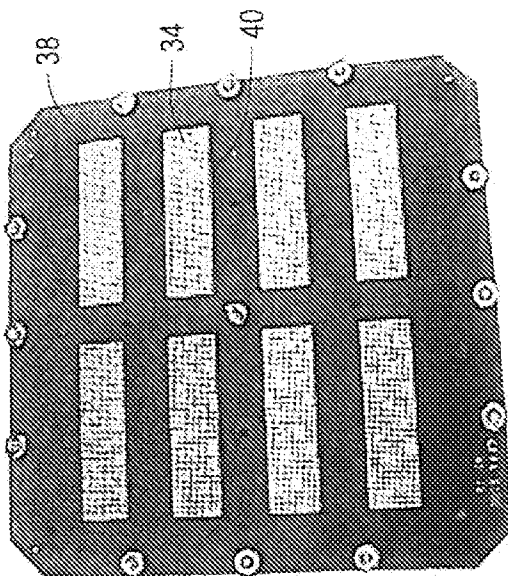

FIG. 3A

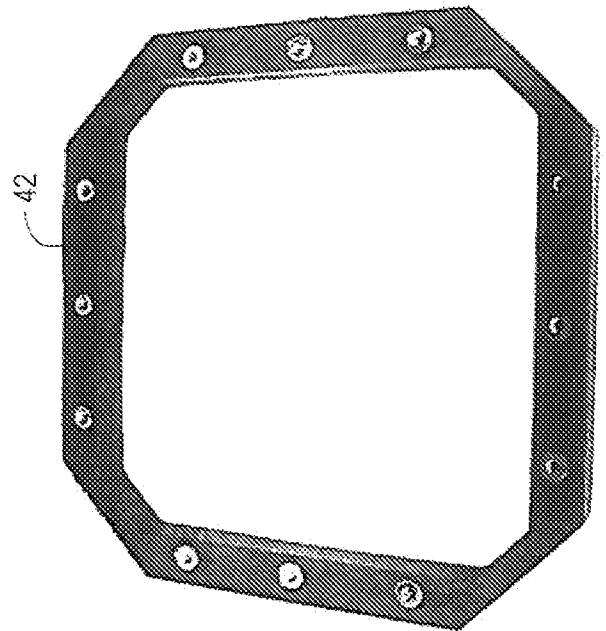

FIG. 3C

4/8

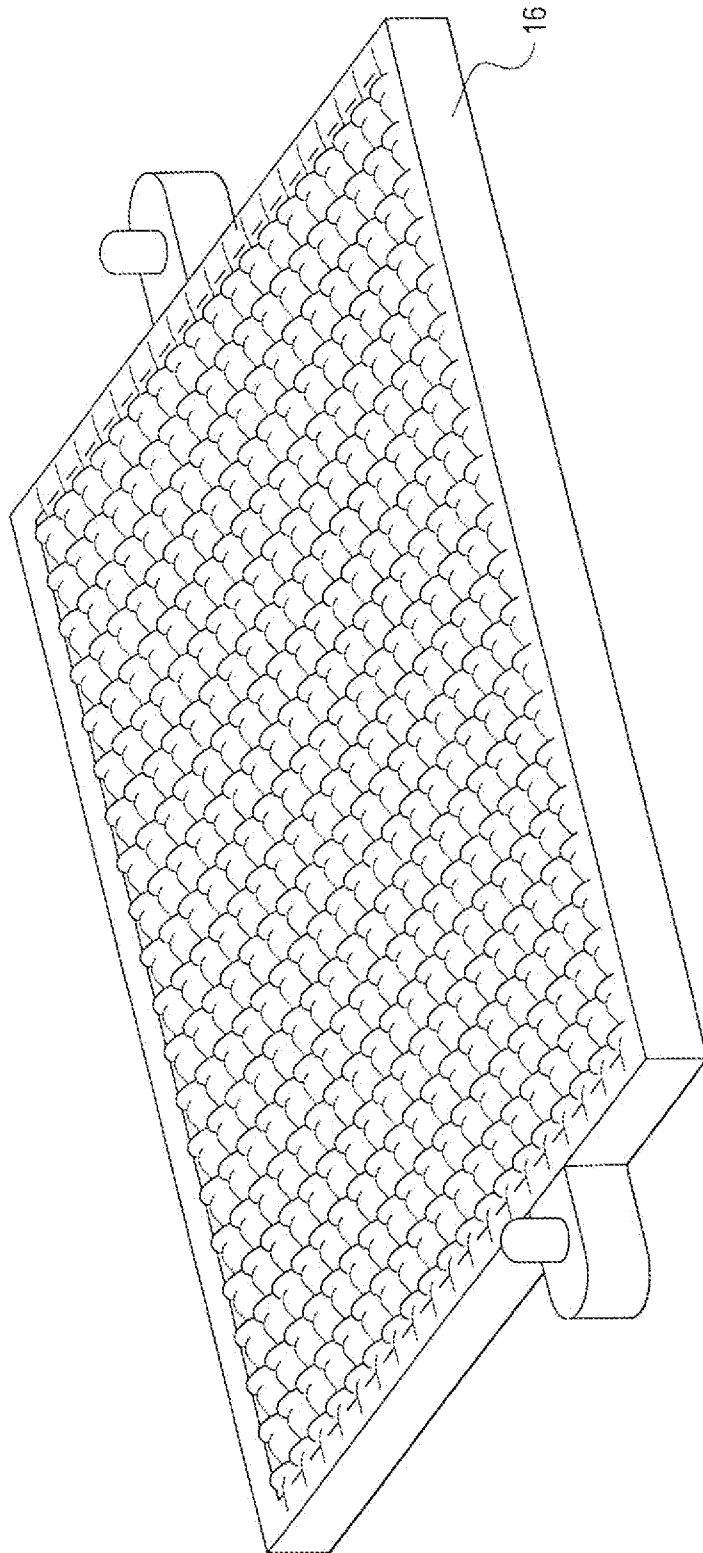

FIG. 4

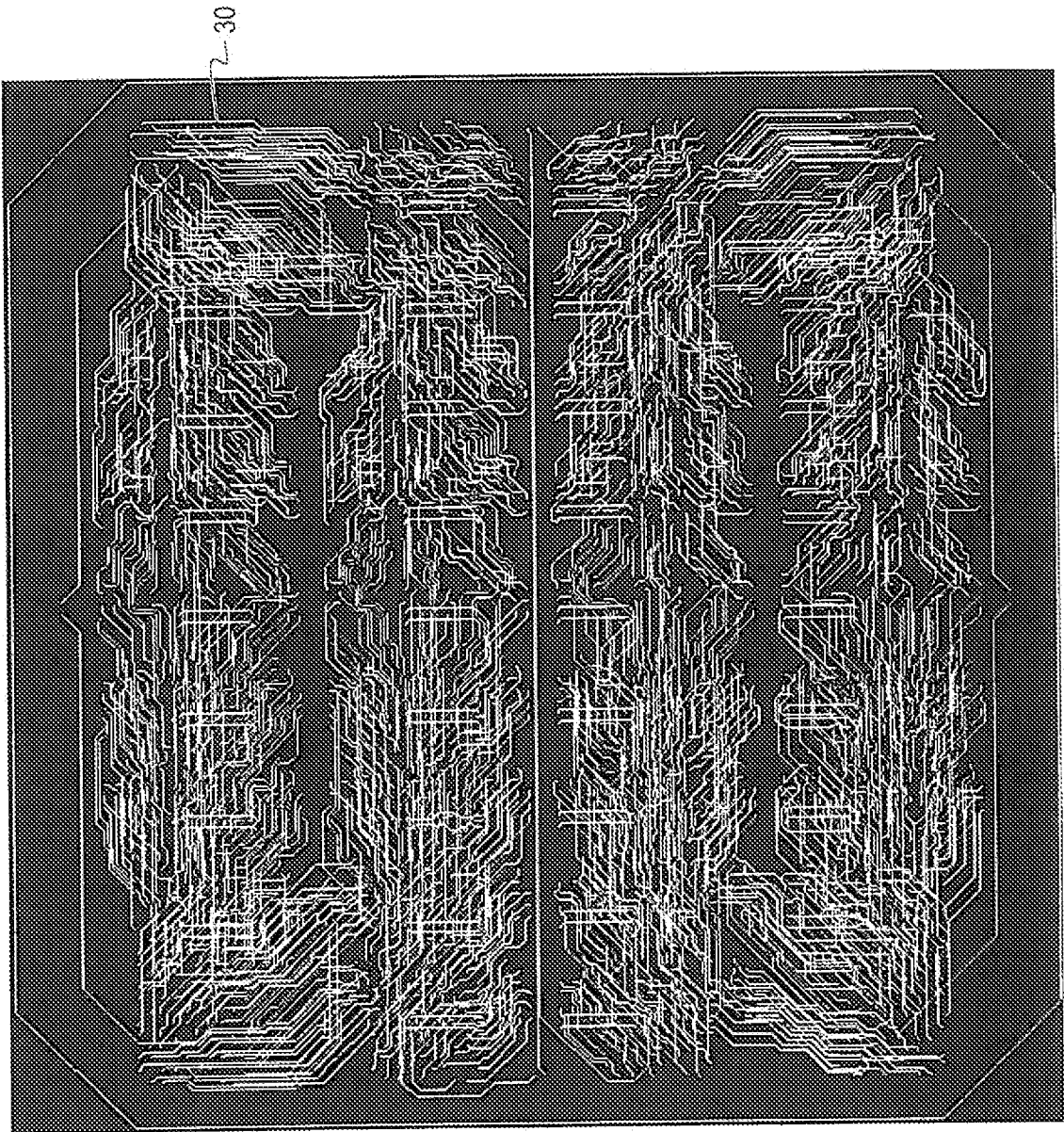

FIG. 5

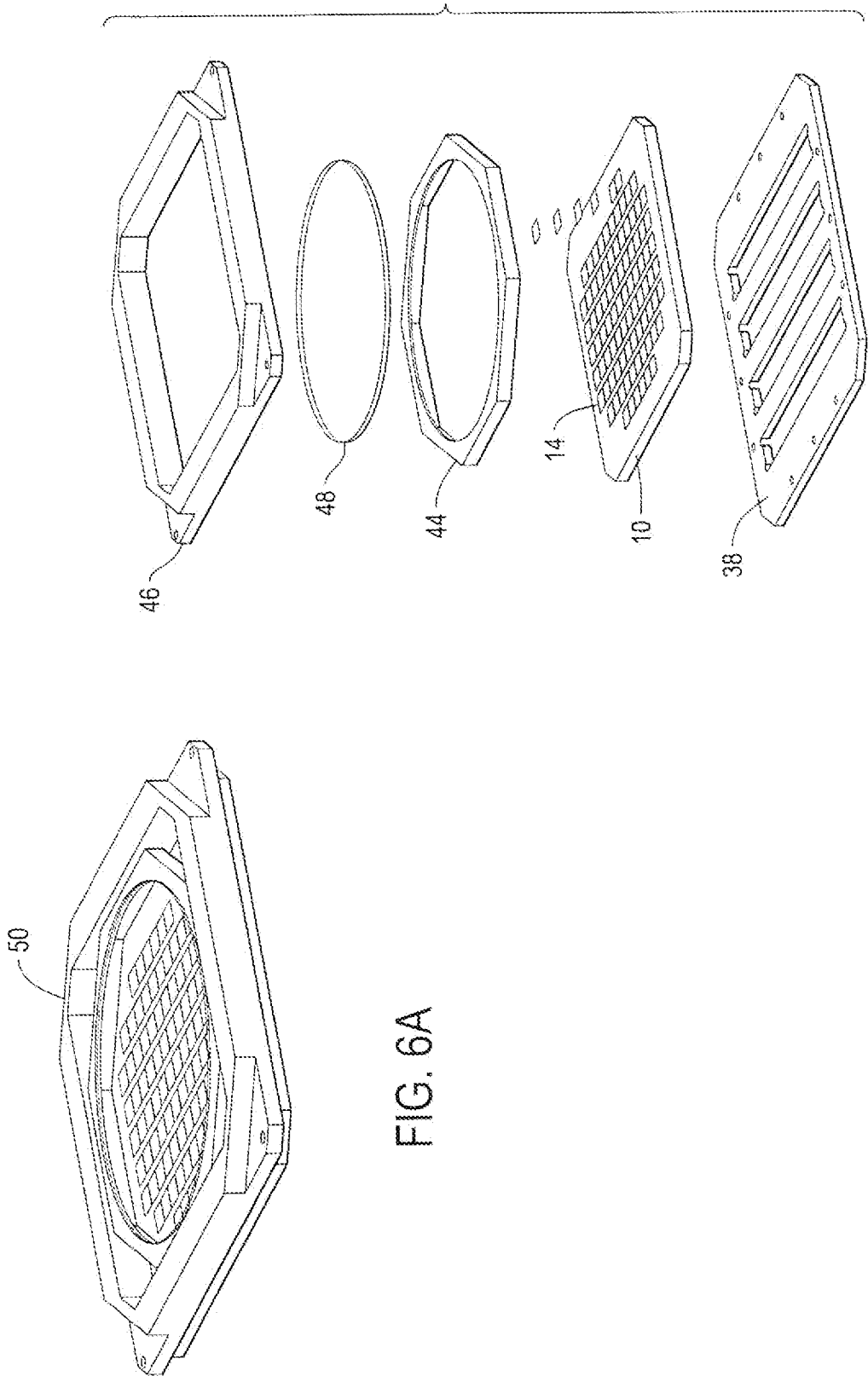

FIG. 6B

FIG. 6A

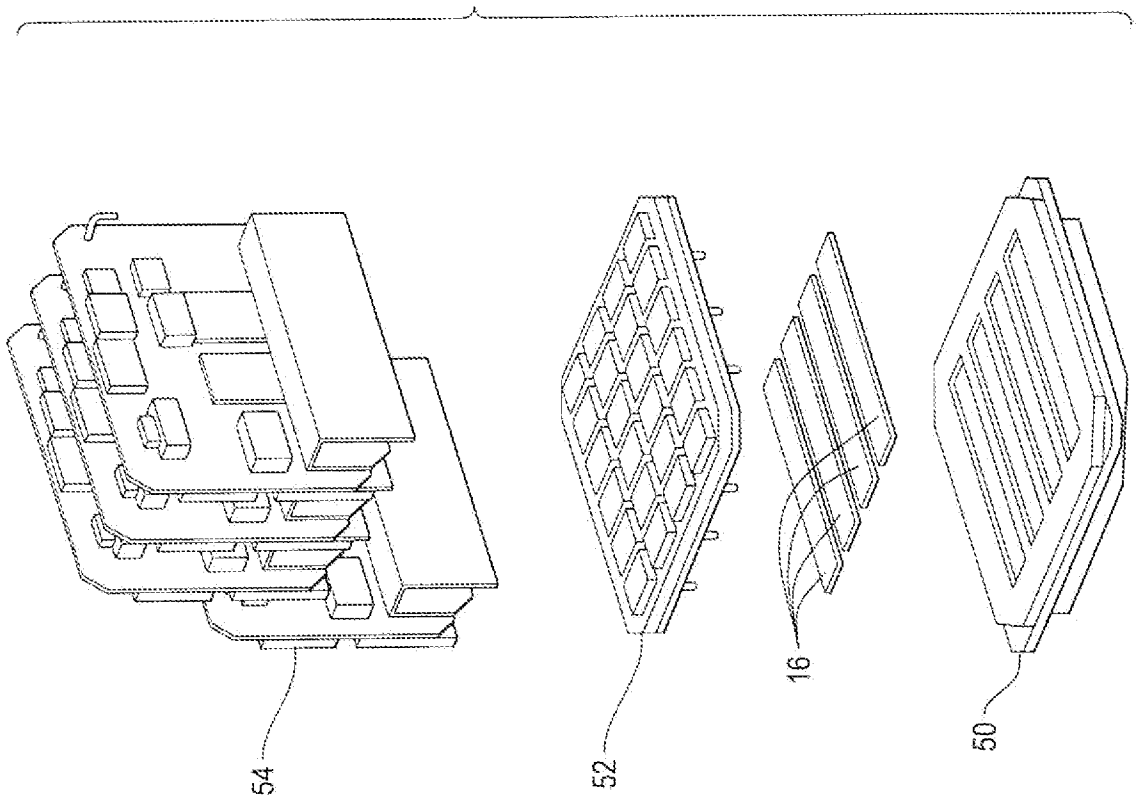

FIG. 7

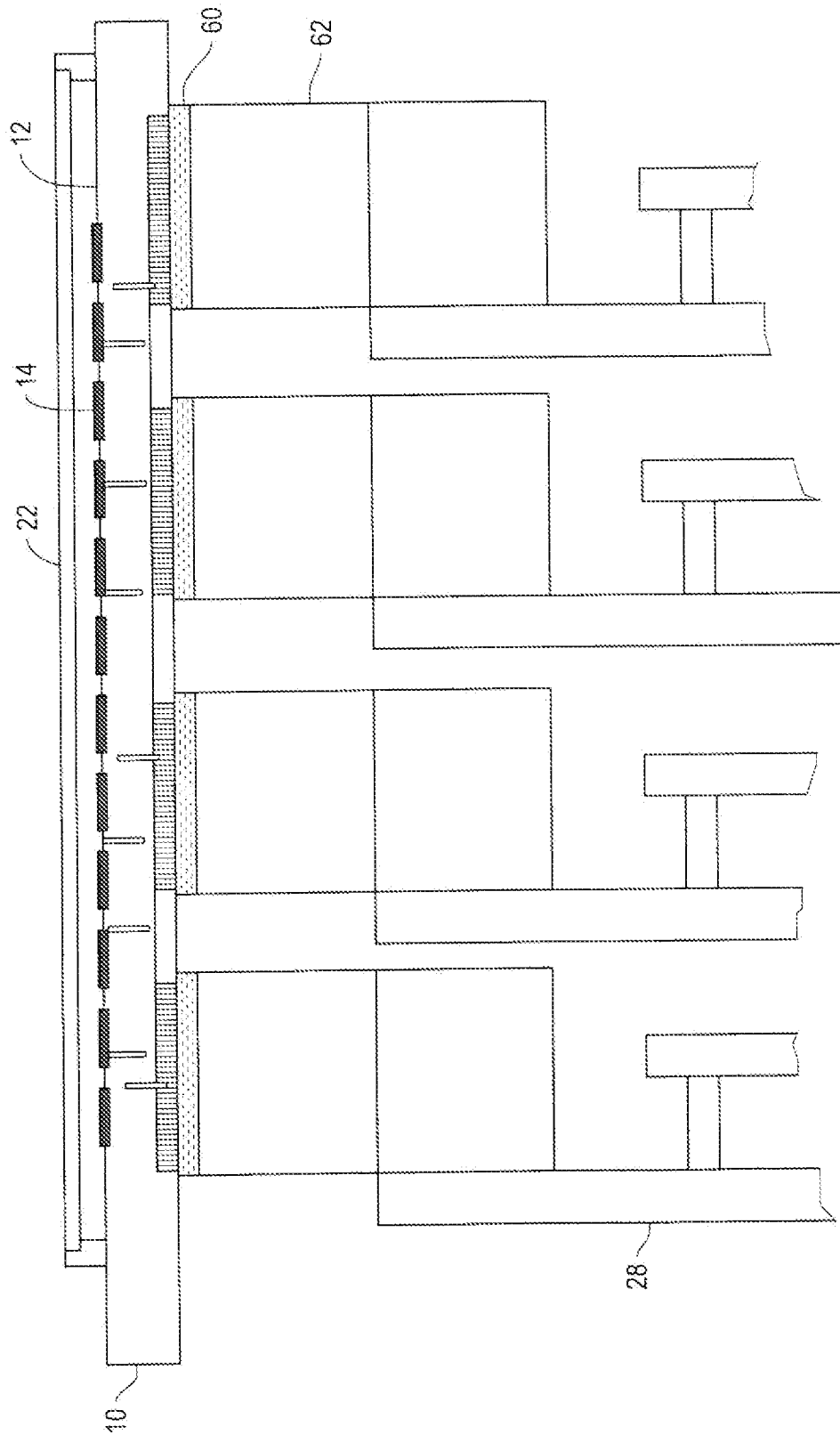

FIG. 8

INTERNATIONAL SEARCH REPORT

International application No.

PCT/US2009/063857

<p>A. CLASSIFICATION OF SUBJECT MATTER IPC(8) - H01L 27/14 (2010.01) USPC - 257/332 According to International Patent Classification (IPC) or to both national classification and IPC</p>																													
<p>B. FIELDS SEARCHED</p> <p>Minimum documentation searched (classification system followed by classification symbols) IPC(8) - H01L 27/14; G01J 5/08, 5/14; (2010.01) USPC - 257/332, 349, 692, 700, 703, 706, 707; 250/352</p> <p>Documentation searched other than minimum documentation to the extent that such documents are included in the fields searched</p> <p>Electronic data base consulted during the international search (name of data base and, where practicable, search terms used) PatBase, Google Patent</p>																													
<p>C. DOCUMENTS CONSIDERED TO BE RELEVANT</p> <table border="1"> <thead> <tr> <th>Category*</th> <th>Citation of document, with indication, where appropriate, of the relevant passages</th> <th>Relevant to claim No.</th> </tr> </thead> <tbody> <tr> <td>X ----- Y</td> <td>US 5,075,201 A (KOH) 24 December 1991 (24.12.1991) entire document</td> <td>22 ----- 1-8, 12, 16</td> </tr> <tr> <td>Y</td> <td>US 4,943,491 A (NORTON et al) 24 July 1990 (24.07.1990) entire document</td> <td>1-8, 19-20</td> </tr> <tr> <td>Y</td> <td>US 5,554,847 A (SALVIO et al) 10 September 1996 (10.09.1996) entire document</td> <td>2, 9-11, 13-21</td> </tr> <tr> <td>Y</td> <td>US 4,724,283 A (SHIMADA et al) 09 February 1988 (09.02.1988) entire document</td> <td>3-4, 6, 9-21</td> </tr> <tr> <td>Y</td> <td>US 7,213,940 B1 (VAN DE VEN et al) 08 May 2007 (08.05.2007) entire document</td> <td>7, 11</td> </tr> <tr> <td>Y</td> <td>US 6,824,396 B2 (KOOPMAN et al) 30 November 2004 (30.11.2004) entire document</td> <td>14</td> </tr> <tr> <td>Y</td> <td>US 6,693,664 B2 (NEUMANN) 17 February 2004 (17.02.2004) entire document</td> <td>18</td> </tr> <tr> <td>A</td> <td>US 5,308,980 A (BARTON) 03 May 1994 (03.05.1994) entire document</td> <td>22</td> </tr> </tbody> </table>			Category*	Citation of document, with indication, where appropriate, of the relevant passages	Relevant to claim No.	X ----- Y	US 5,075,201 A (KOH) 24 December 1991 (24.12.1991) entire document	22 ----- 1-8, 12, 16	Y	US 4,943,491 A (NORTON et al) 24 July 1990 (24.07.1990) entire document	1-8, 19-20	Y	US 5,554,847 A (SALVIO et al) 10 September 1996 (10.09.1996) entire document	2, 9-11, 13-21	Y	US 4,724,283 A (SHIMADA et al) 09 February 1988 (09.02.1988) entire document	3-4, 6, 9-21	Y	US 7,213,940 B1 (VAN DE VEN et al) 08 May 2007 (08.05.2007) entire document	7, 11	Y	US 6,824,396 B2 (KOOPMAN et al) 30 November 2004 (30.11.2004) entire document	14	Y	US 6,693,664 B2 (NEUMANN) 17 February 2004 (17.02.2004) entire document	18	A	US 5,308,980 A (BARTON) 03 May 1994 (03.05.1994) entire document	22
Category*	Citation of document, with indication, where appropriate, of the relevant passages	Relevant to claim No.																											
X ----- Y	US 5,075,201 A (KOH) 24 December 1991 (24.12.1991) entire document	22 ----- 1-8, 12, 16																											
Y	US 4,943,491 A (NORTON et al) 24 July 1990 (24.07.1990) entire document	1-8, 19-20																											
Y	US 5,554,847 A (SALVIO et al) 10 September 1996 (10.09.1996) entire document	2, 9-11, 13-21																											
Y	US 4,724,283 A (SHIMADA et al) 09 February 1988 (09.02.1988) entire document	3-4, 6, 9-21																											
Y	US 7,213,940 B1 (VAN DE VEN et al) 08 May 2007 (08.05.2007) entire document	7, 11																											
Y	US 6,824,396 B2 (KOOPMAN et al) 30 November 2004 (30.11.2004) entire document	14																											
Y	US 6,693,664 B2 (NEUMANN) 17 February 2004 (17.02.2004) entire document	18																											
A	US 5,308,980 A (BARTON) 03 May 1994 (03.05.1994) entire document	22																											
<p><input type="checkbox"/> Further documents are listed in the continuation of Box C. <input type="checkbox"/></p>																													
<p>* Special categories of cited documents:</p> <table border="0"> <tr> <td style="vertical-align: top;"> <p>"A" document defining the general state of the art which is not considered to be of particular relevance</p> <p>"E" earlier application or patent but published on or after the international filing date</p> <p>"L" document which may throw doubts on priority claim(s) or which is cited to establish the publication date of another citation or other special reason (as specified)</p> <p>"O" document referring to an oral disclosure, use, exhibition or other means</p> <p>"P" document published prior to the international filing date but later than the priority date claimed</p> </td> <td style="vertical-align: top;"> <p>"T" later document published after the international filing date or priority date and not in conflict with the application but cited to understand the principle or theory underlying the invention</p> <p>"X" document of particular relevance; the claimed invention cannot be considered novel or cannot be considered to involve an inventive step when the document is taken alone</p> <p>"Y" document of particular relevance; the claimed invention cannot be considered to involve an inventive step when the document is combined with one or more other such documents, such combination being obvious to a person skilled in the art</p> <p>"&" document member of the same patent family</p> </td> </tr> </table>			<p>"A" document defining the general state of the art which is not considered to be of particular relevance</p> <p>"E" earlier application or patent but published on or after the international filing date</p> <p>"L" document which may throw doubts on priority claim(s) or which is cited to establish the publication date of another citation or other special reason (as specified)</p> <p>"O" document referring to an oral disclosure, use, exhibition or other means</p> <p>"P" document published prior to the international filing date but later than the priority date claimed</p>	<p>"T" later document published after the international filing date or priority date and not in conflict with the application but cited to understand the principle or theory underlying the invention</p> <p>"X" document of particular relevance; the claimed invention cannot be considered novel or cannot be considered to involve an inventive step when the document is taken alone</p> <p>"Y" document of particular relevance; the claimed invention cannot be considered to involve an inventive step when the document is combined with one or more other such documents, such combination being obvious to a person skilled in the art</p> <p>"&" document member of the same patent family</p>																									
<p>"A" document defining the general state of the art which is not considered to be of particular relevance</p> <p>"E" earlier application or patent but published on or after the international filing date</p> <p>"L" document which may throw doubts on priority claim(s) or which is cited to establish the publication date of another citation or other special reason (as specified)</p> <p>"O" document referring to an oral disclosure, use, exhibition or other means</p> <p>"P" document published prior to the international filing date but later than the priority date claimed</p>	<p>"T" later document published after the international filing date or priority date and not in conflict with the application but cited to understand the principle or theory underlying the invention</p> <p>"X" document of particular relevance; the claimed invention cannot be considered novel or cannot be considered to involve an inventive step when the document is taken alone</p> <p>"Y" document of particular relevance; the claimed invention cannot be considered to involve an inventive step when the document is combined with one or more other such documents, such combination being obvious to a person skilled in the art</p> <p>"&" document member of the same patent family</p>																												
<p>Date of the actual completion of the international search 28 December 2009</p>		<p>Date of mailing of the international search report 11 JAN 2010</p>																											
<p>Name and mailing address of the ISA/US Mail Stop PCT, Attn: ISA/US, Commissioner for Patents P.O. Box 1450, Alexandria, Virginia 22313-1450 Facsimile No. 571-273-3201</p>		<p>Authorized officer: Blaine R. Copenheaver PCT Helpdesk: 571-272-4300 PCT OSP: 571-272-7774</p>																											