



(43) International Publication Date
15 November 2012 (15.11.2012)

- (51) International Patent Classification:
B65B 61/18 (2006.01) *B65D 83/00* (2006.01)
B05C 17/005 (2006.01)
- (21) International Application Number:
PCT/EP2012/058794
- (22) International Filing Date:
11 May 2012 (11.05.2012)
- (25) Filing Language: English
- (26) Publication Language: English
- (30) Priority Data:
11003881.7 11 May 2011 (11.05.2011) EP
11008107.2 6 October 2011 (06.10.2011) EP
- (71) Applicant (for all designated States except US): **POLY-CLIP SYSTEM GMBH & CO. KG** [DE/DE]; Niedeckerstrasse 1, 65795 Hattersheim (DE).
- (72) Inventors; and
- (75) Inventors/Applicants (for US only): **HANTEN, Jürgen** [DE/DE]; Am Ölberg 9, 61231 Bad Nauheim (DE). **NIEDECKER, Francesco** [CH/CH]; Via San Francesco 12, CH-6948 Porza (CH).
- (74) Agent: **EISENFÜHR SPEISER & PARTNER**; Postfach 31 02 60, 80102 München (DE).

- (81) Designated States (unless otherwise indicated, for every kind of national protection available): AE, AG, AL, AM, AO, AT, AU, AZ, BA, BB, BG, BH, BR, BW, BY, BZ, CA, CH, CL, CN, CO, CR, CU, CZ, DE, DK, DM, DO, DZ, EC, EE, EG, ES, FI, GB, GD, GE, GH, GM, GT, HN, HR, HU, ID, IL, IN, IS, JP, KE, KG, KM, KN, KP, KR, KZ, LA, LC, LK, LR, LS, LT, LU, LY, MA, MD, ME, MG, MK, MN, MW, MX, MY, MZ, NA, NG, NI, NO, NZ, OM, PE, PG, PH, PL, PT, QA, RO, RS, RU, RW, SC, SD, SE, SG, SK, SL, SM, ST, SV, SY, TH, TJ, TM, TN, TR, TT, TZ, UA, UG, US, UZ, VC, VN, ZA, ZM, ZW.
- (84) Designated States (unless otherwise indicated, for every kind of regional protection available): ARIPO (BW, GH, GM, KE, LR, LS, MW, MZ, NA, RW, SD, SL, SZ, TZ, UG, ZM, ZW), Eurasian (AM, AZ, BY, KG, KZ, RU, TJ, TM), European (AL, AT, BE, BG, CH, CY, CZ, DE, DK, EE, ES, FI, FR, GB, GR, HR, HU, IE, IS, IT, LT, LU, LV, MC, MK, MT, NL, NO, PL, PT, RO, RS, SE, SI, SK, SM, TR), OAPI (BF, BJ, CF, CG, CI, CM, GA, GN, GQ, GW, ML, MR, NE, SN, TD, TG).

Published:

- with international search report (Art. 21(3))
- before the expiration of the time limit for amending the claims and to be republished in the event of receipt of amendments (Rule 48.2(h))

(54) Title: ASSEMBLING APPARATUS, ASSEMBLING METHOD AND PACKAGING COMBINATION

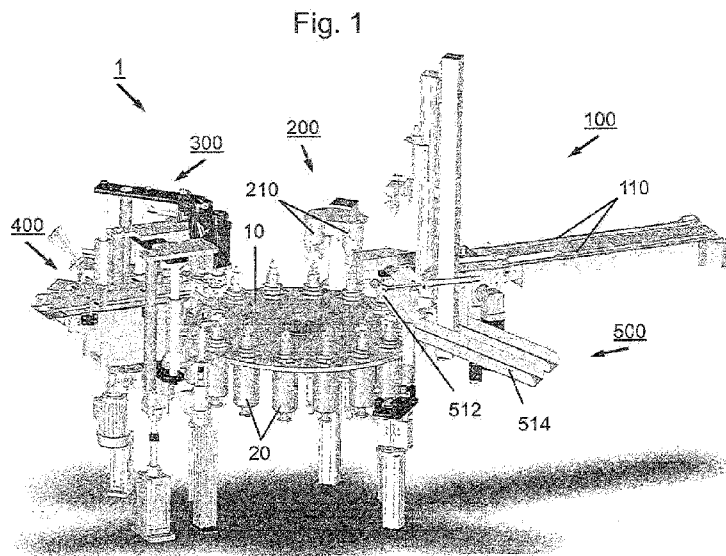

(57) Abstract: The present invention relates to an apparatus and a method for assembling a packaging combination (600) including a tubular casing (610) having a first end (612) and a second end (614), wherein the tubular casing (610) is partially filled with filling material and closed at its first as well as its second end (612, 614) by a closure means (C), like a closure clip, and wherein the partially filled tubular casing (610) comprises a plait-like portion (P) at its first end (32) being at least approximately free of filling material, and further including a dispensing device (620) having a passageway extending through the dispensing device (620) with an inlet opening at its one end and a dispensing opening at its other end for guiding and dispensing the filling material in a dispensing direction. The apparatus (1) comprises at least one supporting means (10, 20) for accommodating and retaining the at least partially filled tubular casing (610), including at least one cartridge (20) for arranging the at least partially filled tubular casing (610); at least one shaping means (210) for creating a defined

shape to the first end (612) of the tubular casing (610), including at least one gripper means (230) for gripping the first end of the at least partially filled tubular casing (610) and at least one forming shoulder (220) for forming a defined shape to the said first end (612); and at least one mounting means (310) for mounting the dispensing device (620) to said first end (612) of the tubular casing (610). The present invention further relates to packaging combination (1) comprising a tubular casing (610), a dispensing device (620) and a sealing device (630) is removably attached to the dispensing device (620).

Assembling apparatus, assembling method and packaging combination

The present invention relates to an apparatus for assembling a packaging combination including a tubular casing and a dispensing device according to claim 1. The present invention further relates to a method for assembling said packaging combination according to independent claim 12. Moreover, the present invention
5 relates to a packaging combination for accommodating and dispensing a viscous or granular filling material according to claim 16 as well as to a dispensing device according to claim 22 for being attached to a tubular casing and a partially filled tubular casing according to claim 23 to which a dispensing device may be attached.

10 From EP patent application 1 988 032, a tubular or sausage-shaped packaging is known, being filled with sausage meat. The sausage-shaped product is produced by closing a tubular casing at one end, filling the sausage meat into said tubular casing and closing the filled tubular casing at its respective other end. In order to allow an easier opening of the sausage-shaped product, perforation lines including
15 a number of weak locations are provided on the casing, along which the casing may be opened by pulling off the casing material and dispensing the sausage meat.

Furthermore, packing combinations including a tubular casing packing and a dispensing device are known, e.g. from German laid open document 38 31 225, wherein a device for dispensing the filling material stored in a tubular or bag-shaped packing is disclosed. The device includes a rigid tube having a dispensing nozzle at its one end and being provided for containing completely a bag-shaped casing. The bag-shaped casing containing a pasty filling material, like an adhesive, has to be opened at one end and has then to be positioned in said rigid tube with its opened end facing the dispensing nozzle. A piston matching the inner diameter of the tube is thereafter pushed into the tube, thereby squeezing the bag-shaped packaging and dispensing the filling material through the dispensing nozzle.

With this known packaging combination, it is of disadvantage that the rigid tube has outer circumferential dimensions being such that the complete bag-shaped casing can be accommodated in said rigid tube. If this known packaging combination is provided as a disposable device, this solution is expensive due to the big rigid tube being made from relatively expensive plastics. If this known packaging combination used such that only bag-shaped casing is thrown away and the rigid tube is used several times, the bag-shaped casing must be opened outside the tube so that, when the opened bag-shaped casing is introduced in the rigid tube, filling material can accidentally discharged and can pollute the environment.

The assembling of said known tubular casing and dispensing device to a packaging combination on one hand is cost and time expensive, since said assembling has to be made by hand. Moreover, in case that the dispensing device has to be reused, it has to be cleaned from the filling material, which comes into contact at least with the dispensing nozzle. On the other hand, in case that said packaging combination shall be used as a disposable packaging combination, a large amount of material, in particular the rigid tube is wasted, causing high costs.

Thus, it is an object of the present invention to provide an apparatus and a method with which a packaging combination can automatically and time and cost efficient may be assembled. Furthermore, it is an object of the present invention to provide a packaging combination producible on said assembling apparatus

with which the above mentioned drawbacks have been overcome, and which allows an easy and save opening of the tubular casing.

According to the present invention, there is provided an apparatus for assembling a packaging combination which includes a tubular casing having a first end and a second end, wherein the tubular casing is partially filled with filling material and closed at its first as well as its second end by a closure means, like a closure clip, and wherein the partially filled tubular casing comprises a plait-like portion at its first end being at least approximately free of filling material. The packaging assembly further includes a dispensing device having a passageway extending through the dispensing device with an inlet opening at its one end and a dispensing opening at its other end for guiding and dispensing the filling material in a dispensing direction. The inventive apparatus comprises at least one supporting means for accommodating and retaining the at least partially filled tubular casing, including at least one cartridge for arranging the at least partially filled tubular casing in the assembling apparatus. The apparatus further includes at least one shaping means for creating a defined shape to the first end of the tubular casing, including at least one gripper means for gripping the first end of the at least partially filled tubular casing and at least one forming shoulder for forming a defined shape to the said first end and at least one mounting means for mounting the dispensing device to said first end of the tubular casing.

The at least partially filled tubular casing is preferably vertically arranged in the assembling apparatus by means of said cartridge. Naturally, in order to form a defined shape to the first end and to mount a dispensing device thereto, the at least partially filled tubular casing may also be provided in a horizontal alignment or in any other suitable angle.

With the inventive apparatus, a packaging combination including a tubular casing and a dispensing device may automatically be assembled without the need of manpower and manual work, whereby a large amount of time and costs may be saved.

In a preferred embodiment of the inventive assembling apparatus, the cartridge is coupled with a drive means for moving said cartridge, whereby the tubular casing may be accurately be positioned to be processed.

The drive means for the cartridge may be of any suitable kind, like an electrical or pneumatically drive. In advantageous configuration, the drive means include a piston/cylinder assembly.

In a further advantageous embodiment, the forming shoulder of the shaping means is a shaping ring having an inner surface corresponding to the shape to be created of the first end of the tubular casing. Said shaping ring facilitates an easy and reliable forming of a defined shape to said first end of the tubular casing. Thereby, said shaping ring may be provided as a single part, but also may be composed of a number of segments.

To ensure a save and reliable gripping of the first end of the tubular casing, the gripper means of the shaping means include at least one claw for gripping said first end of the tubular casing. By using said gripper claws, a gripping force may be adjusted, dependent on the kind of the packaging material, for avoiding damages of sad casing material or the closing means. In another embodiment, the gripper means can be formed by a suction device which sucks in the first and of the tubular casing. Moreover, any other device for providing a "gripping force" to "grip" and hold the first end of the tubular casing can be used.

For creating a defined shape to the first end of the tubular casing, advantageously, the shaping means and/or the gripper means include a drive means for reversible moving the shaping means and the gripper means relative to each other.

The assembling apparatus according to the present invention can comprise receiving means for receiving the partially filled tubular casing. By means of said receiving means which may be a conventionally conveyor, the apparatus may be coupled to a clipping machine in which said tubular casing can be produced. In this case, it is possible to control the assembling apparatus on the basis of a signal from said clipping machine.

For automatically and defined providing the dispensing device to be mounted to the tubular casing, the apparatus comprises receiving means for receiving the dispensing device.

5 In order to prevent the filling material in the packaging combination from being contaminated or escaped, a closure cap may be attached to said packaging combination. Additionally or alternatively, for an easy and accurate dispensing of the filling material, also a dispensing nozzle may be provided. Accordingly, in an advantageous configuration, the assembling apparatus comprises attachment means for attaching a closure cap and or a dispensing nozzle to the dispensing
10 device.

In a preferred embodiment of the inventive apparatus, at least the supporting means, the shaping means and the mounting means are arranged in work stations to enable an efficient assembling of the tubular casing and the dispensing device.

15 Moreover, there is provided a method for assembling a packaging combination including a tubular casing having a first end and a second end, wherein the tubular casing is partially filled with filling material and closed at its first as well as its second end by a closure means, like a closure clip, and wherein the partially filled tubular casing comprises a plait-like portion at its first end being at least approx-
20 imately free of filling material. The packaging combination further includes a dispensing device having a passageway extending through the dispensing device with an inlet opening at its one end and a dispensing opening at its other end for guiding and dispensing the filling material in a dispensing direction. The method comprises the steps of accommodating and retaining the at least partially filled
25 tubular casing, positioning a forming shoulder at the first end of the tubular casing, gripping the first end of the tubular casing, forming a defined shape to the first end of said tubular casing by moving the tubular casing and the forming shoulder relative to each other, and mounting a dispensing device to said first end of said tubular casing.

According to the present invention, the method further comprises, not necessarily in this order, the steps of receiving the at least partially filled tubular casing, moving the at least partially filled tubular casing between working stations including at least the supporting means, the shaping means and the mounting means, and
5 attaching a closure cap and a dispensing nozzle to the dispensing device.

The inventive method thereby provides the same advantages as disclosed in conjunction with the inventive assembling apparatus. With the inventive assembly apparatus as well as method, it is possible to assemble packaging combination with a dispensing device the axial length of which is substantially shorter than the
10 axial length of the tubular casing. Thus, if such a packaging combination shall be used as a disposable packaging combination, the burden of the environment due to a bulky dispensing device, like in the prior art, is reduced.

Moreover, in accordance with the present invention, there is provided a packaging combination for accommodating and dispensing a viscous or granular filling
15 material, the packaging combination comprises a tubular casing having a first end and a second end, wherein the tubular casing is partially filled with filling material and closed at its second end by a closure means, like a closure clip, wherein the first end is at least approximately free of filling material. The packaging combination further comprises a dispensing device having a passageway extending
20 through the dispensing device with an inlet opening at its one end and a dispensing opening at its other end for guiding and dispensing the filling material in a dispensing direction. The dispensing device is attached to the first end of the partially filled tubular casing, wherein the first end extends inside the passageway of the dispensing device. At least a sealing element is removably attached to the
25 dispensing device for closing and sealing the dispensing opening of the dispensing device.

This configuration of a packaging combination enables a safe and easy opening of the tubular casing by removing the sealing element from the dispensing opening and dispensing the filling material just by squeezing the filled tubular casing
30 portion. Thus, an accidental discharge of filling material, while introducing the casing into a dispensing tube is prevented. Furthermore, the sealing device re-

movably attached to the dispensing device, allows an indication of the original closure of the packaging combination and an easy and clean opening of said packaging combination without the need of any opening tools.

In an advantageous embodiment of the packaging combination according to the present invention, the dispensing device includes at least a first and a second
5 portion, wherein the first portion extends from the inlet opening of the passage-way in the dispensing direction and the second portion extends from the dispensing opening opposite to the dispensing direction, and wherein the inner circumferential dimensions of the first portion corresponds at least approximately to the
10 outer circumferential dimensions of the tubular casing.

That means that the cross-section of the first portion of the dispensing device corresponds to the cross-section of the tubular casing, i.e. both, the first portion and the tubular casing, are of a circular cross-section, whereby the outer diameter of the tubular casing corresponds to the inner diameter of the first portion
15 of the dispensing device. This allows a form-fit attachment of the dispensing device to the filled tubular casing. The term "circumferential dimension" has not only to be understood as the sole circumference, but also as a dimension characterizing a cross-section, like the length or width of a rectangle, a side length of a triangle or a diameter of a circle. Naturally, the first portion of the dispensing device and
20 the tubular casing may be of any other suitable form, i.e. of a rectangular or triangular shape, the remarkable point is that their cross sections or circumferential dimensions correspond to each other.

According to the present invention, the packing combination includes a closure cap reversibly attachable to the dispensing device for releasing and closing the
25 dispensing opening. A reversibly attachable closure cap reliably prevents the filling material from unintentionally escaping from the packaging combination and further allows storing and reusing an opened packaging.

In a preferred constitution, an indicating unit for indicating the originality of the closure of the dispensing opening provided at the dispensing device. Alternative-
30 ly, the indicating unit may be attached to the closure cap. Said indicating unit

surely displays whether or not the inventive packaging combination has already been opened.

As mentioned above, the dispensing device is attached to the tubular casing for forming the inventive packaging combination. To avoid the dispensing device
5 from dropping off from the tubular casing, the dispensing device is secured to the first end of the tubular casing by an adhesive, in particular, by a hot-melt adhesive. Naturally, in case that sensitive filling materials are filled into the tubular casing, other adhesive means, like an adhesive tape, may be used, which e.g. may not be heated.

10 The object of the present invention may also be solved by a dispensing device for being attached to a tubular casing to form a packaging combination according to the invention described above.

In case that the dispensing device is provided as a disposable the amount material which has to be thrown away is remarkably reduced compared to the material
15 in the case of known packaging combinations as described previously. This will reduce costs for producing the packaging combination and will also protect the environment.

Moreover, the object of the present invention may further be reached by a tubular casing partially filled with a filling material and closed at its first as well as its
20 second end by a closure means, like a closure clip, for being combined with a dispensing device to form a packing combination according to the invention described above.

Further advantages and a preferred embodiment will be described in the following together with the drawings listed below. The expressions "left", "right", "below"
25 and "above" are referred to the drawings in an alignment such that the reference numbers used can be read in normal.

In the drawings:

- Fig. 1: is a schematically perspective view to an assembling apparatus according to the present invention;
- 5 Fig. 2: is a schematically cross-section of the shaping station of the assembling apparatus according to Fig. 1;
- Fig. 3: is a schematically perspective view to the mounting station of the assembling apparatus according to Fig. 1;
- Fig. 4: is a perspective view to a first embodiment of the packaging combination according to the present invention;
- 10 Fig. 5: is a longitudinal-section to the embodiment of the packaging combination of Fig. 4;
- Fig. 6: is a perspective view to a second embodiment of the packaging combination according to the present invention; and
- 15 Fig. 7: is a longitudinal-section to the embodiment of the packaging combination of Fig. 6.

Fig. 1 shows a schematically perspective view to an assembling apparatus 1 according to the present invention. The assembling apparatus 1 comprises a circular table 10, which holds supporting means 20 for accommodating and retaining a number of at least partially filled tubular casings while a dispensing device is mounted to each of said tubular casings. The apparatus further comprises a number of work stations 100, 200, 300, 400, 500, which are arranged around table 10 for processing tubular casings 30, when positioned in their working area.

20

Circular table 10 is horizontally arranged and supported to be rotatable about its vertically arranged central axis by a respective drive (not shown). Concentrically

25

to and along the outer edge of table 10 and at equal distances to each other, the supporting means in form of cartridges 20 are vertically arranged. As it can be seen from Fig. 2, each cartridge 20 includes a barrel 22 which has an inner diameter corresponding to the outer diameter of a filled tubular casing 610, and in
5 which said tubular casing 610 is form-fit accommodated. For transporting tubular casing 610 to the respective work station, table 10 is rotated counter-clockwise.

Work station 100 includes the receiving means for receiving a tubular casing 610. According to Fig. 1, said receiving means is formed by two parallel and horizontally arranged band conveyors 110 which both can deliver two tubular casings
10 610 to table 10 at the same time. It has to be understood, that in this case two cartridges 20 are positioned in working or receiving station 100 for receiving the tubular casings 30 just delivered.

In the next working station 200, counter-clockwise arranged beside receiving station 100 at table 10, the shaping means 210 are positioned at least approximately above cartridges 20 when positioned in working or shaping station 200.
15 Shaping station 200 includes two identical shaping means 210 for simultaneously creating a defined shape to the first ends of tubular casings 610.

Following shaping station 200 in counter-clockwise direction, a mounting station 300 is positioned at circular table 10, for mounting dispensing device 620 to
20 tubular casing 610 for forming a packaging combination 600. Even if not shown in detail, mounting station 300 includes feeding means for feeding dispensing device 620 to mounting station 300. Dispensing device 620, when delivered to mounting station 300, is already provided with an appropriate portion of adhesive G at one of its inner surfaces to be secured to tubular casing 610. In an alternative
25 embodiment, mounting station 300 may include a dispensing apparatus for dispensing an adhesive to dispensing device 620 immediately before mounting dispensing device 620 to tubular casing 610. In case that the adhesive is a hot-melt adhesive, mounting station 300 includes a respective heating device known in the art.

Assembling apparatus 1 according to the embodiment of Fig. 1 further includes an attachment station 400 for attaching a closure cap 640 and or a dispensing nozzle 650 to dispensing device 620 (see Fig. 6). In particular, the closure cap 640 for closing the dispensing opening of dispensing device 620, in a preferred
5 embodiment, includes an inner screw thread for being screwed to dispensing device 620, which has a respective outer screw thread. Together with the closure cap, the dispensing nozzle may be attached to dispensing device 620, e.g. by means of a latch which is secured to dispensing device 620 by the closure cap when screwed to dispensing device 620.

10 Further in a counter-clockwise direction, a discharge station 500 as a last work station is arranged at circular table 10. Discharge station 500 includes discharge means 510 in the form of a lifter arrangement 512 for lifting the packaging combination 600 consisting of tubular casing 610 and dispensing device 620 from cartridges 20, and a conveyor arrangement 514 including a chute for distributing
15 the packaging combination from assembling apparatus 1 for further treatment.

Assembling apparatus 1 further includes a sealing station (not shown in Fig. 1). Said sealing station is arranged at table 10 between mounting station 300 for mounting dispensing device 620 to tubular casing 610 and attachment station
20 400 for attaching a closure cap 640 and/or a dispensing nozzle 650 to dispensing device 620. The sealing station includes removing means for removing the closure clip C temporarily attached to plait-like portion P at first end 612 of tubular casing 610, and sealing means for sealing device 630 to a dispensing opening 628 of dispensing device 620. The removing means may be realized by respective gripping means for gripping the closing clip C at plait-like portion P and one
25 ore more cutting elements for cutting off said closure clip C from plait-like portion P.

Fig. 2 is a schematically cross-section of shaping station 200 of assembling apparatus 1 according to Fig. 1. Shaping station 200 includes two identical shaping means 210 each including a shaping ring 220, gripper claws 230 and drives
30 (not shown) for actuating and moving shaping ring 220 and claws 230 as described in detail below. As it can be seen in Fig. 2, shaping ring 220 consists of

two semicircular segments 220a, 220b. Alternatively, shaping ring 220 may also be formed as one element or may include more than two segments.

In shaping station according to Fig. 2, two cartridges 20 are positioned vertically below shaping means 210 and held by table 10 (not shown in Fig. 2). Each cartridge 20 includes an approximately cylindrical barrel 22, which is mounted to a cylinder 24 and vertically movable therein. A piston 26 is attached to the bottom section of barrel 22 and extends through the bottom of cylinder 24.

Below cartridge 20, a drive assembly Z including two identical drive elements in the form of a piston/cylinder combination is arranged to act on piston 26 in order to move barrel 22 together with tubular casing 610 upwardly, whereby the upper or first end 612 of tubular casing 610, including plait-like portion P, which is closed by closure clip C, is positioned in the working area of shaping means 210. Tubular casing 610 is positioned in barrel 22 with its lower or second end 614, which is also closed by a further closure clip C, directed downwardly. Between the bottom of barrel 22 and the second end 614 of tubular casing 610, a fitting element F is positioned, for adapting cartridge 20 to the length of tubular casing 610 which has to project from the upper edge of barrel 22 about a predetermined length. For handling e.g. a longer tubular casing than that shown in Fig. 2, a respectively shorter fitting element F is to be placed in barrel 22. In adaption to a different diameter of tubular casing 610, barrel 22 may be exchanged to one of a respectively other inner diameter.

Fig. 3 is a schematically perspective view to mounting station 300 of assembling apparatus 1 according to Fig. 1. Mounting station 300 includes two identical mounting means 310, each of which has a delivering device 320 for delivering a dispensing device 620 to the working area of the mounting means, and a gripper 330 for gripping dispensing device 620 provided by delivering device 320 and attaching said dispensing device 620 to the first end 612 of tubular casing 610 provided by a cartridge 20 (not shown). Delivering device 320 and gripper 330 comprise respective drives (not shown) for being moved when delivering and mounting dispensing device 620 to tubular casing 610. Delivering device 320 is horizontally arranged above gripper 330 and horizontally movable in order to

position dispensing device 620 vertically above gripper 330. Gripper 330 according to Fig. 3 is vertically movable and includes two claws for gripping dispensing device 620 provided by delivering device 330, when in an upper position, and for attaching said dispensing device 620 to the first end 612 of tubular casing 610
5 when moved downwardly.

Fig. 4 shows a perspective view to a first embodiment of the packaging combination 600 according to the present invention. The packaging combination 600 includes a sausage-shaped tubular casing 610 having a first end 612 and a second end 614, wherein second end 614 is closed by closure clips C, and a
10 dispensing device 620 attached to the first end of 612 of tubular casing 610. Tubular casing 610 has a central axis A extending through first end 612 and second end 614. Dispensing device 620 has a first portion 622 including an inlet opening 624 and a second portion 626 including an outlet or dispensing opening 628, thereby defining a dispensing direction D. As it further can be seen in Fig. 4,
15 dispensing opening 628 is closed by a sealing device 630. Sealing device 630 is formed by a flat material, like a plastic or metal foil, and has an approximately circular sealing portion 632 and an opening portion or strap 634. The diameter of sealing portion 632 corresponds at least approximately to the outer diameter of second portion 626 of dispensing device 620, and completely covers dispensing
20 opening 628. Opening portion or strap 634 is of an approximately semicircular shape and of a dimension, which allows pulling off sealing device 630 from dispensing device 620 only by hand without any additional opening tools. Sealing element 630 may be fixed to dispensing device 620 e.g. by a sealing process including a heat-sealing or a gluing process using a respective adhesive, like a
25 hot-melt or cold acting glue for fixing sealing element 630.

In the embodiment of packaging combination 600 according to Fig. 4, tubular casing 610 is of a circular cross-section. Accordingly, also dispensing device 620 is of a generally circular cross-section at least for the first portion 622. First portion 622 of dispensing device 620 has an inner and outer cylindrical shape having
30 an inner diameter which corresponds to the outer diameter of tubular casing 610. Second portion 26 which also has an inner and outer cylindrical shape, is directly coupled to first portion 622 in the dispensing direction D via an annular offset

625. First portion 622, annular offset 625 and second portion 626 are coaxially arranged to central axis A of tubular casing 610. Moreover, the axial length of dispensing device 620 is clearly shorter than the axial length of the tubular casing 610. Thereby, dispensing device 620 is preferably made of plastics.

5 Fig. 5 shows a longitudinal-section along central axis A of the embodiment of the packaging combination 600 of Fig. 4. As it can be seen in Fig. 5, the outer diameter of tubular casing 610 corresponds to the inner diameter of the first portion 622 of dispensing device 620. Annular offset 625 and first portion 622 are approximately rectangular aligned to each other, thereby forming a flange surrounding
10 the outer edge of first end 612 of tubular casing 610. Between inlet opening 624 and dispensing opening 628, there extends a passageway formed by the inner walls of the first and second portion 622, 626 of the dispensing device 620.

For fixedly attaching dispensing device 620 to tubular casing 610, an adhesive G, preferably a hot-melt adhesive or a glue, is disposed at the inside of the flange
15 formed by annular offset 625 and first portion 622. The amount of adhesive G is sufficient for at least approximately filling the gap between first end 612 of tubular casing 610, annular offset 625 and first portion 622 of dispensing device 620.

As it further can be seen in Fig. 5, plait-like portion P at the first end 612 of tubular casing 610, which is at least approximately free from filling material and which
20 has been formed in a known manner during filling and closing tubular casing 610, has a length that corresponds to the axial length of the second portion 626 of dispensing device 620. The length of plait-like portion P is at least equal to the axial length of the second portion 626 of dispensing device 620. Second end 612 and thus, plait-like portion P, is not closed by a closure clip C. Said closure clip C,
25 which has been closed first end 612 during the production of the partially filled tubular casing 610, has been removed after dispensing device 620 has been mounted thereto and immediately before sealing device 630 has been attached to dispensing opening 628 of dispensing device 620.

It has to be understood that, for attaching dispensing device 620 to first end 612
30 of tubular casing 610, the inner diameter of the second portion 626 of dispensing

device 620, forming the dispensing opening 628, has to be at least slightly larger than the outer diameter of the closed closure clip C attached to first end 612. Accordingly, plait-like portion P closed by a closure clip C, has a length sufficient to extend through dispensing device 620 via inlet opening 624 and dispensing opening 628 to enable closure clip C closing first end 612, project from dispensing opening 628 in the dispensing direction D in order to remove closure clip C from first end 612 and for subsequently attaching sealing device 630 to dispensing opening 628.

A second embodiment of packaging combination 600 is shown in Fig. 6. This packaging combination 600 includes the tubular casing 610 having a first end 612, a second end 614 as well as a plait-like portion P and the dispensing device 620 having a first portion 622 including an inlet opening 624 and a second portion 626 including an outlet opening 628, both known from the embodiment according to Figs. 4 and 5.

Additionally, the packaging combination 600 includes a closure cap 40 for closing dispensing opening 28 of dispensing device 20 and a dispensing nozzle 50 for being attached to the dispensing opening 28, in order to dispense a desired amount of filling material.

Closure cap 640 includes a cylindrical portion 642 having a first end 642a and a second end 642b and a conical portion 644 being attached to second end 642b of cylindrical portion 642. As it can be seen in Fig. 7, which is a longitudinal-section to the embodiment of the packaging combination 600 of Fig. 6, the inner diameter of cylindrical portion 642 corresponds to the outer diameter of second portion 626 of dispensing device 620. The axial length of cylindrical portion 642 is at least approximately equal to the axial length of second portion 626 of dispensing device 620. As it can be seen in Fig. 7, cylindrical portion 642 is slightly longer than portion 626 of dispensing device 20.

In order to reversibly attach and release closure cap 640 to or from dispensing device 620, in particular to or from second portion 626 of dispensing device 620, an inner screw thread is provided at the inner surface of cylindrical portion 642 of

closure cap 640, which matches with an outer screw thread provided at the outer surface of second portion 626 of dispensing device 620.

Closure cap 640 according to Figs. 6 and 7 further comprises a flat fin member 648 arranged in a plane extending through longitudinal axis A of tubular casing 610, when being attached to dispensing device 620. Flat fin member 648 is coupled to the outside of cylindrical portion 642 and conical portion 644, and includes an opening arranged above conical portion 644 in the dispensing direction D. Fin member 648 thereby forms a hanger. For an easier opening of closure cap 640, the outer surface of cylindrical portion 642 is provided with grooves extending parallel to axis A.

As it further can be seen in Fig. 7, dispensing opening is sealed by sealing device 630. Circular sealing portion 632 thereby entirely covers dispensing opening 628. Opening portion or strap 634, which is not visible in Fig. 7, has been folded to the outside of second portion 626 during attaching closure cap 640 to dispensing device 620.

As mentioned above, packaging combination 1 of Figs. 6 and 7 further includes dispensing nozzle 650. Dispensing nozzle 650 has a hollow cylindrical portion 652 and a hollow conical portion 654 coupled to cylindrical portion 652. At the inner surface of cylindrical portion 652, an inner screw thread is provided matching with outer screw thread of second portion 626 of dispensing device 620 for reversibly attaching dispensing nozzle 650 thereto. Hollow conical portion 654 is open at its one end, which is coupled to conical portion 654 and closed at its other end forming a tip. In order to allow filling material to be dispensed through dispensing nozzle 650, the tip has to be cut off. The size or diameter of the dispensing opening of nozzle 650 depends on the position of the cutoff at conical portion 654 of dispensing nozzle 650. Nozzle 650 further comprises a flap element 56 extending radially from cylindrical portion 652 and including a circular opening for securing dispensing nozzle 650 to second portion 626 of dispensing device 650.

The packaging combination 600 according to the present invention further comprises an indicating unit (not shown) for indicating the originality of the closure of the dispensing opening. Said indicating unit may have the form of a small sheet attached to the dispensing device 620, e.g. at the outside of annular offset 625
5 for being coupled with closure cap 640 when being closed for the first time. When opening originally closed packaging combination 600, the indicating unit is removed from closure cap 640 and/or from annular offset 625 of dispensing device 620, indicating that packaging combination 600 is not originally closed anymore, and further indicating, in case of the presence of a cutting element inside closure
10 cap 640, that tubular casing 610 is opened and that filling material may escape from packaging combination 600 when releasing closure cap 640. The indicating unit may also be originally attached to the closure cap 640 and may than be coupled to dispensing device 620 when being closed for the first time. Naturally, an indicating unit may also be attached to any other suitable part of the packaging
15 combination, where its possible to indicate the originality of the closure of the dispensing device or at least of the dispensing opening. Naturally, also sealing device 630 provides an indicating unit for indicating the originality of the closure of the dispensing opening when present at dispensing opening 628.

Adhesive G provided at the inside of the flange formed by annular offset 625 and
20 first portion 622 in order to secure dispensing device 620 to the first end 612 of tubular casing 610 has been described as being a hot-melt adhesive. Dependent on the material of tubular casing, which may be a suitable plastic foil or a natural material, the material of dispensing device 620, which is preferably made of plastic but also from any other suitable material, like a metal, the adhesive G may
25 also be an other than a hot-melt adhesive. E.g. in case of temperature sensitive filling materials or casing material, a cold acting adhesive is required.

For assembling a packaging combination 600 including a tubular casing 610 and a dispensing device 620, a tubular casing 610 is received by horizontally aligned
30 band conveyor 110 of receiving station 100. In receiving station 100, tubular casing 30 arranged horizontally on band conveyer 110 is transferred in a vertical position above cartridge 20 and placed in cartridge 20 with its first end 612 including plait-like portion P directed upwardly.

After positioning tubular casing 610 in cartridge 20, circular table 10 is rotated counter-clockwise about a predefined angle. Thereby, tubular casing 610 together with cartridge 20 is positioned in shaping station 200 below shaping means 210. In this position, shaping means 210, in particular claws 230 are in an opened position. Drive assembly D is actuated and moves cartridge 20 and tubular casing 30 upwardly in a position, in which first end 612 of tubular casing 610 is in the working area of shaping means 210. Thereafter, claws 230 will be closed for gripping first end 612 of tubular casing 610, in particular, closure clip C. Shaping ring 220 consisting of segments 220a, 220b, is positioned around and closely surrounds plat-like portion P. Shaping ring 220 is then moved down along plait-like portion P and away from claws 230, thereby creating a shape to the first end 612 of tubular casing 610, corresponding to the inner shape of shaping ring 220. Thereafter, shaping ring 220 is moved back towards claws 230 and away from plait-like portion P. Claws 230 are opened for releasing first end 612 of tubular casing 610, and cartridge 20 together with tubular casing 610 is shifted downwardly by drive assembly D.

Next, table 10 is rotated counter-clockwise for positioning cartridge 20 with tubular casing 610 having a defined shaped first end 612 in mounting station 300 below mounting means 310. In mounting station 300, a dispensing device 620 is provided by delivering device 320. Below delivering device 320, vertically movable gripper 330 is provided. In its upper position, gripper 330 grasps dispensing device 620 held by delivering device 320, and moves vertically downwardly towards first end 612 of tubular casing 610 provided by cartridge 20. Gripper 330 mounts dispensing device 620 to the first end 612 of tubular casing 610 by means of an adhesive G disposed at an inner surface of dispensing device 620 which comes into contact with the outer surface of tubular casing 610. Plait-like portion P thereby is guided through and extends beyond the dispensing opening 628 of dispensing device 620.

After moving gripper 330 in its opened position, table 10 further turns counter-clockwise for positioning cartridge 20 with tubular casing 610 and dispensing device 620 attached thereto, in the sealing station. In said sealing station, closure clip C at first end 612 of tubular casing 610 is gripped by gripping means, which

may similarly constructed like gripper 330 and removed from plait-like portion P by respective removing means, like one or more cutting elements. Subsequently, a seal 630 is attached to dispensing opening 628 of dispensing device 620. Said sealing operation may be a heat sealing. Alternatively, sealing device 630 may
5 also be mounted to dispensing device by a respective adhesive, like a hot-melt adhesive.

After the sealing operation, table 10 further turns counter-clockwise for positioning cartridge 20 with tubular casing 610 and dispensing device 620 in attachment station 400 vertically below the attachment means for attaching a closure cap 640
10 and/or a dispensing nozzle 650 to dispensing device 620. The attachment means include gripping and rotating means for gripping and screwing a closure cap 640 to dispensing device 620. Said attachment means are commonly known and thus, need not to be described in detail.

At discharge station 500, to which cartridge 20 together with the packing combination 600 is moved by further rotating table 10, packing combination 600 is re-
15 moved from cartridge 20 by lifter arrangement 512 and deposited on conveyor arrangement 514 for being distributed from assembling apparatus 1.

In conjunction with Fig. 2, drive assembly D has been described for moving upwardly cartridge 20 for positioning first end 32 of tubular casing 30 in the working
20 area of shaping station 200. Naturally, also the shaping 210 may be vertically movable, whereby an additional movement of cartridge 20, and drive assembly D respectively, is not necessary. It has also to be understood, that, even if not described, each working station may comprise a drive assembly D for moving cartridge 20 vertically into the working area of the respective work station.

Shaping ring 220 according to Fig. 2 consists of two segments 220a, 220b and has been described as being moved towards plait-like portion P after first end 32 has been grasped by claws 230. In an alternative embodiment, the shaping ring 220 may be formed as a single part. Accordingly, said shaping ring 220 has to be
25 placed around plait-like portion P before the first end 32 of tubular casing 30 has been grasped by claws 230.
30

Moreover, attachment station 400 needs not necessarily be part of the assembling apparatus, in particular, in case that no closure cap has to be attached to the packaging combination.

As it can be seen in Fig. 1, at table 10, additional space has been left for positioning additional work stations there, e.g. for attaching other parts to the packaging combination, like labels or the like.

Circular table 10 shown in Fig. 1, for moving tubular casing 30 between the work stations has to be understood as one possible embodiment of a moving device. Other moving means may be used for transporting the tubular casing between the work stations, like robotic devices or any other suitable conveying means.

The present assembling apparatus includes receiving means in the form of a band conveyor as one possible embodiment of a conveyor device. For receiving a tubular casing being at least partially filled and comprising a plait-like portion, the assembling apparatus may be directly connected to a clipping machine by said conveying means. Otherwise, a respective storage device including a number of tubular casings, may be coupled to said conveying means.

Claims

1. An apparatus for assembling a packaging combination including a tubular casing (610) having a first end (612) and a second end (614),
5 wherein the tubular casing (610) is partially filled with filling material and closed at its first as well as its second end (612, 614) by a closure means (C), like a closure clip, and wherein the partially filled tubular casing (610) comprises a plait-like portion (P) at its first end (612) being at least approximately free of filling material, and further including a dispensing device (620) having a passageway extending through the dispensing device (620) with an inlet opening at its one end and a dispensing opening at its other end for guiding and dispensing the filling material in a dispensing direction,
10 wherein the apparatus (1) comprises:
at least one supporting means (10, 20) for accommodating and retaining the at least partially filled tubular casing (610), including at least one cartridge (20) for arranging the at least partially filled tubular casing (610);
at least one shaping means (210) for creating a defined shape to the first end (612) of the tubular casing (610), including at least one gripper means (230) for gripping the first end of the at least partially filled tubular casing (610) and at least one forming shoulder (220) for forming a defined shape to the said first end (612); and
20 at least one mounting means (310) for mounting the dispensing device (620) to said first end (612) of the tubular casing (610).
25
2. The apparatus according to claim 1,
wherein the cartridge (20) is coupled with a drive means (D) for moving said cartridge (20).
3. The apparatus according to claim 2,
30 wherein the drive means (D) include a piston/cylinder assembly.

4. The apparatus according to any of claims 1 to 3,
wherein the forming shoulder (220) of the shaping means (210) is a
shaping ring having an inner surface corresponding to the shape to be
created of the first end (612) of the tubular casing (610).
- 5 5. The apparatus according to claim 4,
wherein the shaping ring (220) consists of ring segments (220a, 220b).
6. The apparatus according to any of claims 1 to 5,
wherein the gripper means (230) of the shaping means (210) include at
least one claw for gripping the first end (612) of the tubular casing
10 (610).
7. The apparatus according to any of claims 1 to 6,
wherein the shaping means (220) and/or the gripper means (230) in-
clude a drive means for reversible moving the shaping means (220) and
the gripper means (230) relative to each other.
- 15 8. The apparatus according to any of claims 1 to 7,
further comprising receiving means (110) for receiving the partially filled
tubular casing (610).
9. The apparatus according to any of claims 1 or 8,
further comprising receiving means (320) for receiving the dispensing
20 device (620).
10. The apparatus according to any of claims 1 to 9,
further comprising attachment means for attaching a closure cap (640)
and/or a dispensing nozzle (650) to the dispensing device (620).
11. The apparatus according to any of claims 1 to 10,
25 wherein at least the supporting means (10, 20), the shaping means
(210) and the mounting means (310) are arranged in work stations
(200, 300).

12. A method for assembling a packaging combination including a tubular casing (610) having a first end (612) and a second end (614), wherein the tubular casing (610) is partially filled with filling material and closed at its first as well as its second end (612, 614) by a closure means (C),
5 like a closure clip, and wherein the partially filled tubular casing (30) comprises a plait-like portion (P) at its first end (612) being at least approximately free of filling material, and further including a dispensing device (620) having a passage way extending through the dispensing device (620) with an inlet opening at its one end and a dispensing opening at its other end for guiding and dispensing the filling material in a
10 dispensing direction, the method comprises the steps of:
- accommodating and retaining the at least partially filled tubular casing (610);
 - positioning a forming shoulder (220) at the first end (612) of the tubular casing (610);
15
 - gripping the first end (612) of the tubular casing (610);
 - forming a defined shape to the first end (612) of said tubular casing (610) by moving the tubular casing (610) and the forming shoulder (220) relative to each other; and
 - 20 - mounting a dispensing device (620) to said first end (620) of said tubular casing (610).
13. The method according to claim 12,
further comprising the step of receiving the at least partially filled tubular casing (610).
- 25 14. The method according to claims 12 or 13,
further comprising the step of moving the at least partially filled tubular casing (610) between working stations (200, 300) including at least the supporting means (10, 20), the shaping means (210) and the mounting means (310).
- 30 15. The method according to any of claims 12 to 14,
further comprising the step of attaching a closure cap and a dispensing nozzle to the dispensing device (620).

16. A packaging combination for accommodating and dispensing a viscous or granular filling material, the packaging combination (600) comprises a tubular casing (610) having a first end (612) and a second end (614), wherein the tubular casing (610) is partially filled with filling material and closed at its
5 second end (614) by a closure means (C), like a closure clip, wherein the first end (612) is at least approximately free of filling material, the packaging combination (1) further comprises a dispensing device (620) having a passageway extending through the dispensing device (620) with an inlet opening (624) at its one end and a dispensing opening (628) at its other end for guid-
10 ing and dispensing the filling material in a dispensing direction (D), and being attached to the first end (612) of the partially filled tubular casing (610), wherein the first end (612) extends inside the passageway of the dispensing device (620), and wherein at least a sealing device (630) is removably attached to the dispensing device (620) for closing and sealing the dispensing
15 opening (628) of the dispensing device (620).

17. The packaging combination according to claim 16,
wherein the dispensing device (620) includes at least a first and a second portion (622, 626), wherein the first portion (622) extends from the inlet opening (624) of the passageway in the dispensing direction (D) and the second
20 portion (626) extends from the dispensing opening (628) opposite to the dispensing direction (D), and wherein the inner circumferential dimensions of the first portion (622) corresponds at least approximately to the outer circumferential dimensions of the tubular casing (610).

18. The packaging combination according to claims 16 or 17,
25 wherein it is provided a closure cap (640) reversibly attachable to the dispensing device (620).

19. The packaging combination according to any of claims 16 to 18,
wherein an indicating unit for indicating the originality of the closure of the dispensing opening (628) provided at the dispensing device (620).

20. The packaging combination according to claim 19,
wherein the indicating unit is attached to the closure cap (640).
21. The packaging combination according to any of claims 16 to 20,
wherein the dispensing device (620) is secured to the first end (612) of the
5 tubular casing (610) by an adhesive (630), in particular, by a hot-melt adhesive.
22. A dispensing device for being attached to a tubular casing (610) to form a
packaging combination (600) according to any of claims 16 to 21.
23. A tubular casing partially filled with a filling material and closed at its second
10 end (614) by a closure means (C), like a closure clip, for being combined with
a dispensing device (620) to form a packaging combination (600) according
to any of claims 16 to 21.

Fig. 1

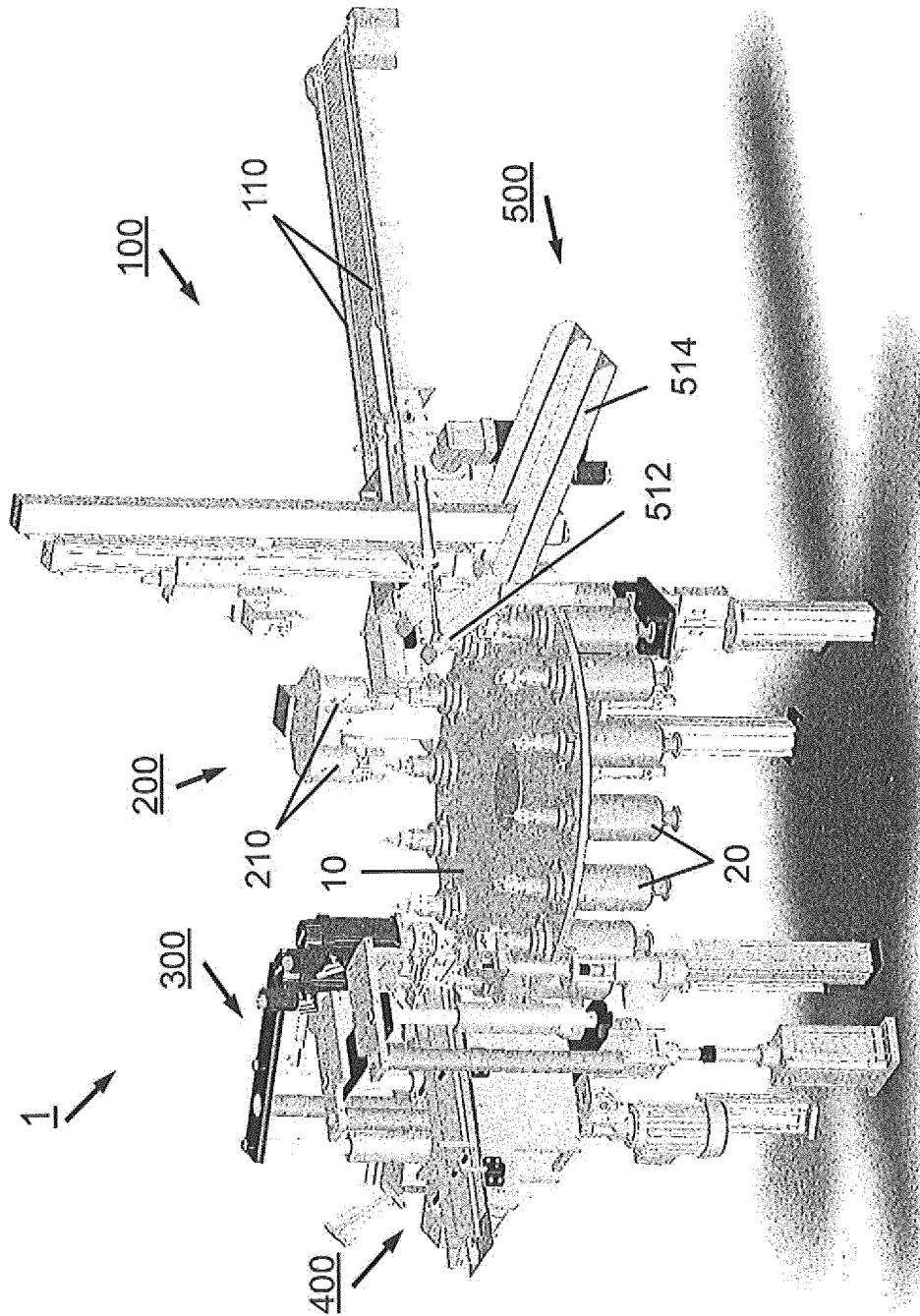

Fig. 2

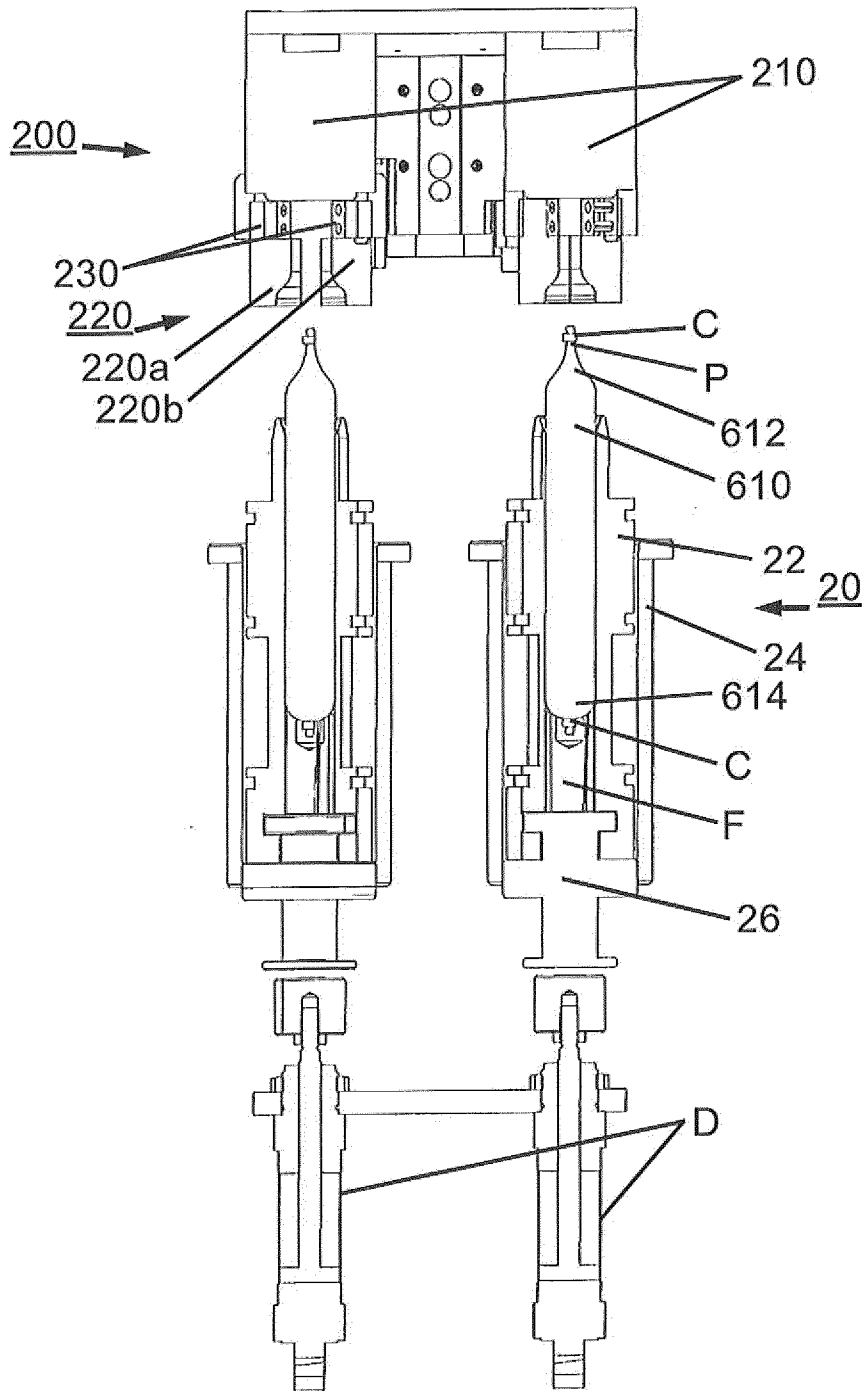
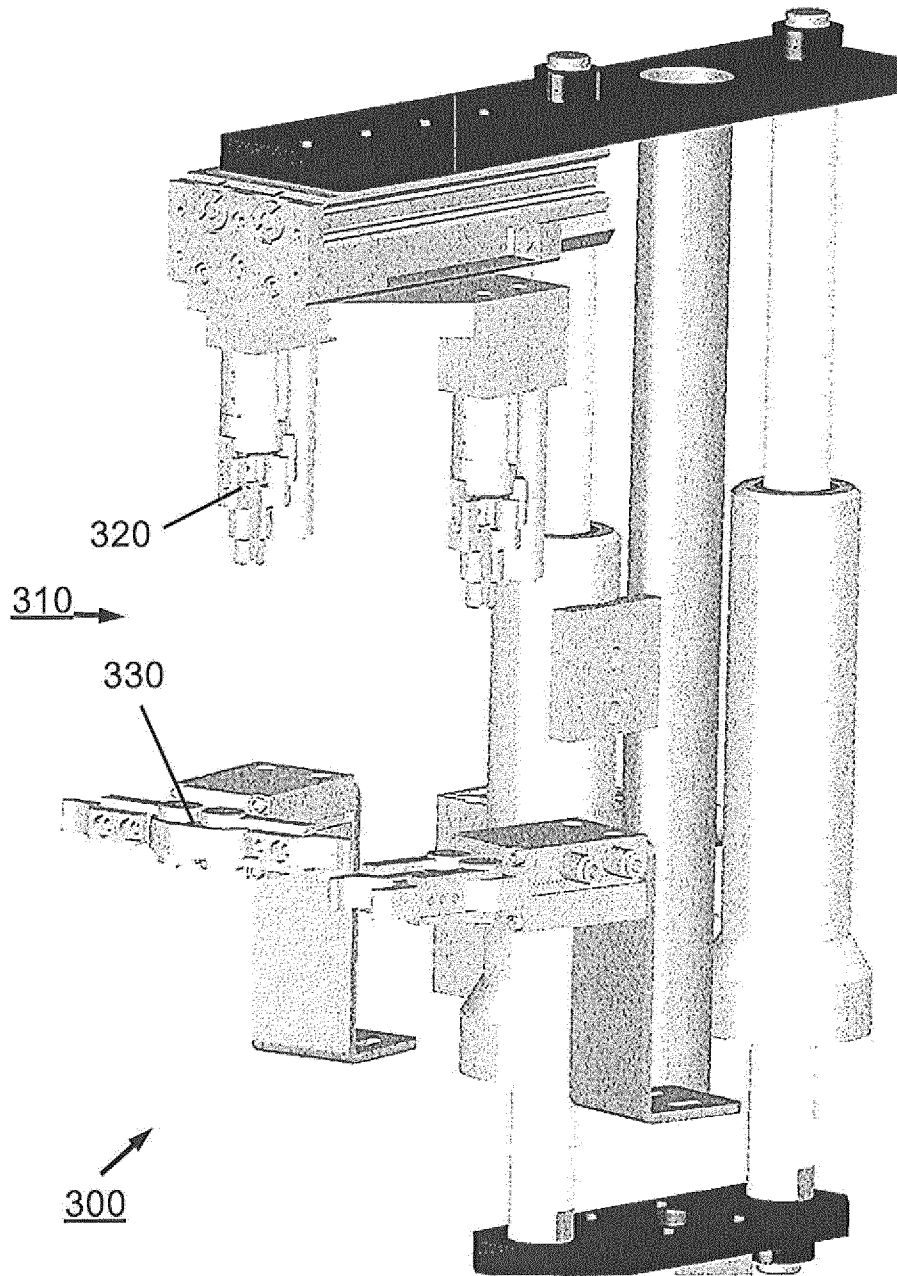

Fig. 3



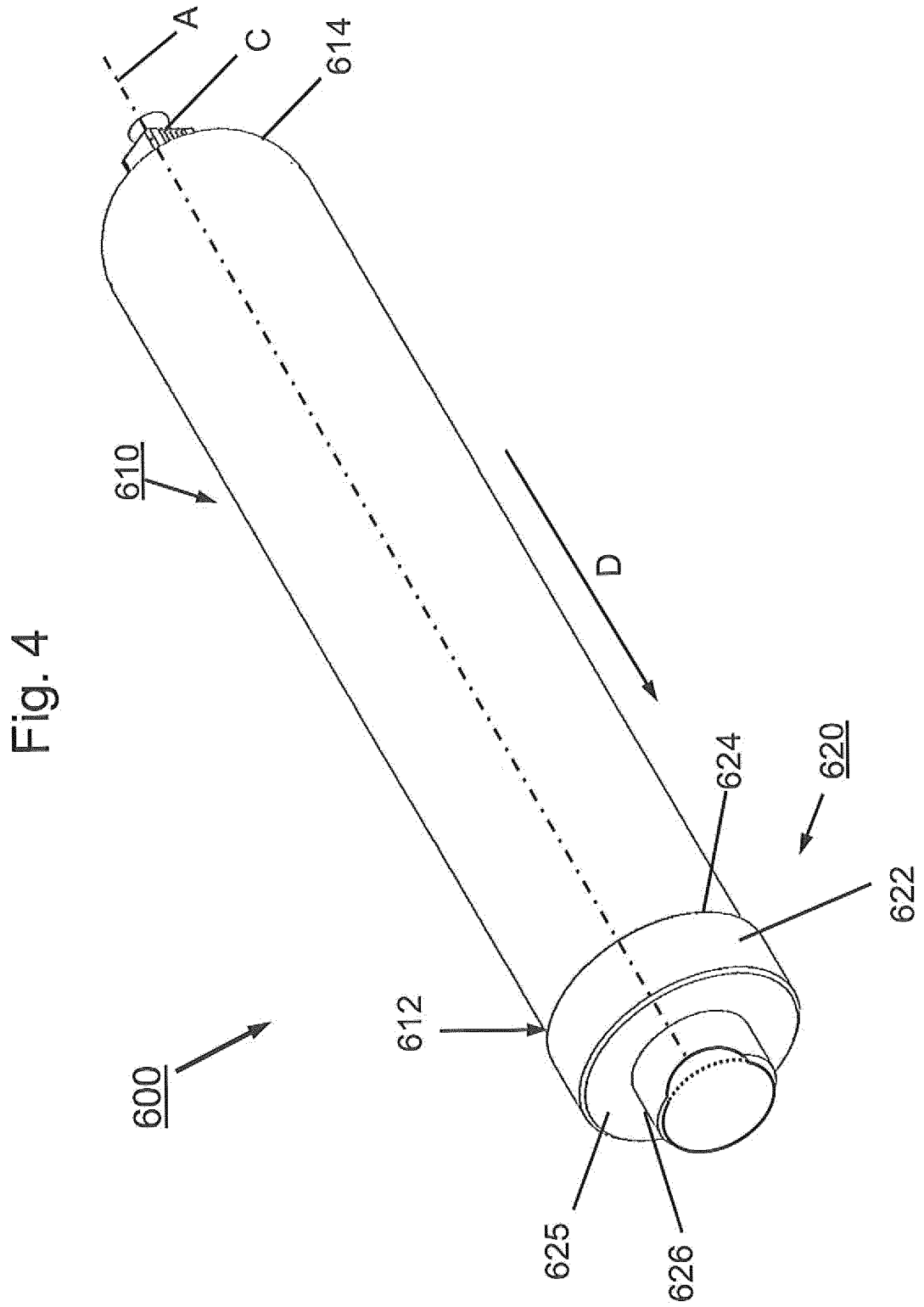

Fig. 5

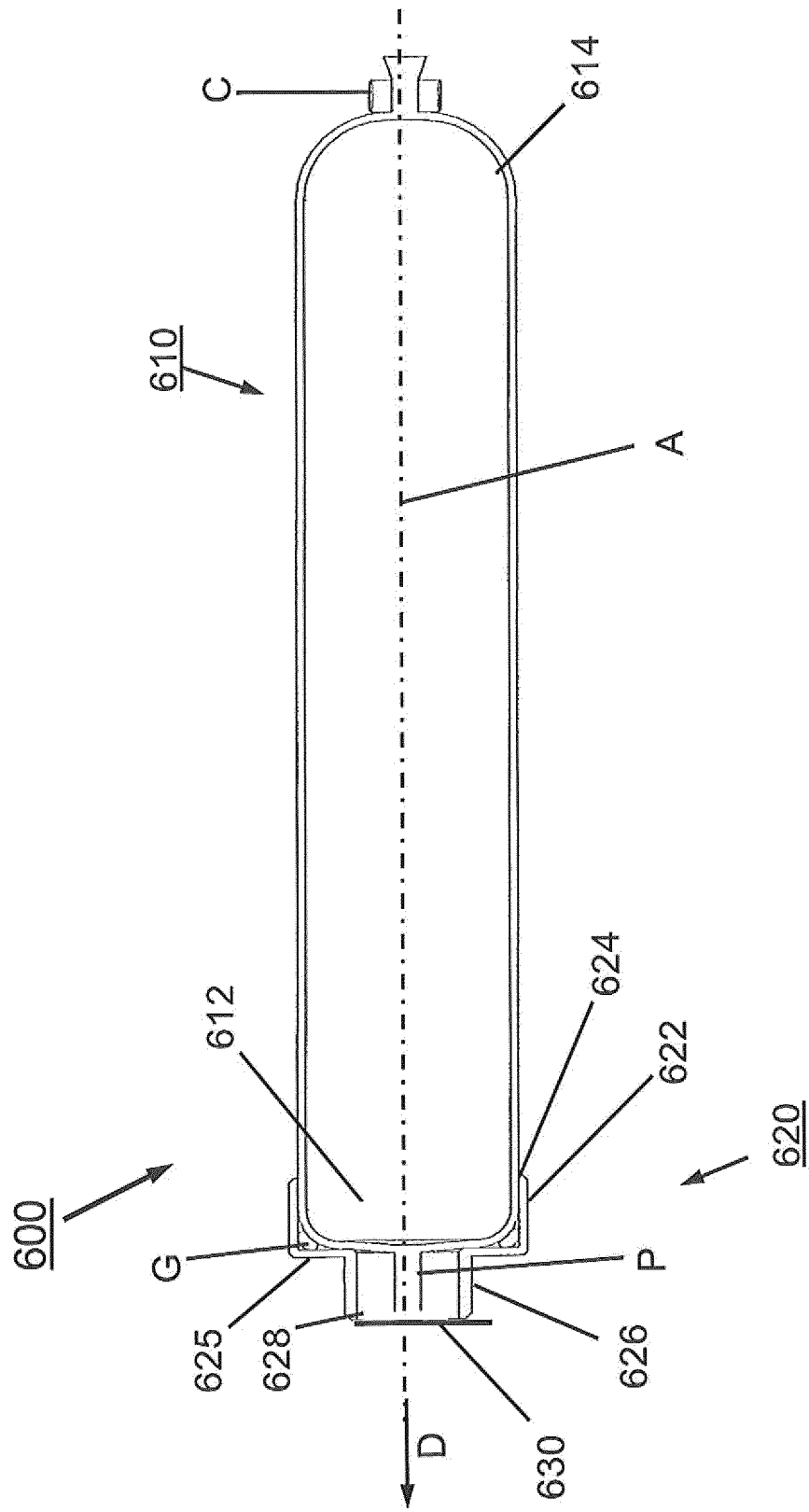

Fig. 6

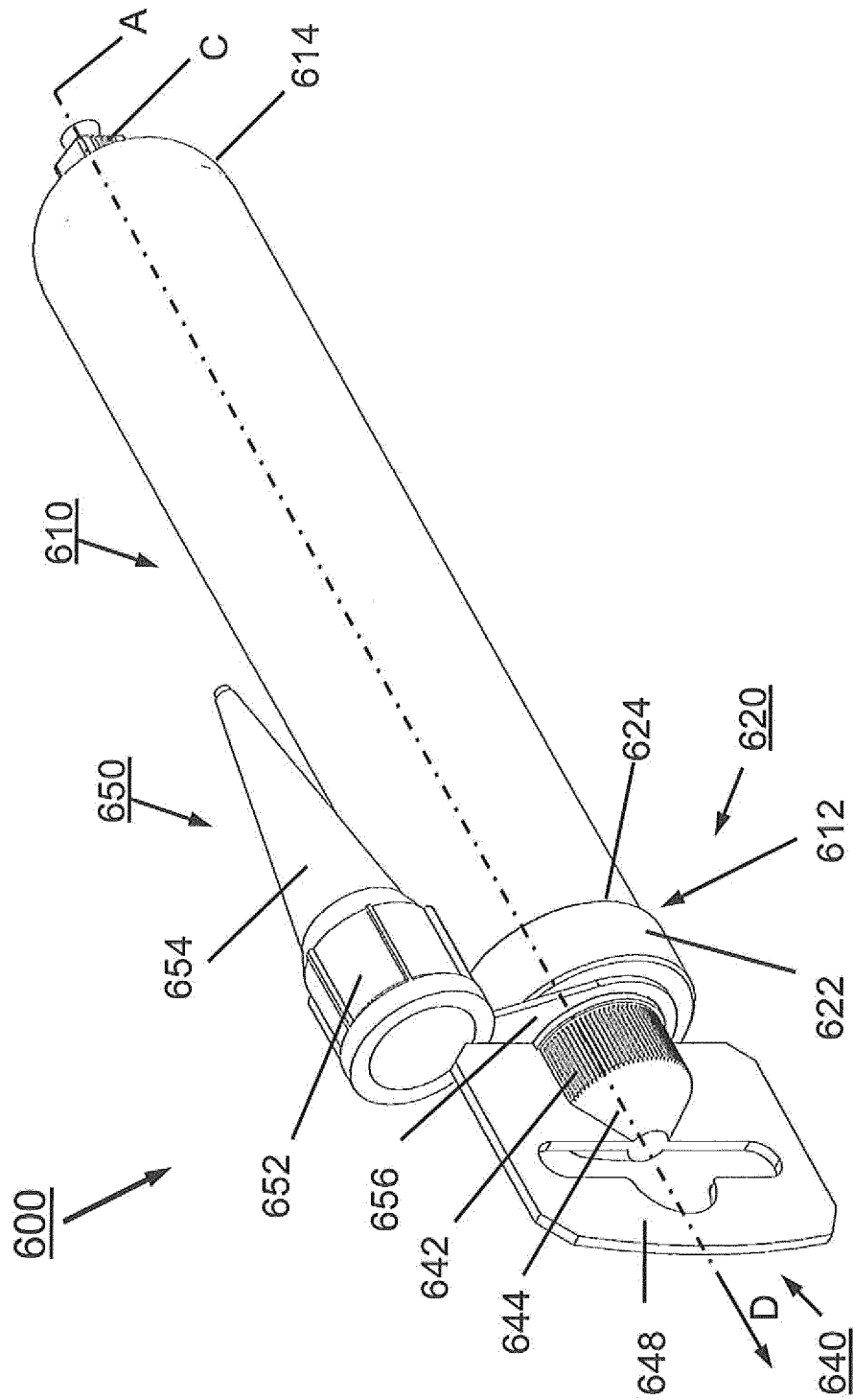
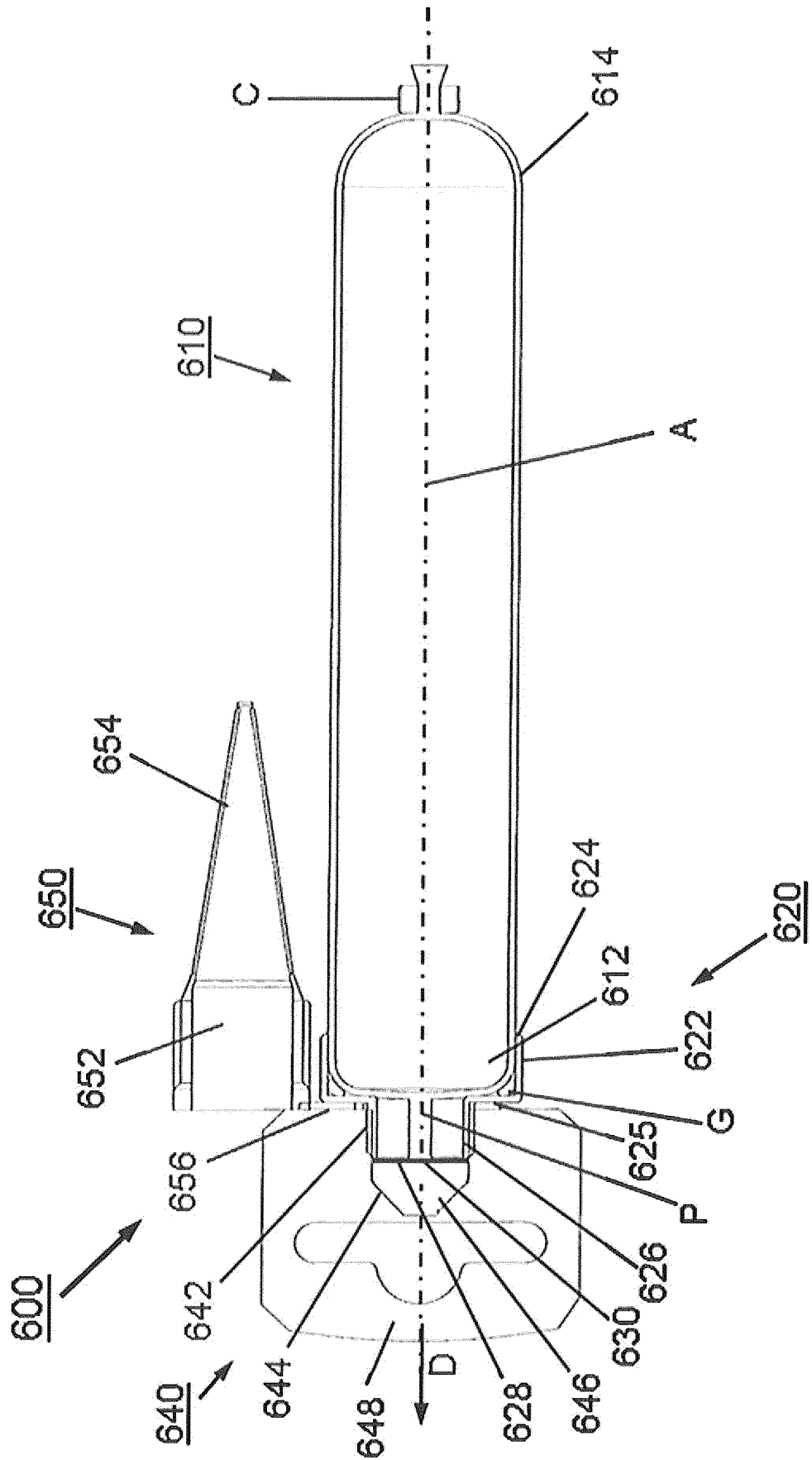

Fig. 7



INTERNATIONAL SEARCH REPORT

International application No
PCT/EP2012/058794

A. CLASSIFICATION OF SUBJECT MATTER
INV. B65B61/18 B05C17/005 B65D83/00
ADD.
According to International Patent Classification (IPC) or to both national classification and IPC

B. FIELDS SEARCHED
Minimum documentation searched (classification system followed by classification symbols)
B05C B05B B65D B65B

Documentation searched other than minimum documentation to the extent that such documents are included in the fields searched

Electronic data base consulted during the international search (name of data base and, where practicable, search terms used)
EPO-Internal

C. DOCUMENTS CONSIDERED TO BE RELEVANT

Category*	Citation of document, with indication, where appropriate, of the relevant passages	Relevant to claim No.
X	WO 86/04041 A1 (KNIERIEM GUENTHER [DE]) 17 July 1986 (1986-07-17) the whole document	12,13
Y		15
A		1-11,14
Y	----- US 2009/236365 A1 (SUMMONS WAYNE L [US] ET AL) 24 September 2009 (2009-09-24)	15
A	abstract; figures 1-12	16,18
Y	----- US 2005/198927 A1 (SUMMONS ELLIOT [US] ET AL) 15 September 2005 (2005-09-15)	15
	figure 2	
X	----- US 2003/197022 A1 (KELLER WILHELM A [CH]) 23 October 2003 (2003-10-23) paragraphs [0022] - [0023], [0028]; figures 2,7	16-19, 22,23
	----- -/--	

Further documents are listed in the continuation of Box C.

See patent family annex.

* Special categories of cited documents :

- "A" document defining the general state of the art which is not considered to be of particular relevance
- "E" earlier application or patent but published on or after the international filing date
- "L" document which may throw doubts on priority claim(s) or which is cited to establish the publication date of another citation or other special reason (as specified)
- "O" document referring to an oral disclosure, use, exhibition or other means
- "P" document published prior to the international filing date but later than the priority date claimed

"T" later document published after the international filing date or priority date and not in conflict with the application but cited to understand the principle or theory underlying the invention

"X" document of particular relevance; the claimed invention cannot be considered novel or cannot be considered to involve an inventive step when the document is taken alone

"Y" document of particular relevance; the claimed invention cannot be considered to involve an inventive step when the document is combined with one or more other such documents, such combination being obvious to a person skilled in the art

"&" document member of the same patent family

Date of the actual completion of the international search 23 October 2012	Date of mailing of the international search report 30/10/2012
--	--

Name and mailing address of the ISA/ European Patent Office, P.B. 5818 Patentlaan 2 NL - 2280 HV Rijswijk Tel. (+31-70) 340-2040, Fax: (+31-70) 340-3016	Authorized officer Garlati, Timea
--	--------------------------------------

INTERNATIONAL SEARCH REPORT

International application No
PCT/EP2012/058794

C(Continuation). DOCUMENTS CONSIDERED TO BE RELEVANT		
Category*	Citation of document, with indication, where appropriate, of the relevant passages	Relevant to claim No.
X	DE 199 64 027 A1 (FOLA ABFUELLTECHNIK GMBH [DE]) 12 July 2001 (2001-07-12) column 3, line 21 - column 4, line 24; figures 1-4 -----	16-23
X	DE 296 15 877 U1 (GURIT ESSEX AG [CH]) 7 November 1996 (1996-11-07)	22,23
A	page 5, lines 29-32 page 7, lines 3-7; figures 1-10 -----	16
X	JP 10 101155 A (NIHON TOKKYO KANRI CO LTD) 21 April 1998 (1998-04-21)	22,23
A	abstract; figures 1,6 -----	1,12
A	WO 2007/091071 A1 (RAWLPLUG LTD [GB]; CADDEN STEPHEN [GB]) 16 August 2007 (2007-08-16) abstract; figures 1-13 -----	1,12
A	EP 1 854 737 A2 (BOSSONG SPA [IT]) 14 November 2007 (2007-11-14) abstract; figures 1-6 -----	1,12
A	WO 2007/128996 A1 (RAWLPLUG LTD [GB]; CADDEN STEPHEN [GB]) 15 November 2007 (2007-11-15) abstract; figures 1-14 -----	1,12
A	EP 2 157 026 A1 (MUNGO BEFESTIGUNGSTECH AG [CH]) 24 February 2010 (2010-02-24) the whole document -----	1,12

INTERNATIONAL SEARCH REPORT

Information on patent family members

International application No

PCT/EP2012/058794

Patent document cited in search report	Publication date	Patent family member(s)	Publication date	
WO 8604041	A1	17-07-1986	AU 4805485 A NO 863573 A SE 8603365 A WO 8604041 A1	29-07-1986 08-09-1986 08-08-1986 17-07-1986
US 2009236365	A1	24-09-2009	AU 2009228386 A1 CA 2719084 A1 CN 102083548 A EP 2288448 A2 JP 2011515287 A US 2009236365 A1 WO 2009120705 A2	01-10-2009 01-10-2009 01-06-2011 02-03-2011 19-05-2011 24-09-2009 01-10-2009
US 2005198927	A1	15-09-2005	NONE	
US 2003197022	A1	23-10-2003	AU 6336399 A DE 69909115 D1 DE 69909115 T2 DE 69933399 T2 EP 0992438 A1 EP 1121308 A1 EP 1350736 A1 ES 2203187 T3 ES 2271412 T3 JP 4246920 B2 JP 2002527310 A US 6578738 B1 US 2003197022 A1 WO 0021858 A1	01-05-2000 31-07-2003 24-12-2003 19-07-2007 12-04-2000 08-08-2001 08-10-2003 01-04-2004 16-04-2007 02-04-2009 27-08-2002 17-06-2003 23-10-2003 20-04-2000
DE 19964027	A1	12-07-2001	NONE	
DE 29615877	U1	07-11-1996	DE 29615877 U1 ES 1035693 U FR 2741551 A3 IT MI960687 U1	07-11-1996 16-05-1997 30-05-1997 14-04-1998
JP 10101155	A	21-04-1998	NONE	
WO 2007091071	A1	16-08-2007	AU 2007213507 A1 CA 2640434 A1 CN 101378977 A EA 200870238 A1 EG 24941 A EP 1981781 A1 HK 1125346 A1 ME P5508 A NZ 570928 A RS 20080329 A US 2009179045 A1 WO 2007091071 A1 ZA 200807238 A	16-08-2007 16-08-2007 04-03-2009 27-02-2009 19-01-2011 22-10-2008 12-08-2011 10-02-2010 25-02-2011 31-12-2009 16-07-2009 16-08-2007 30-09-2009
EP 1854737	A2	14-11-2007	AT 476378 T EP 1854737 A2	15-08-2010 14-11-2007
WO 2007128996	A1	15-11-2007	AU 2007246930 A1 CA 2649185 A1	15-11-2007 15-11-2007

INTERNATIONAL SEARCH REPORT

Information on patent family members

International application No

PCT/EP2012/058794

Patent document cited in search report	Publication date	Patent family member(s)	Publication date	
		CN 101500905 A	05-08-2009	
		EA 200870422 A1	28-04-2009	
		EG 25085 A	01-08-2011	
		EP 2013109 A1	14-01-2009	
		ME P35508 A	10-02-2011	
		NZ 572322 A	30-09-2011	
		RS 20080474 A	31-12-2009	
		US 2009272761 A1	05-11-2009	
		WO 2007128996 A1	15-11-2007	
		ZA 200809330 A	29-07-2009	

EP 2157026	A1	24-02-2010	CH 699388 A1	26-02-2010
			EP 2157026 A1	24-02-2010

INTERNATIONAL SEARCH REPORT

International application No.
PCT/EP2012/058794

Box No. II Observations where certain claims were found unsearchable (Continuation of item 2 of first sheet)

This international search report has not been established in respect of certain claims under Article 17(2)(a) for the following reasons:

1. Claims Nos.:
because they relate to subject matter not required to be searched by this Authority, namely:

2. Claims Nos.:
because they relate to parts of the international application that do not comply with the prescribed requirements to such an extent that no meaningful international search can be carried out, specifically:

3. Claims Nos.:
because they are dependent claims and are not drafted in accordance with the second and third sentences of Rule 6.4(a).

Box No. III Observations where unity of invention is lacking (Continuation of item 3 of first sheet)

This International Searching Authority found multiple inventions in this international application, as follows:

see additional sheet

1. As all required additional search fees were timely paid by the applicant, this international search report covers all searchable claims.

2. As all searchable claims could be searched without effort justifying an additional fees, this Authority did not invite payment of additional fees.

3. As only some of the required additional search fees were timely paid by the applicant, this international search report covers only those claims for which fees were paid, specifically claims Nos.:

4. No required additional search fees were timely paid by the applicant. Consequently, this international search report is restricted to the invention first mentioned in the claims; it is covered by claims Nos.:

Remark on Protest

- The additional search fees were accompanied by the applicant's protest and, where applicable, the payment of a protest fee.
- The additional search fees were accompanied by the applicant's protest but the applicable protest fee was not paid within the time limit specified in the invitation.
- No protest accompanied the payment of additional search fees.

FURTHER INFORMATION CONTINUED FROM PCT/ISA/ 210

This International Searching Authority found multiple (groups of) inventions in this international application, as follows:

1. claims: 1-15

An apparatus and a method for assembling a packaging combination.

2. claims: 16-21

A packaging combination

3. claim: 22

A dispensing device

4. claim: 23

A tubular casing
