

(19) World Intellectual Property Organization
International Bureau



(43) International Publication Date
4 May 2006 (04.05.2006)

PCT

(10) International Publication Number
WO 2006/046721 A1

- (51) International Patent Classification : **B65D 51/28**
- (21) International Application Number:
PCT/JP2005/019939
- (22) International Filing Date: 25 October 2005 (25.10.2005)
- (25) Filing Language: English
- (26) Publication Language: English
- (30) Priority Data:
2004-309581 25 October 2004 (25.10.2004) JP
- (71) Applicant (for all designated States except US): **THE COCA-COLA COMPANY** [US/US]; One Coca-Cola Plaza, N.W., Atlanta, Georgia 30313 (US).
- (72) Inventors; and
- (75) Inventors/Applicants (for US only): **IWASHITA, Hiromasa** [JP/JP]; 6-3, Shibuya 4-chome, Shibuya-ku, Tokyo 1500002 (JP). **HASHIMOTO, Kazunori** [JP/JP]; c/o YOSHINO KOGYOSHO CO., LTD., 2-6, Ojima 3-chomeKoto-ku, Tokyo 1368531 (JP). **NOSE, Kazuaki** [JP/JP]; c/o YOSHINO KOGYOSHO CO., LTD., 2-6, Ojima 3-chomeKoto-ku, Tokyo 1368531 (JP).

- (74) Agents: **SUGIMURA, Kosaku** et al.; 7F, Kazan Building, 2-4, Kasumigaseki 3-chome, Chiyoda-ku, Tokyo 1000013 (JP).
- (81) Designated States (unless otherwise indicated, for every kind of national protection available): AE, AG, AL, AM, AT, AU, AZ, BA, BB, BG, BR, BW, BY, BZ, CA, CH, CN, CO, CR, CU, CZ, DE, DK, DM, DZ, EC, EE, EG, ES, FI, GB, GD, GE, GH, GM, HR, HU, ID, IL, IN, IS, JP, KE, KG, KM, KP, KR, KZ, LC, LK, LR, LS, LT, LU, LV, LY, MA, MD, MG, MK, MN, MW, MX, MZ, NA, NG, NI, NO, NZ, OM, PG, PH, PL, PT, RO, RU, SC, SD, SE, SG, SK, SL, SM, SY, TJ, TM, TN, TR, TT, TZ, UA, UG, US, UZ, VC, VN, YU, ZA, ZM, ZW.
- (84) Designated States (unless otherwise indicated, for every kind of regional protection available): ARIPO (BW, GH, GM, KE, LS, MW, MZ, NA, SD, SL, SZ, TZ, UG, ZM, ZW), Eurasian (AM, AZ, BY, KG, KZ, MD, RU, TJ, TM), European (AT, BE, BG, CH, CY, CZ, DE, DK, EE, ES, FI, FR, GB, GR, HU, IE, IS, IT, LT, LU, LV, MC, NL, PL, PT,

[Continued on next page]

(54) Title: BOTTLE CAP WITH A STORAGE CHAMBER

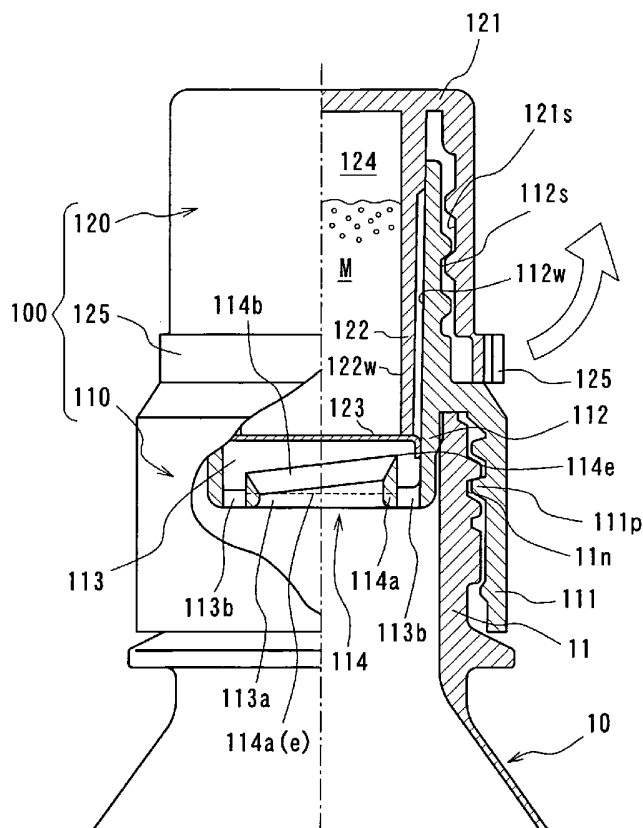

(57) Abstract: A cap with a storage chamber for storing an ingredient to be added to a liquid content within a container (10) includes a base (110) to be attached to a mouth portion of the container, which has a spout (113) for allowing passage of the liquid content out of the container (10). A lid (120) is fastened by screwing to the base (110) and includes the storage chamber (124) and a thin sheet (123) for sealing it. The base (110) has an annular part (114a) fixed to an inner wall of the spout, for maintaining a channel communicating with an interior space of the container (10). The base (110) has a slanted blade (114b) which comes into contact with the thin sheet (123) as the lid (120) is moved downwards, for cutting the thin sheet and allowing the ingredient in the storage chamber (124) to fall into the interior space of the container (10) and mixed with the content therein.

WO 2006/046721 A1



RO, SE, SI, SK, TR), OAPI (BF, BJ, CF, CG, CI, CM, GA, GN, GQ, GW, ML, MR, NE, SN, TD, TG).

For two-letter codes and other abbreviations, refer to the "Guidance Notes on Codes and Abbreviations" appearing at the beginning of each regular issue of the PCT Gazette.

Published:

— *with international search report*

BOTTLE CAP WITH A STORAGE CHAMBERTECHNICAL FIELD

[0001] The present invention relates to a bottle cap with a chamber for
5 storing an ingredient to be added to a content within a bottle.

BACKGROUND ART

[0002] There is known a bottle cap including a base which can be attached to
the mouth portion of a container, and which has a spout for allowing the passage
of the content in the bottle, a lid capable of moving upwards or downwards
10 relative to the base, wherein the lid defines a storage chamber for the ingredient,
which is sealed with a thin sheet, and a seal opener within the base. The seal
opener approaches the thin sheet as the lid is pressed and thereby moved
downwards, for breaking and opening the sheet, so that the ingredient stored in
the storage chamber is allowed to fall through the opening into the interior of the
15 bottle and added to the liquid content therein. In this instance, if a force beyond
a certain limit is accidentally applied to the lid, the seal opener would be brought
into contact with the thin sheet to break it inadvertently. Therefore, in order to
avoid such a problem, Japanese Unexamined Utility Model Application
Publication No. JP 05-770549U proposes a bottle cap in which the lid is fastened
20 to the base by screwing so that the lid can be moved upwards or downwards
relative to the base by screwing operation, and in which the seal opener is in the
form of a plate-like flat blade.

[0003] However, in the bottle cap according to the above-mentioned proposal,
the flat blade is moved in a tangential direction with respect to a circle
25 circumscribed by the rotation of the lid, so that it may happen that the blade
drags the thin sheet when trapped by the thin sheet. In this instance, it is
necessary to screw in the lid with a considerable force, thereby giving rise to
inconvenience for children and aged people.

[0004] Another bottle cap with an ingredient-storage chamber has been
30 alternatively proposed and comprises seal opener in the form of a circular saw-
tooth blade which consists of a series of saw-teeth formed into a ring. This type
of the blade, however, is not free from the problem of the entrapment by the thin

sheet, either.

DISCLOSURE OF THE INVENTION

[0005] It is therefore an object of the present invention to overcome the inconvenience encountered with conventional bottle caps, and capable of
5 positively avoiding undesirable entrapment of the seal-opening blade by the thin sheet during the cutting operation.

[0006] According to the present invention, there is provided a cap with a storage chamber for storing an ingredient to be added to a liquid content within a container, wherein the cap includes a base to be attached to a mouth portion of
10 the container, which has a spout for allowing passage of the liquid content out of the container, and a lid fastened by screwing to the base such that it is moved upwards or downwards depending on a screwing direction. The lid includes the storage chamber and a thin sheet for sealing it. The base has an annular part fixed to an inner wall of the spout, so that the annular part maintains a channel
15 communicating with an interior space of the container. The base has, on its upper edge portion, a blade slanted relative to a horizontal plane, and extending along an upper edge of the annular part. The slanted blade comes into contact with the thin sheet as the lid is screwed and moved downwards, for cutting and opening the thin sheet and thereby allowing the ingredient in the storage chamber
20 to fall into the interior space of the container and mixed with the content therein.

[0007] According to the present invention, since the slanted blade with a tapered cutting edge is provided along the periphery of the annular part, and is moved downwards by a downward movement of the base due to screwing-in of the lid, a summit cutting edge of the slanted blade breaks and opens the thin sheet
25 progressively, to eliminate the risk of the blade being trapped by the thin sheet during its cutting operation. It is thus possible to smoothly cut the thin sheet without forcibly spinning the lid, thereby advantageously realizing a cap which is easy in operation and excellent in performance.

[0008] The slanted blade may be a circular blade provided along an entire
30 upper edge of the annular part, having a protruded cutting edge. Alternatively, the slanted blade may be an arcuate blade locally provided on an upper edge of the annular part.

[0009] It is preferred that a rib is provided at an area adjacent to the slanted blade so as to dislocate a cut end of the thin sheet from the opening while the thin sheet is cut by the blade.

[0010] It is also preferred that a stopper is arranged in a gap between the base and the lid, for restricting the downward movement of the lid, said stopper being
5 removable from the gap.

BRIEF DESCRIPTION OF THE DRAWINGS

[0011] The present invention will be more specifically described below with reference to the attached drawings.

10 [0012] FIG. 1 is a sectional view of a cap according to a first embodiment of the present invention.

[0013] FIG. 2 is a sectional view explaining the operation of the cap shown in FIG. 1.

[0014] FIGS. 3(a) and 3(b) are, respectively, a perspective view and a
15 diagram showing the structure and operation of the slanted cutting blade in the first embodiment of the present invention.

[0015] FIGS. 4(a) and 4(b) are, respectively, a perspective view and a plan view showing the structure and operation of the slanted cutting blade according to a second embodiment of the present invention.

20 [0016] FIGS. 5(a) and 5(b) are perspective views showing a modification of the first embodiment, incorporating a modified slanted blade and a variant of the rib provided adjacent to the slanted blade.

BEST MODE FOR CARRYING OUT THE INVENTION

[0017] In FIGS. 1 and 2, reference numeral 100 denotes a cap with a storage
25 chamber according to a first embodiment of the present invention. The cap 100 comprises a base 110 to be attached to the mouth 11 of a bottle-shaped container 10, which may comprise a suitable plastic material such as PET, and a lid 120 to be fastened to the base 110, e.g., by screwing. The lid 120 comprises a cylindrical portion 122 hanging from a cover 121 covering the base 110
30 downward with its lowest end being open, and a thin sheet 123 for sealing the open end of the cylindrical portion 122. Thus, the lid 120 defines a hermetically sealed storage chamber 124 in an interior space surrounded by the

cylindrical portion 122 and the thin sheet 123, for storing an ingredient M in the form of powder, particles or liquid.

[0018] The base 110 comprises an outer cylinder 111 having a female thread on its inner wall to mate with a male thread formed on the outside of the mouth portion 11 of the container, and an inner cylinder 112 continuous with the outer cylinder 111, which snugly fits to the inner surface of the mouth portion of the container. The inner cylinder 112 has a male thread 112s on its portion projecting from the mouth portion 11 of the container, which mates with a female thread 121s formed on the cover 121 of the lid 120 for fastening the lid 120 to the base 110 by screwing. When the lid 120 is fastened to the base 110, the inner cylinder 112 is brought into frictional contact at its inner wall 112w with the cylindrical body 122 so as to movably hold it by friction. The inner cylinder 112 further includes, at its center, a spout passage 113 for pouring out a liquid content out of the container 10.

[0019] In the spout passage 113, as shown in FIG. 3(a), there is provided an annular part 114a supported by a plurality of beams 115. On the upper edge 114a(e) of the annular part 114a, there is provided a slanted blade 114b, as shown in FIGS. 1 and 3(a). The blade 114b forms, in its vertical profile, a tapered edge with the wall vertically extending from the annular part 114a with a peak (cutting edge) 114e at the intersection. The slanted blade 114b is a circular blade formed along the entire upper edge portion 114a(e) of the annular part 114a. This means that the blade 114b appears, in its projected image, as if the annular part 114a has been cut obliquely at the upper edge portion 114a(e). As shown in FIG. 3(a), the annular part 114a further includes in its interior a channel 113a which communicates with the interior space of the bottle 10 and forms part of the spout passage 113, and additional channels 113b each the adjacent beams 115, which also form part of the spout passage 113.

[0020] Furthermore, in the first embodiment, the cover 121 of the lid 120 integrally comprises a removable stopper 125 as shown in FIG. 1, which restricts an excessive downward movement of the lid 120, which otherwise occurs when screwed in. The stopper 125 will be torn off by slightly displacing the lid 120 downwards, thereby releasing the lid 120 from the restriction, and allowing it to

be further screwed in or out freely.

[0021] The operation of the first embodiment is as follows.

[0022] First, a user tears off the stopper 125 from all around the lid 120 by a manual squeezing, as indicated by an arrow in FIG. 1. Then, a gap is formed
5 between the cover 121 of the lid 120 and the outer cylinder 111 of the base 110, and thus the user can rotate the lid clockwise or counterclockwise such that the lid 120 can be screwed in toward the base 110. The lid 120 is moved downwards as a result of being screwed in, and the cutting edge 114e of the slanted blade 114b breaks and opens the thin sheet 123 by moving upwards as
10 indicated by an arrow D1 in FIG. 3(b). With the further screwing-in of the lid 120, the slanted blade 114b progressively cuts the thin sheet 123 in a circumferential direction indicated by an arrow D2 in FIG. 3(b), tracing the circumference of a circle. As a result of such operation, the thin sheet 123 is cut as shown in FIG. 2, and the storage chamber 124 is opened. Thus, the
15 ingredient M stored in the chamber 124 is allowed to fall along the spout passage 113 and the channels 113a, 113b, into the interior space of the bottle 10, and is added to the liquid content therein. When it is required to pour a resulting solution out of the bottle 10, the lid 20 is rotated in a direction opposite to the previous one until the lid 120 is removed from the base 110, and then the solution
20 obtained by dissolving the ingredient M to the liquid content can be readily poured out.

[0023] According to the first embodiment explained above, since the slanted blade 114b with a tapered cutting edge is provided along the periphery of the annular part 114a, and is moved downwards by a downward movement of the
25 base 110 due to screwing-in of the lid 120, the summit cutting edge 114e of the slanted blade 114b breaks and opens the thin sheet 123 progressively, to eliminate the risk of the blade 114b being trapped by the thin sheet 123 during its cutting operation. It is thus possible to smoothly cut the thin sheet 123 without forcibly spinning the lid 120, thereby advantageously realizing a cap that is easy
30 in operation and excellent in performance.

[0024] Moreover, as shown in FIGS. 1 and 2, the slanted blade 114b in the first embodiment includes a tapered edge having, in its vertical profile, a slope

slanting towards the passage 113a communicating with the interior space of the container 10. Since the slanted blade 114b is configured as described above, the thin sheet 123 hardly stretches between the inner annular wall 122w of the lid 120 and the slanted blade 114b, even when the slanted blade 114b is brought into contact with the thin sheet 123, thereby allowing the thin sheet 123 to be easily cut and opened by the slanted blade 114b.

[0025] Still further, in the first embodiment, since stopper 125 is detachably attached to the cover 121 of the lid 120 to restrict the downward movement of the lid 120, it is possible to safely avoid the risk of breaking the thin sheet 123 by an accidental downward displacement of the lid 120. The stopper 125 may be formed in association with, or integrally with the molding of the base 110, as long as the stopper 125 can be detachably arranged between the base 110 and the lid 120. Alternatively, the stopper 125 may have a substantially C-shaped profile, and formed as an element that is independent from the base 110 and the lid 120. Then it is possible to detachably insert the stopper 125 into the gap between the base 110 and the lid 120.

[0026] FIG. 4(a) is a perspective view showing a cap according to a second embodiment of the present invention, which incorporates a variant of the slanted blade. In the second embodiment, the general structure of the cap is the same as that of the first embodiment shown in FIGS. 1 and 2. In the following description, the elements corresponding to those shown in FIGS. 1 to 3 are denoted by the same reference numerals and a superfluous explanation is omitted for the sake of simplicity.

[0027] In the cap according to the second embodiment of the present invention, a slanted blade 114c with a tapered end is provided locally along the upper edge portion 114a(e) of the annular part 114a that is fixed by the beams 115 to the inner wall of the spout passage 113. The slanted blade 114c is generally in the form of an arcuate blade formed along the upper end portion 114a(e) of the annular part 114a, except for a protruded cutting edge 114e. The arcuate blade 114c thus has a pointed cutting edge along the upper edge portion 114a(e) of the annular part 114a.

[0028] According to the second embodiment configured as described above,

when the lid 120 is rotated and thereby moved downwards, i.e., toward the base 110, the pointed cutting edge 114e of the arcuate blade 114c breaks and opens the thin sheet 123. When the lid 120 is further rotated and moved downwards, the thin sheet 123 is caused to rotate thereby allowing the arcuate blade 114c to progressively cut the thin sheet 123 with the rotation of the sheet 123. It is thus possible to eliminate the risk of the blade 114c being trapped by the thin sheet 123 during its cutting operation. It is also possible to smoothly cut the thin sheet 123 without forcibly spinning the lid 120, thereby advantageously realizing a cap that is easy in operation and excellent in performance.

10 **[0029]** Moreover, according to the second embodiment, as indicated by the hatched area of FIG. 4(a), there is provided a rib 116 at a region A of the arcuate blade 114c. The rib 116 is provided for expanding the opening when the arcuate blade 114c cuts the thin sheet 123, forcibly displacing the cut ends of the thin sheet 123. In this instance, as shown in FIG. 4(b), even when the thin sheet 123 is not completely cut by the arcuate blade 114c as a result of insufficient screwing-in of the lid 120, the face 116f of the rib 116 in the advancing direction displaces the cut end of the thin sheet 123 to expand the opening, thereby allowing the ingredient M stored in the chamber 124 to positively fall into the interior space of the container 10.

20 **[0030]** The rib 116 may be placed at any desired location relative to the annular part 114a, as long as it is implemented at an area A with respect to the arcuate blade 114c. However, the rib 116 is preferably placed with respect to the pointed cutting edge 114e such that it is situated directly below the cutting point 114e to be aligned with the latter, as shown in FIG. 4(a). In this instance, it is possible to even more efficiently displace the cut end of the thin sheet 123 so as to expand the opening C.

[0031] FIG. 5(a) shows a modification of the first embodiment shown in FIGS. 1 to 3, which is modified to incorporate the rib 116. The rib 116 may be placed at any desired location with respect to the annular part 114a, since the circular blade 114b is arranged along the entirety of the upper edge portion 114a(e) of the annular part 114a. However, as discussed above with reference to FIG. 4(a), the rib 116 is preferably placed at the hatched area A in FIG. 5(a),

particularly an area directly below the summit cutting point 114e. In this embodiment too, it is possible to efficiently displace the cut ends of the thin sheet 123 to expand the opening C.

5 [0032] The rib 116 has a face 116f that comes into direct contact with the cut end of the thin sheet 123. The edge of the face 116f is not limited to an angular shape as shown in FIGS. 4(a) and 5(a), but may be beveled as shown in FIG. 5(b). In this instance, the displacement of the cut end of thin sheet 123 formed by the slanted blade 114b, 114c is further enhanced, encountering less resistance from the thin sheet 123.

10 [0033] The present invention is not limited to the illustrated embodiments described above, and modifications and variations may be made without departing from the scope of the invention as defined by the appended claims. Thus, for example, while the base 110 in the above-mentioned embodiments is attached to the mouth portion of a container by mating a male thread 111p on the
15 inner face of the outer cylinder 111 of the base 110 with a female thread 11n on the mouth part 11 of the container, a reversed arrangement is also possible in which the mouth portion 11 of the container has a male thread and the inner wall of the outer cylinder 111 of the base 110 has a corresponding female thread. Suitable containers 10 to which the cap according to the present invention is
20 applicable are not limited to bottles, and may include containers having various shapes or comprising different materials.

CLAIMS

1. A cap with a storage chamber for storing an ingredient to be added to a liquid content within a container, comprising a base to be attached to a mouth portion of the container, said base including a spout for allowing passage of the liquid content out of the container, and a lid fastened by screwing to the base such that it is moved upwards or downwards depending on a screwing direction, wherein:

the lid includes said storage chamber and a thin sheet for sealing the storage chamber;

the base has an annular part fixed by beams to an inner wall of the spout, said annular part maintaining a channel communicating with an interior space of the container, and having, on its upper end portion, a blade slanted relative to a horizontal plane, and extending along an upper edge of the annular part so as to be brought into contact with the thin sheet as the lid is screwed and moved downwards, for cutting and opening the thin sheet, thereby allowing the ingredient in the storage chamber to fall into the interior space of the container and mixed with the liquid content therein.

2. The cap according to Claim 1, wherein said slanted blade is a circular blade provided along an entire upper edge of the annular part, having a protruded cutting edge.

3. The cap according to Claim 1, wherein said slanted blade is an arcuate blade locally provided on an upper edge of the annular part.

4. The cap according to any one of Claims 1 to 3, wherein a rib is provided at an area adjacent to the slanted blade so as to dislocate a cut end of the thin sheet from the opening while the thin sheet is cut by the blade.

5. The cap according to any one of Claims 1 to 4, further comprising a stopper arranged in a gap between the base and the lid, for restricting the downward movement of the lid, said stopper being removable from the gap.

FIG. 1

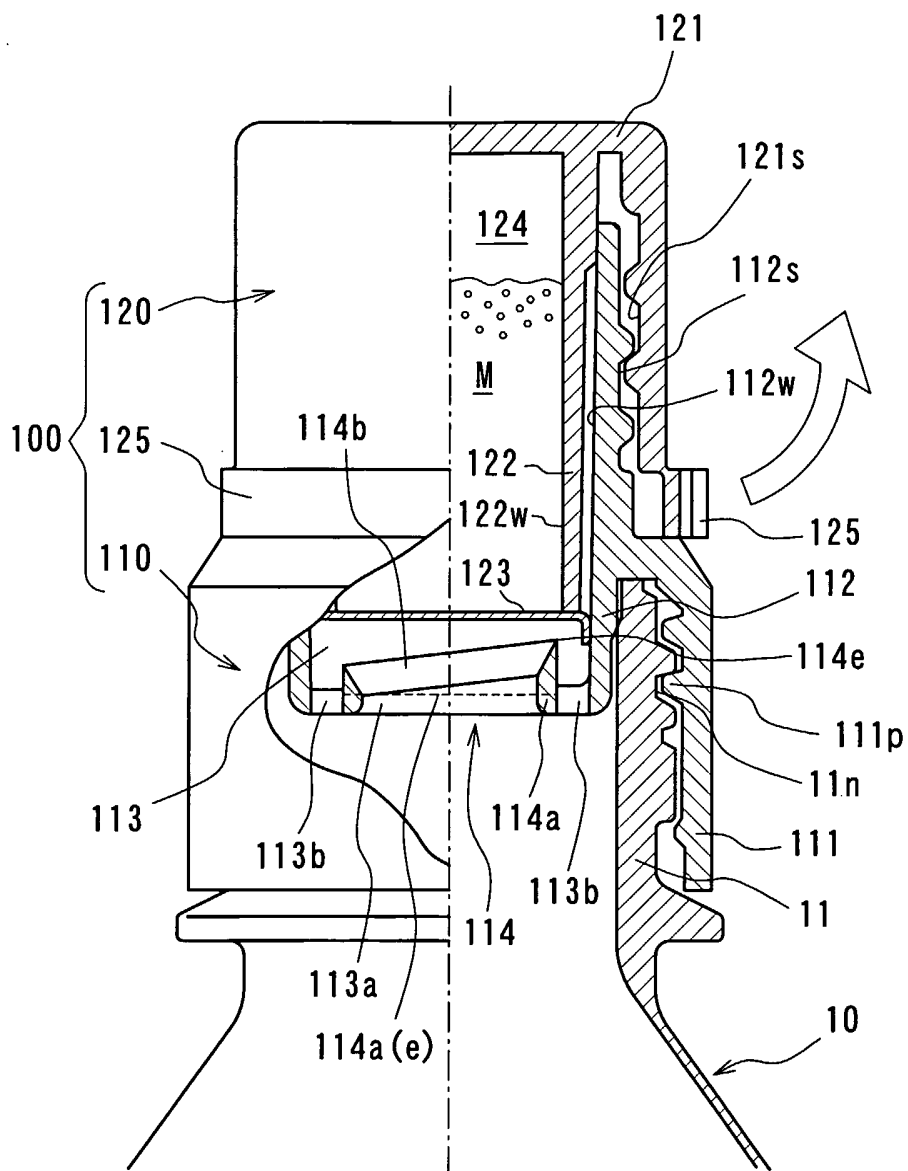

FIG. 2

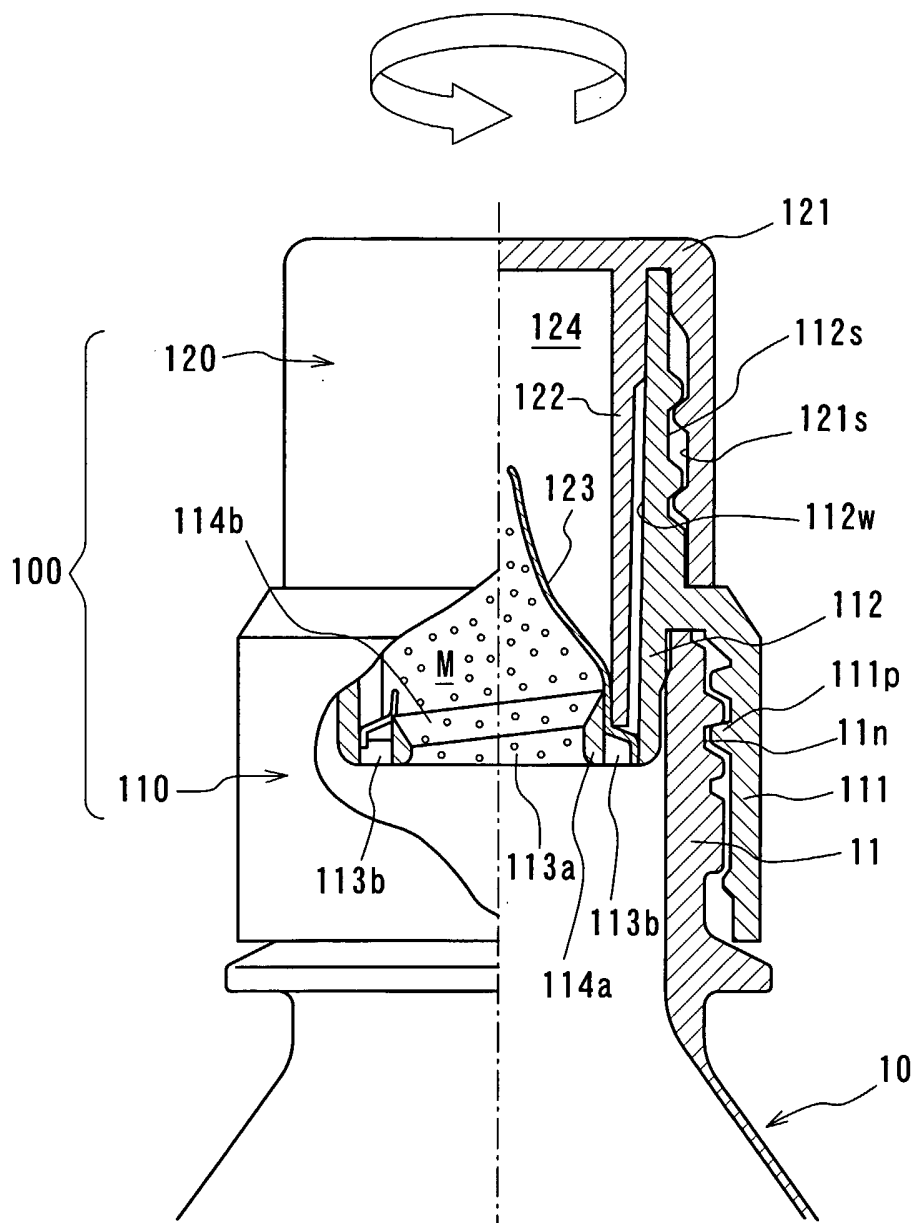

FIG. 3

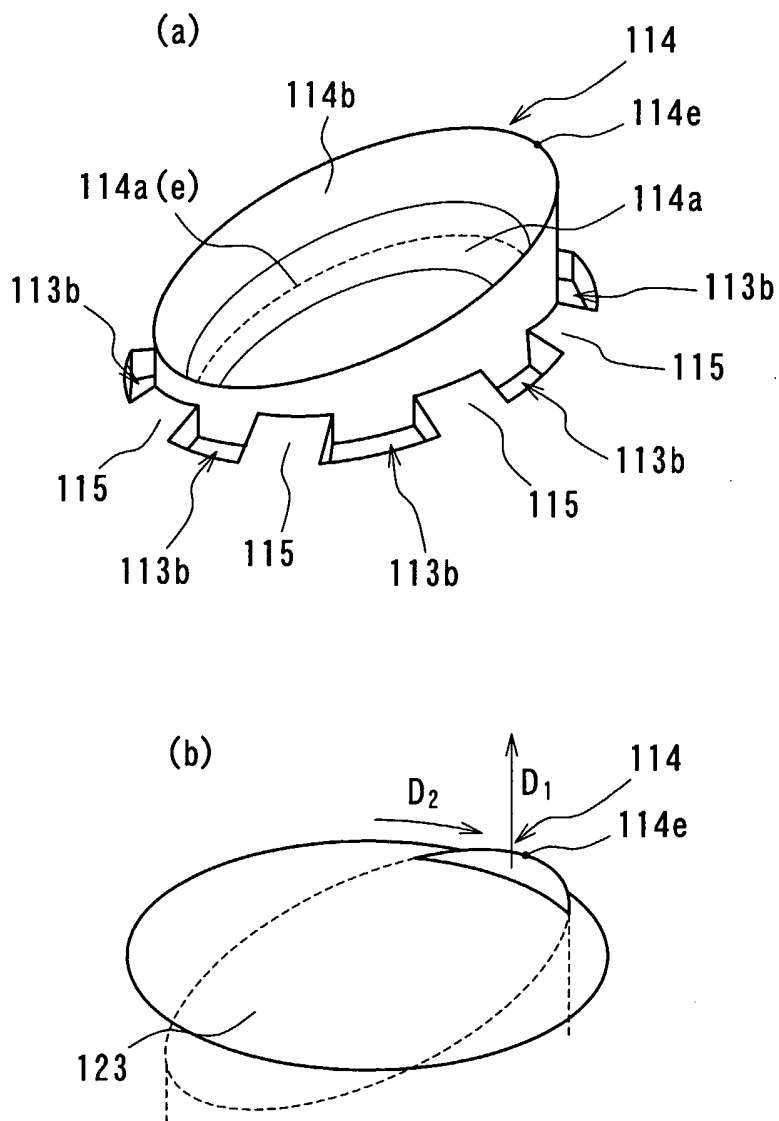

FIG. 4

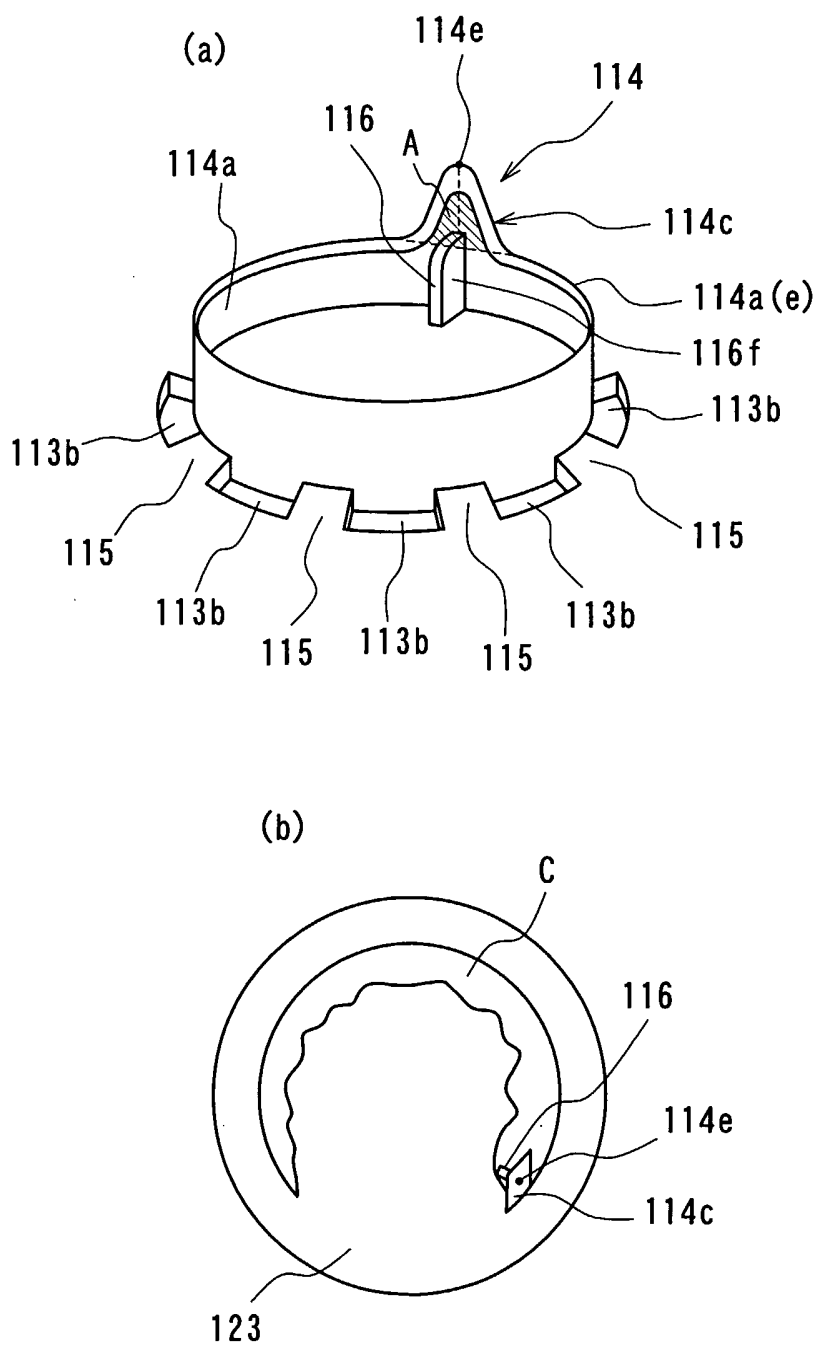
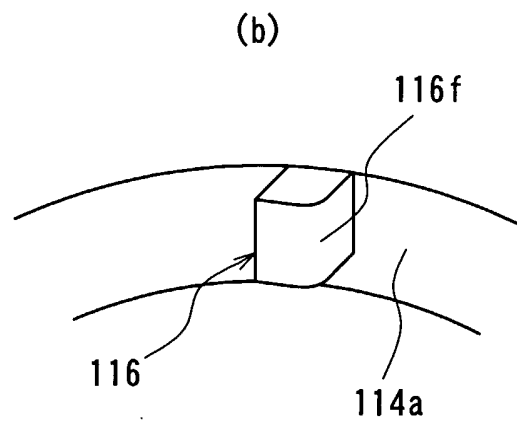
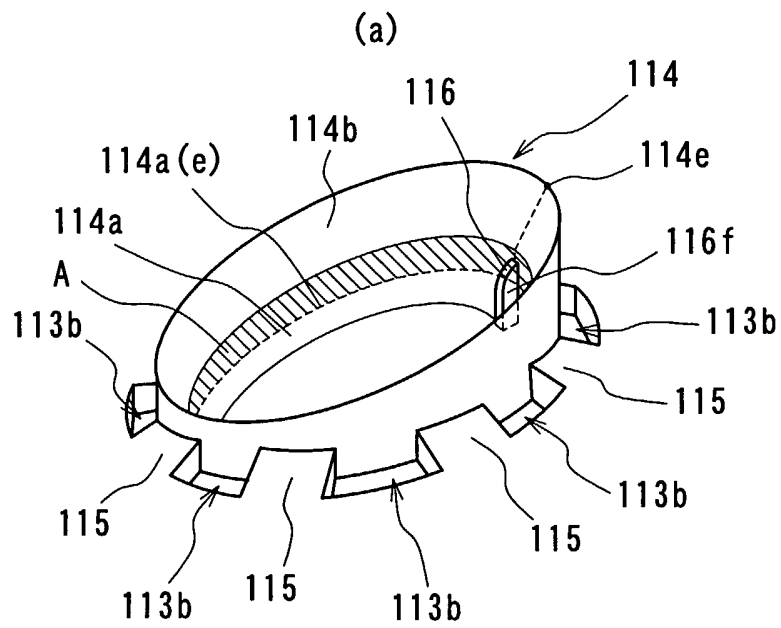

FIG. 5



INTERNATIONAL SEARCH REPORT

International Application No
PCT/JP2005/019939

| A. CLASSIFICATION OF SUBJECT MATTER B65D51/28 | | |
|---|--|---|
| According to International Patent Classification (IPC) or to both national classification and IPC | | |
| B. FIELDS SEARCHED | | |
| Minimum documentation searched (classification system followed by classification symbols) B65D | | |
| Documentation searched other than minimum documentation to the extent that such documents are included in the fields searched | | |
| Electronic data base consulted during the international search (name of data base and, where practical, search terms used) EPO-Internal | | |
| C. DOCUMENTS CONSIDERED TO BE RELEVANT | | |
| Category * | Citation of document, with indication, where appropriate, of the relevant passages | Relevant to claim No. |
| Y | US 6 138 821 A (HSU ET AL) 31 October 2000 (2000-10-31) column 5, line 65 - column 7, line 18; figures 7,8 | 1,2,5 |
| Y | US 2003/089627 A1 (CHELLES GUSTAVO SENNA ET AL) 15 May 2003 (2003-05-15) figure 2 | 1,2,5 |
| A | WO 2004/000667 A (SIG TECHNOLOGY LTD; WEIST, MARIO; HUBER, HANSJOERG; SEELHOFER, FRITZ) 31 December 2003 (2003-12-31) figures 1,4 | 3 |
| A | DE 24 32 290 A1 (WUNSCH, ERICH, 7141 SCHWIEBERDINGEN) 22 January 1976 (1976-01-22) the whole document | 1 |
| <input type="checkbox"/> Further documents are listed in the continuation of box C. | | |
| <input checked="" type="checkbox"/> Patent family members are listed in annex. | | |
| * Special categories of cited documents : | | |
| *A* document defining the general state of the art which is not considered to be of particular relevance *E* earlier document but published on or after the international filing date *L* document which may throw doubts on priority claim(s) or which is cited to establish the publication date of another citation or other special reason (as specified) *O* document referring to an oral disclosure, use, exhibition or other means *P* document published prior to the international filing date but later than the priority date claimed | | *T* later document published after the international filing date or priority date and not in conflict with the application but cited to understand the principle or theory underlying the invention *X* document of particular relevance; the claimed invention cannot be considered novel or cannot be considered to involve an inventive step when the document is taken alone *Y* document of particular relevance; the claimed invention cannot be considered to involve an inventive step when the document is combined with one or more other such documents, such combination being obvious to a person skilled in the art. *&* document member of the same patent family |
| Date of the actual completion of the international search 5 January 2006 | | Date of mailing of the international search report 19/01/2006 |
| Name and mailing address of the ISA European Patent Office, P.B. 5818 Patentlaan 2 NL - 2280 HV Rijswijk Tel. (+31-70) 340-2040, Tx. 31 651 epo nl, Fax: (+31-70) 340-3016 | | Authorized officer Balz, O |

INTERNATIONAL SEARCH REPORT

International Application No
PCT/JP2005/019939

| Patent document cited in search report | | Publication date | Patent family member(s) | Publication date |
|--|---|------------------|-------------------------|------------------|
| US 6138821 | A | 31-10-2000 | AU 6066799 A | 31-05-2001 |
| | | | BE 1013199 A3 | 02-10-2001 |
| | | | CH 694299 A5 | 15-11-2004 |
| | | | DE 19960238 A1 | 21-06-2001 |
| | | | DE 29922866 U1 | 17-02-2000 |
| | | | FR 2802180 A1 | 15-06-2001 |
| | | | GB 2356844 A | 06-06-2001 |
| | | | IT T0991163 A1 | 28-06-2001 |
| | | | JP 3564032 B2 | 08-09-2004 |
| | | | JP 2001261053 A | 26-09-2001 |
| | | | SE 9904722 A | 23-06-2001 |
| | | | SG 89307 A1 | 18-06-2002 |
| | | | US 2003089627 | A1 |
| WO 2004000667 | A | 31-12-2003 | AU 2003233906 A1 | 06-01-2004 |
| | | | BR 0311973 A | 29-03-2005 |
| | | | CA 2485495 A1 | 31-12-2003 |
| | | | CN 1662422 A | 31-08-2005 |
| | | | EG 23441 A | 03-09-2005 |
| | | | EP 1513732 A1 | 16-03-2005 |
| | | | HR 20041162 A2 | 30-04-2005 |
| | | | JP 2005533725 T | 10-11-2005 |
| | | | DE 2432290 | A1 |