

Jan. 2, 1923.

1,440,489

R. V. NORRIS.  
AÉROPLANE.  
FILED SEPT. 21, 1921.

2 SHEETS-SHEET 1

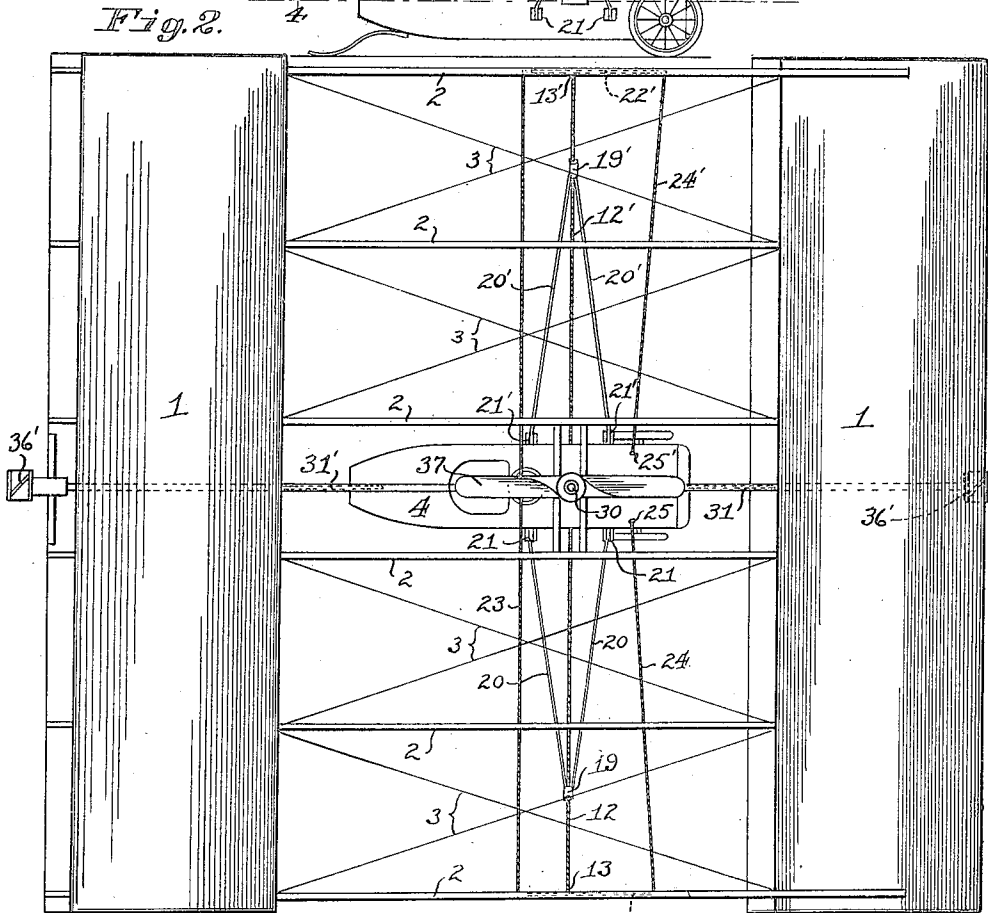
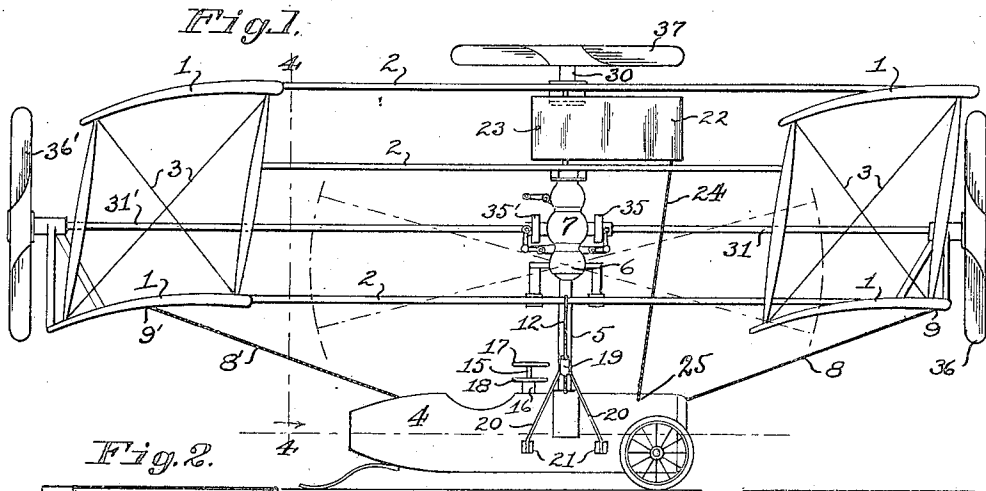
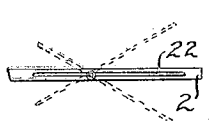

Fig. 3.



Inventor,  
Rolla V. Norris  
By Booth & Booth Attorneys

Jan. 2, 1923.

1,440,489

R. V. NORRIS.  
AEROPLANE.  
FILED SEPT. 21, 1921.

2 SHEETS-SHEET 2

Fig. 4.

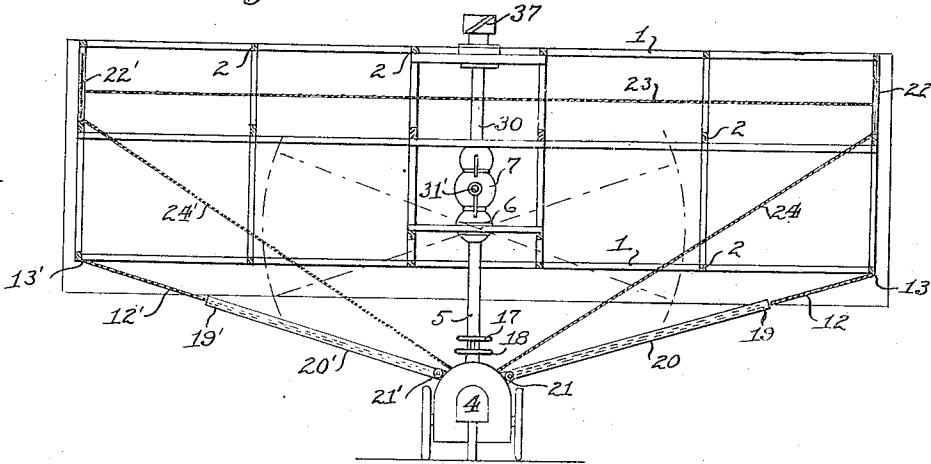

Fig. 5.

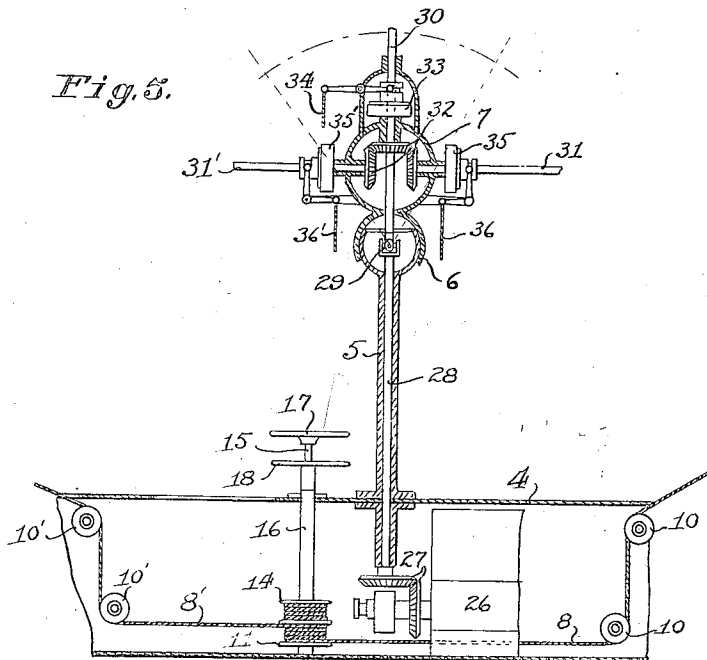
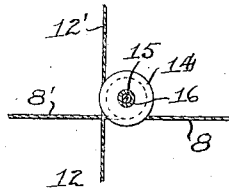

Fig. 6.



Inventor,  
Rolla V. Norris  
Booth & Booth  
attorneys

Patented Jan. 2, 1923.

1,440,489

# UNITED STATES PATENT OFFICE.

ROLLA V. NORRIS, OF PORTERVILLE, CALIFORNIA.

## AEROPLANE.

Application filed September 21, 1921. Serial No. 502,126.

*To all whom it may concern:*

Be it known that I, ROLLA V. NORRIS; a citizen of the United States, residing at Porterville, in the county of Tulare and State of California, have invented certain new and useful Improvements in Aeroplanes, of which the following is a specification.

My invention relates to that class of aeroplanes in which the fuselage is pendulously suspended from the plane-structure and is adapted by its relative movement to provide for controlling the longitudinal and lateral balance and the steering of the machine.

The object of my invention is to provide a simple and effective aeroplane of this type in which the equilibrium control is not left wholly to the automatic pendulous movements of the fuselage but is under the direct control of the aviator, through his discretionary manipulation of the lines connecting the fuselage and plane-structure, whereby their relative automatic movements due to the pendulously suspended fuselage are defined and controlled; and the whole plane-structure thus caused to restore and maintain the equilibrium.

With this and other objects in view, my invention consists in the novel aeroplane which I shall now fully describe by reference to the accompanying drawings, though it is to be understood that while I have herein illustrated my aeroplane in its best form, various changes in construction and arrangement may be made, without affecting the essential features of my invention as defined by my attached claims.

In the drawings—

Fig. 1 is a side elevation of my aeroplane.

Fig. 2 is a plan view of the same.

Fig. 3 is a detailed plan view of one of the rudders.

Fig. 4 is a part sectional rear elevation of the complete aeroplane, taken in the direction of the arrow on the line 4—4 of Fig. 1.

Fig. 5 is a central vertical section, enlarged, of the fuselage and power transmitting mechanism.

Fig. 6 is a detailed sectional plan of the steering gear.

In the drawings, the reference numerals 1 designate lifting planes, which are formed in any suitable and well known manner, and are preferably, though not essentially, ar-

ranged in pairs, as biplanes, one member of each pair being above the other. One set of planes is in front, and the other is in the rear, and horizontal braces 2 and guy wires 3 hold all the planes in their respective positions to form a rigid structure of the form shown in Figs. 1, 2 and 4 of the drawings.

A fuselage 4 is hung from the approximate center of the plane structure, and is capable of swinging movement with respect to said plane structure, to permit it to remain horizontal even though the plane structure be tilted to a considerable angle, either fore and aft or laterally. To permit such relative movement on the part of the fuselage 4, it is hung by a tubular suspension member 5, having a ball and socket connection 6 with a housing member 7, mounted upon the braces 2 approximately midway between the front and rear planes.

The relative movement of the plane structure with respect to the fuselage 4 is controlled by means of four cables. Two of these, indicated by the numerals 8 and 8' in Fig. 1, extend forwardly and rearwardly from the fuselage, and are fastened to the front and rear planes at 9 and 9' respectively, said points of fastening being in the lateral centers of the respective planes. Said cables enter the fuselage at its front and rear ends respectively, and, passing over guide pulleys 10 and 10', Fig. 5, are wound upon a drum 11 in such a manner that, upon rotation of said drum 11, one cable is drawn in and the other paid out, thus tilting the plane structure endwise with respect to the fuselage. If desired, the cables 8 and 8' may be one continuous cable, fastened at its center to the drum 11. The other two cables 12 and 12', Figs. 2 and 4, extend laterally from the fuselage 4, and are fastened, at 13 and 13' respectively, to outermost horizontal braces 2. Said cables 12 and 12' are wound upon a drum 14, Fig. 5, in a manner similar to the cables 8 and 8', so that, by rotation of said drum 14, the plane structure is tilted laterally.

The drum 11 is fixed upon a vertical shaft 15, and the drum 14 is similarly fixed upon a sleeve 16 surrounding said shaft. See Fig. 5. Hand wheels 17 and 18 respectively, are provided for independently turning said shafts and their drums. The lateral cables 12 and 12' pass through guides 19 and 19', Figs. 1 and 2, which are carried upon the

outer ends of arms 20 and 20' respectively, the latter being pivotally connected with the fuselage 4, for vertical movement only, at 21 and 21'. The purpose of said guide arms 5 is to prevent the fuselage from turning, horizontally, with respect to the plane structure, without, however, interfering with its tilting movement.

At the sides of the plane structure, between the front and rear planes, are vertically disposed rudders 22 and 22', Figs. 1 to 4, pivotally mounted for horizontal swinging movement. The rear ends of said rudders are connected together by a horizontal cable 23, and their forward ends are connected with the fuselage 4 by cables 24 and 24', said cables being fastened to the fuselage at 25 and 25' respectively. The rudders 22 and 22' are therefore operated in unison and automatically by the lateral tilting of the plane structure.

The aeroplane is guided entirely by means of the hand wheels 17 and 18. The fuselage is maintained in a horizontal position by its own weight, which is balanced about the suspension member 5. By tilting the plane structure fore and aft, by means of the hand wheel 17 and the cables 8 and 8', the machine is caused to go up or down, according to whether the front of said plane structure is raised or lowered. Similarly, by tilting the plane structures laterally, by means of the hand wheel 18 and the cables 12 and 12', the machine is banked, and at the same time the rudders 22 and 22' are operated to guide the machine into a curve. Said rudders are so proportioned, and so connected with relation to the lateral tilting of the plane structure, that the machine is guided into the approximate degree of curvature for which it is banked, in order to avoid side slipping. The weight of the balanced fuselage, moreover, serves to automatically stabilize the machine.

An engine 26, Fig. 5, is mounted in the fuselage 4, and drives, by means of bevel gears 27, a vertical shaft 28 carried within the tubular suspension member 5. Said shaft 28 has a universal joint 29 in the center of the ball joint 6, and is extended upwardly therefrom as shown at 30, and drives forwardly and rearwardly extending horizontal shafts 31 and 31' by means of bevel gearing 32 inclosed within the housing 7. The vertical shaft 30 is provided with a clutch 33, controlled by any convenient means, as, for example, a cord 34. The horizontal shafts 31 and 31' are similarly provided with clutches 35 and 35' respectively, controlled by cords 36 and 36'. The horizontal shafts 31 and 31' carry propellers 36 and 36' respectively, Figs. 1 and 2, positioned outside the planes 1, for propelling the machine forwardly, and the vertical shaft 30 carries a horizontal propeller 37 for

assisting the rise and retarding the descent of the machine. By manipulating the clutches 33, 35 and 35', any one or all of the propellers may be operated, as desired.

It will be seen from the foregoing that the aeroplane has great inherent stability, not only on account of the swinging suspension of the fuselage, but also because of its position beneath the approximate center of the plane structure. Moreover, the cables 8 and 8' and 12 and 12' are sufficiently strong to support the entire weight of the fuselage, so that even if the suspension member 5 and drive shaft 28 should break or become detached at either end, the fuselage would still be supported by the said cables, and its weight would enable the aviator to still control the machine, at least to a considerable degree, by means of the hand wheels 17 and 18. In such a case, the fuselage would remain right side up, because the cables 8 and 8' and 12 and 12' enter it considerably above its center of gravity, and the machine could be made to glide to a safe landing.

I claim:—

1. An aeroplane comprising a plane-structure formed of connected fore and aft planes; rudders carried by said structure between its fore and aft planes; a fuselage pendulously suspended from the approximate center of said plane structure and adapted for relative swinging movement; lines connecting the fuselage and plane-structure to control said relative movement; means operated by the aviator to control said lines; and lines connecting the fuselage with the rudders for automatically operating them by the relative movement of the fuselage.

2. An aeroplane comprising a plane-structure formed of connected fore and aft planes; rudders carried by said structure between its fore and aft planes; a fuselage pendulously suspended from the approximate center of said plane-structure for relative universal swinging movement; lines connecting the fuselage fore and aft with the front and rear of the plane-structure; lines connecting the sides of the fuselage with the sides of the plane-structure; means operated by the aviator for independently controlling said lines; and lines connecting the fuselage with the rudders for automatically operating them by the relative movement of the fuselage.

3. An aeroplane comprising a plane-structure formed of connected fore and aft planes; a fuselage; a hollow suspension member including a universal joint, said member pendulously suspending the fuselage from the approximate center of the plane-structure; lines connecting the fuselage fore and aft with the front and rear of the plane-structure; lines connecting the sides of the fuselage with the sides of the

plane-structure; means operated by the aviator for independently controlling said lines; a motor carried by the fuselage; a vertical propeller carried at the front of the plane-structure; a vertical propeller carried at the rear thereof; a horizontal propeller carried by the plane structure above its approximate center; and power transmitting connections operating through the hollow suspension member and the axis of its universal joint for driving the propellers.

4. An aeroplane comprising a plane-structure formed of connected fore and aft planes; rudders carried by said structure between its fore and aft planes; a fuselage; a hollow suspension member including a universal joint, said member pendulously suspending the fuselage from the approximate center of the plane-structure; lines connecting the fuselage fore and aft with the

front and rear of the plane-structure; lines connecting the sides of the fuselage with the sides of the plane-structure; means operated by the aviator for independently controlling said lines; lines connecting the sides of the fuselage with the rudders for automatically operating them; a motor carried by the fuselage; a vertical propeller carried at the front of the plane-structure; a vertical propeller carried at the rear thereof; a horizontal propeller carried by the plane structure above its approximate center; and power transmitting connections operating through the hollow suspension member and the axis of its universal joint for driving the propellers.

In testimony whereof I have signed my name to this specification.

ROLLA V. NORRIS.