



(12) **EUROPEAN PATENT APPLICATION**

(43) Date of publication:
30.08.2000 Bulletin 2000/35

(51) Int Cl.7: **F28F 9/26**

(21) Application number: **99830103.0**

(22) Date of filing: **26.02.1999**

(84) Designated Contracting States:
**AT BE CH CY DE DK ES FI FR GB GR IE IT LI LU
MC NL PT SE**
Designated Extension States:
AL LT LV MK RO SI

(72) Inventors:
• **Crippa, Aurelio**
22060 Arosio, Como (IT)
• **Valmacco, Ornello**
28010 Cavaglio d'Agogna, Novara (IT)

(71) Applicant: **FABBRICA MACCHINE CURVATUBI
CRIPPA AGOSTINO S.p.A.**
I-22060 Arosio (Como) (IT)

(74) Representative: **Sutto, Luca, Ing.**
Bugnion S.p.A.,
Viale Lancetti, 19
20158 Milano (IT)

(54) **Modular element for radiators**

(57) A modular element (2) is described which comprises an elongated body (3) at one end (3a) of which a seating (14) is formed for engagement of means consisting of a first half (9) connected to said tubular body (3) and a second half (10) axially integral with the first half (9) and defining with the latter, a rotation axis which is perpendicular to the longitudinal extension axis of the tubular body (3). The two halves (9,10) are coupled with each other in such a manner that they have radial plays capable of compensating for possible machining faults

during the modular element (2) manufacture and/or possible assembling inaccuracies, without the occurrence of repercussions in terms of fluid-tightness. It is also disclosed a radiator (1) consisting of a plurality of modular elements (2) to be coupled with each other and put into fluid communication between a delivery line (5) and an evacuation line (6) of a heating plant for dwelling houses and the like. It is a final object of the present invention a process for manufacturing said modular element (2) and assembling it, so as to form a radiator (1).

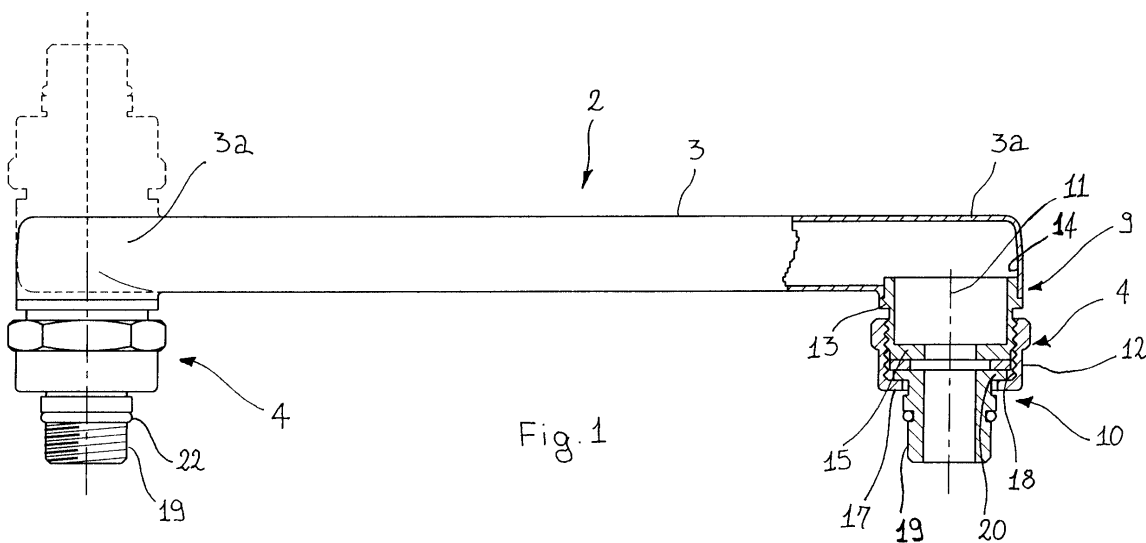

Fig. 1

Description

[0001] The present invention relates to a modular element for radiators intended for heating plants, to a radiator for heating plants and to a process for manufacturing of same.

[0002] More specifically, the invention relates to a new modular element to be used for construction of radiators for heating plants, as well as to a radiator obtained through use of one or more of said modular elements.

[0003] The invention also relates to a process for manufacturing both the above mentioned modular element and a radiator obtained by use of said modular element.

[0004] It is known that radiators for heating plants presently on the market consist of a plurality of modular elements made of cast iron, steel or aluminium alloys for example, that are joined together by connecting elements such as nipples. It is to note that the number of elements and the sizes and shape of each element that will form a radiator can be varied depending on the available installation conditions in terms of available space, thermal power required, and aesthetic effect to be ensured. The elements that are going to form a radiator typically have an upper collector and a lower collector connected by a series of suitably spaced-out columns inside which the heating fluid flows. These columns are of a variable number depending on the element type and typically can be of a number included between 1 and 10 columns. The outer surface of the radiators is then designed for being the widest possible one, consistently with construction problems, in order to achieve the maximum exchange of heat energy with the surrounding environment, bulkiness and other thermal conditions thereof being the same. From the point of view of installation, the different elements constituting the radiator are joined together consecutively, then the radiator thus obtained is connected to a heating plant comprising a heat generator and pipelines bringing hot fluid, consisting of hot water or low-pressure steam for example, to the radiator. The hot fluid passes through the pipelines within the radiator getting progressively cool and then comes out of an evacuation opening provided in the radiator itself.

[0005] While the above radiators are widespread on the market, they however highlight some drawbacks: high production costs, poor operating flexibility and further inconveniences.

[0006] It is in fact to note that the elements forming the radiators briefly mentioned above are usually made by casting with use of appropriate moulds. As a result, when elements of differentiated shapes and sizes are wished to be made, arrangement of different moulds is required, which obviously brings about cost increases.

[0007] It is also important to note that, since as regards assembling a precise alignment of the parts of each element to be connected with those of the consecutive element is needed, a great accuracy is required

during production in order to avoid substantial impossibilities of carrying out assembling.

[0008] It is apparent that ensuring a geometric accuracy is very difficult, above all in the cases in which the radiator has elements of relatively big sizes.

[0009] In addition, although clearly a modular construction offers the possibility of disassembling the different elements, it is also to point out that actually the sizes of each element are not so reduced that an easy handling and transportation of same is ensured.

[0010] Taking into account the sizes of each element forming the radiator, that are often rather important, and the necessity to ensure a great construction accuracy in making it in order to enable an easy assembling of same, production costs of radiators are high and the relative assembling is often difficult.

[0011] In addition to the above, it is to note that surely the radiators of the above described type have a questionable aesthetic aspect that often does not meet the architectonic or furnishing requirements that are wished for some types of environments. It is exactly due to their own conformation that radiators of the above described type, once installed, look like rigid non-deformable bodies which moreover are unable to define rest or support surfaces of easy use that surely would be advantageous in particular rooms such as bathrooms or bedrooms.

[0012] As an alternative to the above described radiators, also radiators of a second typology have recently appeared on the market. They are made up of tube bundles in sight, disposed parallelly of each other or coil-wise, for example. These radiators are usually obtained by end welding of several consecutive tubular elements so as to define the desired shape (in the form of a ladder or a coil, for example, as mentioned above). Still from a construction point of view and as an alternative solution to welding or gluing, in particular in cases in which pipes of reduced section or easy deformability are concerned, manufacture of coil radiators by consecutive bending of a single tubular element has been carried out. This type of radiator is presently appreciated, due to its good aesthetic features that can be adapted to the consumers' taste either by giving the section appropriate shapes (round, elliptic, oval forms or still others) or by carrying out appropriate relative arrangements of the pipes or pipe portions defining the radiator. In addition to the above qualities, it is however to point out that radiators having pipes in sight highlight some negative aspects as well.

[0013] One of the main drawbacks of the above described radiators is the complete absence of modular structures. Practically, coil radiators or radiators having a ladder-shaped structure are given particular sizes by the manufacturer, so that they may provide predetermined thermal powers. Therefore, in order to meet the most varied operating requirements, these radiators are made in a plurality of different shapes and sizes. Due to the fact that radiators of the second mentioned typology are rigid and preassembled structures since production,

it is apparent that this negatively affects transportation of same and makes assembling not very practical.

[0014] It is also to note that, if on installation the radiator would have sizes making it impossible to adapt the same to the connections provided on the wall, replacement of the whole radiator or modification of the wall connections would be necessary, which would bring about clear inconveniences as building works would be necessary.

[0015] Finally, the last-mentioned radiators are at all events scarcely able to define support regions for towels, linen, garments, etc. in that pipes defining them are disposed in mutual side by side relationship in a common lying plane.

[0016] After the above statements, it is a fundamental object of the present invention to provide a new modular element for manufacturing of radiators as well as a new radiator obtained by assembling a plurality of said modular elements, which are capable of substantially obviating all the above mentioned drawbacks.

[0017] In particular it is an object of the present invention to provide a modular element for manufacturing of radiators for heating plants which is of easy and cheap production and easy assembling when installation of a radiator formed of a plurality of said modular elements is to be carried out.

[0018] Another object of the invention is to provide a modular element capable of being manufactured with large working tolerances while enabling an efficient assembling with contiguous modular elements so as to define a radiator.

[0019] It is a further object of the invention to provide a new radiator obtained by assembling some modular elements being the object of the invention, which is of easy adaptability to the installation requirements that are to be met each time, and which can have a deformable structure, for complying both with practical requirements such as defining rest seatings for garments or other items and with aesthetic requirements that in some cases may occur.

[0020] The objects pointed out above are substantially achieved by a tubular element for radiators in heating plants and a radiator for heating plants in accordance with the appended claims 1 to 17.

[0021] It is also an object of the invention to provide a process enabling said radiator and tubular element for radiators to be manufactured in an efficient manner from the point of view of production, and at reduced costs.

[0022] The last-mentioned object is achieved by a process for manufacturing of tubular elements and radiators for heating plants in accordance with that which is described in the process claims 18 to 21.

[0023] Further features and advantages will become more apparent from the detailed description of some preferred, but non-exclusive, embodiments of a modular element and a radiator for heating plants in accordance with the invention.

[0024] In the following description a preferential alter-

native embodiment of a process for manufacturing of said modular element and radiator in accordance with the invention will be also illustrated. Such a description will be taken hereinafter with reference to the accompanying drawings, given by way of non-limiting example, in which:

- Fig. 1 shows a longitudinal section of a possible embodiment of a modular element in accordance with the invention;
- Fig. 2 shows a fragmentary section of two modular elements in accordance with the invention, connected with each other at their ends;
- Fig. 3 shows a first embodiment of a radiator for heating plants in accordance with the invention in which use is made of a plurality of modular elements of the type shown in Fig. 1;
- Fig. 4 is a view of the radiator in Fig. 3 in which some modular elements are rotated through 90°;
- Fig. 5 is a bottom plan view of a second embodiment of a radiator in accordance with the invention in which use is made of the modular elements shown in Fig. 1, for example; and
- Fig. 6 is a fragmentary sectional view taken along line VI-VI in Fig. 5.

[0025] With reference to the accompanying drawings and in particular to Figs. 3 to 6, a first and a second embodiments of radiators 1 for heating plants in accordance with the present invention are shown.

[0026] In more detail, radiator 1 shown in Figs. 3 and 4 comprises a plurality of modular elements 2 consecutively connected and brought into fluid communication with each other. It is to note that each modular element 2 forming the radiator has an elongated tubular body 3, at one end 3a of which removable engagement means 4 is provided for carrying out a fluid connection between such one modular element and the consecutive modular element.

[0027] Clearly, in the chain of modular elements thus made an inlet modular element and an outlet modular element are defined, which are connected at one end thereof with the delivery line 5 and the evacuation line 6 of the heating plant, respectively.

[0028] In the embodiment shown in Figs. 5 and 6 a radiator is shown which comprises a plurality of modular elements 2 of the same type as illustrated in Figs. 3 and 4, which elements are however disposed in substantial parallel relationship with each other and each have one end put into fluid communication, by the removable engagement means 4, with a chamber 7 of a lower collector body 8 and one end opposite to the preceding one which, through the removable engagement means, is put into fluid communication as well with a chamber of an upper collector body (the upper portion of the radiator referred to in Figs. 5 and 6 is not shown, in that it is substantially similar to the lower portion thereof).

[0029] These collector bodies will be conventionally

connected with a delivery line and an evacuation line of the heating plant respectively, so as to enable hot-fluid circulation through the tubular bodies 3 of the radiator.

[0030] It is to note that, while the modular elements forming the radiators shown in the accompanying drawings have substantially rectilinear tubular bodies, this must not be intended in a limiting sense.

[0031] In fact, the tubular bodies can also have a U-shaped or S-shaped conformation and be consecutively engaged with each other so as to define spatially-deformable articulated structures.

[0032] In particular and by way of example only, by connecting a plurality of U-shaped elements through means 4, a spatially-deformable articulated structure will be obtained which can be displaced between many operating conditions of greater or lower bulkiness, while its surface of heat exchange will be maintained always constant.

[0033] In more detail, as regards structure, it is to note that each modular element 2 has at least one end 3a (Figs. 2, 3 and 4) at which said removable engagement means 4 is provided or, as in the case in Figs. 1, 5 and 6, both ends are provided with this removable engagement means 4 for connection to respective collectors.

[0034] In an original manner, the above mentioned removable engagement means comprises at least one half 9 which, under operating conditions for assembling of the modular element so as to define a radiator (see both the example in Figs. 3 and 4 and the example in Figs. 5 and 6), is integral with the end of the elongated body. The engagement means 4 also comprises a second half 10 which, under operating conditions for assembling of the modular element, is axially integral with the first half and with the latter defines a relative rotation axis 11 between the first and second halves 9, 10, which is directed transversely and in particular perpendicularly of the longitudinal extension axis of the tubular body. Both the first and second halves 9, 10 are of tubular conformation to enable the fluid from the tubular body to pass therethrough.

[0035] Half 9 of the engagement means 4 comprises, as shown in particular in Figs. 1 and 2, a connecting body 12 removably engaged with the end 3a of the elongated body after interposition of an auxiliary connection element 13, of tubular conformation as well, welded to an attachment seating 14 provided at the end 3a of the elongated body. As can be viewed from the drawings, the auxiliary connection element 13 is fastened to the attachment seating 14 by welding and is provided with a radially inner lip 15, disposed away from said end 3a of the tubular body, which lip under operating conditions defines a flat locating surface for a sealing element 16, as better clarified in the following.

[0036] The portion of the auxiliary connection element 13 which is external to the attachment seating has a cylindrical shape and is provided with an outer screw thread for receiving the connecting body 12, as already said, by removable fitting. For the purpose, said body

has a substantially U-shaped conformation and a substantially cylindrical inner surface provided with a screw thread adapted to mate the thread of the auxiliary connection element 13. As can be seen in Figs. 1 and 2 for example, the connecting body 12, away from the end 3a of the tubular body has an axial-abutment lip 17 delimiting an opening to enable passage of fluid and defining a housing seat 18; a first portion of an interconnecting element 19 of tubular form as well, is fitted in said housing seat 18. Said interconnecting element 19 has an axial-abutment ridge 20 cooperating with said lip 17 so as to ensure integrity in an axial direction of the interconnecting element 19 with the connecting body 12 and therefore with the end 3a of the tubular body when these elements are assembled together. A second portion of the interconnecting element 19, coaxial with the first portion and of tubular conformation as well in order to ensure passage of fluid through the assembly of the engagement means, emerges from said housing seat 18 to ensure a possibility of connection either with a consecutive modular element (Fig. 2), or with a delivery line 5 or evacuation line 6 of the heating plant, or with a collector 8 of a radiator of which this modular element is part.

[0037] Advantageously, the axial-abutment ridge 20 associated with the first portion of the interconnecting element 19 that, as said, is accommodated within the housing seat 18 has a lower radial bulkiness than the housing seat itself, in order to enable a predetermined radial play between the interconnecting element 19 and the connecting body 12.

[0038] Still for the purpose of ensuring this play, a connecting collar 21 between the first and second portions of the interconnecting element 19 (which collar crosses the opening delimited by lip 17) has a lower radial bulkiness than the opening defined by lip 17. As clearly shown in Fig. 2, the attachment seating 14 provided at the end 3a of the tubular body, the auxiliary connection element 13 engaged by welding with the attachment seating 14, the connecting body 12 screwed down on the auxiliary connection element 13, the interconnecting element 19 partly fitted in the housing seat 18 and the housing seat itself are disposed coaxially with each other along a symmetry axis which is coincident with said axis 11.

[0039] This symmetry axis is also the axis of relative rotation between the interconnecting body 19 and the connecting body 12. As can be seen, the interconnecting body 19, at its second portion, has a screw thread, in this case a male thread, capable of engaging with a corresponding end provided with a female screw thread formed in a following modular element (Fig. 2) or with a female screw thread formed in the collector body 8 to which several modular elements of the above described type are connected.

[0040] Still with reference to the second portion of the interconnecting element 19, it is to note that an auxiliary annular ridge is therein defined which is arranged to re-

ceive a sealing ring 22 in abutment, which ring ensures the necessary fluid-tightness for connection between the second portion of the interconnecting element 19 and a following modular element, for example.

[0041] As diagrammatically shown in Fig. 1, the modular elements can be manufactured in such a manner that they have one attachment seating 14 at both ends. In this case, both attachment seatings 14 will be obtained by permanent set, will have a substantially cylindrical conformation and will be each arranged for accommodating corresponding removable engagement means 4 for connection with respective collectors, as shown in Figs. 5 and 6.

[0042] Alternatively, the attachment seatings 14, possibly formed in the opposite ends of the elongated body, will be able to extend along opposite sides of the elongated body itself, as shown in chain line in Fig. 1.

[0043] According to a further alternative embodiment, not shown, should tubular elements having U-shaped (or S-shaped) tubular bodies be used, i.e. with a U-shaped (or S-shaped) longitudinal symmetry axis, the engagement means could be directly connected to the end or ends of the tubular body which would not require further deformations since the attachment seating is defined as a result of the U-shaped (or S-shaped) conformation of the whole tubular body.

[0044] After describing the modular element in accordance with the invention and the radiators to be manufactured by assembling of this modular element, the process for manufacturing of a modular element in accordance with the invention, which is an object of the invention as well, will be now described.

[0045] First the rectilinear tubular body is manufactured by extrusion for example, or a curvilinear tubular body (having an S-shaped, U-shaped or different conformation, for example) is manufactured by extrusion and subsequent bending. The tubular body can be made of steel, aluminium, brass or another material adapted for the purpose. In case of rectilinear pipes for producing modular elements of the type herein illustrated, a pipe bending machine or a machine tool for machining end portions of pipes is used. By this machine at least one end of the tubular body is machined that, being permanently set, defines the cylindrical attachment seating 14 intended for receiving the above mentioned removable engagement means 4. From a practical point of view it is to note that the above described deformations are quite identical for example with those necessary for manufacturing taps and fittings from tubular bodies; therefore the operations described for producing a conveniently deformed elongated body for accomplishing the modular element in reference do not involve employment, on the part of tap and fittings manufacturers, of apparatus different from those already traditionally in use.

[0046] Once the attachment seating 14 has been made, the axis 11 of which will be disposed transversely of the longitudinal extension axis of the elongated body

and in particular perpendicular to the axis of said body (in the case of rectilinear pipes), coupling of the attachment seating 14 with the above described removable engagement means 4 is carried out.

[0047] In case of pipes previously bent into a U-shaped or S-shaped conformation, means 4 is directly brought into engagement with the attachment seating 14, without further deformation or permanent set operations being required.

[0048] Practically, first manufacturing of the connection element 13, the connecting body 12 and the interconnecting element 19 is carried out, if these pieces have not been previously made. Then coupling of the latter with the attachment seating 14 is carried out. In more detail, the following operations are executed: fastening, by welding for example, of the connection element 13 to said attachment seating 14, screwing down of the connecting body 12, with the interconnecting element 19 coupled therewith, on said auxiliary connection element 13, so as to define the housing seat 18. During this operation, the necessary annular seal 16 will be inserted between the interconnecting element 19 and the auxiliary connection element 13.

[0049] A further seal 22 is also provided at the second portion of the interconnecting element 19. This step can be obviously carried out either before or after the engagement means is associated with the attachment seating.

[0050] The invention achieves important advantages.

[0051] First of all, it is to note that due to the structure of the modular element, radiators of any configuration can be achieved which will meet both thermal and aesthetic requirements of any nature.

[0052] In addition, the marked modular character of the structure characterizing the modular element in reference enables radiators even of big sizes to be manufactured without difficulties arising on production.

[0053] In fact, the modular element in question can be manufactured by mere bending operations and subsequent assembling of components. By virtue of the particular structure of the engagement means to be associated with one or both ends of the modular element, the latter also has a good capability of counterbalancing possible machining errors by means of the radially admissible plays between the first and second portions.

[0054] The above is achieved without any inconveniences as regards tightness or difficulties in assembling.

[0055] From the point of view of transport, the structure of the modular element ensures a comfortable handling and packages in minimum spaces, which thing surely is not negligible.

[0056] The possibility of carrying out relative rotatory movements about the rotation axis defined by the engagement means between a modular element and the following one enables rest surfaces for garments, towels and the like to be made available, in particular in radiators made up of several consecutive elements (Figs. 3 and 4), which is very advantageous from a practical

point of view in rooms such as bathrooms, bedrooms, etc.

[0057] The possibility of carrying out relative rotations between the modular elements enables the cleaning operations of the radiator to be greatly simplified. On servicing, should one or more modular elements look damaged or clogged, the modular structure of the radiator would enable an easy dismantling and replacement of the damaged elements alone.

Claims

1. A modular element for radiators intended for heating plants, comprising:

- an elongated tubular body (3);
- removable engagement means (4) associated with at least one end (3a) of the tubular body (3), capable of making a direct or indirect fluid-tight connection of one modular element (2) with the consecutive modular element or with a delivery line (5) or an evacuation line (3) of the heating plant,

characterized in that the engagement means (4) comprises at least one half (9) which, under operating conditions for assembling of the modular element, is integral with the end (3a) of said elongated body, and a second half (10) which, under operating conditions for assembling of the modular element, defines with said modular element a relative rotation axis (11) between the first and second halves.

2. A modular element as claimed in claim 1, characterized in that the second half (10), under operating conditions for assembling of the modular element, is axially integral with the first half (9).

3. A modular element as claimed in claim 1 or 2, characterized in that said first half (9) of the engagement means (4) comprises:

- a connecting body (12) of tubular conformation removably in engagement with said end (3a) of the elongated body and having an axial-abutment lip (17) away from said end, said connecting body (12) also defining a housing seat (18);

and in that said second half (10) comprises:

- an interconnecting element (19) of tubular shape as well, having one portion fitted in said housing seat (18) and provided with an axial-abutment ridge (20) arranged to cooperate with said lip (17), and a second portion, emerging from said housing seat (18), to be connected with a consecutive modular element, a delivery

line or an evacuation line of the heating plant.

4. A modular element as claimed in claim 3, characterized in that the axial-abutment ridge (20) associated with the first portion of the interconnecting element (19) has a lower radial bulkiness than said housing seat (18), to enable a predetermined radial play between the interconnecting element (19) and the connecting body (12).

5. A modular element as claimed in claim 1, characterized in that said tubular body has a rectilinear U-shaped, S-shaped or differently-shaped extension.

6. A modular element as claimed in claim 2, characterized in that said second portion of the interconnecting element (19) is provided with an annular ridge defining a seating for receiving at least one sealing ring (22).

7. A modular element as claimed in anyone of the preceding claims, characterized in that an attachment seating (14) is formed at said at least one end (3a) of the tubular body (3), which seating (14) is obtained by permanent set and has a substantially cylindrical conformation the axis (11) of which is transverse to the longitudinal extension axis of the elongated body, said attachment seating (14) receiving the first half (9) of the engagement means (4) into engagement.

8. A modular element as claimed in claims 3 and 7, characterized in that said modular element (2) further comprises an auxiliary connection element (13) of tubular shape as well, welded to said end (3a) of the elongated body at said attachment seating and arranged to receive said connecting body (12) into removable engagement.

9. A modular element as claimed in claim 8, characterized in that said auxiliary connection element (13) has, away from said end, a radially-inner lip (15) intended for being located, under operating conditions of the modular element, at the inside of said housing seat (18) and facing said axial-abutment ridge (20) of the interconnecting element (19).

10. A modular element as claimed in claim 9, characterized in that it comprises at least one annular sealing element (16) operatively interposed between the lip (15) of the auxiliary connection element (13) and the axial-abutment ridge (20) of the interconnecting element (19).

11. A modular element as claimed in anyone of the preceding claims, characterized in that the elongated body comprises an attachment seating (14) at both ends thereof, each of said attachment seatings (14)

being obtained by permanent set and having a substantially cylindrical conformation the axis of which is transverse to the longitudinal extension axis of the elongated body (3).

12. A modular element as claimed in claim 11, characterized in that the attachment seatings (14) provided in the elongated body (3) extend along one and the same side of the elongated body or on opposite sides of same.

13. A radiator intended for heating plants, characterized in that it comprises a predetermined number of modular elements (2) of the type described in any one of the preceding claims, operatively connected and put into fluid communication with each other between a fluid delivery line (5) and a fluid evacuation line (6).

14. A radiator as claimed in the preceding claim, characterized in that it comprises at least one collector body (8) provided with a predetermined number of connection ports, each intended for receiving said removable engagement means (4) so as to create a fluid communication between each tubular body (3) and a chamber (7) defined within said collector.

15. A radiator as claimed in claim 14, characterized in that said connection ports can removably engage said second portion of the interconnecting element (19).

16. A radiator as claimed in claim 14, characterized in that said collector comprises at least one passage intended for bringing said chamber into fluid communication with the delivery line (5) or evacuation line (6) of the heating plant of which the radiator is part.

17. A radiator as claimed in claim 14, characterized in that it comprises a further collector body having a predetermined number of connection ports as well, each intended for receiving the removable engagement means (4) associated with said elongated body (3).

18. A radiator as claimed in claim 13, characterized in that said modular elements (2) are directly connected one after the other, the elongated bodies (3) of each modular element being able to angularly oscillate about the rotation axis (11) defined between the first and second halves of the means (4) for engagement of each elongated body with the following one.

19. A process for manufacturing a modular element as claimed in one or more of claims 1 to 11, characterized in that it comprises the following steps:

- preparing a tubular body (3), by extrusion for example;
- machining, by a permanent set operation, at least one end (3a) of said tubular body (3) to define an attachment seating (14) having a substantially cylindrical conformation the axis of which is disposed transversely of the longitudinal extension axis of the elongated body;
- mating the attachment seating (14) thus obtained with removable engagement means (4) comprising a first half which is made integral with the end (3a) of the elongated body and a second half which is coupled with the first half in such a manner that it appears to be axially integral with the latter and so as to define with said first half, a relative rotation axis (11) transverse to the longitudinal extension axis of the elongated body.

20. A process as claimed in the preceding claim, characterized in that application of said removable engagement means (4) to the end of the elongated tubular body comprises the following sub-steps:

- fastening, by welding for example, the auxiliary connection element (13) to said attachment seating (14);
- coupling the connecting body (12) with the interconnecting element (19);
- coupling the connecting body (12) with the auxiliary connection element (13).

21. A process as claimed in claim 20, characterized in that before carrying out coupling of the connecting body (12) with the auxiliary connection element (13), insertion of an annular sealing element (16) between the radially inner lip (15) and the axial-abutment ridge (20) is provided.

22. A process for manufacturing a radiator as claimed in one or more of claims 12 to 17, characterized in that it comprises the following steps:

- arranging a predetermined number of modular elements (3); and
- connecting said modular elements with each other or with a collector body (8) by said engagement means (4).

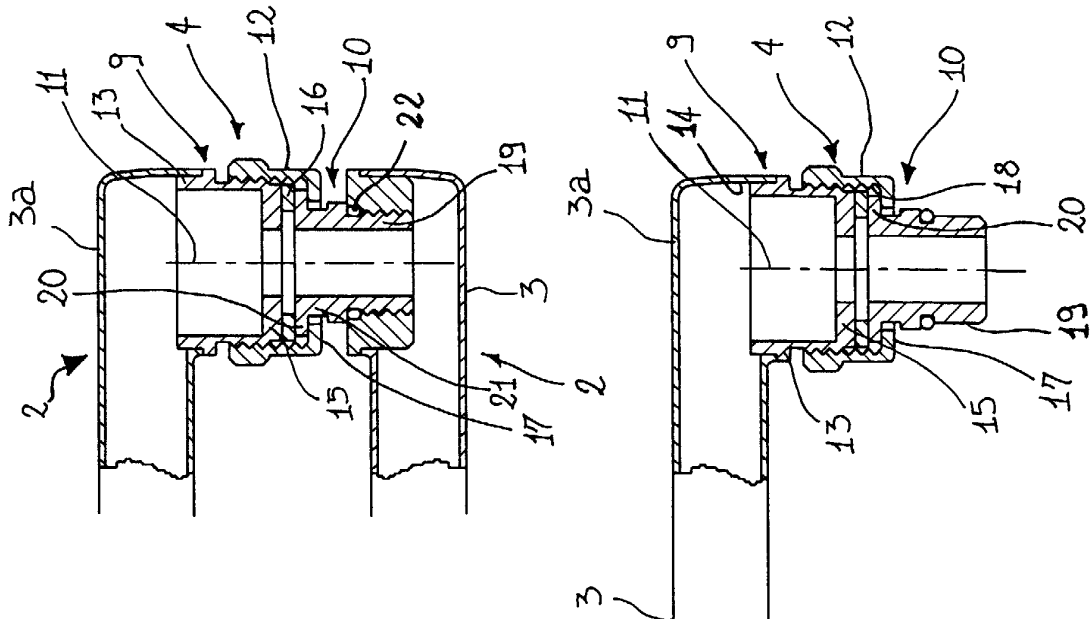
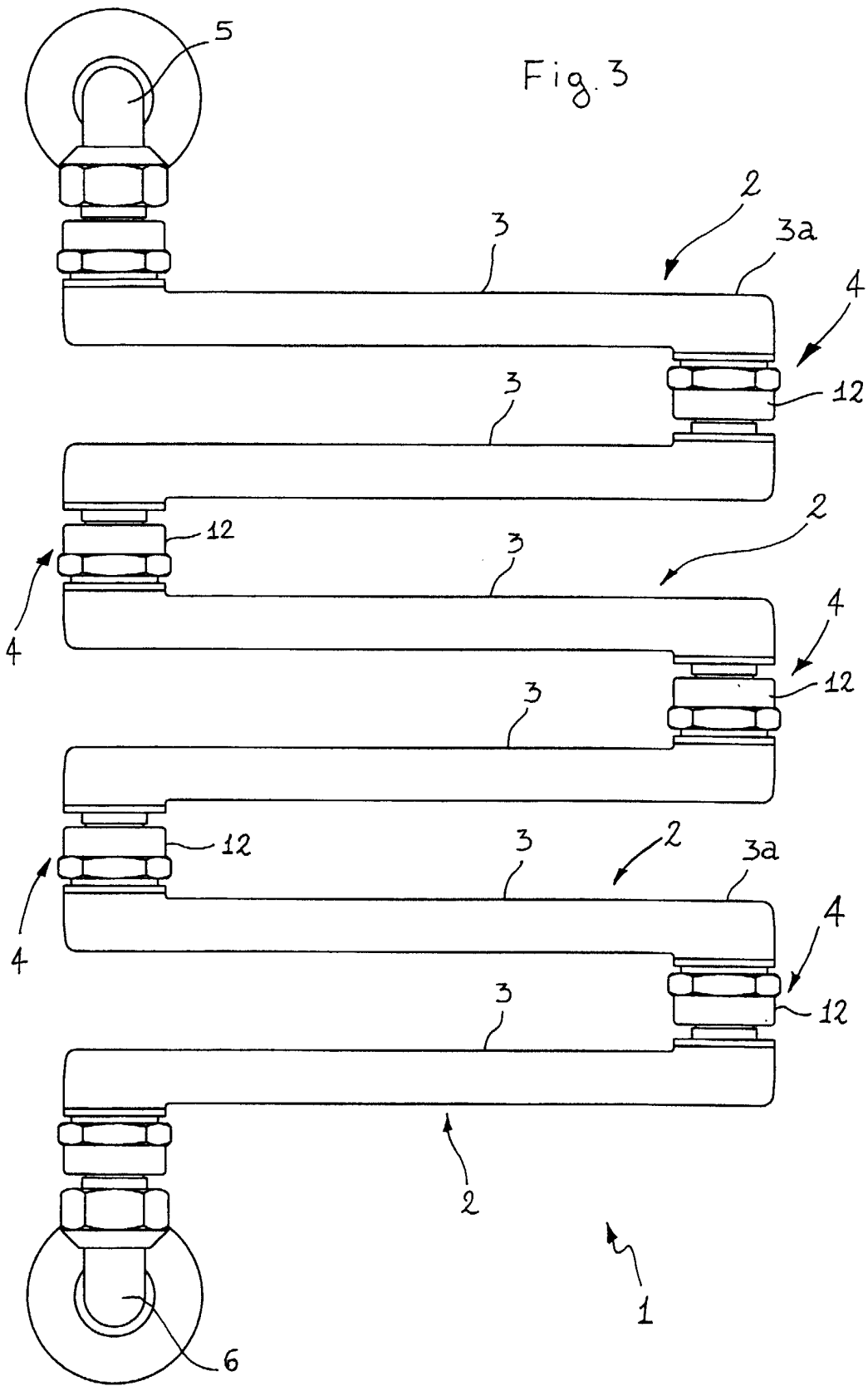
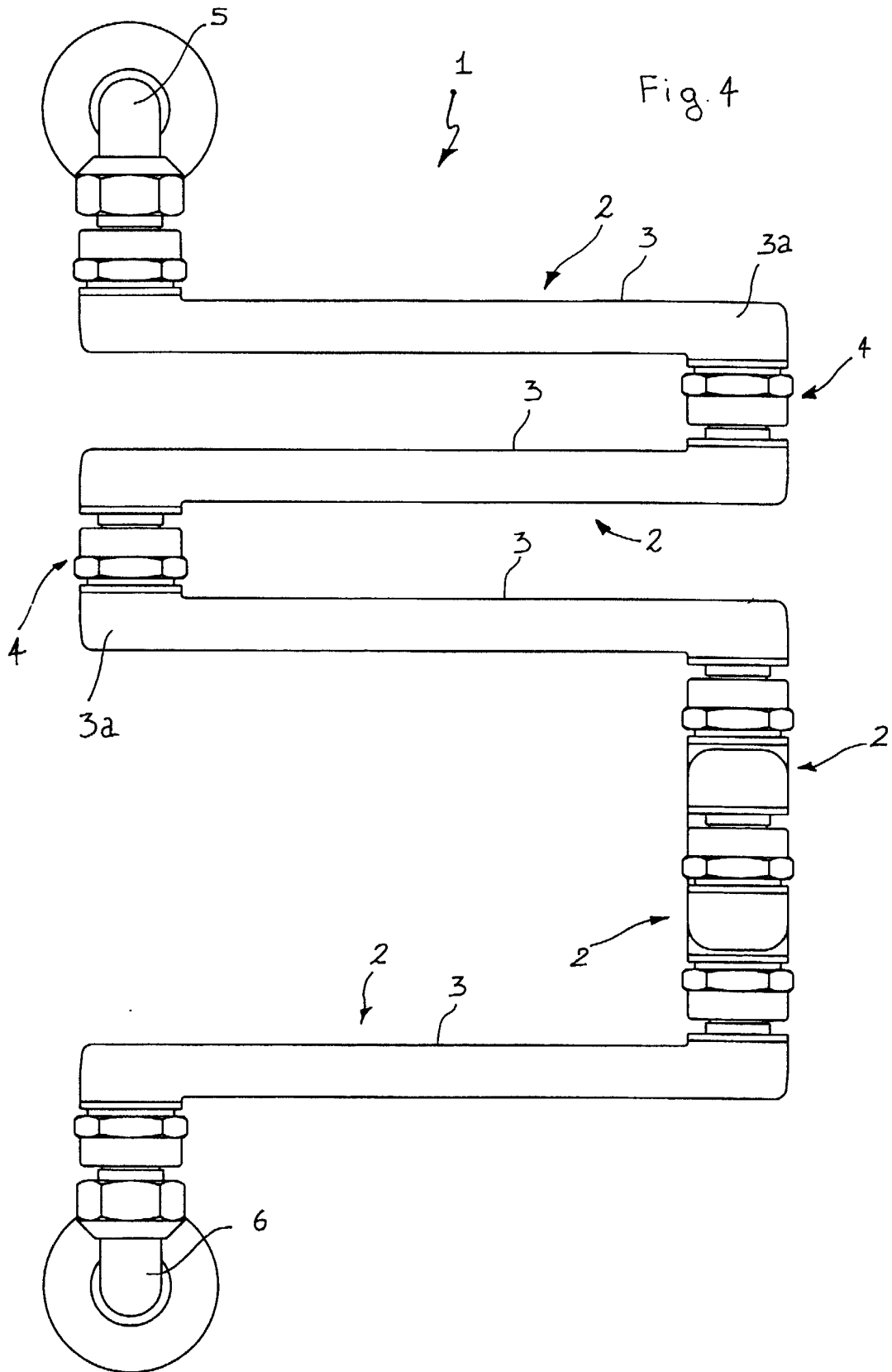
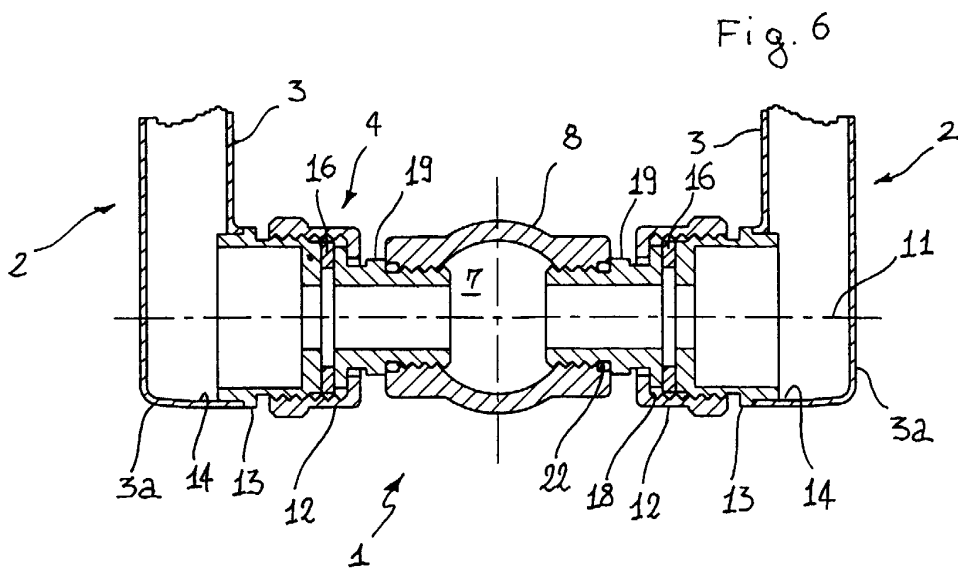
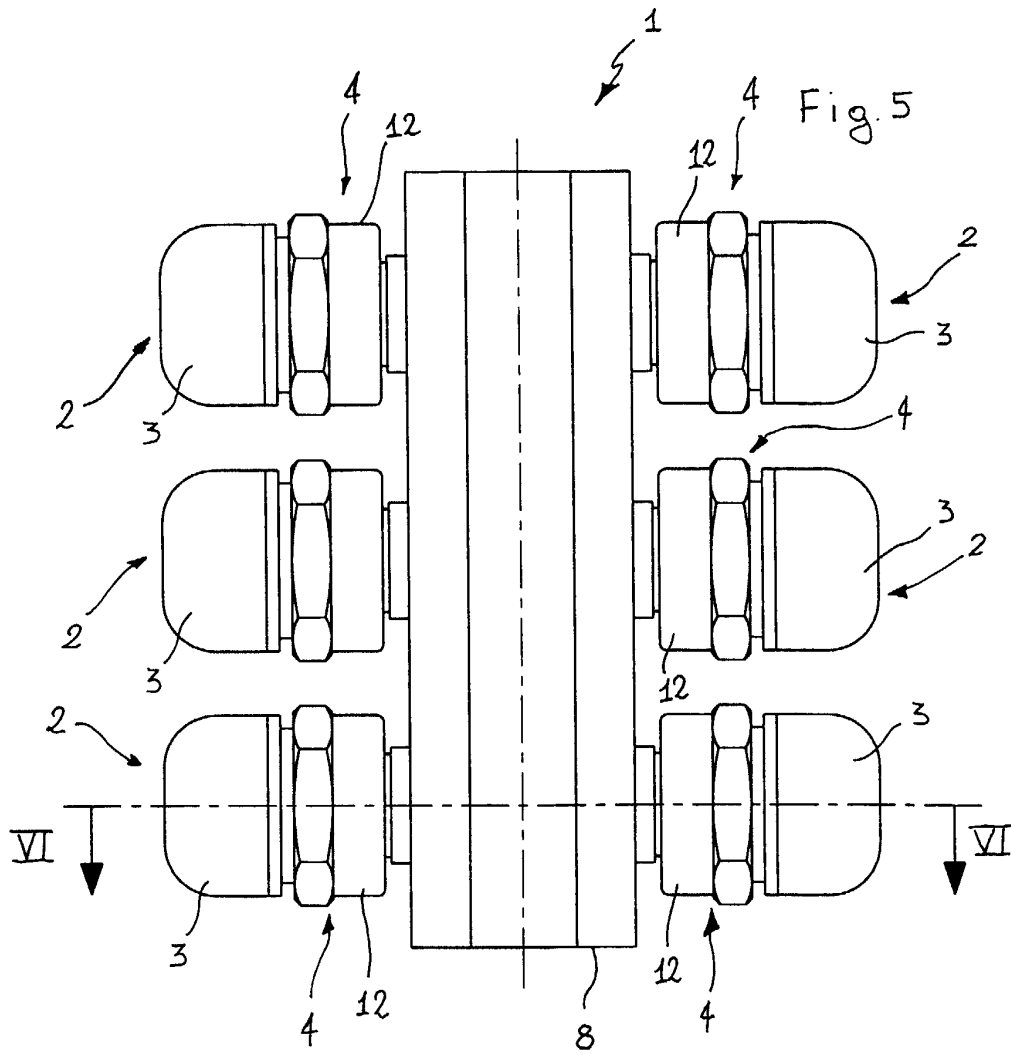

Fig. 2

Fig. 1









European Patent
Office

EUROPEAN SEARCH REPORT

Application Number
EP 99 83 0103

DOCUMENTS CONSIDERED TO BE RELEVANT			
Category	Citation of document with indication, where appropriate, of relevant passages	Relevant to claim	CLASSIFICATION OF THE APPLICATION
Y	BE 771 223 A (LION RAPIDE N V SA) 16 December 1971 (1971-12-16) * page 7, last paragraph - page 13, paragraph 1; figures * ---	1-22	F28F9/26
Y	DE 202 591 C (HERMANN BUYTEN) 5 October 1908 (1908-10-05) * the whole document * ---	1-22	
A	GB 2 294 754 A (NAGI BALVINDERJIT SINGH) 8 May 1996 (1996-05-08) * the whole document * ---	1	
A	BE 818 748 A (ETABLISSEMENTS THOMAS DEFAWES) 2 December 1974 (1974-12-02) * figure 3 * ---	1	
A	BE 838 203 A (HEATING KINGS) 28 May 1976 (1976-05-28) * figures * -----	1	
			TECHNICAL FIELDS SEARCHED
			F28F
The present search report has been drawn up for all claims			
Place of search THE HAGUE		Date of completion of the search 28 July 1999	Examiner Van Dooren, M
CATEGORY OF CITED DOCUMENTS X : particularly relevant if taken alone Y : particularly relevant if combined with another document of the same category A : technological background O : non-written disclosure P : intermediate document		T : theory or principle underlying the invention E : earlier patent document, but published on, or after the filing date D : document cited in the application L : document cited for other reasons & : member of the same patent family, corresponding document	

EPO FORM 1503 03.82 (P04C01)

**ANNEX TO THE EUROPEAN SEARCH REPORT
ON EUROPEAN PATENT APPLICATION NO.**

EP 99 83 0103

This annex lists the patent family members relating to the patent documents cited in the above-mentioned European search report. The members are as contained in the European Patent Office EDP file on
The European Patent Office is in no way liable for these particulars which are merely given for the purpose of information.

28-07-1999

Patent document cited in search report	Publication date	Patent family member(s)	Publication date
BE 771223 A	16-12-1971	NONE	
DE 202591 C		NONE	
GB 2294754 A	08-05-1996	NONE	
BE 818748 A	02-12-1974	NONE	
BE 838203 A	28-05-1976	NONE	

EPO FORM P0459

For more details about this annex : see Official Journal of the European Patent Office, No. 12/82