

(19) World Intellectual Property Organization
International Bureau



(43) International Publication Date
30 July 2009 (30.07.2009)

PCT

(10) International Publication Number
WO 2009/094485 A1

- (51) International Patent Classification:
C12N 1/20 (2006.01) C12P 11/00 (2006.01)
C12P 21/06 (2006.01)
- (21) International Application Number:
PCT/US2009/031737
- (22) International Filing Date: 22 January 2009 (22.01.2009)
- (25) Filing Language: English
- (26) Publication Language: English
- (30) Priority Data:
61/022,804 22 January 2008 (22.01.2008) US
61/059,256 5 June 2008 (05.06.2008) US
- (71) Applicant (for all designated States except US): GENOMATICA, INC. [US/US]; 10520 Wateridge Circle, San Diego, CA 92121 (US).
- (72) Inventors; and
- (75) Inventors/Applicants (for US only): BURK, Mark [US/US]; 12634 Intermezzo Way, San Diego, CA 92130 (US). SCHILLING, Christophe, H. [US/US]; 1254-G El Camino Real, San Diego, CA 92130 (US). BURGARD, Anthony [US/US]; 237 Walker Crossing, Bellefonte, PA 16825 (US). TRAWICK, John, D. [US/US]; 10520 Wateridge Circle, San Diego, CA 92121 (US).

- (74) Agent: GAY, David; McDermott, Will & Emery LLP, 11682 El Camino Real, Suite 400, San Diego, CA 92130-2047 (US).
- (81) Designated States (unless otherwise indicated, for every kind of national protection available): AE, AG, AL, AM, AO, AT, AU, AZ, BA, BB, BG, BH, BR, BW, BY, BZ, CA, CH, CN, CO, CR, CU, CZ, DE, DK, DM, DO, DZ, EC, EE, EG, ES, FI, GB, GD, GE, GH, GM, GT, HN, HR, HU, ID, IL, IN, IS, JP, KE, KG, KM, KN, KP, KR, KZ, LA, LC, LK, LR, LS, LT, LU, LY, MA, MD, ME, MG, MK, MN, MW, MX, MY, MZ, NA, NG, NI, NO, NZ, OM, PG, PH, PL, PT, RO, RS, RU, SC, SD, SE, SG, SK, SL, SM, ST, SV, SY, TJ, TM, TN, TR, TT, TZ, UA, UG, US, UZ, VC, VN, ZA, ZM, ZW.
- (84) Designated States (unless otherwise indicated, for every kind of regional protection available): ARIPO (BW, GH, GM, KE, LS, MW, MZ, NA, SD, SL, SZ, TZ, UG, ZM, ZW), Eurasian (AM, AZ, BY, KG, KZ, MD, RU, TJ, TM), European (AT, BE, BG, CH, CY, CZ, DE, DK, EE, ES, FI, FR, GB, GR, HR, HU, IE, IS, IT, LT, LU, LV, MC, MK, MT, NL, NO, PL, PT, RO, SE, SI, SK, TR), OAPI (BF, BJ, CF, CG, CI, CM, GA, GN, GQ, GW, ML, MR, NE, SN, TD, TG).

Published:
— with international search report

[Continued on next page]

(54) Title: METHODS AND ORGANISMS FOR UTILIZING SYNTHESIS GAS OR OTHER GASEOUS CARBON SOURCES AND METHANOL

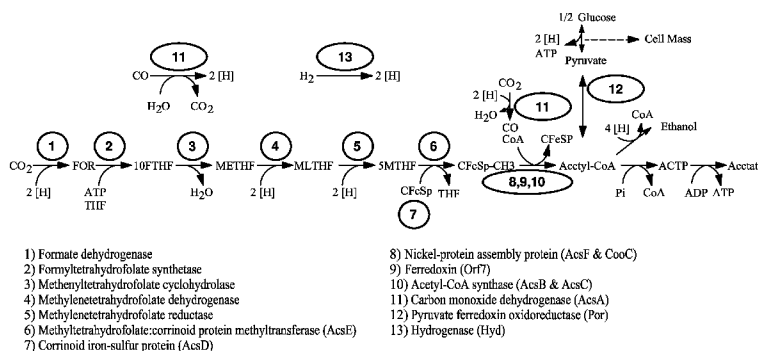

FIG. 6

(57) Abstract: The invention provides a non-naturally occurring microbial organism having an acetyl- CoA pathway and the capability of utilizing syngas or syngas and methanol. In one embodiment, the invention provides a non-naturally occurring microorganism, comprising one or more exogenous proteins conferring to the microorganism a pathway to convert CO, CO₂ and/or H₂ to acetyl-coenzyme A (acetyl-CoA), methyl tetrahydro folate (methyl-THF) or other desired products, wherein the microorganism lacks the ability to convert CO or CO₂ and H₂ to acetyl- CoA or methyl-THF in the absence of the one or more exogenous proteins. For example, the microbial organism can contain at least one exogenous nucleic acid encoding an enzyme or protein in an acetyl-CoA pathway. The microbial organism is capable of utilizing synthesis gases comprising CO, CO₂ and/or H₂, alone or in combination with methanol, to produce acetyl- CoA. The invention additionally provides a method for producing acetyl-CoA, for example, by culturing an acetyl-CoA producing microbial organism, where the microbial organism expresses at least one exogenous nucleic acid encoding an acetyl-CoA pathway enzyme or protein in a sufficient amount to produce acetyl-CoA, under conditions and for a sufficient period of time to produce acetyl-CoA.

WO 2009/094485 A1



-
- *before the expiration of the time limit for amending the claims and to be republished in the event of receipt of amendments*

METHODS AND ORGANISMS FOR UTILIZING SYNTHESIS GAS OR OTHER GASEOUS CARBON SOURCES AND METHANOL

BACKGROUND OF THE INVENTION

This application claims the benefit of priority of U.S. Provisional serial No. 61/022,804, filed
5 January 22, 2008, and U.S. Provisional serial No. 61/059,256, filed June 5, 2008, each of which
the entire contents are incorporated herein by reference.

The present invention relates generally to biosynthetic processes and more specifically to
organisms capable of using synthesis gas or other gaseous carbon sources and methanol.

Synthesis gas (syngas) is a mixture of primarily H₂ and CO that can be obtained via gasification
10 of any organic feedstock, such as coal, coal oil, natural gas, biomass, or waste organic matter.
Numerous gasification processes have been developed, and most designs are based on partial
oxidation, where limiting oxygen avoids full combustion, of organic materials at high
temperatures (500-1500°C) to provide syngas as a 0.5:1-3:1 H₂/CO mixture. Steam is sometimes
added to increase the hydrogen content, typically with increased CO₂ production through the
15 water gas shift reaction.

Today, coal is the main substrate used for industrial production of syngas, which is traditionally
used for heating and power and as a feedstock for Fischer-Tropsch synthesis of methanol and
liquid hydrocarbons. Many large chemical and energy companies employ coal gasification
processes on large scale and there is experience in the industry using this technology.

20 In addition to coal, many types of biomass have been used for syngas production. Gaseous
substrates such as syngas and CO₂ represent the most inexpensive and most flexible feedstocks
available for the biological production of renewable chemicals and fuels. During World War II,
there were over 1 million small scale biomass gasification units in operation, mainly in Europe,
for running cars, trucks, boats, and buses. Currently, there are at least three major biomass
25 gasification technologies that have been or are in the process of being validated on a commercial
scale (>20 million lb biomass/yr). Biomass gasification technologies are being practiced
commercially, particularly for heat and energy generation. Integration with fuels or chemicals
production is being developed and has not yet been demonstrated widely at a commercial scale.

Overall, technology now exists for cost-effective production of syngas from a plethora of
30 materials, including coal, biomass, wastes, polymers, and the like, at virtually any location in the
world. The benefits of using syngas include flexibility, since syngas can be produced from most

organic substances, including biomass. Another benefit is that syngas is inexpensive, costing \leq \$6 per million Btu, representing raw material costs of \leq \$0.10/lb product. In addition, there are known pathways, as in organisms such as *Clostridium* spp., that utilize syngas effectively.

5 Despite the availability of organisms that utilize syngas, in general the known organisms are poorly characterized and are not well suited for commercial development. For example, *Clostridium* and related bacteria are strict anaerobes that are intolerant to high concentrations of certain products such as butanol, thus limiting titers and commercialization potential. The *Clostridia* also produce multiple products, which presents separations issues in obtaining a desired product. Finally development of facile genetic tools to manipulate *Clostridial* genes is in
10 its infancy; therefore, they are not readily amenable to genetic engineering to improve yield or production characteristics of a desired product.

Thus, there exists a need to develop microorganisms and methods of their use to utilize syngas or other gaseous carbon sources for the production of desired chemicals and fuels. More specifically, there exists a need to develop microorganisms for synthesis gas utilization that also
15 have existing and efficient genetic tools to enable their rapid engineering to produce valuable products at useful rates and quantities. The present invention satisfies this need and provides related advantages as well.

SUMMARY OF INVENTION

The invention provides a non-naturally occurring microbial organism having an acetyl-CoA
20 pathway and the capability of utilizing syngas or syngas and methanol. In one embodiment, the invention provides a non-naturally occurring microorganism, comprising one or more exogenous proteins conferring to the microorganism a pathway to convert CO, CO₂ and/or H₂ to acetyl-coenzyme A (acetyl-CoA), methyl tetrahydrofolate (methyl-THF) or other desired products, wherein the microorganism lacks the ability to convert CO or CO₂ and H₂ to acetyl-CoA or
25 methyl-THF in the absence of the one or more exogenous proteins. For example, the microbial organism can contain at least one exogenous nucleic acid encoding an enzyme or protein in an acetyl-CoA pathway. The microbial organism is capable of utilizing synthesis gases comprising CO, CO₂ and/or H₂, alone or in combination with methanol, to produce acetyl-CoA. The invention additionally provides a method for producing acetyl-CoA, for example, by culturing an
30 acetyl-CoA producing microbial organism, where the microbial organism expresses at least one exogenous nucleic acid encoding an acetyl-CoA pathway enzyme or protein in a sufficient

amount to produce acetyl-CoA, under conditions and for a sufficient period of time to produce acetyl-CoA.

BRIEF DESCRIPTION OF THE DRAWINGS

Figure 1 shows an exemplary Wood-Ljungdahl pathway utilizing syngas as a carbon source. A methyl branch is depicted showing utilization of syngas to produce methyl-tetrahydrofolate (Me-THF).

Figure 2 shows an exemplary Wood-Ljungdahl pathway using syngas as a carbon source. A carbonyl branch is depicted showing utilization of syngas to produce acetyl-coenzyme A (acetyl-CoA). Hydrogenase (12) is required to convert hydrogen from syngas into reducing equivalents that are needed in many of the reactions depicted.

Figure 3 shows a metabolic pathway diagram depicting the integration of the Wood-Ljungdahl and butanol production pathways. The transformations that are typically unique to organisms capable of growth on synthesis gas are: 1) CO dehydrogenase, 2) hydrogenase, 3) energy-conserving hydrogenase (ECH), and 4) bi-functional CO dehydrogenase/acetyl-CoA synthase.

Figure 4 shows a diagram depicting a process for utilizing syngas to produce butanol. Figure 4A shows a block flow diagram for a syngas to butanol process. Figure 4B shows details of the gasifier. ASU represents air separation unit.

Figure 5 shows a proposed polyhydroxybutyrate (PHB) pathway modification in *R. rubrum* to form 1-butanol. Bold arrows indicate reaction steps that are introduced via heterologous expression of a 4-gene operon forming the 1-butanol pathway from *C. acetobutylicum*. Abbreviations used are PHB, poly- β -hydroxybutyrate; PhbC, PHB synthase; Crt, crotonase; Bcd, butyryl-CoA dehydrogenase; Etf, electron transfer flavoprotein; AdhE2, aldehyde/alcohol dehydrogenase.

Figure 6 shows a complete Wood-Ljungdahl pathway that allows the conversion of gases comprising CO, CO₂, and/or H₂ to acetyl-CoA, which can subsequently be converted to cell mass and products such as ethanol or acetate. Exemplary specific enzymatic transformations that can be engineered into a production host are numbered. Abbreviations: 10FTHF: 10-formyltetrahydrofolate, 5MTHF: 5-methyltetrahydrofolate, ACP: acetyl phosphate, FOR: formate, METHF: methylene-tetrahydrofolate, MLTHF: methenyl-tetrahydrofolate, THF: tetrahydrofolate.

Figure 7 shows a synthetic metabolic pathway that allows the conversion of gases comprising CO, CO₂, and/or H₂ and methanol to acetyl-CoA. The specific enzymatic transformations that can be engineered into a production host are numbered. Additional abbreviation: MeOH: methanol.

- 5 Figure 8 shows a pathway for conversion of methanol, CO and CO₂ to cell mass and fermentation products.

Figure 9 shows Western blots of 10 micrograms ACS90 (lane 1), ACS91 (lane2), Mta98/99 (lanes 3 and 4) cell extracts with size standards (lane 5) and controls of *M. thermoacetica* CODH (Moth_1202/1203) or Mtr (Moth_1197) proteins (50, 150, 250, 350, 450, 500, 750, 900, and
10 1000 ng).

Figure 10 shows CO oxidation assay results. Cells (*M. thermoacetica* or *E. coli* with the CODH/ACS operon; ACS90 or ACS91 or empty vector: pZA33S) were grown and extracts prepared. Assays were performed at 55°C at various times on the day the extracts were prepared. Reduction of methylviologen was followed at 578 nm over a 120 sec time course.

- 15 Figure 11 shows a synthetic metabolic pathway for the conversion of gases including CO, CO₂, and/or H₂, and methanol to acetyl-CoA and further to 4-hydroxybutyrate.

Figure 12 shows a synthetic metabolic pathway for the conversion of gases including CO, CO₂, and/or H₂, and methanol to acetyl-CoA and further to 1,4-butanediol.

- Figure 13 shows a synthetic metabolic pathway for the conversion of gases including CO, CO₂,
20 and/or H₂ to acetyl-CoA, and further to 4-hydroxybutyrate.

Figure 14 shows a synthetic metabolic pathway for the conversion of gases including CO, CO₂, and/or H₂ to acetyl-CoA, and further to 1,4-butanediol.

DETAILED DESCRIPTION OF THE INVENTION

- The present invention relates to developing and using microorganisms capable of utilizing
25 syngas or other gaseous carbon sources to produce a desired product. The invention further relates to expanding the product range of syngas-utilizing microorganisms and generating recombinant organisms capable of utilizing syngas to produce a desired product and optimizing their yields, titers, and productivities. Development of a recombinant organism, for example, *Escherichia coli* or other organisms suitable for commercial scale up, that can efficiently utilize

syngas as a substrate for growth and for chemical production provides cost-advantaged processes for renewable chemical and fuel manufacturing. The organisms can be optimized and tested rapidly and at reasonable costs.

The great potential of syngas as a feedstock resides in its ability to be efficiently and cost-effectively converted into chemicals and fuels of interest. Two main technologies for syngas conversion are Fischer-Tropsch processes and fermentative processes. The Fischer-Tropsch (F-T) technology has been developed since World War II and involves inorganic and metal-based catalysts that allow efficient production of methanol or mixed hydrocarbons as fuels. The drawbacks of F-T processes are: 1) a lack of product selectivity, which results in difficulties separating desired products; 2) catalyst sensitivity to poisoning; 3) high energy costs due to high temperatures and pressures required; and 4) the limited range of products available at commercially competitive costs.

For fermentative processes, syngas has been shown to serve as a carbon and energy source for many anaerobic microorganisms that can convert this material into products such as ethanol, acetate and hydrogen (see below and Table 1). The main benefits of fermentative conversion of syngas are the selectivity of organisms for production of single products, greater tolerance to syngas impurities, lower operating temperatures and pressures, and potential for a large portfolio of products from syngas. The main drawbacks of fermentative processes are that organisms known to convert syngas tend to generate only a limited range of chemicals, such as ethanol and acetate, and are not efficient producers of other chemicals, the organisms lack established tools for genetic manipulation, and the organisms are sensitive to end products at high concentrations.

The present invention relates to the generation of microorganisms that are effective at producing desired products, including chemicals and fuels, from syngas or other gaseous carbon sources. The organisms and methods of the present invention allow production of chemicals and fuels at costs that are significantly advantaged over both traditional petroleum-based products and products derived directly from glucose, sucrose or lignocellulosic sugars. In one embodiment, the invention provides a non-naturally occurring microorganism capable of utilizing syngas or other gaseous carbon sources to produce desired products in which the parent microorganism lacks the natural ability to utilize syngas (see Example VIII). In such microorganisms, one or more proteins or enzymes are expressed in the microorganism, thereby conferring a pathway to utilize syngas or other gaseous carbon source to produce a desired product. In other embodiments, the invention provides a non-naturally occurring microorganism that has been genetically modified, for example, by expressing one or more exogenous proteins or enzymes

that confer an increased efficiency of production of a desired product, where the parent microorganism has the ability to utilize syngas or other gaseous carbon source to produce a desired product. Thus, the invention relates to generating a microorganism with a new metabolic pathway capable of utilizing syngas as well as generating a microorganism with improved efficiency of utilizing syngas or other gaseous carbon source to produce a desired product.

The present invention additionally provides a non-naturally occurring microorganism expressing genes encoding enzymes that catalyze and proteins associated with the carbonyl-branch of the Wood-Ljungdahl pathway in conjunction with a MtaABC-type methyltransferase system. Such an organism is capable of converting methanol, a relatively inexpensive organic feedstock that can be derived from synthesis gas, and gases comprising CO, CO₂, and/or H₂ into acetyl-CoA, cell mass, and products.

Escherichia coli is an industrial workhorse organism with an unrivaled suite of genetic tools. Engineering the capability to convert synthesis gas into acetyl-CoA, the central metabolite from which all cell mass components and many valuable products can be derived, into a foreign host such as *E. coli* can be accomplished following the expression of exogenous genes that encode various proteins of the Wood-Ljungdahl pathway. This pathway is highly active in acetogenic organisms such as *Moorella thermoacetica* (formerly, *Clostridium thermoaceticum*), which has been the model organism for elucidating the Wood-Ljungdahl pathway since its isolation in 1942 (Fontaine et al., *J Bacteriol.* 43:701-715 (1942)). The Wood-Ljungdahl pathway comprises two branches: the Eastern, or methyl, branch that allows the conversion of CO₂ to methyltetrahydrofolate (Me-THF) and the Western, or carbonyl, branch that allows the conversion of methyl-THF, CO, and Coenzyme-A into acetyl-CoA (see Figures 1 and 2). As disclosed herein, the invention provides a non-naturally occurring microorganism expressing genes that catalyze both branches of the Wood-Ljungdahl pathway. Such an organism is capable of converting gasses comprising CO, CO₂, and/or H₂ into acetyl-CoA, cell mass, and products. The invention additionally provides a non-naturally occurring microorganism expressing genes encoding enzymes that catalyze the carbonyl-branch of the Wood-Ljungdahl pathway in conjunction with a MtaABC-type methyltransferase system. Such an organism is capable of converting methanol, a relatively inexpensive organic feedstock that can be derived from synthesis gas, and gases comprising CO, CO₂, and/or H₂ into acetyl-CoA, cell mass, and products.

Synthesis gas, also known as syngas or producer gas, is the major product of gasification of coal and of carbonaceous materials such as biomass materials, including agricultural crops and residues. Syngas is a mixture primarily of H₂ and CO and can be obtained from the gasification of any organic feedstock, including but not limited to coal, coal oil, natural gas, biomass, and waste organic matter. Gasification is generally carried out under a high fuel to oxygen ratio. Although largely H₂ and CO, syngas can also include CO₂ and other gases in smaller quantities. Thus, synthesis gas provides a cost effective source of gaseous carbon such as CO and, additionally, CO₂.

As disclosed herein, gaseous carbon sources such as syngas comprising CO and/or CO₂ can be utilized by non-naturally occurring microorganisms of the invention to produce a desired product. Although generally exemplified herein as syngas, it is understood that any source of gaseous carbon comprising CO and/or CO₂ can be utilized by the non-naturally occurring microorganisms of the invention. Thus, the invention relates to non-naturally occurring microorganisms that are capable of utilizing CO and/or CO₂ as a carbon source.

The Wood-Ljungdahl pathway catalyzes the conversion of CO and H₂ to acetyl-CoA and other products such as acetate. Organisms capable of utilizing CO and syngas also generally have the capability of utilizing CO₂ and CO₂/H₂ mixtures through the same basic set of enzymes and transformations encompassed by the Wood-Ljungdahl pathway. H₂-dependent conversion of CO₂ to acetate by microorganisms was recognized long before it was revealed that CO also could be used by the same organisms and that the same pathways were involved. Many acetogens have been shown to grow in the presence of CO₂ and produce compounds such as acetate as long as hydrogen is present to supply the necessary reducing equivalents (see for example, Drake, *Acetogenesis*, pp. 3-60 Chapman and Hall, New York, (1994)). This can be summarized by the following equation:



Hence, non-naturally occurring microorganisms possessing the Wood-Ljungdahl pathway can utilize CO₂ and H₂ mixtures as well for the production of acetyl-CoA and other desired products.

The Wood-Ljungdahl pathway is well known in the art and consists of 12 reactions which can be separated into two branches: (1) methyl branch and (2) carbonyl branch. The methyl branch converts syngas to methyl-tetrahydrofolate (methyl-THF) whereas the carbonyl branch converts methyl-THF to acetyl-CoA. The reactions in the methyl branch are catalyzed in order by the following enzymes or proteins: ferredoxin oxidoreductase, formate dehydrogenase,

formyltetrahydrofolate synthetase, methenyltetrahydrofolate cyclodehydratase, methylenetetrahydrofolate dehydrogenase and methylenetetrahydrofolate reductase. The reactions in the carbonyl branch are catalyzed in order by the following enzymes or proteins: methyltetrahydrofolate:corrinoid protein methyltransferase (for example, AcsE), corrinoid iron-sulfur protein, nickel-protein assembly protein (for example, AcsF), ferredoxin, acetyl-CoA synthase, carbon monoxide dehydrogenase and nickel-protein assembly protein (for example, CooC). Following the teachings and guidance provided herein for introducing a sufficient number of encoding nucleic acids to generate a acetyl-CoA pathway, those skilled in the art will understand that the same engineering design also can be performed with respect to introducing at least the nucleic acids encoding the Wood-Ljungdahl enzymes or proteins absent in the host organism. Therefore, introduction of one or more encoding nucleic acids into the microbial organisms of the invention such that the modified organism contains one branch or the complete Wood-Ljungdahl pathway will confer syngas utilization ability.

Thus, the non-naturally occurring microorganisms of the invention can use syngas or other gaseous carbon sources providing CO and/or CO₂ to produce a desired product. In the case of CO₂, additional sources include, but are not limited to, production of CO₂ as a byproduct in ammonia and hydrogen plants, where methane is converted to CO₂; combustion of wood and fossil fuels; production of CO₂ as a byproduct of fermentation of sugar in the brewing of beer, whisky and other alcoholic beverages, or other fermentative processes; thermal decomposition of limestone, CaCO₃, in the manufacture of lime, CaO; production of CO₂ as byproduct of sodium phosphate manufacture; and directly from natural carbon dioxide springs, where it is produced by the action of acidified water on limestone or dolomite.

As used herein, the term “non-naturally occurring” when used in reference to a microbial organism or microorganism of the invention is intended to mean that the microbial organism has at least one genetic alteration not normally found in a naturally occurring strain of the referenced species, including wild-type strains of the referenced species. Genetic alterations include, for example, modifications introducing expressible nucleic acids encoding metabolic polypeptides, other nucleic acid additions, nucleic acid deletions and/or other functional disruption of the microbial genetic material. Such modifications include, for example, coding regions and functional fragments thereof, for heterologous, homologous or both heterologous and homologous polypeptides for the referenced species. Additional modifications include, for example, non-coding regulatory regions in which the modifications alter expression of a gene or

operon. Exemplary metabolic polypeptides include enzymes or proteins within an acetyl-CoA biosynthetic pathway.

A metabolic modification refers to a biochemical reaction that is altered from its naturally occurring state. Therefore, non-naturally occurring microorganisms can have genetic
5 modifications to nucleic acids encoding metabolic polypeptides or, functional fragments thereof. Exemplary metabolic modifications are disclosed herein.

As used herein, the term “isolated” when used in reference to a microbial organism or microorganism is intended to mean an organism that is substantially free of at least one component as the referenced microbial organism is found in nature. The term includes a
10 microbial organism that is removed from some or all components as it is found in its natural environment. The term also includes a microbial organism that is removed from some or all components as the microbial organism is found in non-naturally occurring environments. Therefore, an isolated microbial organism is partly or completely separated from other
15 substances as it is found in nature or as it is grown, stored or subsisted in non-naturally occurring environments. Specific examples of isolated microbial organisms include partially pure microbes, substantially pure microbes and microbes cultured in a medium that is non-naturally occurring.

As used herein, the terms “microbial,” “microbial organism” or “microorganism” is intended to mean any organism that exists as a microscopic cell that is included within the domains of
20 archaea, bacteria or eukarya. Therefore, the term is intended to encompass prokaryotic or eukaryotic cells or organisms having a microscopic size and includes bacteria, archaea and eubacteria of all species as well as eukaryotic microorganisms such as yeast and fungi. The term also includes cell cultures of any species that can be cultured for the production of a biochemical.

As used herein, the term “CoA” or “coenzyme A” is intended to mean an organic cofactor or
25 prosthetic group (nonprotein portion of an enzyme) whose presence is required for the activity of many enzymes (the apoenzyme) to form an active enzyme system. Coenzyme A functions in certain condensing enzymes, acts in acetyl or other acyl group transfer and in fatty acid synthesis and oxidation, pyruvate oxidation and in other acetylation.

As used herein, the term “substantially anaerobic” when used in reference to a culture or growth
30 condition is intended to mean that the amount of oxygen is less than about 10% of saturation for dissolved oxygen in liquid media. The term also is intended to include sealed chambers of liquid or solid medium maintained with an atmosphere of less than about 1% oxygen.

“Exogenous” as it is used herein is intended to mean that the referenced molecule or the referenced activity is introduced into the host microbial organism. The molecule can be introduced, for example, by introduction of an encoding nucleic acid into the host genetic material such as by integration into a host chromosome or as non-chromosomal genetic material such as a plasmid. Therefore, the term as it is used in reference to expression of an encoding nucleic acid refers to introduction of the encoding nucleic acid in an expressible form into the microbial organism. When used in reference to a biosynthetic activity, the term refers to an activity that is introduced into the host reference organism. The source can be, for example, a homologous or heterologous encoding nucleic acid that expresses the referenced activity following introduction into the host microbial organism. Therefore, the term “endogenous” refers to a referenced molecule or activity that is present in the host. Similarly, the term when used in reference to expression of an encoding nucleic acid refers to expression of an encoding nucleic acid contained within the microbial organism. The term “heterologous” refers to a molecule or activity derived from a source other than the referenced species whereas “homologous” refers to a molecule or activity derived from the host microbial organism. Accordingly, exogenous expression of an encoding nucleic acid of the invention can utilize either or both a heterologous or homologous encoding nucleic acid.

The non-naturally occurring microbial organisms of the invention can contain stable genetic alterations, which refers to microorganisms that can be cultured for greater than five generations without loss of the alteration. Generally, stable genetic alterations include modifications that persist greater than 10 generations, particularly stable modifications will persist more than about 25 generations, and more particularly, stable genetic modifications will be greater than 50 generations, including indefinitely.

Those skilled in the art will understand that the genetic alterations, including metabolic modifications exemplified herein, are described with reference to a suitable host organism such as *E. coli* and their corresponding metabolic reactions or a suitable source organism for desired genetic material such as genes for a desired metabolic pathway. However, given the complete genome sequencing of a wide variety of organisms and the high level of skill in the area of genomics, those skilled in the art will readily be able to apply the teachings and guidance provided herein to essentially all other organisms. For example, the *E. coli* metabolic alterations exemplified herein can readily be applied to other species by incorporating the same or analogous encoding nucleic acid from species other than the referenced species. Such genetic

alterations include, for example, genetic alterations of species homologs, in general, and in particular, orthologs, paralogs or nonorthologous gene displacements.

An ortholog is a gene or genes that are related by vertical descent and are responsible for substantially the same or identical functions in different organisms. For example, mouse epoxide
5 hydrolyase and human epoxide hydrolyase can be considered orthologs for the biological function of hydrolysis of epoxides. Genes are related by vertical descent when, for example, they share sequence similarity of sufficient amount to indicate they are homologous, or related by evolution from a common ancestor. Genes can also be considered orthologs if they share three-
10 dimensional structure but not necessarily sequence similarity, of a sufficient amount to indicate that they have evolved from a common ancestor to the extent that the primary sequence similarity is not identifiable. Genes that are orthologous can encode proteins with sequence similarity of about 25% to 100% amino acid sequence identity. Genes encoding proteins sharing an amino acid similarity less than 25% can also be considered to have arisen by vertical descent if their three-dimensional structure also shows similarities. Members of the serine protease family
15 of enzymes, including tissue plasminogen activator and elastase, are considered to have arisen by vertical descent from a common ancestor.

Orthologs include genes or their encoded gene products that through, for example, evolution, have diverged in structure or overall activity. For example, where one species encodes a gene product exhibiting two functions and where such functions have been separated into distinct
20 genes in a second species, the three genes and their corresponding products are considered to be orthologs. For the production of a biochemical product, those skilled in the art will understand that the orthologous gene harboring the metabolic activity to be introduced or disrupted is to be chosen for construction of the non-naturally occurring microorganism. An example of orthologs exhibiting separable activities is where distinct activities have been separated into distinct gene
25 products between two or more species or within a single species. A specific example is the separation of elastase proteolysis and plasminogen proteolysis, two types of serine protease activity, into distinct molecules as plasminogen activator and elastase. A second example is the separation of mycoplasma 5'-3' exonuclease and *Drosophila* DNA polymerase III activity. The DNA polymerase from the first species can be considered an ortholog to either or both of the
30 exonuclease or the polymerase from the second species and vice versa.

In contrast, paralogs are homologs related by, for example, duplication followed by evolutionary divergence and have similar or common, but not identical functions. Paralogs can originate or derive from, for example, the same species or from a different species. For example, microsomal

epoxide hydrolase (epoxide hydrolase I) and soluble epoxide hydrolase (epoxide hydrolase II) can be considered paralogs because they represent two distinct enzymes, co-evolved from a common ancestor, that catalyze distinct reactions and have distinct functions in the same species. Paralogs are proteins from the same species with significant sequence similarity to each other
5 suggesting that they are homologous, or related through co-evolution from a common ancestor. Groups of paralogous protein families include HipA homologs, luciferase genes, peptidases, and others.

A nonorthologous gene displacement is a nonorthologous gene from one species that can substitute for a referenced gene function in a different species. Substitution includes, for
10 example, being able to perform substantially the same or a similar function in the species of origin compared to the referenced function in the different species. Although generally, a nonorthologous gene displacement will be identifiable as structurally related to a known gene encoding the referenced function, less structurally related but functionally similar genes and their corresponding gene products nevertheless will still fall within the meaning of the term as it is
15 used herein. Functional similarity requires, for example, at least some structural similarity in the active site or binding region of a nonorthologous gene product compared to a gene encoding the function sought to be substituted. Therefore, a nonorthologous gene includes, for example, a paralog or an unrelated gene.

Therefore, in identifying and constructing the non-naturally occurring microbial organisms of the
20 invention having acetyl-CoA biosynthetic capability, those skilled in the art will understand with applying the teaching and guidance provided herein to a particular species that the identification of metabolic modifications can include identification and inclusion or inactivation of orthologs. To the extent that paralogs and/or nonorthologous gene displacements are present in the referenced microorganism that encode an enzyme catalyzing a similar or substantially similar
25 metabolic reaction, those skilled in the art also can utilize these evolutionally related genes.

Orthologs, paralogs and nonorthologous gene displacements can be determined by methods well known to those skilled in the art. For example, inspection of nucleic acid or amino acid sequences for two polypeptides will reveal sequence identity and similarities between the compared sequences. Based on such similarities, one skilled in the art can determine if the
30 similarity is sufficiently high to indicate the proteins are related through evolution from a common ancestor. Algorithms well known to those skilled in the art, such as Align, BLAST, Clustal W and others compare and determine a raw sequence similarity or identity, and also determine the presence or significance of gaps in the sequence which can be assigned a weight or

score. Such algorithms also are known in the art and are similarly applicable for determining nucleotide sequence similarity or identity. Parameters for sufficient similarity to determine relatedness are computed based on well known methods for calculating statistical similarity, or the chance of finding a similar match in a random polypeptide, and the significance of the match determined. A computer comparison of two or more sequences can, if desired, also be optimized visually by those skilled in the art. Related gene products or proteins can be expected to have a high similarity, for example, 25% to 100% sequence identity. Proteins that are unrelated can have an identity which is essentially the same as would be expected to occur by chance, if a database of sufficient size is scanned (about 5%). Sequences between 5% and 24% may or may not represent sufficient homology to conclude that the compared sequences are related. Additional statistical analysis to determine the significance of such matches given the size of the data set can be carried out to determine the relevance of these sequences.

Exemplary parameters for determining relatedness of two or more sequences using the BLAST algorithm, for example, can be as set forth below. Briefly, amino acid sequence alignments can be performed using BLASTP version 2.0.8 (Jan-05-1999) and the following parameters: Matrix: 0 BLOSUM62; gap open: 11; gap extension: 1; x_dropoff: 50; expect: 10.0; wordsize: 3; filter: on. Nucleic acid sequence alignments can be performed using BLASTN version 2.0.6 (Sept-16-1998) and the following parameters: Match: 1; mismatch: -2; gap open: 5; gap extension: 2; x_dropoff: 50; expect: 10.0; wordsize: 11; filter: off. Those skilled in the art will know what modifications can be made to the above parameters to either increase or decrease the stringency of the comparison, for example, and determine the relatedness of two or more sequences.

In one embodiment, the invention provides a non-naturally occurring microorganism comprising one or more exogenous proteins conferring to the microorganism a pathway to convert CO and/or CO₂ and H₂ to acetyl-coenzyme A (acetyl-CoA), wherein the microorganism lacks the ability to convert CO and/or CO₂ and H₂ to acetyl-CoA in the absence of the one or more exogenous proteins. For example, the one or more exogenous proteins or enzymes can be selected from cobalamide corrinoid/iron-sulfur protein, methyltransferase, carbon monoxide dehydrogenase, acetyl-CoA synthase, acetyl-CoA synthase disulfide reductase and hydrogenase (see Figure 1 and Examples VII and VIII). The microorganism can also express two or more, three or more, and the like, including up to all the proteins and enzymes that confer a pathway to convert CO and/or CO₂ and H₂ to acetyl-CoA, for example, cobalamide corrinoid/iron-sulfur protein, methyltransferase, carbon monoxide dehydrogenase, acetyl-CoA synthase, acetyl-CoA synthase disulfide reductase and hydrogenase.

As disclosed herein, an embodiment of the invention relates to generating a non-naturally occurring microorganism that can utilize CO and/or CO₂ as a carbon source to produce a desired product. For example, the proteins and enzymes of the carbonyl and/or methyl branch of the Wood-Ljungdahl pathway (Figures 1 and 2) are introduced into a microorganism that does not naturally contain the Wood-Ljungdahl enzymes. A particularly useful organism for genetically engineering a Wood-Ljungdahl pathway is *E. coli*, which is well characterized in terms of available genetic manipulation tools as well as fermentation conditions (see Example VIII).

In another embodiment, the invention provides a non-naturally occurring microorganism comprising one or more exogenous proteins conferring to the microorganism a pathway to convert synthesis gas, also known as syngas, or other gaseous carbon source, comprising CO and H₂ to acetyl-coenzyme A (acetyl-CoA), wherein the microorganism lacks the ability to convert CO and H₂ to acetyl-CoA in the absence of the one or more exogenous proteins. Such a synthesis gas or other gas can further comprise CO₂. Thus, a non-naturally occurring microorganism of the invention can comprise a pathway that increases the efficiency of converting CO₂, CO and/or H₂ to acetyl-CoA. In addition, the invention provides a non-naturally occurring microorganism comprising one or more exogenous proteins conferring to the microorganism a pathway to convert a gaseous carbon source comprising CO₂ and H₂ to acetyl-CoA, wherein the microorganism lacks the ability to convert CO₂ and H₂ to acetyl-CoA in the absence of the one or more exogenous proteins. The gas can further comprise CO. As discussed herein, the exogenous proteins can be selected from cobalamide corrinoid/iron-sulfur protein, methyltransferase, carbon monoxide dehydrogenase, acetyl-CoA synthase, acetyl-CoA synthase disulfide reductase and hydrogenase.

In yet another embodiment, the invention provides a non-naturally occurring microorganism comprising one or more exogenous proteins conferring to the microorganism a pathway to convert CO and/or CO₂ and H₂ to methyl-tetrahydrofolate (methyl-THF), wherein the microorganism lacks the ability to convert CO and/or CO₂ and H₂ to methyl-THF in the absence of the one or more exogenous proteins. As disclosed herein, the one or more exogenous proteins can be selected from ferredoxin oxidoreductase, formate dehydrogenase, formyltetrahydrofolate synthetase, methenyltetrahydrofolate cyclodehydratase, methylenetetrahydrofolate dehydrogenase and methylenetetrahydrofolate reductase (see Figure 1 and Example VIII). The microorganism can also express two or more, three or more, and the like, including up to all the proteins and enzymes that confer a pathway to convert CO and/or CO₂ and H₂ to methyl-THF, including up to all of ferredoxin oxidoreductase, formate dehydrogenase, formyltetrahydrofolate

synthetase, methenyltetrahydrofolate cyclodehydratase, methylenetetrahydrofolate dehydrogenase and methylenetetrahydrofolate reductase.

The invention additionally provides a non-naturally occurring microorganism comprising one or more exogenous proteins conferring to the microorganism a pathway to convert synthesis gas or
5 other gaseous carbon source comprising CO and H₂ to methyl-THF, wherein the microorganism lacks the ability to convert CO and H₂ to methyl-THF in the absence of the one or more exogenous proteins. The synthesis gas can further comprise CO₂. In addition, the invention provides a non-naturally occurring microorganism comprising one or more exogenous proteins conferring to the microorganism a pathway to convert a gaseous carbon source comprising CO₂
10 and H₂ to methyl-THF, wherein the microorganism lacks the ability to convert CO₂ and H₂ to methyl-THF in the absence of the one or more exogenous proteins. The gaseous carbon source can further comprise CO. As discussed above, the exogenous proteins can be selected from ferredoxin oxidoreductase, formate dehydrogenase, formyltetrahydrofolate synthetase, methenyltetrahydrofolate cyclodehydratase, methylenetetrahydrofolate dehydrogenase and
15 methylenetetrahydrofolate reductase.

Thus, the invention relates to non-naturally occurring microorganisms and methods of utilizing such microorganisms to produce a desired product such as acetyl-CoA or methyl-THF from a synthesis gas or other gas comprising CO and/or CO₂ and particularly generating
microorganisms capable of utilizing syngas or other other gas comprising CO and/or CO₂ that
20 were not previously capable of utilizing syngas or another gas comprising CO and/or CO₂ as a carbon source (see Example VIII). Further, a microorganism can be engineered to contain both the methyl and carbonyl branches of the Wood-Ljungdahl pathway (Figures 1, 2 and 6). In addition, other desired products can also be produced by engineering the microorganisms to produce a desired product by expressing proteins or enzymes capable of producing a desired
25 product, for example, producing a product having acetyl-CoA or methyl-THF as a precursor (see Figure 3). As disclosed herein, such microorganisms can be generated by expressing proteins or genes that confer a desired metabolic pathway or by determining deletions that can drive metabolism towards a desired product.

In addition, the invention provides a non-naturally occurring microorganism comprising a
30 genetic modification conferring to the microorganism an increased efficiency of producing acetyl-CoA from CO and/or CO₂ and H₂ relative to the microorganism in the absence of the genetic modification, wherein the microorganism comprises a pathway to convert CO and/or CO₂ and H₂ to acetyl-CoA. In such a microorganism, the genetic modification can comprise

expression of one or more nucleic acid molecules encoding one or more exogenous proteins, whereby expression of the one or more exogenous proteins increases the efficiency of producing acetyl-CoA from CO and/or CO₂ and H₂. The one or more exogenous proteins can be selected from cobalamide corrinoid/iron-sulfur protein, methyltransferase, carbon monoxide

5 dehydrogenase, acetyl-CoA synthase, acetyl-CoA synthase disulfide reductase and hydrogenase, including up to all such proteins, as disclosed herein. Such a non-naturally occurring microorganism can alternatively or additionally have a genetic modification comprising one or more gene disruptions, whereby the one or more gene disruptions increases the efficiency of producing acetyl-CoA from CO and/or CO₂ and H₂. In addition, the invention provides a non-

10 naturally occurring microorganism comprising a genetic modification conferring an increased efficiency of producing methyl-THF or other desired products using the methods disclosed herein. Thus, the invention additionally relates to improving the efficiency of production of a desired product in a microorganism already having the ability to produce the desired product from syngas or other gases comprising CO and/or CO₂.

15 The invention also relates to a non-naturally occurring microorganism comprising one or more proteins conferring utilization of syngas or other gas comprising CO and/or CO₂ as a carbon source to the microorganism, wherein the microorganism lacks the ability to utilize the carbon source in the absence of the one or more proteins conferring utilization of CO and/or CO₂. Further, the invention provides a non-naturally occurring microorganism comprising one or more

20 proteins conferring utilization of carbon monoxide and/or carbon dioxide as a carbon source to the microorganism, wherein the microorganism lacks the ability to utilize the carbon source in the absence of the one or more proteins. In yet another embodiment, the invention provides a non-naturally occurring microorganism, comprising one or more proteins conferring utilization of CO and/or CO₂, in combination with H₂, as a carbon source to the microorganism, wherein the

25 microorganism lacks the ability to utilize the carbon source in the absence of the one or more proteins. The invention additionally provides a non-naturally occurring microorganism comprising one or more proteins conferring utilization of CO, in combination with H₂ and CO₂, as a carbon source to the microorganism, wherein the microorganism lacks the ability to utilize the carbon source in the absence of the one or more proteins. Such a microorganism can be used

30 to produce a desired product from the carbon source, for example, methyl-tetrahydrofolate or acetyl-coenzyme A (acetyl-CoA) or other desired products, as disclosed herein, including products synthesized from acetyl-CoA or methyl-THF. Such a non-naturally occurring microorganism can express one or more exogenous proteins that increase production of the product, as disclosed herein (see Figures 1 and 2).

The invention further provides a non-naturally occurring microorganism comprising one or more exogenous proteins conferring utilization of syngas or other gaseous carbon source to the microorganism, wherein the microorganism has the ability to utilize the carbon source in the absence of the one or more exogenous proteins, whereby expression of the one or more
5 exogenous proteins increases the efficiency of utilization of the carbon source. Additionally the invention provides a non-naturally occurring microorganism comprising one or more exogenous proteins conferring utilization of carbon monoxide as a carbon source to the microorganism, wherein the microorganism has the ability to utilize the carbon source in the absence of the one or more exogenous proteins, whereby expression of the one or more exogenous proteins
10 increases the efficiency of utilization of the carbon source.

In yet another embodiment, the invention provides a non-naturally occurring microorganism comprising one or more exogenous proteins conferring utilization of CO and/or CO₂, in combination with H₂, as a carbon source to the microorganism, wherein the microorganism has the ability to utilize the carbon source in the absence of the one or more exogenous proteins,
15 whereby expression of the one or more exogenous proteins increases the efficiency of utilization of the carbon source. Additionally provided is a non-naturally occurring microorganism comprising one or more exogenous proteins conferring utilization of CO, in combination with H₂ and CO₂, as a carbon source to the microorganism, wherein the microorganism has the ability to utilize the carbon source in the absence of the one or more exogenous proteins, whereby
20 expression of the one or more exogenous proteins increases the efficiency of utilization of the carbon source. Such a microorganism can be used to produce a desired product such as acetyl-CoA, methyl-THF or other desired products from the carbon source, as disclosed herein.

The invention also provides a non-naturally occurring microbial organism capable of producing acetyl-CoA utilizing methanol and syngas. Thus, the microbial organism is capable of utilizing
25 methanol and CO, CO₂ and/or H₂, for example, CO₂, CO₂ and H₂, CO, CO and H₂, CO₂ and CO, or CO₂, CO and H₂, to produce acetyl-CoA. Since acetyl-CoA is produced in most microbial organisms, it is understood that a non-naturally occurring microbial organism of the invention that is capable of producing acetyl-CoA is one that has been engineered to include a desired pathway. Furthermore, the microbial organism is engineered to utilize methanol and syngas to
30 produce acetyl-CoA (see Examples). In one embodiment, the invention provides a non-naturally occurring microbial organism having an acetyl-coenzyme A (acetyl-CoA) pathway comprising at least one exogenous nucleic acid encoding an acetyl-CoA pathway enzyme or protein expressed in a sufficient amount to produce acetyl-CoA, the acetyl-CoA pathway comprising methanol-

methyltransferase and acetyl-CoA synthase/carbon monoxide dehydrogenase. In such a non-naturally occurring microbial organism, the acetyl-CoA pathway can confer the ability to convert CO₂, CO and/or H₂, that is, a combination thereof, to acetyl Co-A. The methanol-methyltransferase activity of such an acetyl-CoA pathway can comprise, for example, an enzyme or protein selected from methanol methyltransferase, corrinoid protein (such as MtaC) and methyltetrahydrofolate:corrinoid protein methyltransferase (such as MtaA)(see Examples II and III). The acetyl-CoA synthase/carbon monoxide dehydrogenase activity of such an acetyl-CoA pathway can comprise, for example, an enzyme or protein selected from methyltetrahydrofolate:corrinoid protein methyltransferase (such as AcsE), corrinoid iron-sulfur protein (such as AcsD), nickel-protein assembly protein (such as AcsF), ferredoxin, acetyl-CoA synthase, carbon monoxide dehydrogenase and nickel-protein assembly protein (such as CooC)(see Examples II and III). As disclosed herein, two or more, three or more, four or more, five or more, six or more, seven or more, eight or more, nine or more, and so forth, nucleic acids encoding an acetyl-CoA pathway can be expressed in a non-naturally occurring microbial organism of the invention. In a particular embodiment, the non-naturally occurring microbial organism can comprise ten exogenous nucleic acids that encode a methanol-methyltransferase comprising methanol methyltransferase, corrinoid protein (such as MtaC) and methyltetrahydrofolate:corrinoid protein methyltransferase (such as MtaA) and an acetyl-CoA synthase/carbon monoxide dehydrogenase comprising methyltetrahydrofolate:corrinoid protein methyltransferase (such as AcsE), corrinoid iron-sulfur protein (such as AcsD), nickel-protein assembly protein (such as CooC), ferredoxin, acetyl-CoA synthase, carbon monoxide dehydrogenase and nickel-protein assembly protein (such as AcsF).

In yet another embodiment, the non-naturally occurring microbial organism can further comprise pyruvate ferredoxin oxidoreductase. For example, the pyruvate ferredoxin oxidoreductase can be encoded by an exogenous nucleic acid. In still another embodiment, the non-naturally occurring microbial organism can further comprise hydrogenase, which can be encoded by an endogenous or exogenous nucleic acid, as disclosed herein (see Examples II and III).

As disclosed herein, a non-naturally occurring microbial organism can contain, for example, at least one exogenous nucleic acid that is a heterologous nucleic acid. As further disclosed herein, the non-naturally occurring microbial organism can be grown, for example, in a substantially anaerobic culture medium.

The invention is described herein with general reference to the metabolic reaction, reactant or product thereof, or with specific reference to one or more nucleic acids or genes encoding an enzyme associated with or catalyzing, or a protein associated with, the referenced metabolic reaction, reactant or product. Unless otherwise expressly stated herein, those skilled in the art will understand that reference to a reaction also constitutes reference to the reactants and products of the reaction. Similarly, unless otherwise expressly stated herein, reference to a reactant or product also references the reaction, and reference to any of these metabolic constituents also references the gene or genes encoding the enzymes that catalyze or proteins involved in the referenced reaction, reactant or product. Likewise, given the well known fields of metabolic biochemistry, enzymology and genomics, reference herein to a gene or encoding nucleic acid also constitutes a reference to the corresponding encoded enzyme and the reaction it catalyzes or a protein associated with the reaction as well as the reactants and products of the reaction.

The non-naturally occurring microbial organisms of the invention can be produced by introducing expressible nucleic acids encoding one or more of the enzymes or proteins participating in one or more acetyl-CoA biosynthetic pathways. Depending on the host microbial organism chosen for biosynthesis, nucleic acids for some or all of a particular acetyl-CoA biosynthetic pathway can be expressed. For example, if a chosen host is deficient in one or more enzymes or proteins for a desired biosynthetic pathway, then expressible nucleic acids for the deficient enzyme(s) or protein(s) are introduced into the host for subsequent exogenous expression. Alternatively, if the chosen host exhibits endogenous expression of some pathway genes, but is deficient in others, then an encoding nucleic acid is needed for the deficient enzyme(s) or protein(s) to achieve acetyl-CoA biosynthesis. Thus, a non-naturally occurring microbial organism of the invention can be produced by introducing exogenous enzyme or protein activities to obtain a desired biosynthetic pathway or a desired biosynthetic pathway can be obtained by introducing one or more exogenous enzyme or protein activities that, together with one or more endogenous enzymes or proteins, produces a desired product such as acetyl-CoA.

Depending on the acetyl-CoA biosynthetic pathway constituents of a selected host microbial organism, the non-naturally occurring microbial organisms of the invention will include at least one exogenously expressed acetyl-CoA pathway-encoding nucleic acid and up to all encoding nucleic acids for one or more acetyl-CoA biosynthetic pathways. For example, acetyl-CoA biosynthesis can be established in a host deficient in a pathway enzyme or protein through

exogenous expression of the corresponding encoding nucleic acid. In a host deficient in all enzymes or proteins of a acetyl-CoA pathway, exogenous expression of all enzyme or proteins in the pathway can be included, although it is understood that all enzymes or proteins of a pathway can be expressed even if the host contains at least one of the pathway enzymes or proteins. For
5 example, exogenous expression of all enzymes or proteins in a pathway for production of acetyl-CoA can be included, such as the methanol-methyltransferase, which can include methanol methyltransferase, corrinoid protein (such as MtaC) and methyltetrahydrofolate:corrinoid protein methyltransferase (such as MtaA), and the acetyl-CoA synthase/carbon monoxide
10 dehydrogenase, which can include methyltetrahydrofolate:corrinoid protein methyltransferase (such as AcsE), corrinoid iron-sulfur protein (such as AcsD), nickel-protein assembly protein (such as AcsF), ferredoxin, acetyl-CoA synthase, carbon monoxide dehydrogenase and nickel-protein assembly protein (such as CooC).

In another embodiment, in a pathway for producing acetyl-CoA from syngas or other gaseous carbon source, one or more proteins in the biosynthetic pathway can be selected from
15 cobalamide corrinoid/iron-sulfur protein, methyltransferase, carbon monoxide dehydrogenase, acetyl-CoA synthase, acetyl-CoA synthase disulfide reductase and hydrogenase (see Figure 2 and Examples VII and VIII). In a pathway for producing methyl-THF, one or more proteins in the biosynthetic pathway can be selected from ferredoxin oxidoreductase, formate
20 dehydrogenase, formyltetrahydrofolate synthetase, methenyltetrahydrofolate cyclodehydratase, methylenetetrahydrofolate dehydrogenase and methylenetetrahydrofolate reductase (see Figure 1 and Example VIII). In addition, genes that encode the enzymes required to produce both acetyl-CoA and methyl-THF can be introduced into a microorganism (see Figure 3 and Example VIII). Metabolic pathways for production of additional desired products, including succinate, 4-
25 hydroxybutyrate and 1,4-butanediol are described, for example, in U.S. application serial No. 11/891,602, filed August 10, 2007, and WO/2008/115840 (see Example VIII).

Given the teachings and guidance provided herein, those skilled in the art will understand that the number of encoding nucleic acids to introduce in an expressible form will, at least, parallel the acetyl-CoA pathway deficiencies of the selected host microbial organism. Therefore, a non-naturally occurring microbial organism of the invention can have one, two, three, four, five, six,
30 seven, eight, nine or up to all nucleic acids encoding the enzymes or proteins constituting a acetyl-CoA biosynthetic pathway disclosed herein. In some embodiments, the non-naturally occurring microbial organisms also can include other genetic modifications that facilitate or optimize acetyl-CoA biosynthesis or that confer other useful functions onto the host microbial

organism. One such other functionality can include, for example, augmentation of the synthesis of one or more of the acetyl-CoA pathway precursors such as methanol.

Generally, a host microbial organism is selected such that it produces the precursor of an acetyl-CoA pathway, either as a naturally produced molecule or as an engineered product that either provides *de novo* production of a desired precursor or increased production of a precursor naturally produced by the host microbial organism. A host organism can be engineered to increase production of a precursor, as disclosed herein. In addition, a microbial organism that has been engineered to produce a desired precursor can be used as a host organism and further engineered to express enzymes or proteins of an acetyl-CoA pathway.

10 In some embodiments, a non-naturally occurring microbial organism of the invention is generated from a host that contains the enzymatic capability to synthesize acetyl-CoA. In this specific embodiment it can be useful to increase the synthesis or accumulation of an acetyl-CoA pathway product to, for example, drive acetyl-CoA pathway reactions toward acetyl-CoA production. Increased synthesis or accumulation can be accomplished by, for example, overexpression of nucleic acids encoding one or more of the above-described acetyl-CoA pathway enzymes or proteins. Over expression the enzyme or enzymes and/or protein or proteins of the acetyl-CoA pathway can occur, for example, through exogenous expression of the endogenous gene or genes, or through exogenous expression of the heterologous gene or genes. Therefore, naturally occurring organisms can be readily generated to be non-naturally occurring microbial organisms of the invention, for example, producing acetyl-CoA, through overexpression of one, two, three, four, five, six, seven, eight, nine, or ten, that is, up to all nucleic acids encoding acetyl-CoA biosynthetic pathway enzymes or proteins. In addition, a non-naturally occurring organism can be generated by mutagenesis of an endogenous gene that results in an increase in activity of an enzyme in the acetyl-CoA biosynthetic pathway.

25 In particularly useful embodiments, exogenous expression of the encoding nucleic acids is employed. Exogenous expression confers the ability to custom tailor the expression and/or regulatory elements to the host and application to achieve a desired expression level that is controlled by the user. However, endogenous expression also can be utilized in other embodiments such as by removing a negative regulatory effector or induction of the gene's promoter when linked to an inducible promoter or other regulatory element. Thus, an endogenous gene having a naturally occurring inducible promoter can be up-regulated by providing the appropriate inducing agent, or the regulatory region of an endogenous gene can be engineered to incorporate an inducible regulatory element, thereby allowing the regulation of

increased expression of an endogenous gene at a desired time. Similarly, an inducible promoter can be included as a regulatory element for an exogenous gene introduced into a non-naturally occurring microbial organism.

It is understood that, in methods of the invention, any of the one or more exogenous nucleic acids can be introduced into a microbial organism to produce a non-naturally occurring microbial organism of the invention. The nucleic acids can be introduced so as to confer, for example, an acetyl-CoA biosynthetic pathway onto the microbial organism. Alternatively, encoding nucleic acids can be introduced to produce an intermediate microbial organism having the biosynthetic capability to catalyze some of the required reactions to confer acetyl-CoA biosynthetic capability. For example, a non-naturally occurring microbial organism having a acetyl-CoA biosynthetic pathway can comprise at least two exogenous nucleic acids encoding desired enzymes or proteins, such as the combination of methanol methyltransferase and corrinoid protein; methanol methyltransferase and methyltetrahydrofolate:corrinoid protein methyltransferase; corrinoid protein and corrinoid iron-sulfur protein; nickel-protein assembly protein and ferredoxin, and the like. Thus, it is understood that any combination of two or more enzymes or proteins of a biosynthetic pathway can be included in a non-naturally occurring microbial organism of the invention. Similarly, it is understood that any combination of three or more enzymes or proteins of a biosynthetic pathway can be included in a non-naturally occurring microbial organism of the invention, for example, methanol methyltransferase, corrinoid iron-sulfur protein (such as AcsD) and acetyl-CoA synthase; corrinoid protein (such as MtaC), carbon monoxide dehydrogenase and nickel-protein assembly protein (such as CooC or AcsF); methyltetrahydrofolate:corrinoid protein methyltransferase (such as AcsE), ferredoxin and acetyl-CoA synthase, and so forth, as desired, so long as the combination of enzymes and/or proteins of the desired biosynthetic pathway results in production of the corresponding desired product. Similarly, any combination of four, five, six, seven, eight, nine or more enzymes or proteins of a biosynthetic pathway as disclosed herein can be included in a non-naturally occurring microbial organism of the invention, as desired, so long as the combination of enzymes and/or proteins of the desired biosynthetic pathway results in production of the corresponding desired product.

In addition to the biosynthesis of acetyl-CoA as described herein, the non-naturally occurring microbial organisms and methods of the invention also can be utilized in various combinations with each other and with other microbial organisms and methods well known in the art to achieve product biosynthesis by other routes. For example, one alternative to produce acetyl-

CoA other than use of the acetyl-CoA producers is through addition of another microbial organism capable of converting an acetyl-CoA pathway intermediate to acetyl-CoA. One such procedure includes, for example, the fermentation of a microbial organism that produces an acetyl-CoA pathway intermediate. The acetyl-CoA pathway intermediate can then be used as a substrate for a second microbial organism that converts the acetyl-CoA pathway intermediate to acetyl-CoA. The acetyl-CoA pathway intermediate can be added directly to another culture of the second organism or the original culture of the acetyl-CoA pathway intermediate producers can be depleted of these microbial organisms by, for example, cell separation, and then subsequent addition of the second organism to the fermentation broth can be utilized to produce the final product without intermediate purification steps.

In other embodiments, the non-naturally occurring microbial organisms and methods of the invention can be assembled in a wide variety of subpathways to achieve biosynthesis of, for example, acetyl-CoA. In these embodiments, biosynthetic pathways for a desired product of the invention can be segregated into different microbial organisms, and the different microbial organisms can be co-cultured to produce the final product. In such a biosynthetic scheme, the product of one microbial organism is the substrate for a second microbial organism until the final product is synthesized. For example, the biosynthesis of acetyl-CoA can be accomplished by constructing a microbial organism that contains biosynthetic pathways for conversion of one pathway intermediate to another pathway intermediate or the product. Alternatively, acetyl-CoA also can be biosynthetically produced from microbial organisms through co-culture or co-fermentation using two organisms in the same vessel, where the first microbial organism produces an acetyl-CoA intermediate and the second microbial organism converts the intermediate to acetyl-CoA.

Given the teachings and guidance provided herein, those skilled in the art will understand that a wide variety of combinations and permutations exist for the non-naturally occurring microbial organisms and methods of the invention together with other microbial organisms, with the co-culture of other non-naturally occurring microbial organisms having subpathways and with combinations of other chemical and/or biochemical procedures well known in the art to produce acetyl-CoA. In addition, since acetyl-CoA is a precursor of other desirable products, a non-naturally occurring microbial organism of the invention can be used as a host organism into which other desired pathways utilizing acetyl-CoA as a precursor or intermediate can be conferred, as desired.

Sources of encoding nucleic acids for an acetyl-CoA pathway enzyme or protein can include, for example, any species where the encoded gene product is capable of catalyzing the referenced reaction. Such species include both prokaryotic and eukaryotic organisms including, but not limited to, bacteria, including archaea and eubacteria, and eukaryotes, including yeast, plant, insect, animal, and mammal, including human. Exemplary species for such sources include, for example, *Escherichia coli*, *Methanosarcina barkeri*, *Methanosarcina acetivorans*, *Moorella thermoacetica*, *Carboxydotherrmus hydrogenoformans*, *Rhodospirillum rubrum*, *Acetobacterium woodii*, *Butyribacterium methylotrophicum*, *Clostridium autoethanogenum*, *Clostridium carboxidivorans*, *Clostridium ljungdahlii*, *Eubacterium limosum*, *Oxobacter pfennigii*, *Peptostreptococcus productus*, *Rhodopseudomonas palustris P4*, *Rubrivivax gelatinosus*, *Citrobacter sp Y19*, *Methanosarcina acetivorans C2A*, *Methanosarcina barkeri*, *Desulfosporosinus orientis*, *Desulfovibrio desulfuricans*, *Desulfovibrio vulgaris*, *Moorella thermoautotrophica*, *Carboxydibrachium pacificus*, *Carboxydocella thermoautotrophica*, *Thermincola carboxydiphila*, *Thermolithobacter carboxydivorans*, *Thermosinus carboxydivorans*, *Methanothermobacter thermoautotrophicus*, *Desulfotomaculum carboxydivorans*, *Desulfotomaculum kuznetsovii*, *Desulfotomaculum nigrificans*, *Desulfotomaculum thermobenzoicum subsp. thermosyntrophicum*, *Syntrophobacter fumaroxidans*, *Clostridium acidurici*, *Desulfovibrio africanus*, and the like, as well as other exemplary species disclosed herein or available as source organisms for corresponding genes.

However, with the complete genome sequence available for now more than 550 species (with more than half of these available on public databases such as the NCBI), including 395 microorganism genomes and a variety of yeast, fungi, plant, and mammalian genomes, the identification of genes encoding the requisite acetyl-CoA biosynthetic activity for one or more genes in related or distant species, including for example, homologues, orthologs, paralogs and nonorthologous gene displacements of known genes, and the interchange of genetic alterations between organisms is routine and well known in the art. Accordingly, the metabolic alterations enabling biosynthesis of acetyl-CoA described herein with reference to a particular organism such as *E. coli* can be readily applied to other microorganisms, including prokaryotic and eukaryotic organisms alike. Given the teachings and guidance provided herein, those skilled in the art will know that a metabolic alteration exemplified in one organism can be applied equally to other organisms.

In some instances, such as when an alternative acetyl-CoA biosynthetic pathway exists in an unrelated species, acetyl-CoA biosynthesis can be conferred onto the host species by, for example, exogenous expression of a paralog or paralogs from the unrelated species that catalyzes

a similar, yet non-identical metabolic reaction to replace the referenced reaction. Because certain differences among metabolic networks exist between different organisms, those skilled in the art will understand that the actual gene usage between different organisms may differ.

5 However, given the teachings and guidance provided herein, those skilled in the art also will understand that the teachings and methods of the invention can be applied to all microbial organisms using the cognate metabolic alterations to those exemplified herein to construct a microbial organism in a species of interest that will synthesize acetyl-CoA.

Host microbial organisms can be selected from, and the non-naturally occurring microbial organisms generated in, for example, bacteria, yeast, fungus or any of a variety of other
10 microorganisms applicable to fermentation processes. Exemplary bacteria include species selected from *Escherichia coli*, *Klebsiella oxytoca*, *Anaerobiospirillum succiniciproducens*, *Actinobacillus succinogenes*, *Mannheimia succiniciproducens*, *Rhizobium etli*, *Bacillus subtilis*, *Corynebacterium glutamicum*, *Gluconobacter oxydans*, *Zymomonas mobilis*, *Lactococcus lactis*, *Lactobacillus plantarum*, *Streptomyces coelicolor*, *Clostridium acetobutylicum*, *Pseudomonas*
15 *fluorescens*, and *Pseudomonas putida*. Exemplary yeasts or fungi include species selected from *Saccharomyces cerevisiae*, *Schizosaccharomyces pombe*, *Kluyveromyces lactis*, *Kluyveromyces marxianus*, *Aspergillus terreus*, *Aspergillus niger* and *Pichia pastoris*. *E. coli* is a particularly useful host organisms since it is a well characterized microbial organism suitable for genetic engineering. Other particularly useful host organisms include yeast such as *Saccharomyces*
20 *cerevisiae*. Exemplary acetogens suitable as host organisms include, but are not limited to, *Rhodospirillum rubrum*, *Moorella thermoacetica* and *Desulfitobacterium hafniense* (see Examples).

Methods for constructing and testing the expression levels of a non-naturally occurring acetyl-CoA-producing host can be performed, for example, by recombinant and detection methods well
25 known in the art. Such methods can be found described in, for example, Sambrook et al., *Molecular Cloning: A Laboratory Manual*, Third Ed., Cold Spring Harbor Laboratory, New York (2001); and Ausubel et al., *Current Protocols in Molecular Biology*, John Wiley and Sons, Baltimore, MD (1999).

Exogenous nucleic acid sequences involved in a pathway for production of acetyl-CoA can be
30 introduced stably or transiently into a host cell using techniques well known in the art including, but not limited to, conjugation, electroporation, chemical transformation, transduction, transfection, and ultrasound transformation. For exogenous expression in *E. coli* or other prokaryotic cells, some nucleic acid sequences in the genes or cDNAs of eukaryotic nucleic

acids can encode targeting signals such as an N-terminal mitochondrial or other targeting signal, which can be removed before transformation into prokaryotic host cells, if desired. For example, removal of a mitochondrial leader sequence led to increased expression in *E. coli* (Hoffmeister et al., *J. Biol. Chem.* 280:4329-4338 (2005)). For exogenous expression in yeast or other
5 eukaryotic cells, genes can be expressed in the cytosol without the addition of leader sequence, or can be targeted to mitochondrion or other organelles, or targeted for secretion, by the addition of a suitable targeting sequence such as a mitochondrial targeting or secretion signal suitable for the host cells. Thus, it is understood that appropriate modifications to a nucleic acid sequence to remove or include a targeting sequence can be incorporated into an exogenous nucleic acid
10 sequence to impart desirable properties. Furthermore, genes can be subjected to codon optimization with techniques well known in the art to achieve optimized expression of the proteins.

An expression vector or vectors can be constructed to include one or more acetyl-CoA biosynthetic pathway encoding nucleic acids as exemplified herein operably linked to expression
15 control sequences functional in the host organism. Expression vectors applicable for use in the microbial host organisms of the invention include, for example, plasmids, phage vectors, viral vectors, episomes and artificial chromosomes, including vectors and selection sequences or markers operable for stable integration into a host chromosome. Additionally, the expression
20 vectors can include one or more selectable marker genes and appropriate expression control sequences. Selectable marker genes also can be included that, for example, provide resistance to antibiotics or toxins, complement auxotrophic deficiencies, or supply critical nutrients not in the culture media. Expression control sequences can include constitutive and inducible promoters, transcription enhancers, transcription terminators, and the like which are well known in the art. When two or more exogenous encoding nucleic acids are to be co-expressed, both nucleic acids
25 can be inserted, for example, into a single expression vector or in separate expression vectors. For single vector expression, the encoding nucleic acids can be operationally linked to one common expression control sequence or linked to different expression control sequences, such as one inducible promoter and one constitutive promoter. The transformation of exogenous nucleic acid sequences involved in a metabolic or synthetic pathway can be confirmed using methods
30 well known in the art. Such methods include, for example, nucleic acid analysis such as Northern blots or polymerase chain reaction (PCR) amplification of mRNA, or immunoblotting for expression of gene products, or other suitable analytical methods to test the expression of an introduced nucleic acid sequence or its corresponding gene product. It is understood by those skilled in the art that the exogenous nucleic acid is expressed in a sufficient amount to produce

the desired product, and it is further understood that expression levels can be optimized to obtain sufficient expression using methods well known in the art and as disclosed herein.

The invention additionally provides a method for producing acetyl-CoA by culturing a non-naturally occurring microbial organism of the invention having an acetyl-CoA pathway. The acetyl-CoA pathway can comprise, for example, at least one exogenous nucleic acid encoding an acetyl-CoA pathway enzyme or protein expressed in a sufficient amount to produce acetyl-CoA, under conditions and for a sufficient period of time to produce acetyl-CoA, the acetyl-CoA pathway comprising methanol-methyltransferase and acetyl-CoA synthase/carbon monoxide dehydrogenase. In such an acetyl-CoA pathway, the methanol-methyltransferase can comprise an enzyme or protein selected from methanol methyltransferase, corrinoid protein (such as MtaC) and methyltetrahydrofolate:corrinoid protein methyltransferase (MtaA). Further, in such an acetyl-CoA pathway, the acetyl-CoA synthase/carbon monoxide dehydrogenase can comprise an enzyme or protein selected from methyltetrahydrofolate:corrinoid protein methyltransferase (such as AcsE), corrinoid iron-sulfur protein (such as AcsD), nickel-protein assembly protein (such as AcsF), ferredoxin, acetyl-CoA synthase, carbon monoxide dehydrogenase and nickel-protein assembly protein (such as CooC). A non-naturally occurring microbial organism can be in a substantially anaerobic culture medium. In a particular embodiment, the non-naturally occurring microbial organism can be cultured in the presence of CO₂, CO and/or H₂, that is, a combination thereof, and methanol. The non-naturally occurring microbial organism can further comprise pyruvate ferredoxin oxidoreductase, which can be expressed by an exogenous nucleic acid. The non-naturally occurring microbial organism can also further comprise hydrogenase, for example, encoded by an endogenous or exogenous nucleic acid.

In another embodiment, the non-naturally occurring microbial organism can be cultured in the presence of an electron acceptor, for example, nitrate, in particular under substantially anaerobic conditions (see Example III). It is understood that an appropriate amount of nitrate can be added to a microbial culture to achieve a desired increase in biomass, for example, 1 mM to 100 mM nitrate, or lower or higher concentrations, as desired, so long as the amount added provides a sufficient amount of electron acceptor for the desired increase in biomass. Such amounts include, but are not limited to, 5 mM, 10 mM, 15 mM, 20 mM, 25 mM, 30 mM, 40 mM, 50 mM, as appropriate to achieve a desired increase in biomass.

Suitable purification and/or assays to test for the production of acetyl-CoA can be performed using well known methods. Suitable replicates such as triplicate cultures can be grown for each engineered strain to be tested. For example, product and byproduct formation in the engineered

production host can be monitored. The final product and intermediates, and other organic compounds, can be analyzed by methods such as HPLC (High Performance Liquid Chromatography), GC-MS (Gas Chromatography-Mass Spectroscopy) and LC-MS (Liquid Chromatography-Mass Spectroscopy) or other suitable analytical methods using routine
5 procedures well known in the art. The release of product in the fermentation broth can also be tested with the culture supernatant. Byproducts and residual glucose can be quantified by HPLC using, for example, a refractive index detector for glucose and alcohols, and a UV detector for organic acids (Lin et al., *Biotechnol. Bioeng.* 90:775-779 (2005)), or other suitable assay and detection methods well known in the art. The individual enzyme or protein activities from the
10 exogenous DNA sequences can also be assayed using methods well known in the art (see Example III).

The acetyl-CoA, or products derived from acetyl-CoA, can be separated from other components in the culture using a variety of methods well known in the art. Products derived from acetyl-CoA include, but are not limited to, ethanol, butanol, isobutanol, isopropanol, 1,4-butanediol,
15 succinic acid, fumaric acid, malic acid, 4-hydroxybutyric acid, 3-hydroxypropionic acid, lactic acid, methacrylic acid, adipic acid, and acrylic acid. Such separation methods include, for example, extraction procedures as well as methods that include continuous liquid-liquid extraction, pervaporation, membrane filtration, membrane separation, reverse osmosis, electro dialysis, distillation, crystallization, centrifugation, extractive filtration, ion exchange
20 chromatography, size exclusion chromatography, adsorption chromatography, and ultrafiltration. All of the above methods are well known in the art.

Any of the non-naturally occurring microbial organisms described herein can be cultured to produce and/or secrete the biosynthetic products of the invention. For example, the acetyl-CoA producers can be cultured for the biosynthetic production of acetyl-CoA, or products derived
25 from acetyl-CoA.

For the production of acetyl-CoA, the recombinant strains are cultured in a medium with a carbon and energy source of methanol and gases comprising CO, CO₂ and/or H₂ and other essential nutrients. It is highly desirable to maintain anaerobic conditions in the fermenter to reduce the cost of the overall process. Such conditions can be obtained, for example, by first
30 sparging the medium with nitrogen and then sealing the flasks with a septum and crimp-cap. For strains where growth is not observed anaerobically, microaerobic conditions can be applied by perforating the septum with a small hole for limited aeration. Exemplary anaerobic conditions have been described previously and are well-known in the art. Exemplary aerobic and anaerobic

conditions are described, for example, in United State Patent application serial No. 11/891,602, filed August 10, 2007, and WO/2008/115840. Fermentations can be performed in a batch, fed-batch or continuous manner, as disclosed herein.

If desired, the pH of the medium can be maintained at a desired pH, in particular neutral pH, such as a pH of around 7 by addition of a base, such as NaOH or other bases, or acid, as needed to maintain the culture medium at a desirable pH. The growth rate can be determined by measuring optical density using a spectrophotometer (600 nm), and the glucose uptake rate by monitoring carbon source depletion over time.

The growth medium can include, for example, any carbohydrate source which can supply a source of carbon to the non-naturally occurring microorganism. Such sources include, for example, sugars such as glucose, xylose, arabinose, galactose, mannose, fructose and starch. Other sources of carbohydrate include, for example, renewable feedstocks and biomass. Exemplary types of biomasses that can be used as feedstocks in the methods of the invention include cellulosic biomass, hemicellulosic biomass and lignin feedstocks or portions of feedstocks. Such biomass feedstocks contain, for example, carbohydrate substrates useful as carbon sources such as glucose, xylose, arabinose, galactose, mannose, fructose and starch. Given the teachings and guidance provided herein, those skilled in the art will understand that renewable feedstocks and biomass other than those exemplified above also can be used for culturing the microbial organisms of the invention for the production of acetyl-CoA.

Accordingly, given the teachings and guidance provided herein, those skilled in the art will understand that a non-naturally occurring microbial organism can be produced that expresses intracellular or secretes the biosynthesized compounds of the invention when grown on a carbon source such as a carbohydrate, methanol, and gases comprising CO, CO₂, and/or H₂. Such compounds include, for example, acetyl-CoA and any of the intermediate metabolites in the acetyl-CoA pathway, and products derived from acetyl-CoA including ethanol, butanol, isobutanol, isopropanol, 1,4-butanediol, succinic acid, fumaric acid, malic acid, 4-hydroxybutyric acid, 3-hydroxypropionic acid, lactic acid, methacrylic acid, adipic acid, and acrylic acid. All that is required is to engineer in one or more of the required enzyme or protein activities to achieve biosynthesis of the desired compound or intermediate including, for example, inclusion of some or all of the acetyl-CoA biosynthetic pathways. Accordingly, the invention provides a non-naturally occurring microbial organism that produces acetyl-CoA when grown on a carbohydrate or other carbon source and produces and/or secretes any of the intermediate metabolites shown in the acetyl-CoA pathway or produces and/or secretes a product

derived from acetyl-CoA when grown on a carbohydrate or other carbon source. The acetyl-CoA producing microbial organisms of the invention can initiate synthesis from an intermediate, for example, 5-methyl-tetrahydrofolate (Me-THF).

The non-naturally occurring microbial organisms of the invention are constructed using methods well known in the art as exemplified herein to exogenously express at least one nucleic acid encoding an acetyl-CoA pathway enzyme or protein in sufficient amounts to produce acetyl-CoA. It is understood that the microbial organisms of the invention are cultured under conditions sufficient to produce acetyl-CoA. Following the teachings and guidance provided herein, the non-naturally occurring microbial organisms of the invention can achieve biosynthesis of acetyl-CoA resulting in intracellular concentrations between about 0.001-200 mM or more. Generally, the intracellular concentration of acetyl-CoA is between about 3-150 mM, particularly between about 5-125 mM and more particularly between about 8-100 mM, including about 10 mM, 20 mM, 50 mM, 80 mM, or more. Intracellular concentrations between and above each of these exemplary ranges also can be achieved from the non-naturally occurring microbial organisms of the invention.

In some embodiments, culture conditions include anaerobic or substantially anaerobic growth or maintenance conditions. Exemplary anaerobic conditions have been described previously and are well known in the art. Exemplary anaerobic conditions for fermentation processes are described herein and are described, for example, in U.S. patent application serial No. 11/891,602, filed August 10, 2007, and WO/2008/115840. Any of these conditions can be employed with the non-naturally occurring microbial organisms as well as other anaerobic conditions well known in the art. Under such anaerobic conditions, the acetyl-CoA producers can synthesize acetyl-CoA at intracellular concentrations of 5-10 mM or more as well as all other concentrations exemplified herein. It is understood that the above description refers to intracellular concentrations, and acetyl-CoA producing microbial organisms can produce acetyl-CoA intracellularly. In addition, a product derived from acetyl-CoA can be produced intracellularly and/or secreted. Such products include, but are not limited to, ethanol, butanol, isobutanol, isopropanol, 1,4-butanediol, succinic acid, fumaric acid, malic acid, 4-hydroxybutyric acid, 3-hydroxypropionic acid, lactic acid, methacrylic acid, adipic acid, and acrylic acid.

The culture conditions can include, for example, liquid culture procedures as well as fermentation and other large scale culture procedures. As described herein, particularly useful yields of the biosynthetic products of the invention can be obtained under anaerobic or substantially anaerobic culture conditions.

As described herein, one exemplary growth condition for achieving biosynthesis of acetyl-CoA includes anaerobic culture or fermentation conditions. In certain embodiments, the non-naturally occurring microbial organisms of the invention can be sustained, cultured or fermented under anaerobic or substantially anaerobic conditions. Briefly, anaerobic conditions refers to an environment devoid of oxygen. Substantially anaerobic conditions include, for example, a culture, batch fermentation or continuous fermentation such that the dissolved oxygen concentration in the medium remains between 0 and 10% of saturation. Substantially anaerobic conditions also includes growing or resting cells in liquid medium or on solid agar inside a sealed chamber maintained with an atmosphere of less than 1% oxygen. The percent of oxygen can be maintained by, for example, sparging the culture with an N₂/CO₂ mixture or other suitable non-oxygen gas or gases.

The culture conditions described herein can be scaled up and grown continuously for manufacturing of acetyl-CoA. Exemplary growth procedures include, for example, fed-batch fermentation and batch separation; fed-batch fermentation and continuous separation, or continuous fermentation and continuous separation. All of these processes are well known in the art. Fermentation procedures are particularly useful for the biosynthetic production of commercial quantities of acetyl-CoA. Generally, and as with non-continuous culture procedures, the continuous and/or near-continuous production of acetyl-CoA will include culturing a non-naturally occurring acetyl-CoA producing organism of the invention in sufficient nutrients and medium to sustain and/or nearly sustain growth in an exponential phase. Continuous culture under such conditions can be include, for example, 1 day, 2, 3, 4, 5, 6 or 7 days or more. Additionally, continuous culture can include 1 week, 2, 3, 4 or 5 or more weeks and up to several months. Alternatively, organisms of the invention can be cultured for hours, if suitable for a particular application. It is to be understood that the continuous and/or near-continuous culture conditions also can include all time intervals in between these exemplary periods. It is further understood that the time of culturing the microbial organism of the invention is for a sufficient period of time to produce a sufficient amount of product for a desired purpose.

Fermentation procedures are well known in the art. Briefly, fermentation for the biosynthetic production of acetyl-CoA can be utilized in, for example, fed-batch fermentation and batch separation; fed-batch fermentation and continuous separation, or continuous fermentation and continuous separation. Examples of batch and continuous fermentation procedures are well known in the art.

In addition to the above fermentation procedures using the acetyl-CoA producers of the invention for continuous production of substantial quantities of acetyl-CoA, the acetyl-CoA producers also can be, for example, simultaneously subjected to chemical synthesis procedures to convert the product to other compounds or the product can be separated from the fermentation culture and sequentially subjected to chemical conversion to convert the product to other compounds, if desired.

At least thirty different wild-type organisms have been isolated through the years and shown to grow on syngas or components of syngas, including microorganisms capable of converting syngas to ethanol (Vega et al., Appl. Biochem. Biotechnol. 20/21:781-797 (1989))(see Table 1). Candidate organisms for improved syngas fermentation include acetogens, phototrophs, sulfate reducing bacteria, and methanogens, which can utilize CO and/or CO₂/H₂ as the sole carbon and energy source (Sipma et al., Crit. Rev. Biotechnol. 26:41-65. (2006)). The mesophilic acetogen *Clostridium carboxidivorans* represents one of the most promising organisms for a syngas-to-chemicals platform as it has fast doubling times and have been shown to naturally produce ethanol and small quantities of butanol during growth on syngas (Henstra et al., Curr. Opin. Biotechnol. 18:200-206 (2007)). Genetic tools can be developed for this organism. The hydrogenic purple nonsulfur bacteria, *Rhodospirillum rubrum*, for which genetic tools exist for targeted gene deletions or insertions, is another good candidate organism for development of syngas utilization to produce desired products, although it naturally produces hydrogen from syngas and so metabolic changes can be engineered, as required.

The metabolism of some syngas utilizing organisms is known. For example, acetogens such as *C. carboxidivorans* can grow in the presence of CO or CO₂ by utilizing the Wood-Ljungdahl pathway, even in the absence of glucose, as long as hydrogen is present to supply the necessary reducing equivalents. The Wood-Ljungdahl pathway is illustrated in Figure 3 (see also Figures 1 and 2) and shows the capacity of acetogens to utilize CO as the sole carbon and energy source through the production of the key metabolic intermediate acetyl-CoA. Specifically, CO can be oxidized to produce reducing equivalents and CO₂, or can be directly assimilated into acetyl-CoA, which is subsequently converted to either biomass or metabolites. Importantly, acetyl-CoA is a key metabolic intermediate that can serve as a precursor to a wide range of metabolites and other chemical entities. Hence, the ability of a microorganism to produce acetyl-CoA from syngas or other gaseous carbon source allows engineering of syngas-utilizing organisms, or organisms capable of utilizing other gaseous carbon sources, for production of a wide range of chemicals and fuels as desired products.

In order to characterize the use of syngas or other gaseous carbon sources as a viable feedstock for the commercial production of chemicals and fuels through fermentation, feasibility studies are performed to address key questions and challenges associated with current systems.

Preliminary metabolic modeling efforts have indicated that conversion of syngas to chemicals
5 can be thermodynamically very favorable, and that specific chemicals can be made as the exclusive product. Not only does this reduce downstream processing needs, but also maximizes product yield. Furthermore, production of a desired product can be growth-associated, so that the fermentation can be done continuously, if desired. Because continuous processes are maintained at high cell concentration, and avoid batch turnaround time, they are more
10 economically favorable.

As disclosed herein, the present invention relates to the development of microorganisms capable of utilizing syngas or other gaseous carbon sources, allowing the efficient conversion of CO and/or CO₂ to chemical products in high yield, titer, and productivity. One exemplary useful commercial embodiment relates to the development of an organism that can achieve production
15 of a specific chemical with yields $\geq 80\%$ of theoretical maximum, product tolerance ≥ 50 g/L, titers ≥ 50 g/L and productivity of at least 2 g/L/h. Although these criteria are particularly useful commercially, it is understood that an organism capable of achieving less than any or all of these criteria is also useful in the invention. For example, an organism can achieve production of a specific chemical with yields greater than or equal to any of 75%, 70%, 65%, 60%, 55%, 50%,
20 45%, 40%, 35%, 30%, 25%, 20%, and so forth so long as sufficient yields are achieved for a desired application. Similarly, an organism can achieve product tolerance greater than or equal to any of 45 g/L, 40 g/L, 35 g/L, 30 g/L, 25 g/L, 20 g/L, 15 g/L, 10 g/L, and so forth so long as sufficient yields are achieved for a desired application. Moreover, an organism can achieve titers greater than or equal to any of 200 g/L, 190 g/L, 180 g/L, 170 g/L, 160 g/L, 150 g/L, 140 g/L,
25 130 g/L, 120 g/L, 110 g/L, 100 g/L, 90 g/L, 80 g/L, 70 g/L, 60 g/L, 50 g/L, 45 g/L, 40 g/L, 35 g/L, 30 g/L, 25 g/L, 20 g/L, 15 g/L, 10 g/L, and so forth so long as sufficient yields are achieved for a desired application. In addition, an organism can achieve productivity of at least any of 1.5 g/L/h, 1 g/L/h, 0.5 g/L/h, and so forth so long as sufficient yields are achieved for a desired application.

30 As disclosed herein, the hypothetical analysis of butanol as a product from syngas utilization indicates that the ability to efficiently utilize cheap and readily available syngas as a feedstock and can lead to processes that potentially are $\geq 50\%$ cost-advantaged over current petrochemical processes, especially in view of the low cost of syngas as a feedstock. In addition to low cost,

syngas is an abundant and flexible substrate that can be produced from coal and many types of biomass, including energy crops such as switchgrass, as well as waste products such as wood waste, agricultural waste, dairy waste, and municipal solid waste. Thus, the ability to generate organisms capable of utilizing syngas or other gaseous carbon sources to produce a desired product allows production from almost any biomass source. This feature obviates the need to develop different processes specific for each type of biomass used for biofuel or chemical production. The use of waste products for the production of syngas can also be utilized to decrease environmental pollutants and alleviate serious disposal problems of biowaste materials. In addition, syngas as a feedstock does not suffer from a feed versus fuel controversy associated with, for example, corn-based ethanol production. Given the broad range of substrates available for syngas production, the supply and cost structure of this feedstock is expected to remain relatively stable from year to year. Finally, syngas is used extensively for heating and energy and can therefore be used as a source of biomass-derived energy that can supplement or eliminate the need for petroleum-based energy for production, providing additional cost savings.

Although exemplified in various embodiments herein with butanol as a desired product, it is understood that any product capable of being produced by a microorganism of the invention can be generated and utilized to produce the product, as desired. Generally, desired products include but are not limited to hydrocarbons useful in chemical synthesis or as a fuel. Exemplary desired products include but are not limited to methanol, ethanol, butanol, acetate, butyrate, lactate, succinate, 4-hydroxybutyrate, 1,4-butanediol, and the like.

In other aspects, the present invention provides a non-naturally occurring microbial organism having a 4-hydroxybutyrate pathway that can include at least one exogenous nucleic acid encoding an 4-hydroxybutyrate pathway enzyme expressed in a sufficient amount to produce 4-hydroxybutyrate. The 4-hydroxybutyrate pathway enzyme can include an acetoacetyl-CoA thiolase, a 3-hydroxybutyryl-CoA dehydrogenase, a crotonase, a crotonyl-CoA hydratase, a 4-hydroxybutyryl-CoA transferase, a phosphotrans-4-hydroxybutyrylase, and a 4-hydroxybutyrate kinase.

In still other aspects, the present invention provides a non-naturally occurring microbial organism having a 1,4-butanediol pathway that can include at least one exogenous nucleic acid encoding a 1,4-butanediol pathway enzyme expressed in a sufficient amount to produce 1,4-butanediol. The 1,4-butanediol pathway enzyme can include an acetoacetyl-CoA thiolase, a 3-Hydroxybutyryl-CoA dehydrogenase, a crotonase, a crotonyl-CoA hydratase, a 4-hydroxybutyryl-CoA reductase (alcohol forming), a 4-hydroxybutyryl-CoA reductase (aldehyde

forming), and a 1,4-butanediol dehydrogenase. Such an organism also can include an acetyl-CoA pathway having at least one exogenous nucleic acid encoding an acetyl-CoA pathway enzyme expressed in a sufficient amount to produce acetyl-CoA. The acetyl-CoA pathway enzyme can include a corrinoid protein, a methyltetrahydrofolate:corrinoid protein
5 methyltransferase, a corrinoid iron-sulfur protein, a nickel-protein assembly protein, a ferredoxin, an acetyl-CoA synthase, a carbon monoxide dehydrogenase, a pyruvate ferredoxin oxidoreductase, and a hydrogenase.

In yet other aspects, the present invention provides a non-naturally occurring microbial organism having a 1,4-butanediol pathway that can include at least one exogenous nucleic acid encoding a
10 1,4-butanediol pathway enzyme expressed in a sufficient amount to produce 1,4-butanediol. The 1,4-butanediol pathway enzyme can include an acetoacetyl-CoA thiolase, a 3-Hydroxybutyryl-CoA dehydrogenase, a crotonase, a crotonyl-CoA hydratase, a 4-hydroxybutyryl-CoA reductase (alcohol forming), a 4-hydroxybutyryl-CoA reductase (aldehyde forming), and a 1,4-butanediol dehydrogenase. Such an organism also can include an acetyl-CoA pathway having at least one
15 exogenous nucleic acid encoding an acetyl-CoA pathway enzyme expressed in a sufficient amount to produce acetyl-CoA. The acetyl-CoA pathway enzyme can include an acetyl-CoA synthase, a formate dehydrogenase, a formyltetrahydrofolate synthetase, a methenyltetrahydrofolate cyclohydrolase, a methylenetetrahydrofolate dehydrogenase, and a methylenetetrahydrofolate reductase.

20 In yet still further aspects, the present invention provides a method for producing 4-hydroxybutyrate that can include culturing a non-naturally occurring microbial organism having an 4-hydroxybutyrate pathway. The pathway can include at least one exogenous nucleic acid encoding an 4-hydroxybutyrate pathway enzyme expressed in a sufficient amount to produce 4-hydroxybutyrate under conditions and for a sufficient period of time to produce 4-
25 hydroxybutyrate. The 4-hydroxybutyrate pathway can include an acetoacetyl-CoA thiolase, a 3-hydroxybutyryl-CoA dehydrogenase, a crotonase, a crotonyl-CoA hydratase, a 4-hydroxybutyryl-CoA transferase, a phosphotrans-4-hydroxybutyrylase, and a 4-hydroxybutyrate kinase.

In still other aspects, the present invention provides a method for producing 1,4-butanediol that
30 can include culturing a non-naturally occurring microbial organism having an 1,4-butanediol pathway. The pathway can include at least one exogenous nucleic acid encoding an 1,4-butanediol pathway enzyme expressed in a sufficient amount to produce 1,4-butanediol under conditions and for a sufficient period of time to produce 1,4-butanediol. The 1,4-butanediol

pathway can include an acetoacetyl-CoA thiolase, a 3-hydroxybutyryl-CoA dehydrogenase, a crotonase, a crotonyl-CoA hydratase, a 4-hydroxybutyryl-CoA reductase (alcohol forming), a 4-hydroxybutyryl-CoA reductase (aldehyde forming), a 1,4-butanediol dehydrogenase. Such an organism also can include an acetyl-CoA pathway comprising at least one exogenous nucleic acid encoding an acetyl-CoA pathway enzyme expressed in a sufficient amount to produce acetyl-CoA. The acetyl-CoA pathway enzyme can include a corrinoid protein, a methyltetrahydro-folate:corrinoid protein methyltransferase, a corrinoid iron-sulfur protein, a nickel-protein assembly protein, a ferredoxin, an acetyl-CoA synthase, a carbon monoxide dehydrogenase, a pyruvate ferredoxin oxidoreductase, and a hydrogenase.

10 Finally, in some aspects, the present invention provides a method for producing 1,4-butanediol that can include culturing a non-naturally occurring microbial organism having an 1,4-butanediol pathway. The pathway can include at least one exogenous nucleic acid encoding an 1,4-butanediol pathway enzyme expressed in a sufficient amount to produce 1,4-butanediol under conditions and for a sufficient period of time to produce 1,4-butanediol. The 1,4-butanediol pathway can include an acetoacetyl-CoA thiolase, a 3-hydroxybutyryl-CoA dehydrogenase, a crotonase, a crotonyl-CoA hydratase, a 4-hydroxybutyryl-CoA reductase (alcohol forming), a 4-hydroxybutyryl-CoA reductase (aldehyde forming), and a 1,4-butanediol dehydrogenase. Such an organism also can include an acetyl-CoA pathway having at least one exogenous nucleic acid encoding an acetyl-CoA pathway enzyme expressed in a sufficient amount to produce acetyl-CoA. The acetyl-CoA pathway enzyme can include an acetyl-CoA synthase, a formate dehydrogenase, a formyltetrahydrofolate synthetase, a methenyltetrahydrofolate cyclohydrolase, a methylenetetrahydrofolate dehydrogenase, and a methylenetetrahydrofolate reductase.

In other embodiments, organisms of the present invention have a functional methyltransferase system, the ability to synthesize acetyl-CoA, and the ability to synthesize 4-HB from acetyl-CoA as depicted in Figure 11. Still other organisms described herein have a functional methyltransferase system, the ability to synthesize acetyl-CoA, and the ability to synthesize BDO from acetyl-CoA depicted in Figure 12.

The invention also provides a non-naturally occurring microbial organism having a 4-hydroxybutyrate pathway that can include at least one exogenous nucleic acid encoding an 4-hydroxybutyrate pathway enzyme expressed in a sufficient amount to produce 4-hydroxybutyrate. The 4-hydroxybutyrate pathway enzyme can include an acetoacetyl-CoA thiolase, a 3-hydroxybutyryl-CoA dehydrogenase, a crotonase, a crotonyl-CoA hydratase, a 4-

hydroxybutyryl-CoA transferase, a phosphotrans-4-hydroxybutyrylase, and a 4-hydroxybutyrate kinase.

Such organisms can also include at least one enzyme or polypeptide such as a corrinoid protein, a methyltetrahydrofolate:corrinoid protein methyltransferase, a corrinoid iron-sulfur protein, a
5 nickel-protein assembly protein, a ferredoxin, an acetyl-CoA synthase, a carbon monoxide dehydrogenase, a pyruvate ferredoxin oxidoreductase, and a hydrogenase.

In some embodiments, organisms that have a 4-hydroxybutyrate pathway can include a methanol methyltransferase. Such organisms utilize a feedstock such as 1) methanol and CO, 2) methanol, CO₂, and H₂, 3) methanol, CO, CO₂, and H₂, 4) methanol and synthesis gas comprising CO and
10 H₂, and 5) methanol and synthesis gas comprising CO, CO₂, and H₂.

Other organisms that have a 4-hydroxybutyrate pathway can have a formate dehydrogenase, a formyltetrahydrofolate synthetase, a methenyltetrahydrofolate cyclohydrolase, a methylenetetrahydrofolate dehydrogenase, and a methylenetetrahydrofolate reductase. Such organisms utilize a feedstock such as 1) CO, 2) CO₂ and H₂, 3) CO and CO₂, 4) synthesis gas
15 comprising CO and H₂, and 5) synthesis gas comprising CO, CO₂, and H₂.

The present invention also provides a non-naturally occurring microbial organism having a 1,4-butanediol pathway that can include at least one exogenous nucleic acid encoding a 1,4-butanediol pathway enzyme expressed in a sufficient amount to produce 1,4-butanediol. The 1,4-butanediol pathway enzyme include, for example, an acetoacetyl-CoA thiolase, a 3-
20 Hydroxybutyryl-CoA dehydrogenase, a crotonase, a crotonyl-CoA hydratase, a 4-hydroxybutyryl-CoA reductase (alcohol forming), a 4-hydroxybutyryl-CoA reductase (aldehyde forming), and a 1,4-butanediol dehydrogenase.

Such organisms can also include at least one enzyme or polypeptide such as a corrinoid protein, a methyltetrahydrofolate:corrinoid protein methyltransferase, a corrinoid iron-sulfur protein, a
25 nickel-protein assembly protein, a ferredoxin, an acetyl-CoA synthase, a carbon monoxide dehydrogenase, a pyruvate ferredoxin oxidoreductase, and a hydrogenase.

In some embodiments, an organism having a 1,4-butanediol pathway can include a methanol methyltransferase. Such organisms utilize a feedstock such as 1) methanol and CO, 2) methanol, CO₂, and H₂, 3) methanol, CO, CO₂, and H₂, 4) methanol and synthesis gas comprising CO and
30 H₂, and 5) methanol and synthesis gas comprising CO, CO₂, and H₂.

In other embodiments, an organism having a 1,4-butanediol pathway can include a formate dehydrogenase, a formyltetrahydrofolate synthetase, a methenyltetrahydrofolate cyclohydrolase, a methylenetetrahydrofolate dehydrogenase, and a methylenetetrahydrofolate reductase. Such organisms utilize a feedstock selected from the group consisting of: 1) CO, 2) CO₂ and H₂, 3) CO and CO₂, 4) synthesis gas comprising CO and H₂, and 5) synthesis gas comprising CO, CO₂, and H₂.

An exemplary microbial organisms of the invention can contain a pathway as depicted in Figure 13. Such an organism can contain a functional methyl branch of the Wood-Ljungdahl pathway, the ability to synthesize acetyl-CoA, and the ability to synthesize 4-hydroxybutyrate from acetyl-CoA. Another exemplary microbial organism of the invention can contain a pathway as depicted in Figure 14. Such a microbial organism can contain a functional methyl branch of the Wood-Ljungdahl pathway, the ability to synthesize acetyl-CoA, and the ability to synthesize 1,4-butanediol from acetyl-CoA.

To generate better producers, metabolic modeling can be utilized to optimize growth conditions. Modeling can also be used to design gene knockouts that additionally optimize utilization of the pathway (see, for example, U.S. patent publications US 2002/0012939, US 2003/0224363, US 2004/0029149, US 2004/0072723, US 2003/0059792, US 2002/0168654 and US 2004/0009466, and U.S. Patent No. 7,127,379). Modeling analysis allows reliable predictions of the effects on cell growth of shifting the metabolism towards more efficient production of acetyl-CoA or products derived from acetyl-CoA.

One computational method for identifying and designing metabolic alterations favoring biosynthesis of a desired product is the OptKnock computational framework (Burgard et al., *Biotechnol. Bioeng.* 84:647-657 (2003)). OptKnock is a metabolic modeling and simulation program that suggests gene deletion strategies that result in genetically stable microorganisms which overproduce the target product. Specifically, the framework examines the complete metabolic and/or biochemical network of a microorganism in order to suggest genetic manipulations that force the desired biochemical to become an obligatory byproduct of cell growth. By coupling biochemical production with cell growth through strategically placed gene deletions or other functional gene disruption, the growth selection pressures imposed on the engineered strains after long periods of time in a bioreactor lead to improvements in performance as a result of the compulsory growth-coupled biochemical production. Lastly, when gene deletions are constructed there is a negligible possibility of the designed strains reverting to their wild-type states because the genes selected by OptKnock are to be completely removed from the

genome. Therefore, this computational methodology can be used to either identify alternative pathways that lead to biosynthesis of a desired product or used in connection with the non-naturally occurring microbial organisms for further optimization of biosynthesis of a desired product.

5 Briefly, OptKnock is a term used herein to refer to a computational method and system for modeling cellular metabolism. The OptKnock program relates to a framework of models and methods that incorporate particular constraints into flux balance analysis (FBA) models. These constraints include, for example, qualitative kinetic information, qualitative regulatory information, and/or DNA microarray experimental data. OptKnock also computes solutions to
10 various metabolic problems by, for example, tightening the flux boundaries derived through flux balance models and subsequently probing the performance limits of metabolic networks in the presence of gene additions or deletions. OptKnock computational framework allows the construction of model formulations that enable an effective query of the performance limits of metabolic networks and provides methods for solving the resulting mixed-integer linear
15 programming problems. The metabolic modeling and simulation methods referred to herein as OptKnock are described in, for example, U.S. publication 2002/0168654, filed January 10, 2002, in International Patent No. PCT/US02/00660, filed January 10, 2002, and U.S. patent application serial No. 11/891,602, filed August 10, 2007, and WO/2008/115840.

Another computational method for identifying and designing metabolic alterations favoring
20 biosynthetic production of a product is a metabolic modeling and simulation system termed SimPheny®. This computational method and system is described in, for example, U.S. publication 2003/0233218, filed June 14, 2002, and in International Patent Application No. PCT/US03/18838, filed June 13, 2003. SimPheny® is a computational system that can be used to produce a network model *in silico* and to simulate the flux of mass, energy or charge through
25 the chemical reactions of a biological system to define a solution space that contains any and all possible functionalities of the chemical reactions in the system, thereby determining a range of allowed activities for the biological system. This approach is referred to as constraints-based modeling because the solution space is defined by constraints such as the known stoichiometry of the included reactions as well as reaction thermodynamic and capacity constraints associated
30 with maximum fluxes through reactions. The space defined by these constraints can be interrogated to determine the phenotypic capabilities and behavior of the biological system or of its biochemical components.

These computational approaches are consistent with biological realities because biological systems are flexible and can reach the same result in many different ways. Biological systems are designed through evolutionary mechanisms that have been restricted by fundamental constraints that all living systems must face. Therefore, constraints-based modeling strategy
5 embraces these general realities. Further, the ability to continuously impose further restrictions on a network model via the tightening of constraints results in a reduction in the size of the solution space, thereby enhancing the precision with which physiological performance or phenotype can be predicted.

Given the teachings and guidance provided herein, those skilled in the art will be able to apply
10 various computational frameworks for metabolic modeling and simulation to design and implement biosynthesis of a desired compound in host microbial organisms. Such metabolic modeling and simulation methods include, for example, the computational systems exemplified above as SimPheny® and OptKnock. For illustration of the invention, some methods are described herein with reference to the OptKnock computation framework for modeling and
15 simulation. Those skilled in the art will know how to apply the identification, design and implementation of the metabolic alterations using OptKnock to any of such other metabolic modeling and simulation computational frameworks and methods well known in the art.

The methods described above will provide one set of metabolic reactions to disrupt. Elimination of each reaction within the set or metabolic modification can result in a desired product as an
20 obligatory product during the growth phase of the organism. Because the reactions are known, a solution to the bilevel OptKnock problem also will provide the associated gene or genes encoding one or more enzymes that catalyze each reaction within the set of reactions. Identification of a set of reactions and their corresponding genes encoding the enzymes participating in each reaction is generally an automated process, accomplished through
25 correlation of the reactions with a reaction database having a relationship between enzymes and encoding genes.

Once identified, the set of reactions that are to be disrupted in order to achieve production of a desired product are implemented in the target cell or organism by functional disruption of at least one gene encoding each metabolic reaction within the set. One particularly useful means to
30 achieve functional disruption of the reaction set is by deletion of each encoding gene. However, in some instances, it can be beneficial to disrupt the reaction by other genetic aberrations including, for example, mutation, deletion of regulatory regions such as promoters or cis binding sites for regulatory factors, or by truncation of the coding sequence at any of a number of

locations. These latter aberrations, resulting in less than total deletion of the gene set can be useful, for example, when rapid assessments of the coupling of a product are desired or when genetic reversion is less likely to occur.

To identify additional productive solutions to the above described bilevel OptKnock problem which lead to further sets of reactions to disrupt or metabolic modifications that can result in the biosynthesis, including growth-coupled biosynthesis of a desired product, an optimization method, termed integer cuts, can be implemented. This method proceeds by iteratively solving the OptKnock problem exemplified above with the incorporation of an additional constraint referred to as an integer cut at each iteration. Integer cut constraints effectively prevent the solution procedure from choosing the exact same set of reactions identified in any previous iteration that obligatorily couples product biosynthesis to growth. For example, if a previously identified growth-coupled metabolic modification specifies reactions 1, 2, and 3 for disruption, then the following constraint prevents the same reactions from being simultaneously considered in subsequent solutions. The integer cut method is well known in the art and can be found described in, for example, Burgard et al., *Biotechnol. Prog.* 17:791-797 (2001). As with all methods described herein with reference to their use in combination with the OptKnock computational framework for metabolic modeling and simulation, the integer cut method of reducing redundancy in iterative computational analysis also can be applied with other computational frameworks well known in the art including, for example, SimPheny®.

The methods exemplified herein allow the construction of cells and organisms that biosynthetically produce a desired product, including the obligatory coupling of production of a target biochemical product to growth of the cell or organism engineered to harbor the identified genetic alterations. Therefore, the computational methods described herein allow the identification and implementation of metabolic modifications that are identified by an *in silico* method selected from OptKnock or SimPheny®. The set of metabolic modifications can include, for example, addition of one or more biosynthetic pathway enzymes and/or functional disruption of one or more metabolic reactions including, for example, disruption by gene deletion.

As discussed above, the OptKnock methodology was developed on the premise that mutant microbial networks can be evolved towards their computationally predicted maximum-growth phenotypes when subjected to long periods of growth selection. In other words, the approach leverages an organism's ability to self-optimize under selective pressures. The OptKnock framework allows for the exhaustive enumeration of gene deletion combinations that force a

coupling between biochemical production and cell growth based on network stoichiometry. The identification of optimal gene/reaction knockouts requires the solution of a bilevel optimization problem that chooses the set of active reactions such that an optimal growth solution for the resulting network overproduces the biochemical of interest (Burgard et al., *Biotechnol. Bioeng.* 84:647-657 (2003)).

An *in silico* stoichiometric model of *E. coli* metabolism can be employed to identify essential genes for metabolic pathways as exemplified previously and described in, for example, U.S. patent publications US 2002/0012939, US 2003/0224363, US 2004/0029149, US 2004/0072723, US 2003/0059792, US 2002/0168654 and US 2004/0009466, and in U.S. Patent No. 7,127,379.

As disclosed herein, the OptKnock mathematical framework can be applied to pinpoint gene deletions leading to the growth-coupled production of a desired product. Further, the solution of the bilevel OptKnock problem provides only one set of deletions. To enumerate all meaningful solutions, that is, all sets of knockouts leading to growth-coupled production formation, an optimization technique, termed integer cuts, can be implemented. This entails iteratively solving the OptKnock problem with the incorporation of an additional constraint referred to as an integer cut at each iteration, as discussed above.

It is understood that modifications which do not substantially affect the activity of the various embodiments of this invention are also provided within the definition of the invention provided herein. Accordingly, the following examples are intended to illustrate but not limit the present invention.

EXAMPLE I **Organisms and Pathways for Syngas Fermentation**

This example describes organisms capable of utilizing syngas and exemplary pathways.

At least thirty different organisms have been isolated through the years and shown to grow on syngas or components of syngas such as CO, CO₂, and H₂ (Henstra et al., *Curr. Opin. Biotechnol.* 18:200-206 (2007); Sipma et al., *Crit. Rev. Biotechnol.* 26:41-65 (2006)). Table 1 provides examples of such organisms as well as a number of their properties such as their optimal temperature for growth, optimal pH for growth, doubling time, product profile, and physiological group.

Table 1: Examples of CO utilizing species and their physiological characteristics.

Species	Physiological Characterization	T (°C)	pH	t _d (h)	Products
<i>Acetobacterium woodii</i>	Acetogenic	30	6.8	13	Acetate
<i>Butyribacterium metholytrophicum</i>	Acetogenic	37	6	12-20	Acetate, ethanol, butyrate, butanol
<i>Clostridium autoethanogenum</i>	Acetogenic	37	5.8-6.0	nr	Acetate, ethanol
<i>Clostridium carboxidivorans</i>	Acetogenic	38	6.2	6.25	Acetate, ethanol, butyrate, butanol
<i>Clostridium ljungdahlii</i>	Acetogenic	37	6	3.8	Acetate, ethanol
<i>Eubacterium limosum</i>	Acetogenic	38-39	7.0-7.2	7	Acetate
<i>Oxobacter pfennigii</i>	Acetogenic	36-38	7.3	13.9	Acetate, n-butyrate
<i>Peptostreptococcus productus</i>	Acetogenic	37	7	1.5	Acetate
<i>Rhodospseudomonas palustris P4</i>	Hydrogenogenic, Phototroph	30	nr	23	H ₂
<i>Rhodospirillum rubrum</i>	Hydrogenogenic, Phototroph	30	6.8	8.4	H ₂
<i>Rubrivivax gelatinosus</i>	Hydrogenogenic, Phototroph	34	6.7-6.9	6.7	H ₂
<i>Citrobacter</i> sp Y19	Hydrogenogenic, Facultative Anaerobe	30-40	5.5-7.5	8.3	H ₂
<i>Methanosarcina acetivorans</i> C2A	Methanogenic	37	7	24	Acetate, formate, CH ₄
<i>Methanosarcina barkeri</i>	Methanogenic	37	7.4	65	CH ₄ , CO ₂
<i>Desulfosporosinus orientis</i>	Sulfate reducing bacteria	35	7	nr	H ₂ S, CO ₂
<i>Desulfovibrio desulfuricans</i>	Sulfate reducing bacteria	37	nr	nr	H ₂ , CO ₂ , H ₂ S
<i>Desulfovibrio vulgaris</i>	Sulfate reducing bacteria	37	nr	nr	H ₂ , CO ₂ , H ₂ S

Mesophilic Bacteria

Thermophilic Bacteria	<i>Species</i>	Physiological Characterization	T (°C)	pH	t_d(h)	Products
	<i>Moorella thermoacetica</i>	Acetogenic	55	6.5-6.8	10	Acetate
	<i>Moorella thermoautotrophica</i>	Acetogenic	58	6.1	7	Acetate
	<i>Carboxydibrachium pacificus</i>	Hydrogenogenic, Obligate Anearobe	70	6.8-7.1	7.1	H ₂
	<i>Carboxydocella thermoautotrophica</i>	Hydrogenogenic, Obligate Anearobe	58	7	1.1	H ₂
	<i>Carboxydotherrnus hydrogenoformans</i>	Hydrogenogenic, Obligate Anearobe	70-72	6.8-7.0	2	H ₂
	<i>Thermincola carboxydiphila</i>	Hydrogenogenic, Obligate Anearobe	55	8	1.3	H ₂
	<i>Thermolithobacter carboxydivorans</i>	Hydrogenogenic, Obligate Anearobe	70	7	8.3	H ₂
	<i>Thermosinus carboxydivorans</i>	Hydrogenogenic, Obligate Anearobe	60	6.8-7.0	1.2	H ₂
	<i>Methanothermobacter thermoautotrophicus</i>	Methanogenic	65	7.4	140	CH ₄ , CO ₂
	<i>Desulfotomaculum carboxydivorans</i>	Sulfate reducing bacteria	55	7	1.7	H ₂ , H ₂ S
	<i>Desulfotomaculum kuznetsovil</i>	Sulfate reducing bacteria	60	7	nr	Acetate, H ₂ S
	<i>Desulfotomaculum nigrificans</i>	Sulfate reducing bacteria	55	7	nr	H ₂ S, CO ₂
	<i>Desulfotomaculum thermobenzoicum subsp. thermosyntrophicum</i>	Sulfate reducing bacteria	55	7	nr	Acetate, H ₂ S

Adapted from Henstra et al., *Curr. Opin. Biotechnol.* 18:200-206 (2007); Sipma et al., *Crit. Rev. Biotechnol.* 26:41-65 (2006).

One type of organism for consideration of utilizing syngas is thermophilic acetogens due to their ability to tolerate temperatures as high as 72°C, which would reduce contamination issues and lower the heating cost associated with separating a product such as butanol via distillation.

5 However, alcohol production from synthesis gas has yet to be demonstrated in thermophiles and their primary products are hydrogen, acetate, and/or H₂S. The doubling times of the acetogenic thermophiles were also longer than for mesophilic acetogens. Thus, initial studies are focused on mesophilic acetogenes for the production of a desired product such as butanol as these organisms have the fastest doubling times and have been shown to produce alcohols from syngas. Initial
10 characterizations are performed on *Clostridium ljungdahlii* and *Clostridium carboxidivorans*. Of all syngas-utilizing organisms, *C. ljungdahlii* has a substantial body of knowledge relating to its metabolic capabilities and optimum fermentation conditions. *C. carboxidivorans* has been shown to naturally produce small quantities of butanol during growth on syngas (Henstra et al., *Curr. Opin. Biotechnol.* 18:200-206 (2007)).

15 The metabolic pathways of some exemplary syngas utilizing organisms are known. Two exemplary pathways utilizing syngas are shown in Figures 1 and 2.

Acetogens, such as *C. ljungdahlii* and *C. carboxidivorans*, can grow on a number of carbon sources ranging from hexose sugars to carbon monoxide. Hexoses, such as glucose, are metabolized first via Embden-Meyerhof-Parnas (EMP) glycolysis to pyruvate, which is then
20 converted to acetyl-CoA via pyruvate:ferredoxin oxidoreductase. Acetyl-CoA can be used to build biomass precursors or can be converted to acetate, which produces energy via acetate kinase and phosphotransacetylase. The overall conversion of glucose to acetate, energy, and reducing equivalents is:



25 Acetogens extract even more energy out of the glucose to acetate conversion while also maintaining redox balance by further converting the CO₂ to acetate via the Wood-Ljungdahl pathway

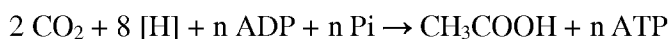

The coefficient n in the above equation signify that this conversion is an energy generating endeavor, as many acetogens can grow in the presence of CO_2 via the Wood-Ljungdahl pathway even in the absence of glucose as long as hydrogen is present to supply the necessary reducing equivalents.



The Wood-Ljungdahl pathway, illustrated in Figure 3, is coupled to the creation of Na^+ or H^+ ion gradients that can generate ATP via an Na^+ - or H^+ - dependant ATP synthase, respectively (Muller, *Appl. Environ. Microbiol.* 69:6345-6353 (2003)). Based on these known transformations, acetogens also have the capacity to utilize CO as the sole carbon and energy source. Specifically, CO can be oxidized to produce reducing equivalents and CO_2 , or directly assimilated into acetyl-CoA which is subsequently converted to either biomass or acetate.



Even higher acetate yields, however, can be attained when enough hydrogen is present to satisfy the requirement for reducing equivalents.



Following from Figure 3, the production of acetate via acetyl-CoA generates one ATP molecule, whereas the production of ethanol from acetyl-CoA does not and requires two reducing equivalents. Thus ethanol production from syngas is not expected to generate sufficient energy for cell growth in the absence of acetate production. However, under certain conditions, *Clostridium ljungdahlii* produces mostly ethanol from synthesis gas (Klasson et al., *Fuel* 72:1673-1678 (1993)), indicating that some combination of the following pathways



25 does indeed generate enough energy to support cell growth. Hydrogenic bacteria such as *R. rubrum* can also generate energy from the conversion of CO and water to hydrogen (see Figure 3) (Sipma et al., *Crit. Rev. Biotechnol.* 26:41-65 (2006)). The key mechanism is the coordinated

action of an energy converting hydrogenase (ECH) and CO dehydrogenase. The CO dehydrogenase supplies electrons from CO which are then used to reduce protons to H₂ by ECH, whose activity is coupled to energy-generating proton translocation. The net result is the generation of energy via the water-gas shift reaction.

5 The product profile from syngas fermentations is determined by the choice of organism and experimental conditions. For example, *Clostridium ljungdahlii* produces a mixture of ethanol and acetate (Klasson et al., *Fuel* 72:1673-1678 (1993); Gaddy and Clausen, U.S. Patent No. 5,173,429) while *Clostridium carboxidivorans* produces a mixture of ethanol, acetate, butanol, and butyrate (Liou et al., *Int. J. Syst. Evol. Microbiol.* 55(Pt 5):2085-2091 (2005)). Acetate and
10 biomass concentrations as high as 26.8 g/L and 12.4 g/L, respectively, together with ethanol concentrations below 1 g/L have been reported with *C. ljungdahlii* (Gaddy, U.S. Patent Nos. 5,807,722, 6,136,577 and 6,340,581). This product profile can be shifted, however, towards increased ethanol formation by traditional means of increasing solvent formation over acid production in *Clostridia*, for example, using nutrient limitation, media alteration, lower pH,
15 reducing agent addition, and the like. Product profile sensitivity to a number of conditions, for example, calcium pantothenate limitation, cobalt limitation, H₂ oversupply, CO oversupply, acetate conditioning, and the like, has been described (Gaddy et al., U.S. Patent No. 7,285,402). Ethanol, acetate, and cell concentrations of 33.0 g/L, 4.0 g/L, and 2.7 g/L, respectively, were demonstrated with *C. ljungdahlii* strain C-01 without cell recycle under conditions optimized for
20 ethanol production. Maximum ethanol productivities ranged from 21 g/L/day without cell recycle to 39 g/L/day with cell recycle.

Sensitivity of syngas fermentations to inhibitors can also be determined. Fewer efforts to optimize the fermentation conditions of *C. carboxidivorans* (Liou et al., *Int. J. Syst. Evol. Microbiol.* 55(Pt 5):2085-2091 (2005)) for the generation of a particular product have been
25 reported. However, a number of recent studies have been aimed at the inhibition of *C. carboxidivorans* growth by syngas inhibitors. Specifically, inhibitors present in the biomass-generated producer gas stopped *C. carboxidivorans* growth and H₂ utilization, although growth could be recovered when "clean" bottled gasses consisting of only CO, CO₂, N₂, and H₂ were introduced (Datar et al., *Biotechnol. Bioeng.* 86:587-594 (2004)). Passing the gas through a
30 0.025 µm filter cleaned it well enough to allow cell growth, although H₂ utilization was still blocked (Ahmed et al., *Biomass Bioenergy* 30:665-672 (2006)). A scanning electron microscope analysis of the filter indicated that tar particulates, and not ash, was the likely culprit

leading to cell dormancy. Potential tar species were identified as benzene, toluene, ethylbenzene, p-xylene, o-xylene, and naphthalene. Cells were able to adapt to the tars present following the 0.2 μm filter within 10-15 days. The fact that H_2 utilization ceased regardless of filter size indicated that a non-filtered component was inhibiting the hydrogenase enzyme. This compound was later identified as nitric oxide. NO inhibits hydrogenase at ≥ 60 ppm levels (Ahmed and Lewis, *Biotechnol. Bioeng.* 97:1080-1086 (2007)). Similar studies can be performed to determine appropriate conditions for the utilization of syngas in a particular organism to produce a desired product.

In an exemplary experiment, it is assumed that synthesis gas exiting the gasifier is passed through a cyclone, a condensation tower, a scrubber, and a 0.2 μm filter, similar to the system described previously for switchgrass gasification (Datar et al., *Biotechnol. Bioeng.* 86:587-594 (2004); Ahmed et al., *Biomass Bioenergy* 30:665-672 (2006)). Oxygen blown gasification, as opposed to air blown, is used so that NO levels under 40 ppm can be achieved, as suggested previously (Ahmed and Lewis, *Biotechnol. Bioeng.* 97:1080-1086 (2007)). Furthermore, studies with *C. ljungdahlii* revealed that H_2S levels under 2.7% are not inhibitory (Klasson et al., *Fuel* 72:1673-1678 (1993)), even when the cells are not acclimated beforehand, and levels are expected to be below that level with syngas obtained from biomass or even coal gasification. In addition, tolerance to tar particulates can be achieved through evolution or adaptation (Ahmed et al., *Biomass Bioenergy* 30:665-67. (2006)).

20

EXAMPLE II Design and Modeling of Microbial Strains for Utilization of Syngas

This example describes the design of exemplary microbial strains for the production of a desired product from syngas.

Initial studies utilize genome-scale models of *C. ljungdahlii*, *C. carboxidivorans*, and *R. rubrum* for the design of microbial strains capable of utilizing syngas as a carbon source. Metabolic models and simulation algorithms are used to develop strains that utilize syngas. Genomic sequences of desired microorganisms are utilized, along with sequences from closely related species, to construct genome-scale metabolic models of the target organisms. To facilitate this process, Genomatica has developed a comprehensive methodology to automatically build a first draft of a metabolic network based on an exhaustive sequence comparison with our existing high

quality manually built metabolic models. Next, the automatically generated gene-protein-reaction (GPR) assignments, see Figure 2, are checked manually and detailed notes are catalogued within SimPheny™, Genomatica's proprietary model construction and simulation platform, to ensure that they are as transparent as possible. For the production of butanol as an exemplary product, enzymes in the butanol pathway are expressed in those organisms that do not produce butanol naturally, for example, *C. ljungdahlii* and *R. rubrum*.

The metabolic models are interrogated using a constraint-based modeling approach (Schilling et al., *Biotechnol. Prog.* 15:288-295 (1999); Edwards et al., *Environ. Microbiol.* 4:133-40 (2002); Varma and Palsson, *Biotechnol.* 12:994-998 (1994); Patil et al., *Curr. Opin. Biotechnol.* 15:64-69 (2004)). Briefly, rather than attempting to calculate and predict exactly what an organism does, the constraint-based approach narrows the range of possible phenotypes that an organism can display based on the successive imposition of governing physico-chemical constraints, for example, stoichiometric, thermodynamic, capacity, and regulatory (Price et al., *Trends Biotechnol.* 21:162-169 (2003); Price et al., *Nat. Rev. Microbiol.* 2:886-897 (2004)). Thus, instead of calculating an exact phenotypic "solution," that is exactly how an organism will behave under given genetic and environmental conditions, it can determine the feasible set of phenotypic solutions in which the organism can operate. In general, genome-scale constraint-based models have been shown to be useful in predicting several physiological properties such as growth and by-product secretion patterns (Edwards and Palsson, *Proc. Natl. Acad. Sci. USA* 97:5528-5533 (2000); Varma et al., *Appl. Environ. Microbiol.* 59:2465-2473 (1993); Varma and Palsson, *Appl Environ Microbiol.* 60:3724-3731 (1994); Edwards et al., *Nat. Biotechnol.* 19:125-130 (2001)), determining the range of substrate utilization (Edwards and Palsson, *supra*, 2000), determining the minimal media for growth (Schilling et al., *J Bacteriol.* 184:4582-4593 (2002)), predicting the outcome of adaptive evolution (Ibarra et al., *Nature* 420:186-189 (2002)), calculating theoretical product yields (Varma et al., *Biotechnol. Bioengineer.* 42:59-73 (1993)), predicting knockout phenotypes (Edwards and Palsson, *BMC Bioinformatics* 1:1 (2000); Segre et al., *Proc. Natl. Acad. Sci. USA* 99:15112-15117 (2002); Shlomi et al., *Proc. Natl. Acad. Sci. USA* 102:7695-7700 (2005)) and comparing metabolic capabilities of different organisms (Forster et al., *Genome Res.* 13:244-253 (2003)). Based on these predictive capabilities, the models are used to characterize the metabolic behavior of industrial microbes under laboratory and production scale fermentation conditions. Constraint-based approaches have matured to the point where they are commonly applied to pinpoint successful genetic manipulations aimed at

improving strain performance (Bro et al., *Metab. Eng.* 8:102-111 (2006); Alper et al., *Nat. Biotechnol.* 23:612-616 (2005); Alper et al., *Metab. Eng.* 7:155-164 (2005); Fong et al., *Biotechnol. Bioeng.* 91:643-648 (2005); Park et al., *Proc. Natl. Acad. Sci. USA* 104:7797-7802 (2007)). Characteristics are continued to be monitored in order to implement further

5 optimization of conditions.

Additional optimization of organisms can be performed by determining gene knockouts to enhance for production of a desired product, including growth-coupled production of a desired product such as butanol (see Example V). *C. ljundahlii* currently can convert mixtures of CO, CO₂, and H₂ to acetate and ethanol, while *C. carboxidivorans* produces a mixture of acetate, ethanol, butyrate, and butanol. *R. rubrum* does not produce alcohols naturally, but has been

10 shown to accumulate high levels of poly- β -hydroxyalkanoates (PHAs). Modeling analysis allows predictions of the effects on cell growth of shifting the metabolism of a biocatalyst organism towards more efficient production of a desired product such as butanol. The modeling also points at metabolic manipulations aimed at driving the metabolic flux through a desired

15 production pathway, for example, the production of butanol. One modeling method is the bilevel optimization approach, OptKnock (Burgard et al., *Biotechnol. Bioengineer.* 84:647-657 (2003)), which is applied to select gene knockouts that collectively result in the growth-coupled production of a desired product such as butanol. Strains designed with a gene knockout strategy are forced, due to network stoichiometry, to produce high levels of a desired product such as

20 butanol for efficient growth, because all other growth options have been removed. Such strains are self-optimizing and stable. Accordingly, they typically maintain or improve upon production levels even in the face of strong growth selective pressures, making them amenable to batch or continuous bioprocessing and also evolutionary engineering.

Several candidate strain are designed and optimization of production conditions are performed.

25 Fermentation conditions are tested in triplicate, alongside control fermentations using the original process parameters. Using data from test fermentations, simulations can be performed to assess changes in metabolism that result from process changes and compared to predictions. If productivity significantly falls short of that anticipated, further simulations are performed using this new knowledge for a second iteration of the design process in order to optimize

30 strains.

EXAMPLE III

Development of Genetic Tools for Target Organisms

5 This example describes the development of tools for genetic manipulation and engineering of target organisms.

Genetic systems are developed in candidate strains for utilization of syngas. In particular, genetic systems are developed for *C. ljungdahlii* and *C. carboxidivorans*. Genetic transformations are also tested in *Rhodospirillum rubrum*. Antibiotic resistance is tested to determine potential markers for selection of desired genetic elements. For example, many 10 *Clostridia* are sensitive to erythromycin and chloramphenicol. DNA transfer methods are developed using well known methods, including but not limited to electroporation, conjugation or ultrasound transformation. Additional testing is performed on several expression vectors of gram positive bacteria, particularly the vectors used in *C. acetobutylicum*, to determine their effectiveness for expression of desired genetic elements in *C. ljungdahlii* and/or *C.* 15 *carboxidivorans*. Additional vectors can be developed by replacing the promoter of the vectors with a native *C. ljungdahlii* or *C. carboxidivorans* promoter. In addition, several suicide plasmids, including those of *C. acetobutylicum* and *C. cellulolyticum*, are tested for genetic manipulation. The knockdown technique of antisense RNA inhibition developed for other *Clostridia* are also tested.

20 The transformation, expression and antisense RNA inhibition tools are available for mesophilic species *Clostridium cellulolyticum* and *Clostridium acetobutylicum*. *C. cellulolyticum* is a model system for cellulose degradation (Desvaux, *FEMS Microbiol Rev.* 741-764 (2005)), whereas *C. acetobutylicum* has been intensively characterized for its ability to produce solvents such as butanol (Durre, *Biotechnol. J.* 2:1525-1534 (2007)). Notably, both species are capable of 25 producing ethanol and hydrogen as an end product. Therefore, knowledge from these two strains is instructive for other ethanol- and/or hydrogen-producing *Clostridia* species. Studies of targeted mutagenesis in *C. cellulolyticum* have been initiated and can be similarly used on other candidate organisms.

The results of these studies allow for phenotypic characterization of the mutants generated as 30 well as allow genetic engineering of *C. ljungdahlii* and/or *C. carboxidivorans*. Additional optimization is performed, as needed, to develop genetic systems by varying methods, plasmids

and conditions to achieve an optimized result (Lynd et al., *Microbiol. Mol. Biol. Rev.* 66:506-577 (2002)).

In more detail, profiling the antibiotic resistance capacities of *C. ljungdahlii* and *C. carboxidivorans* is performed. An important step in developing genetic systems is to determine the native antibiotic resistance characteristics of the target strains. Erythromycin and chloramphenicol are two antibiotics with resistance markers that have been shown to be functional on plasmids in *C. acetobutylicum* and *C. cellulolyticum* (Kashket and Cao, *Appl. Environ. Microbiol.* 59:4198-4202 (1993); Green and Bennett, *Biotechnol. Bioeng.* 58:215-221 (1998)). However, they are usually not available for common suicide plasmids, which instead often contain antibiotic markers of ampicillin, gentamycin, rifampicin, kanamycin and tetracycline. In order to determine antibiotic sensitivity, *C. ljungdahlii* and *C. carboxidivorans* are grown in defined medium in an anaerobic chamber (Ahmed and Lewis, *Biotechnol. Bioeng.* 97:1080-1086 (2007); Younesi et al., *Bioresour. Technol.* June 18, 2007). Common antibiotics as indicated above are added at gradient concentrations from 1 µg/ml to 500 µg/ml. An instrument such as a Type FP-1100-C Bioscreen C machine (Thermo Labsystems; Waltham MA) is used to control the growth temperature at 37°C and automatically measure the optical density of cell growth at different intervals. All of the physiological studies are performed in replicate, for example, triplicates, so that the average and standard deviation can be calculated. This growth data indicates the sensitivity of *C. ljungdahlii* and *C. carboxidivorans* to the antibiotics being tested. The antibiotics that inhibit growth of the strain are used in further studies.

In more detail, DNA transfer methods and gene expression systems are developed to provide simple and efficient DNA delivery methods for genetic engineering. Methods for bacterial DNA transfer include conjugation, electroporation, chemical transformation, transduction and ultrasound transformation. Among them, electroporation and conjugation have been previously established in several *Clostridial* species (Jennert et al., *Microbiol.* 146:3071-3080 (2000); Tardif et al., *J. Ind. Microbiol. Biotechnol.* 27:271-274 (2001); Tyurin et al., *J. Appl. Microbiol.* 88:220-227 (2000); Tyurin et al., *Appl. Environ. Microbiol.* 70:883-890 (2004)). Ultrasound transformation is a convenient and efficient method that provides high transformation efficiency (>10⁶ CFU/µg DNA) for gram negative bacteria (Song et al., *Nucl. Acids Res.* 35:e129 (2007)) and can be tested in gram positive bacteria.

Electroporation, ultrasound transformation, and conjugation are tested for *C. ljungdahlii* and *C. carboxidivorans* transformation efficiencies. A variety of plasmids from gram positive bacteria with different replicons, for example, pIP404, pAM β 1 and pIM13, are tested. If needed, subcloning is employed to replace the antibiotic resistance cassettes of existing plasmids with the suitable ones based on antibiotic resistance testing. Standard molecular subcloning techniques, including restriction enzyme digestion, ligation by T4 ligase and *E. coli* transformation, are used for engineering of the plasmids (Sambrook et al., *Molecular Cloning: A Laboratory Manual* Cold Spring Harbor Laboratory Press (1989)). As required for many other *Clostridial* species, these plasmids are methylated prior to DNA delivery to protect them from degradation by the host bacteria. For electroporation and conjugation, existing protocols of *C. cellulolyticum* and *C. acetobutylicum* are tested first. Parameters such as electroporation setup, recovery time, and concentration of Ca²⁺ and Mg²⁺ in the electroporation buffer are varied to optimize the transformation efficiency. For ultrasound transformation, experiments are conducted under conditions of low frequency ultrasound, for example, 40 kHz, and extended recovery time as previously described (Song et al., *supra*, 2007)).

Once an efficient DNA transfer protocol is established for certain plasmids, the plasmids are engineered to incorporate a native *C. ljungdahlii* or *C. carboxidivorans* promoter followed by a multiple cloning site to generate expression vectors. It is expected that the existing expression vectors of *C. acetobutylicum*, such as pSOS95 and pIMP1, can likely work in *C. ljungdahlii* or *C. carboxidivorans* without changes of the promoter, so these plasmids are used for initial testing.

To develop gene disruption methods, several suicide plasmids such as pKNOCK, pDS3.0, pSPUC and pBluescript SKII are screened for suitability as suicide plasmids for *C. ljungdahlii* and/or *C. carboxidivorans*. As discussed above, if the results either existing antibiotic resistance cassettes are used or are replaced with suitable antibiotic resistance cassettes. A DNA fragment of a selected target gene is subcloned into appropriate suicide plasmids. The genes selected as the initial targets are those encoding the alcohol dehydrogenases responsible for ethanol production. These genes were selected because they lead to byproduct formation, are likely to be identified as targets for disruption for butanol-producing strains, and provide for an easy screen by analyzing ethanol in the fermentation broth. If deletion of an alcohol dehydrogenase in *C. carboxidivorans* lowers butanol production in addition to lowering ethanol production due to the broad substrate specificity of these enzymes, an alcohol dehydrogenase which favors butanol

formation over ethanol formation, such as the adhE2 from *C. acetobutylicum* (Atsumi et al., *Metab. Eng.* Sep 14, 2007), can be cloned along with the other butanol pathway genes to construct a butanol pathway.

The engineered suicide plasmids are methylated and transferred into *C. ljungdahlii* and *C.*
5 *carboxidivorans*. Colonies are selected on solid medium containing the appropriate antibiotics. PCR amplification and subsequent sequencing of the disrupted genomic region, southern blot, and physiological studies are employed to verify the correct disruption of the targeted gene(s) in the genome. The expression systems can also be used as an alternative to gene disruption to express the antisense RNA of the target gene, which will inhibit but not completely abolish its
10 gene expression. Therefore, the antisense RNA system serves as a convenient approach of gene knock-down of a desired gene.

EXAMPLE IV **Genetic Assessment of *Rhodospirillum rubrum***

15 This example describes development of genetic tools for *Rhodospirillum rubrum* as an organism for utilization of syngas.

Rhodospirillum rubrum is a Gram negative, purple non-sulfur bacterium which oxidizes CO under anaerobic conditions (Kerby et al., *J. Bacteriol.* 177:2241-2244 (1995); Kerby et al., *J. Bacteriol.* 174:5284-5294 (1992)). *R. rubrum* possess a Ni-Fe-S CO dehydrogenase (CODH)
20 that catalyzes the oxidation of CO, which is coupled to the formation of hydrogen (Ensign and Ludden, *J. Biol. Chem.* 1991. 266:18395-18403 (1991)). Given its CO oxidation capacity and ability to fix CO₂, *R. rubrum* is capable of efficient growth on syngas in the dark (Do et al., *Biotechnol. Bioeng.* 97:279-286 (2007)). In addition, it has been shown that during growth on syngas, up to 34% of the total cellular carbon is stored in the form of poly- β -hydroxyalkanoates
25 (PHA) that consist primarily of β -hydroxybutyrate (PHB). The ability of *R. rubrum* to efficiently direct cellular carbon to form reduced 4-carbon compounds make it an attractive platform for engineering production of a desired product such as 1-butanol. In addition, a genetic system has been established for *R. rubrum*, and a wide range of cloning vectors including the broad-host range RK2 derivatives are available (Saegesser et al., *FEMS Microbiol. Lett.*
30 95:7-12 (1992)). Another attractive aspect of utilizing *R. rubrum* is that there is considerable overlap in the pathways leading to PHB and 1-butanol synthesis (Figure 5). Since PHB synthesis

has been studied for its use as a biodegradable plastic, considerable information is available regarding PHB pathway regulation and over expression (Anderson and Dawes, *Microbiol. Rev.* 54:450-472 (1990)). In parallel to establishing the genetic tools necessary for manipulating the *Clostridial* strains as discussed above, a synthetic operon consisting of several genes from
5 *Clostridium acetobutylicum* that form the 1-butanol synthesis pathway is developed as well.

Since *R. rubrum* has been sequenced and has a tractable genetic system (Saegesser et al., *FEMS Microbiol. Lett.* 95:7-12 (1992)), it is expected that targeted deletions can be made in selected loci. Broad-host range, site-specific gene excision systems are available which allow markerless deletions to be generated (Hoang et al., *Gene* 212:77-86 (1998)). Therefore, it will be possible to
10 generate multiple knockouts in a single strain without relying on multiple antibiotic selections. This method can be tested by deleting the PHB synthase gene, which is the terminal step in PHB synthesis (Hustede et al., *FEMS Microbiol. Lett.* 72:285-290 (1992)). This is chosen because PHB synthesis will likely compete with the proposed butanol pathway for 4-carbon precursors and reducing equivalents (Figure 5). Successful deletion of the equivalent gene in
15 *Methylobacterium extorquens*, a gram negative bacterium also known to accumulate over 30% by weight PHB, has been reported with no deleterious effect on growth (Korotkova and Lidstrom, *J. Bacteriol.* 183:1038-1046 (2001)).

EXAMPLE V

Engineering Microorganisms for Production of Butanol from Syngas

20

This example describes engineering microorganisms for production of butanol formation from syngas.

In initial studies, *Clostridial* strains, in particular, *C. carboxidivorans*, are used to engineer
25 utilization of syngas for production of and tolerance to butanol. *C. carboxidivorans* has been shown to produce butanol from synthesis gas (Liou et al., *Int. J. Syst. Evol. Microbiol.* 55(Pt 5):2085-2091 (2005)). *C. carboxidivorans* is engineered to increase syngas utilization efficiency, increase the efficiency of butanol production from syngas as an exemplary desired product, and to increase product tolerance so that higher yields of a desired product can be
30 obtained.

Preliminary metabolic network analysis has revealed that the theoretical conversion of lignocellulosic-derived syngas to butanol compares favorably to sugar fermentation.

Syngas to Butanol:

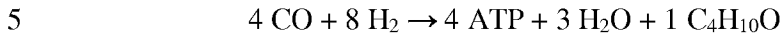

Sugar to Butanol:

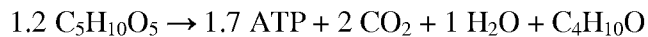
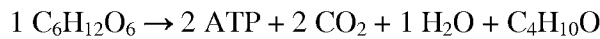

10 Given that biomass gasification can optimally provide a 1:1 ratio of CO to H₂, the production of one mole of butanol will require 12 moles of CO + H₂. Importantly, the fermentative conversion of syngas to butanol is an energy-generating endeavor, therefore supporting cell growth at high product yields. Furthermore, initial calculations reveal the substrate cost to be cheaper than the equivalent amount of sugar that would be required.

15 As discussed above, models and genetic tools are utilized to design strains that facilitate the production of butanol or other desired products as an obligatory product of cell growth. In other words, the cell is engineered so that butanol is a necessary electron sink during growth on CO. The strains are constructed, which may have a combination of gene knockouts and overexpression of appropriate enzymes, and can be evolved for improved production and
20 tolerance of growth conditions.

For construction of *Clostridial* strains producing butanol, genome analysis as discussed above is used to identify biological pathways necessary for establishing and/or improving butanol production in *C. ljungdahlii* and *C. carboxidivorans*. Additional improvement in butanol production can be achieved by increasing expression of syngas utilization pathway and/or
25 butanol production pathway proteins and enzymes. To express the gene(s) in the targeted biological pathway, gene expression vectors developed as discussed above are used. If there is more than one gene, the genes are PCR amplified and cloned into an expression vector as a

synthetic operon. The resulting expression plasmid is transferred into *C. ljungdahlii* and *C. carboxidivorans*. Northern blot and/or real time PCR, or other suitable techniques, are used to examine gene expression at the transcriptional level.

To improve butanol production, it is likely that endogenous gene(s) of *C. ljungdahlii* and *C. carboxidivorans* will be inactivated to reroute the redox potential toward butanol production. To this end, an internal DNA fragment of a targeted gene will be PCR amplified and cloned into a suicide plasmid. Then the plasmid is transferred into *C. ljungdahlii* and *C. carboxidivorans*, resulting in disruption of the target gene by single crossover recombination. The correct disruption is confirmed by sequencing of the PCR product amplified from the disrupted genomic locus and/or Southern blot, or using other suitable analytical techniques. If there is more than one targeted gene, the suicide plasmids are engineered to change antibiotic marker so that multiple gene knockouts can be generated in a single strain. It is expected that up to 3 to 6 gene deletions may be beneficial in optimizing butanol production.

For genetic engineering of *Rhodospirillum rubrum* for butanol production, a synthetic operon is developed consisting of several genes that form the butanol synthesis pathway in *Clostridium acetobutylicum*. A similar approach for allowing butanol production in *E. coli* was recently reported, proving that heterologous expression of the pathway in Gram negative organisms is possible (Atsumi et al., *Metab. Eng.* Sep 14, 2007). The necessary genes for butanol production in *R. rubrum* can be expressed on a broad-host-range expression vector. Expression can be controlled using an inducible promoter such as the tac promoter. The synthetic, 4-gene operon is constructed using a fusion PCR technique and will include genes for crotonase, butyryl-CoA dehydrogenase, electron transfer flavoprotein, and aldehyde/alcohol dehydrogenase activities. Fusion/assembly PCR techniques have been used to construct synthetic operons for expression in heterologous hosts (Craney et al., *Nucl. Acids Res.* 35:e46 (2007); Hill et al., *Mol. Gen. Genet.* 226:41-48 (1991)). The butanol operon is transformed into both the wild-type and PHB synthesis deficient *R. rubrum* strains, and tested as described below. It is also possible that more than one gene is desirable to be targeted for removal based on modeling studies. These deletions can be implemented using the markerless method, as discussed above.

As intermediate strains are being constructed, they are tested physiologically to evaluate progress towards butanol production, as well as the ability to sustain robust growth and reduced byproduct formation. Initial screening for growth and butanol production is performed initially in 1 mL.

microreactors (such as MicroReactor Technologies, Inc.; Mountain View, CA). Configurations such as 24-well plates can be controlled for pH, temperature, and gas composition. As a next step, serum bottles are vigorously shaken in temperature and gas composition controlled incubators. This allows sampling and analysis of the gas headspace as well as the liquid phase.

5 Products such as butanol, ethanol, and organic acids can be analyzed by gas chromatography (GC/MS) or HPLC using routine procedures. H₂, CO, and CO₂ in the headspace will be analyzed by GC with Thermal Conductivity Detector (TCD) detection using 15% Ar as an internal standard, as described previously (Najafpour and Younesi, *Enzyme Microb. Technol.* 38:223-228 (2006)). In these experiments, synthetic syngas with 1/1 ratio of H₂ in CO is used. The effect of
10 gas composition is explored during the fermentation optimization.

Initially, strains with one or more deletions is analyzed to compare growth and fermentation profiles relative to wild-type cells. It is possible that growth in multiple deletion strains will be poor without enhanced expression of the butanol pathway. Strains expressing one or more butanol pathway genes, or other targets identified by metabolic modeling, are tested in the wild-
15 type host to assess the ability to enhance flux through the butanol pathway and provide a preliminary assessment of which steps are likely bottlenecks. Different gene orders, and if possible alternate promoters and ribosome binding sites, are tested to optimize the synthetic operon construct. The construct(s) yielding the most positive results are transformed into the host containing the prescribed gene deletions, and tested as described above. Results are
20 compared to model predictions to assess where unforeseen limitations and metabolic bottlenecks may exist.

After genetic engineering manipulations are made, adaptive evolution can be utilized to optimize production in a desired strain. Based on strain design that couples the production of butanol to growth applies selection pressure that favors cells with improved growth rate and/or yield and
25 will lead to higher butanol yield. Adaptive evolution is therefore performed to improve both growth and production characteristics (Fong and Palsson, *Nat. Genet.* 36:1056-1058 (2004); Alper et al., *Science* 314:1565-1568 (2006)). Based on the results, subsequent rounds of modeling and genetic engineering can be utilized to further optimize production. The evolutionary engineering step can be carried out in a device that automatically maintains cells in
30 prolonged exponential growth by the serial passage of batch cultures into fresh medium before the stationary phase is attained. Specifically, when a certain cell density is reached, a fraction of the media with exponentially growing cells is passed from one region to an adjacent region while

fresh media is added for the dilution. By automating optical density measurement and liquid handling, serial transfer can be performed at high rates, thus approaching the efficiency of a chemostat for evolution of cell fitness (Dykhuizen, *Methods Enzymol.* 224:613-631 (1993)). However, in contrast to a chemostat, which maintains cells in a single vessel, this procedure eliminates the possibility of detrimental selection for cells adapted for wall-growth (Chao and Ramsdell, *J. Gen. Microbiol.* 131:1229-1236 (1985); Lynch et al., *Nat. Methods* 4:87-93 (2007)). In addition, this method allows the cells to be maintained in a closed system that ensures strict anaerobic conditions, a requirement for growing the *Clostridia*.

An additional role that adaptive evolution can play is to develop strains that are more tolerant to butanol and impurities such as NO_x and tars. Butanol tolerance levels have not been published for *C. ljungdahlii* and *C. carboxidivorans*, and this is measured for wild-type cells to determine tolerated levels. Wild-type *C. acetobutylicum* has been reported to have a tolerance of approximately 180 mM (1.2% w/v) (Tomas et al., *Appl. Environ. Microbiol.* 69:4951-4965 (2003)) and have been engineered to achieve a tolerance levels as high as 2.1% (Ezeji et al., *Chem. Rec.* 4:305-314 (2004)). Two approaches are currently prevalent to improve the butanol tolerance capacity of *Clostridia*. One involves changing the lipid composition and the fluidity of the membrane via rational genetic modification of lipid content, or by evolution methods such as serial enrichment (Soucaille et al., *Curr. Microbiol.* 14:295-299 (1987)) or random mutagenesis (Jain et al., U.S. Patent No. 5,192,673/1993). However, tolerance is a complex function of multiple factors and is difficult to achieve with directed modification alone. Further, the cells are reported to lyse at high concentrations of butanol (Van Der Westhuizen et al., *Appl. Environ. Microbiol.* 44:1277-1281 (1982)). Therefore, optimization of strains is based on a combination of genetics, evolution, and metabolic modeling. The wild type strains can be evolved adaptively in the presence of successively increasing concentrations of butanol to demonstrate that butanol tolerance in *Clostridium* can be improved through this process. One goal is to optimize cells by evolving the cells to obtain a tolerance of butanol, for example, a concentration as high as 25 g/L. A similar procedure can be performed a similar procedure can be used to evaluate the tolerance of strains to syngas impurities using, for example, NO and aromatic compounds prevalent in tars. Adaptive evolutions for optimization of production and/or tolerance of impurities can be performed sequentially or concurrently. This approach can also be integrated with directed mutation of genes associated with butanol tolerance and membrane fluidity, to optimize tolerance levels suitable for commercial scale production.

An exemplary syngas to butanol process is illustrated in Figure 4. Figure 4 illustrates a block flow diagram for a process of utilizing syngas to produce butanol.

EXAMPLE VI **Development and Optimization of Syngas Fermentation Processes**

5

This example describes the development and optimization of syngas fermentation processes. A laboratory-scale syngas fermentation using authentic syngas is performed to demonstrate and optimize target yields for commercial scale production.

Important process considerations for a syngas fermentation are high biomass concentration and good gas-liquid mass transfer (Bredwell et al., *Biotechnol. Prog.* 15:834-844 (1999)). The solubility of CO in water is somewhat less than that of oxygen. Continuously gas-sparged fermentations can be performed in controlled fermenters with constant off-gas analysis by mass spectrometry and periodic liquid sampling and analysis by GC and HPLC. The liquid phase can function in batch mode. Butanol and byproduct formation is measured as a function of time.

10 Although the final industrial process will likely have continuous liquid flow, batch operation can be utilized to study physiology in the early stages of characterization and optimization. All piping in these systems are glass or metal to maintain anaerobic conditions. The gas sparging is performed with glass frits to decrease bubble size and improve mass transfer. Various sparging rates are tested, ranging from about 0.1 to 1 vvm (vapor volumes per minute). To obtain

15 accurate measurements of gas uptake rates, periodic challenges are performed in which the gas flow is temporarily stopped, and the gas phase composition is monitored as a function of time.

20

Fermentation systems specific for syngas utilization are also developed. Although designs are tested with engineered organisms, testing of fermentation systems can be done in parallel to strain development, using wild-type organisms at first. In order to achieve the overall target

25 productivity, methods of cell retention or recycle are employed. A usual concern about such systems operated continuously is that cells could evolve to non-producing phenotypes. Because the organisms are designed for growth-coupled production of a desired product, the organisms are genetically stable. One method to increase the microbial concentration is to recycle cells via a tangential flow membrane from a sidestream. Repeated batch culture can also be used, as

30 previously described for production of acetate by *Moorella* (Sakai S., Y. Nakashimada, K. Inokuma, M. Kita, H. Okada, and N. Nishio, Acetate and ethanol production from H₂ and CO₂ by

Moorella sp. using a repeated batch culture. *J. Biosci. Bioeng.* 99:252-258 (2005)). Various other methods can also be used (Bredwell et al., *Biotechnol. Prog.* 15:834-844 (1999); Datar et al., *Biotechnol. Bioeng.* 86:587-594 (2004)). Additional optimization can be tested such as overpressure at 1.5 atm to improve mass transfer (Najafpour and Younesi, *Enzyme Microb. Technol.* 38:223-228 (2006)).

Once satisfactory performance is achieved using pure H₂/CO as the feed, synthetic gas mixtures are generated containing inhibitors likely to be present in commercial syngas. For example, a typical impurity profile is 4.5% CH₄, 0.1% C₂H₂, 0.35% C₂H₆, 1.4% C₂H₄, and 150 ppm nitric oxide (Datar et al., *Biotechnol. Bioeng.* 86:587-594 (2004)). Tars, represented by compounds such as benzene, toluene, ethylbenzene, p-xylene, o-xylene, and naphthalene, are added at ppm levels to test for any effect on production. For example, it has been shown that 40 ppm NO is inhibitory to *C. carboxidivorans* (Ahmed and Lewis, *Biotechnol. Bioeng.* 97:1080-1086 (2007)). Cultures are tested in shake-flask cultures before moving to a fermenter. Also, different levels of these potential inhibitory compounds are tested to quantify the effect they have on cell growth. This knowledge is used to develop specifications for syngas purity, which is utilized for scale up studies and production. If any particular component is found to be difficult to decrease or remove from syngas used for scale up, adaptive evolution procedure can be utilized, as discussed above, to adapt cells to tolerate one or more impurities.

EXAMPLE VII

Minimal Gene Sets for Generating Syngas Utilizing Microorganisms

This example describes determination of a minimal gene/protein sets for generation of syngas utilizing microorganisms, particularly in an microorganism that does not naturally utilize syngas to produce a desired product.

In general, microorganisms have the ability to generate tetrahydrofolate, and methyl-tetrahydrofolate (Me-THF) is a common intermediate in biosynthesis, for example, in methionine production. Hence, the Methyl Branch outlined above and shown in Figure 1 is not a unique feature of organisms that utilize syngas. However, the enzymes required for generating Me-THF have been found to be much more active in syngas-utilizing organisms relative to organisms that do not use syngas. In fact, tetrahydrofolate-dependent enzymes from acetogens have 50 to 100X higher specific activities than those from other sources such as *E. coli* and

eukaryotes (Morton et al., *Genetics and Molecular Biology of Anaerobic Bacteria*, M. Sebal, ed., Chapter 28, pp 389-406, Springer-Verlage, New York, NY (1993)). A more appropriate and unique way to define a set of genes/proteins for designing an organism that can utilize syngas is to use the Carbonyl Branch of the pathway (see Figure 2). This branch includes genes for the following six (6) proteins: cobalamide corrinoid/iron-sulfur protein, methyltransferase, carbon monoxide dehydrogenase (CODH), acetyl-CoA synthase (ACS), acetyl-CoA synthase disulfide reductase, and a CO-tolerant hydrogenase. Therefore, these six genes/proteins represent a set of one or more proteins for conferring a syngas utilization pathway capable of producing acetyl-CoA.

10

EXAMPLE VIII Gene Sets for Generating Syngas Utilizing Microorganisms

This example describes exemplary gene sets for generating syngas utilizing microorganisms.

Formate Dehydrogenase. Formate dehydrogenase is a two subunit selenocysteine-containing protein that catalyzes the incorporation of CO₂ into formate in *Moorella thermoacetica* (Andreesen and Ljungdahl, *J.Bacteriol.* 116:867-873 (1973); Li et al., *J.Bacteriol.* 92:405-412 (1966); Yamamoto et al., *J.Biol.Chem.* 258:1826-1832 (1983). The loci, Moth_2312 and Moth_2313, are actually one gene that is responsible for encoding the alpha subunit of formate dehydrogenase while the beta subunit is encoded by Moth_2314 (Pierce et al., *Environ.Microbiol.* (2008)). Another set of genes encoding formate dehydrogenase activity with a propensity for CO₂ reduction is encoded by Sfum_2703 through Sfum_2706 in *Syntrophobacter fumaroxidans* (de Bok et al., *Eur.J.Biochem.* 270:2476-2485 (2003)); Reda et al., *Proc. Natl. Acad. Sci. U.S.A.* 105:10654-10658 (2008)). Similar to their *M. thermoacetica* counterparts, Sfum_2705 and Sfum_2706 are actually one gene. A similar set of genes presumed to carry out the same function are encoded by CHY_0731, CHY_0732, and CHY_0733 in *C. hydrogenoformans* (Wu et al., *PLoS Genet.* 1:e65 (2005)).

<u>Protein</u>	<u>GenBank ID</u>	<u>Organism</u>
Moth_2312	YP_431142	<i>Moorella thermoacetica</i>
Moth_2313	YP_431143	<i>Moorella thermoacetica</i>
Moth_2314	YP_431144	<i>Moorella thermoacetica</i>
Sfum_2703	YP_846816.1	<i>Syntrophobacter fumaroxidans</i>
Sfum_2704	YP_846817.1	<i>Syntrophobacter fumaroxidans</i>
Sfum_2705	YP_846818.1	<i>Syntrophobacter fumaroxidans</i>
Sfum_2706	YP_846819.1	<i>Syntrophobacter fumaroxidans</i>
CHY_0731	YP_359585.1	<i>Carboxydothemus hydrogenoformans</i>
CHY_0732	YP_359586.1	<i>Carboxydothemus hydrogenoformans</i>
CHY_0733	YP_359587.1	<i>Carboxydothemus hydrogenoformans</i>

Formyltetrahydrofolate synthetase. Formyltetrahydrofolate synthetase ligates formate to

tetrahydrofolate at the expense of one ATP. This reaction is catalyzed by the gene product of

- 5 Moth_0109 in *M. thermoacetica* (Lovell et al., *Arch.Microbiol* 149:280-285 (1988); Lovell et al., *Biochemistry* 29:5687-5694 (1990); O'brien et al., *Experientia.Suppl.* 26:249-262 (1976), *FHS* in *Clostridium acidurici* (Whitehead and Rabinowitz, *J.Bacteriol.* 167:205-209(1986); Whitehead and Rabinowitz, *J.Bacteriol.* 170:3255-3261 (1988)), and CHY_2385 in *C. hydrogenoformans* (Wu et al., *PLoS Genet.* 1:e65 (2005)).

10

<u>Protein</u>	<u>GenBank ID</u>	<u>Organism</u>
Moth_0109	YP_428991.1	<i>Moorella thermoacetica</i>
CHY_2385	YP_361182.1	<i>Carboxydothemus hydrogenoformans</i>
FHS	P13419.1	<i>Clostridium acidurici</i>

Methenyltetrahydrofolate cyclohydrolase and methylenetetrahydrofolate dehydrogenase.

In *M. thermoacetica*, *E. coli*, and *C. hydrogenoformans*, methenyltetrahydrofolate

cyclohydrolase and methylenetetrahydrofolate dehydrogenase are carried out by the bi-functional

- 15 gene products of Moth_1516, *folD*, and CHY_1878, respectively (D'Ari and Rabinowitz, *J.Biol.Chem.* 266:23953-23958 (1991); Pierce et al., *Environ.Microbiol* (2008); Wu et al., *PLoS Genet.* 1:e65 (2005)).

<u>Protein</u>	<u>GenBank ID</u>	<u>Organism</u>
Moth_1516	YP_430368.1	<i>Moorella thermoacetica</i>
<i>folD</i>	NP_415062.1	<i>Escherichia coli</i>
CHY_1878	YP_360698.1	<i>Carboxydothemus hydrogenoformans</i>

Methylenetetrahydrofolate reductase. The final step of the methyl branch of the Wood-Ljungdahl pathway is catalyzed by methylenetetrahydrofolate reductase. In *M. thermoacetica*, this enzyme is oxygen-sensitive and contains an iron-sulfur cluster (Clark and Ljungdahl, *J Biol Chem.* 259:10845-10849 (1984)). This enzyme is encoded by *metF* in *E. coli* (Sheppard et al., *J. Bacteriol.* 181:718-725 (1999)) and CHY_1233 in *C. hydrogenoformans* (Wu et al., *PLoS Genet.* 1:e65 (2005)). The *M. thermoacetica* genes, and its *C. hydrogenoformans* counterpart, are located near the CODH/ACS gene cluster, separated by putative hydrogenase and heterodisulfide reductase genes.

10

<u>Protein</u>	<u>GenBank ID</u>	<u>Organism</u>
<i>metF</i>	NP_418376.1	<i>Escherichia coli</i>
CHY_1233	YP_360071.1	<i>Carboxydotherrmus hydrogenoformans</i>

Acetyl-CoA synthase/Carbon monoxide dehydrogenase (ACS/CODH) and related proteins.

ACS/CODH is the central enzyme of the carbonyl branch of the Wood-Ljungdahl pathway. It catalyzes the reversible reduction of carbon dioxide to carbon monoxide and also the synthesis of acetyl-CoA from carbon monoxide, Coenzyme A, and the methyl group from a methylated corrinoid-iron-sulfur protein. The corrinoid-iron-sulfur-protein is methylated by methyltetrahydrofolate via a methyltransferase. Expression of ACS/CODH in a foreign host involves introducing many, if not all, of the following proteins and their corresponding activities.

15

20

25

- Methyltetrahydrofolate:corrinoid protein methyltransferase (AcsE)
- Corrinoid iron-sulfur protein (AcsD)
- Nickel-protein assembly protein (AcsF)
- Ferredoxin (Orf7)
- Acetyl-CoA synthase (AcsB and AcsC)
- Carbon monoxide dehydrogenase (AcsA)
- Nickel-protein assembly protein (CooC)

The genes required for carbon-monoxide dehydrogenase/acetyl-CoA synthase activity typically reside in a limited region of the native genome that may be an extended operon (Morton et al., *J. Biol. Chem.* 266:23824-23828 (1991); Ragsdale, *Crit. Rev. Biochem. Mol. Biol.* 39:165-195 (2004); Roberts et al., *Proc. Natl. Acad. Sci. USA* 86:32-36 (1989)). Each of the genes in this operon from the acetogen, *M. thermoacetica*, has already been cloned and expressed actively in *E. coli* (Lu et al., *J. Biol. Chem.* 268:5605-5614 (1993); Morton et al., *supra*, 1991; Roberts et

30

al., *supra*, 1989)). The protein sequences of these genes can be identified by the following GenBank accession numbers.

	<u>Protein</u>	<u>GenBank ID</u>	<u>Organism</u>
	AcsE	YP_430054	<i>Moorella thermoacetica</i>
5	AcsD	YP_430055	<i>Moorella thermoacetica</i>
	AcsF	YP_430056	<i>Moorella thermoacetica</i>
	Orf7	YP_430057	<i>Moorella thermoacetica</i>
	AcsC	YP_430058	<i>Moorella thermoacetica</i>
	AcsB	YP_430059	<i>Moorella thermoacetica</i>
10	AcsA	YP_430060	<i>Moorella thermoacetica</i>
	CooC	YP_430061	<i>Moorella thermoacetica</i>

The hydrogenogenic bacterium, *Carboxydotherrmus hydrogenoformans*, can utilize carbon monoxide as a growth substrate by means of acetyl-CoA synthase (Wu et al., *PLoS Genet.* 1:e65. (2005)). In strain Z-2901, the acetyl-CoA synthase enzyme complex lacks carbon monoxide dehydrogenase due to a frameshift mutation (We et al., *supra*, 2005), whereas in strain DSM 6008, a functional unframeshifted full-length version of this protein has been purified (Svetlitchnyi et al., *Proc. Natl. Acad. Sci. USA* 101:446-451 (2004)). The protein sequences of the *C. hydrogenoformans* genes from strain Z-2901 can be identified by the following GenBank accession numbers. Sequences for *Carboxydotherrmus hydrogenoformans* DSM 6008 are not currently accessible in publicly available databases but can be readily determined as the sequences become available.

	<u>Protein</u>	<u>GenBank ID</u>	<u>Organism</u>
	AcsE	YP_360065	<i>Carboxydotherrmus hydrogenoformans</i>
	AcsD	YP_360064	<i>Carboxydotherrmus hydrogenoformans</i>
25	AcsF	YP_360063	<i>Carboxydotherrmus hydrogenoformans</i>
	Orf7	YP_360062	<i>Carboxydotherrmus hydrogenoformans</i>
	AcsC	YP_360061	<i>Carboxydotherrmus hydrogenoformans</i>
	AcsB	YP_360060	<i>Carboxydotherrmus hydrogenoformans</i>
	CooC	YP_360059	<i>Carboxydotherrmus hydrogenoformans</i>

30 The methanogenic archaeon, *Methanosarcina acetivorans*, can also grow on carbon monoxide, exhibits acetyl-CoA synthase/carbon monoxide dehydrogenase activity, and produces both acetate and formate (Lessner et al., *Proc. Natl. Acad. Sci. USA* 103:17921-17926 (2006)). This organism contains two sets of genes that encode ACS/CODH activity (Rother and Metcalf, *Proc. Natl. Acad. Sci. USA* 101:16929-16934 (2004)). The protein sequences of both sets of *M. acetivorans* genes can be identified by the following GenBank accession numbers.

	<u>Protein</u>	<u>GenBank ID</u>	<u>Organism</u>
	AcsC	NP_618736	<i>Methanosarcina acetivorans</i>
	AcsD	NP_618735	<i>Methanosarcina acetivorans</i>
	AcsF, CooC	NP_618734	<i>Methanosarcina acetivorans</i>
5	AcsB	NP_618733	<i>Methanosarcina acetivorans</i>
	AcsEps	NP_618732	<i>Methanosarcina acetivorans</i>
	AcsA	NP_618731	<i>Methanosarcina acetivorans</i>
10	AcsC	NP_615961	<i>Methanosarcina acetivorans</i>
	AcsD	NP_615962	<i>Methanosarcina acetivorans</i>
	AcsF, CooC	NP_615963	<i>Methanosarcina acetivorans</i>
	AcsB	NP_615964	<i>Methanosarcina acetivorans</i>
	AcsEps	NP_615965	<i>Methanosarcina acetivorans</i>
	AcsA	NP_615966	<i>Methanosarcina acetivorans</i>

15 The AcsC, AcsD, AcsB, AcsEps, and AcsA proteins are commonly referred to as the gamma, delta, beta, epsilon, and alpha subunits of the methanogenic CODH/ACS. Homologs to the epsilon encoding genes are not present in acetogens such as *M. thermoacetica* or hydrogenogenic bacteria such as *C. hydrogenoformans*. Hypotheses for the existence of two active CODH/ACS operons in *M. acetivorans* include catalytic properties (that is, K_m , V_{max} , k_{cat}) that favor
20 carboxidotrophic or acetoclastic growth or differential gene regulation enabling various stimuli to induce CODH/ACS expression (Rother et al., *Arch. Microbiol.* 188:463-472 (2007)).

In both *M. thermoacetica* and *C. hydrogenoformans*, additional CODH encoding genes are located outside of the ACS/CODH operons. These enzymes provide the ability to extract electrons, or reducing equivalents, from the conversion of carbon monoxide to carbon dioxide,
25 The reducing equivalents are then passed to accepters such as oxidized ferredoxin, NADP+, water, or hydrogen peroxide to form reduced ferredoxin, NADPH, H₂, or water, respectively. In some cases, hydrogenase encoding genes are located adjacent to a CODH. In *Rhodospirillum rubrum*, the encoded CODH/hydrogenase proteins form a membrane-bound enzyme complex that is proposed to be a site where energy, in the form of a proton gradient, is generated from the
30 conversion of CO to CO₂ and H₂ (Fox et al., *J. Bacteriol.* 178:6200-6208 (1996)). The CODH-I of *C. hydrogenoformans* and its adjacent genes have been proposed to catalyze a similar functional role based on their similarity to the *R. rubrum* CODH/hydrogenase gene cluster (Wu et al., *PLoS Genet.* 1:e65 (2005)). The *C. hydrogenoformans* CODH-I was also shown to exhibit intense CO oxidation and CO₂ reduction activities when linked to an electrode (Parkin et al., *J.*
35 *Am. Chem. Soc.* 129:10328-10329 (2007)). The genes encoding the *C. hydrogenoformans* CODH-II and CooF, a neighboring protein, were cloned and sequenced (Gonzalez and Robb,

FEMS Microbiol. Lett. 191:243-247 (2000)). The resulting complex was membrane-bound, although cytoplasmic fractions of CODH-II were shown to catalyze the formation of NADPH suggesting an anabolic role (Svetlitchnyi et al., *J. Bacteriol.* 183:5134-5144 (2001)). The crystal structure of the CODH-II is also available (Dobbek et al., *Science* 293:1281-1285 (2001)). The

5 protein sequences of exemplary CODH and hydrogenase genes can be identified by the following GenBank accession numbers.

	<u>Protein</u>	<u>GenBank ID</u>	<u>Organism</u>
	CODH (putative)	YP_430813	<i>Moorella thermoacetica</i>
10	CODH-I (CooS-I)	YP_360644	<i>Carboxydothemus hydrogenoformans</i>
	CooF	YP_360645	<i>Carboxydothemus hydrogenoformans</i>
	HypA	YP_360646	<i>Carboxydothemus hydrogenoformans</i>
	CooH	YP_360647	<i>Carboxydothemus hydrogenoformans</i>
	CooU	YP_360648	<i>Carboxydothemus hydrogenoformans</i>
15	CooX	YP_360649	<i>Carboxydothemus hydrogenoformans</i>
	CooL	YP_360650	<i>Carboxydothemus hydrogenoformans</i>
	CooK	YP_360651	<i>Carboxydothemus hydrogenoformans</i>
	CooM	YP_360652	<i>Carboxydothemus hydrogenoformans</i>
20	CooM	AAC45116	<i>Rhodospirillum rubrum</i>
	CooK	AAC45117	<i>Rhodospirillum rubrum</i>
	CooL	AAC45118	<i>Rhodospirillum rubrum</i>
	CooX	AAC45119	<i>Rhodospirillum rubrum</i>
	CooU	AAC45120	<i>Rhodospirillum rubrum</i>
25	CooH	AAC45121	<i>Rhodospirillum rubrum</i>
	CooF	AAC45122	<i>Rhodospirillum rubrum</i>
	CODH (CooS)	AAC45123	<i>Rhodospirillum rubrum</i>
	CooC	AAC45124	<i>Rhodospirillum rubrum</i>
	CooT	AAC45125	<i>Rhodospirillum rubrum</i>
30	CooJ	AAC45126	<i>Rhodospirillum rubrum</i>
	CODH-II (CooS-II)	YP_358957	<i>Carboxydothemus hydrogenoformans</i>
	CooF	YP_358958	<i>Carboxydothemus hydrogenoformans</i>

Acetyl-CoA synthase disulfide reductase. In *Moorella thermoacetica*, a set of genes encoding a

35 heterodisulfide reductase (Moth_1194 to Moth_1196) is located directly downstream of the *acs* gene cluster discussed above. In addition, like *M. thermoacetica*, *C. hydrogenoformans* contains a set of genes encoding heterodisulfide reductase directly following *acsE*.

	Protein	GenBank ID	Organism
	HdrC	YP_430053	<i>Moorella thermoacetica</i>
	HdrB	YP_430052	<i>Moorella thermoacetica</i>
	HdrA	YP_430052	<i>Moorella thermoacetica</i>
5	HdrC	YP_360066	<i>Carboxydotherrmus hydrogenoformans</i>
	HdrB	YP_360067	<i>Carboxydotherrmus hydrogenoformans</i>
	HdrA	YP_360068	<i>Carboxydotherrmus hydrogenoformans</i>

Hydrogenase (Hyd). Unlike the redox neutral conversion of CO and methanol to acetyl-CoA or acetate, the production of more highly reduced products such as ethanol, butanol, isobutanol, 10 isopropanol, 1,4-butanediol, succinic acid, fumaric acid, malic acid, 4-hydroxybutyric acid, 3-hydroxypropionic acid, lactic acid, methacrylic acid, adipic acid, and acrylic acid at the highest possible yield requires the extraction of additional reducing equivalents from both CO and H₂ (for example, see ethanol formation in Figure 7). Specifically, reducing equivalents (for example, 2 [H] in Figure 6) are obtained by the conversion of CO and water to CO₂ via carbon 15 monoxide dehydrogenase as described in Example II or directly from the activity of a hydrogen-utilizing hydrogenase which transfers electrons from H₂ to an acceptor such as ferredoxin, flavodoxin, FAD+, NAD+, or NADP+.

Native to *E. coli* and other enteric bacteria are multiple genes encoding up to four hydrogenases (Sawers, *Antonie Van Leeuwenhoek* 66:57-88 (1994); Sawers et al., *J. Bacteriol.* 164:1324-1331 20 (1985); Sawers and Boxer, *Eur. J. Biochem.* 156:265-275 (1986); Sawers et al., *J. Bacteriol.* 168:398-404 (1986)). Given the multiplicity of enzyme activities, it is possible that *E. coli* or another host organism can provide sufficient hydrogenase activity to split incoming molecular hydrogen and reduce the corresponding acceptor. Among the endogenous hydrogen-lyase enzymes of *E. coli* are hydrogenase 3, a membrane-bound enzyme complex using ferredoxin as 25 an acceptor, and hydrogenase 4, which also uses a ferredoxin acceptor. Hydrogenase 3 and 4 are encoded by the *hyc* and *hyf* gene clusters, respectively. Hydrogenase activity in *E. coli* is also dependent upon the expression of the *hyp* genes whose corresponding proteins are involved in the assembly of the hydrogenase complexes (Jacobi et al., *Arch. Microbiol.* 158:444-451 (1992); Rangarajan et al., *J. Bacteriol.* 190:1447-1458 (2008)). The *M. thermoacetica* hydrogenases are 30 suitable candidates should the production host lack sufficient endogenous hydrogenase activity. *M. thermoacetica* can grow with CO₂ as the exclusive carbon source, indicating that reducing equivalents are extracted from H₂ to allow acetyl-CoA synthesis via the Wood-Ljungdahl pathway (Drake, *J. Bacteriol.* 150:702-709 (1982); Drake and Daniel, *Res. Microbiol.* 155:869-883 (2004); Kellum and Drake, *J. Bacteriol.* 160:466-469 (1984)) (see Figure 6). *M.*

thermoacetica has homologs to several *hyp*, *hyc*, and *hyf* genes from *E. coli*. These protein sequences encoded for by these genes can be identified by the following GenBank accession numbers. In addition, several gene clusters encoding hydrogenase and/or heterodisulfide reductase functionality are present in *M. thermoacetica* and their corresponding protein sequences are also provided below.

Hyp assembly proteins.

	<u>Protein</u>	<u>GenBank ID</u>	<u>Organism</u>
	HypA	NP_417206	<i>Escherichia coli</i>
	HypB	NP_417207	<i>Escherichia coli</i>
10	HypC	NP_417208	<i>Escherichia coli</i>
	HypD	NP_417209	<i>Escherichia coli</i>
	HypE	NP_417210	<i>Escherichia coli</i>
	HypF	NP_417192	<i>Escherichia coli</i>

Proteins in *M. thermoacetica* whose genes are homologous to the *E. coli hyp* genes.

	<u>Protein</u>	<u>GenBank ID</u>	<u>Organism</u>
15	Moth_2175	YP_431007	<i>Moorella thermoacetica</i>
	Moth_2176	YP_431008	<i>Moorella thermoacetica</i>
	Moth_2177	YP_431009	<i>Moorella thermoacetica</i>
	Moth_2178	YP_431010	<i>Moorella thermoacetica</i>
20	Moth_2179	YP_431011	<i>Moorella thermoacetica</i>
	Moth_2180	YP_431012	<i>Moorella thermoacetica</i>
	Moth_2181	YP_431013	<i>Moorella thermoacetica</i>

Hydrogenase 3.

	<u>Protein</u>	<u>GenBank ID</u>	<u>Organism</u>
25	HycA	NP_417205	<i>Escherichia coli</i>
	HycB	NP_417204	<i>Escherichia coli</i>
	HycC	NP_417203	<i>Escherichia coli</i>
	HycD	NP_417202	<i>Escherichia coli</i>
30	HycE	NP_417201	<i>Escherichia coli</i>
	HycF	NP_417200	<i>Escherichia coli</i>
	HycG	NP_417199	<i>Escherichia coli</i>
	HycH	NP_417198	<i>Escherichia coli</i>
	HycI	NP_417197	<i>Escherichia coli</i>

Hydrogenase 4.

	<u>Protein</u>	<u>GenBank ID</u>	<u>Organism</u>
	HyfA	NP_416976	<i>Escherichia coli</i>
	HyfB	NP_416977	<i>Escherichia coli</i>
5	HyfC	NP_416978	<i>Escherichia coli</i>
	HyfD	NP_416979	<i>Escherichia coli</i>
	HyfE	NP_416980	<i>Escherichia coli</i>
	HyfF	NP_416981	<i>Escherichia coli</i>
	HyfG	NP_416982	<i>Escherichia coli</i>
10	HyfH	NP_416983	<i>Escherichia coli</i>
	HyfI	NP_416984	<i>Escherichia coli</i>
	HyfJ	NP_416985	<i>Escherichia coli</i>
	HyfR	NP_416986	<i>Escherichia coli</i>

Proteins in *M. thermoacetica* whose genes are homologous to the *E. coli* hyc and/or hyf genes.

	<u>Protein</u>	<u>GenBank ID</u>	<u>Organism</u>
15	Moth_2182	YP_431014	<i>Moorella thermoacetica</i>
	Moth_2183	YP_431015	<i>Moorella thermoacetica</i>
	Moth_2184	YP_431016	<i>Moorella thermoacetica</i>
	Moth_2185	YP_431017	<i>Moorella thermoacetica</i>
20	Moth_2186	YP_431018	<i>Moorella thermoacetica</i>
	Moth_2187	YP_431019	<i>Moorella thermoacetica</i>
	Moth_2188	YP_431020	<i>Moorella thermoacetica</i>
	Moth_2189	YP_431021	<i>Moorella thermoacetica</i>
	Moth_2190	YP_431022	<i>Moorella thermoacetica</i>
25	Moth_2191	YP_431023	<i>Moorella thermoacetica</i>
	Moth_2192	YP_431024	<i>Moorella thermoacetica</i>

Additional hydrogenase-encoding gene clusters in *M. thermoacetica*.

	<u>Protein</u>	<u>GenBank ID</u>	<u>Organism</u>
30	Moth_0439	YP_429313	<i>Moorella thermoacetica</i>
	Moth_0440	YP_429314	<i>Moorella thermoacetica</i>
	Moth_0441	YP_429315	<i>Moorella thermoacetica</i>
	Moth_0442	YP_429316	<i>Moorella thermoacetica</i>
35	Moth_0809	YP_429670	<i>Moorella thermoacetica</i>
	Moth_0810	YP_429671	<i>Moorella thermoacetica</i>
	Moth_0811	YP_429672	<i>Moorella thermoacetica</i>
	Moth_0812	YP_429673	<i>Moorella thermoacetica</i>
	Moth_0813	(possible pseudogene, GenBank ID unavailable)	<i>Moorella thermoacetica</i>
40	Moth_0814	YP_429674	<i>Moorella thermoacetica</i>
	Moth_0815	YP_429675	<i>Moorella thermoacetica</i>
	Moth_0816	YP_429676	<i>Moorella thermoacetica</i>

	Moth_1193	YP_430050	<i>Moorella thermoacetica</i>
	Moth_1194	YP_430051	<i>Moorella thermoacetica</i>
	Moth_1195	YP_430052	<i>Moorella thermoacetica</i>
5	Moth_1196	YP_430053	<i>Moorella thermoacetica</i>
	Moth_1717	YP_430562	<i>Moorella thermoacetica</i>
	Moth_1718	YP_430563	<i>Moorella thermoacetica</i>
	Moth_1719	YP_430564	<i>Moorella thermoacetica</i>
10			
	Moth_1883	YP_430726	<i>Moorella thermoacetica</i>
	Moth_1884	YP_430727	<i>Moorella thermoacetica</i>
	Moth_1885	YP_430728	<i>Moorella thermoacetica</i>
	Moth_1886	YP_430729	<i>Moorella thermoacetica</i>
15	Moth_1887	YP_430730	<i>Moorella thermoacetica</i>
	Moth_1888	YP_430731	<i>Moorella thermoacetica</i>
	Moth_1452	YP_430305	<i>Moorella thermoacetica</i>
	Moth_1453	YP_430306	<i>Moorella thermoacetica</i>
20	Moth_1454	YP_430307	<i>Moorella thermoacetica</i>

A host organism engineered with these capabilities that also naturally possesses the capability for anapleurosis (for example, *E. coli*) can potentially grow more efficiently on the syngas-generated acetyl-CoA in the presence of a suitable external electron acceptor such as nitrate. This electron acceptor is required to accept electrons from the reduced quinone formed via succinate dehydrogenase. A further advantage of adding an external electron acceptor is that additional energy for cell growth, maintenance, and product formation can be generated from respiration of acetyl-CoA. An alternative strategy involves engineering a pyruvate ferredoxin oxidoreductase (PFOR) enzyme into the strain to allow synthesis of biomass precursors in the absence of an external electron acceptor.

Pyruvate ferredoxin oxidoreductase (PFOR). Anaerobic growth on synthesis gas and methanol in the absence of an external electron acceptor is conferred upon the host organism with ACS/CODH activity by allowing pyruvate synthesis via pyruvate ferredoxin oxidoreductase (PFOR). The PFOR from *Desulfovibrio africanus* has been cloned and expressed in *E. coli*, resulting in an active recombinant enzyme that was stable for several days in the presence of oxygen (Pieulle et al., *J. Bacteriol.* 179:5684-5692 (1997)). Oxygen stability is relatively uncommon in PFORS and is believed to be conferred by a 60 residue extension in the polypeptide chain of the *D. africanus* enzyme. The *M. thermoacetica* PFOR is also well characterized (Menon and Ragsdale, *Biochemistry* 36:8484-8494 (1997)) and was shown to have

high activity in the direction of pyruvate synthesis during autotrophic growth (Furdui and Ragsdale, *J. Biol. Chem.* 275:28494-28499 (2000)). Further, *E. coli* possesses an uncharacterized open reading frame, *ydbK*, that encodes a protein that is 51% identical to the *M. thermoacetica* PFOR. Evidence for pyruvate oxidoreductase activity in *E. coli* has been

5 described (Blaschkowski et al., *Eur. J. Biochem.* 123:563-569 (1982)). The protein sequences of these exemplary PFOR enzymes can be identified by the following GenBank accession numbers. Several additional PFOR enzymes have been described (Ragsdale, *Chem. Rev.* 103:2333-2346 (2003)).

	<u>Protein</u>	<u>GenBank ID</u>	<u>Organism</u>
10	Por	CAA70873.1	<i>Desulfovibrio africanus</i>
	Por	YP_428946.1	<i>Moorella thermoacetica</i>
	YdbK	NP_415896.1	<i>Escherichia coli</i>

This example describes exemplary gene sets for engineering an organism to produce acetyl-CoA from gasses comprising at least one of CO, CO₂, and H₂.

15

EXAMPLE IX

Engineering a Syngas Utilization Pathway into a Microorganism

This example describes engineering a microorganism to contain a syngas utilization pathway.

20 In addition to improving the efficiency of microorganisms such as *Clostridial* species that have the natural ability to utilize CO and/or CO₂ as a carbon source (Examples II, III and V), microorganisms that do not have the natural ability to utilize CO and/or CO₂ are engineered to express one or more proteins or enzymes that confer a CO and/or CO₂ utilization pathway. One exemplary pathway is the Wood-Ljungdahl pathway, which allows the utilization of CO and/or

25 CO₂ as a carbon source, thereby allowing the microorganism to utilize syngas or other gaseous carbon source (see Examples I and VII).

In initial studies, *Escherichia coli*, which does not utilize syngas naturally, is used as a target organism to introduce a CO and/or CO₂ utilization pathway such as the Wood-Ljungdahl pathway. The Wood-Ljungdahl pathway involves oxygen sensitive and membrane bound

30 proteins as well as specific co-factors that are not native in *E. coli*. While several Wood-Ljungdahl pathway genes have been cloned into *E. coli*, only one enzyme, methyltransferase, was found to be expressed in active form (Roberts et al., *Proc. Natl. Acad. Sci. USA* 86:32-36

(1989)). Purification of the carbonyl branch (see Figure 2) pathway genes from *Clostridium thermoaceticum* revealed the minimum set of enzymes required for *in vitro* conversion of methyl-THF to acetyl-CoA studies (Roberts et al., *J. Bacteriol.* 174:4667-4676 (1992)).

Initial studies are directed to engineering a Wood-Ljungdahl pathway, in particular the carbonyl
5 branch (Figure 2), into *E. coli* and testing growth and acetate production from both methyl-THF and syngas. *E. coli* provides a good model for developing a non-naturally occurring microorganism capable of utilizing syngas or other gaseous carbon sources since it is amenable to genetic manipulation and is known to be capable of producing various products like ethanol, acetate, and succinate effectively under anaerobic conditions from glucose.

10 To generate an *E. coli* strain engineered to contain a Wood-Ljungdahl pathway, nucleic acids encoding proteins and enzymes required for the carbonyl branch of the pathway (see Figure 2 and Example VII) are expressed in *E. coli* using well known molecular biology techniques (see, for example, Sambrook, *supra*, 2001; Ausubel *supra*, 1999; Roberts et al., *supra*, 1989). As described previously, the gene cluster encoding key proteins in acetyl-CoA synthesis in
15 *Clostridium thermoaceticum* has been cloned and expressed in *E. coli* (Roberts et al., *supra*, 1989). Specific variation of conditions, such as metal composition of the medium, is required to ensure production of active proteins. Genes encoding cobalamide corrinoid/iron-sulfur protein, methyltransferase, carbon monoxide dehydrogenase (CODH), acetyl-CoA synthase (ACS), acetyl-CoA synthase disulfide reductase, and a CO-tolerant hydrogenase are cloned and
20 expressed in *E. coli* to introduce carbonyl branch enzymes of the Wood-Ljungdahl pathway (for Wood-Ljungdahl pathway genes, see also Ragsdale, *Critical Rev. Biochem. Mol. Biol.* 39:165-195 (2004)). Since *E. coli* does not normally synthesize cobalamin or cobalamin-like cofactors, which is required for the cobalamide-corrinoid/iron sulfur protein activity, the cofactors or genes encoding proteins and enzymes for synthesis of the required cofactors can also be introduced.
25 The cobalamin or cobalamin-like cofactors can be provided to the medium, although cost would possibly prohibit this approach for scale up and commercial manufacture. A better alternative is to clone and express the requisite genes in the *E. coli* strain expressing the cobalamin-requiring proteins. This has been demonstrated by transfer and functional expression of a cobalamin operon containing 20 genes from *Salmonella typhimurium* into *E. coli* (Raux et al., *J. Bacteriol.*
30 178:753-767 (1996)).

The expression of Wood-Ljungdahl pathway genes is tested using routine assays for determining the expression of introduced genes, for example, Northern blots, PCR amplification of mRNA, immunoblotting, or other well known assays to confirm nucleic acid and protein expression of introduced genes. Enzymatic activity of the expressed enzymes can be tested individually or for production of a product such as acetyl-CoA (see, for example, Roberts et al., *supra*, 1989). The ability of the engineered *E. coli* strain to utilize CO and/or CO₂ as a carbon source to produce acetyl-CoA can be analyzed directly using gas chromatography-mass spectrometry (GCMS) or liquid chromatography-mass spectrometry (LCMS), or through the use of metabolic radioactive or isotopic labeling, for example, with radioactive CO or CO₂ and analysis of incorporation of radioactive label into the acetyl-CoA product or incorporation of an isotopically labeled CO or CO₂ precursor and analysis by techniques such as mass spectrometry (GCMS or LCMS) or nuclear magnetic resonance spectroscopy (NMR). Growth of *E. coli* using only CO and/or CO₂ as a sole carbon source, with or without the presence of H₂, is another useful test for a fully functional pathway.

Once a functional Wood-Ljungdahl pathway has been engineered into an *E. coli* strain, the strain is optimized for efficient utilization of the pathway. The engineered strain can be tested to determine if any of the introduced genes are expressed at a level that is rate limiting. As needed, increased expression of one or more proteins or enzymes that may limit the flux through the pathway can be used to optimize utilization of the pathway and production of acetyl-CoA.

Metabolic modeling can be utilized to optimize growth conditions (see Example II). Modeling can also be used to design gene knockouts that additionally optimize utilization of the pathway (see Examples II, IV and V and, for example, U.S. patent publications US 2002/0012939, US 2003/0224363, US 2004/0029149, US 2004/0072723, US 2003/0059792, US 2002/0168654 and US 2004/0009466, and in U.S. Patent No. 7,127,379). Modeling analysis allows predictions of the effects on cell growth of shifting the metabolism towards more efficient production of acetyl-CoA or other desired product. One modeling method is the bilevel optimization approach, OptKnock (Burgard et al., *Biotechnol. Bioengineer.* 84:647-657 (2003)), which is applied to select gene knockouts that collectively result in the growth-coupled production of acetyl-CoA or other desired products, as discussed below. Strains designed with a gene knockout strategy are forced, due to network stoichiometry, to produce high levels of a desired product for efficient growth, because all other growth options have been removed. Such strains are self-optimizing and stable. Accordingly, they typically maintain or improve upon production levels even in the

face of strong growth selective pressures, making them amenable to batch or continuous bioprocessing and also evolutionary engineering. Adaptive evolution can be used to further optimize the production of acetyl-CoA (see Example V). Adaptive evolution is therefore performed to improve both growth and production characteristics (Fong and Palsson, Nat. Genet. 5 36:1056-1058 (2004); Alper et al., Science 314:1565-1568 (2006)). Based on the results, subsequent rounds of modeling, genetic engineering and adaptive evolution can be utilized to further optimize production and tolerance of enzymes to syngas or impurities in syngas.

Once an engineered microbial strain has been optimized for utilization of the Wood-Ljungdahl pathway, optimization of the fermentation process can be performed to increase yields using well 10 known methods and as described, for example, in Example VI). For example, a productivity level of 20 g/L acetate at 0.5 g/L/h from syngas would represent a desirable production range towards which further optimization of the strain for efficient utilization of the pathway as well as optimization of fermentation conditions can be employed to achieve a desired production level.

Although exemplified with introduction of the carbonyl branch to confer the ability to utilize CO 15 and/or CO₂ to an engineered microbial strain, a similar approach is applied to introduce enzymes for production of methyl-THF to *E. coli*. As discussed above in Example VII, *E. coli* has the ability to produce methyl-THF, but THF-dependent enzymes from acetogens have higher specific activities (Morton et al., supra, 1993). Using methods as described above to introduce the carbonyl branch of the Wood-Ljungdahl pathway, methyl branch enzymes are introduced 20 into *E. coli* using similar techniques. Genes encoding one or more of the enzymes ferredoxin oxidoreductase, formate dehydrogenase, formyltetrahydrofolate synthetase, methenyltetrahydrofolate cyclodehydratase, methylenetetrahydrofolate dehydrogenase and methylenetetrahydrofolate reductase are introduced (see Figure 1). In this case, the genes are introduced to increase an endogenous enzyme activity and/or to increase the efficiency of 25 utilization of CO and/or CO₂ to produce methyl-THF. Optimization of the pathway and fermentation conditions is carried out as described above. In addition, both the carbonyl and methyl branches of the Wood-Ljungdahl pathway can be introduced into the same microorganism. In such an engineered organism, the increased production of methyl-THF from CO and/or CO₂ can be utilized to further increase the production of acetyl-CoA in an organism 30 engineered to utilize CO and/or CO₂ using the carbonyl branch of the Wood-Ljungdahl pathway (see Figures 3 and 6).

Acetyl-CoA can function as a precursor for other desired products. Once the acetyl-CoA-producing microorganism has been generated, additional genes can be introduced into the microorganism to utilize acetyl-CoA as a precursor to produce other desired products from CO and/or CO₂ as carbon source. For example, enzymes for butanol production can be introduced

5 (see Figure 3 and Example V). Representative genes for butanol pathway from acetyl-CoA are: AtoB, acetyl-CoA acetyltransferase; Thl, acetyl-CoA thiolase; Hbd, 3-hydroxybutyryl-CoA dehydrogenase; Crt, crotonase; Bcd, butyryl-CoA dehydrogenase; Etf, electron transfer flavoprotein; AdhE2, aldehyde/alcohol dehydrogenase (see Atsumi et al., *Metabolic Engineering* Sept. 14, 2007).

10 Metabolic pathways for production of additional desired products, including succinate, 4-hydroxybutyrate and 1,4-butanediol are described, for example, in U.S. application serial No. 11/891,602, filed August 10, 2007, and WO/2008/115840, and enzymes for such pathways can similarly be introduced, for example, succinyl-CoA ligase, succinyl-CoA: CoA transferase, succinate semialdehyde dehydrogenase, 4-hydroxybutyric acid dehydrogenase,

15 glutamate:succinic semialdehyde transaminase, 4-hydroxybutyryl-CoA transferase, a CoA-dependent aldehyde dehydrogenase, alcohol dehydrogenase, and the like. Acetyl-CoA feeds directly into the TCA cycle of all cells and succinate is a TCA cycle intermediate. Thus, additional enzymes conferring pathways capable of utilizing acetyl-CoA produced from CO and/or CO₂ can be engineered and optimized, as described above, to produce a desired product

20 from the engineered microorganism.

EXAMPLE X

Pathways for the Production of Acetyl-CoA from Synthesis Gas and Methanol

This example describes exemplary pathways for utilization of synthesis gas (syngas) and methanol to produce acetyl-CoA.

25 An organism capable of producing acetyl-CoA from syngas and methanol contains two key capabilities, which are depicted in Figure 7. One capability is a functional methyltransferase system that allows the production of 5-methyl-tetrahydrofolate (Me-THF) from methanol and THF. A second capability is the ability to combine CO, Coenzyme A, and the methyl group of Me-THF to form acetyl-CoA. The organism is able to 'fix' carbon from exogenous CO and/or

30 CO₂ and methanol to synthesize acetyl-CoA, cell mass, and products. This pathway to form acetyl-CoA from methanol and syngas is energetically advantageous compared to utilizing the

full Wood-Ljungdahl pathway. For example, the direct conversion of synthesis gas to acetate is an energetically neutral process (see Figure 6). Specifically, one ATP molecule is consumed during the formation of formyl-THF by formyl-THF synthase, and one ATP molecule is produced during the production of acetate via acetate kinase. This new strategy involving

5 methanol circumvents the ATP consumption requirement by ensuring that the methyl group on the methyl branch product, methyl-THF, is obtained from methanol rather than CO₂. This thereby ensures that acetate formation has a positive ATP yield that can help support cell growth and maintenance. A host organism engineered with these capabilities that also naturally possesses the capability for anaerobiosis (for example, *E. coli*) can grow on the methanol and

10 syngas-generated acetyl-CoA in the presence of a suitable external electron acceptor such as nitrate. This electron acceptor is required to accept electrons from the reduced quinone formed via succinate dehydrogenase. A further advantage of adding an external electron acceptor is that additional energy for cell growth, maintenance, and product formation can be generated from respiration of acetyl-CoA.

15 An alternative strategy involves engineering a pyruvate ferredoxin oxidoreductase (PFOR) enzyme into the strain to allow synthesis of biomass precursors in the absence of an external electron acceptor. A further characteristic of the engineered organism is the capability for extracting reducing equivalents from molecular hydrogen. This allows a high yield of reduced products such as ethanol, butanol, isobutanol, isopropanol, 1,4-butanediol, succinic acid, fumaric

20 acid, malic acid, 4-hydroxybutyric acid, 3-hydroxypropionic acid, lactic acid, methacrylic acid, adipic acid, and acrylic acid.

The organisms can produce acetyl-CoA, cell mass, and targeted chemicals from the following sources: 1) methanol and CO, 2) methanol, CO₂, and H₂, 3) methanol, CO, CO₂, and H₂, 4) methanol and synthesis gas comprising CO and H₂, and 5) methanol and synthesis gas

25 comprising CO, CO₂, and H₂.

Successfully engineering this pathway into an organism involves identifying an appropriate set of enzymes, cloning their corresponding genes into a production host, optimizing the stability and expression of these genes, optimizing fermentation conditions, and assaying for product formation following fermentation (see Examples II-IV). Described below are a number of

30 enzymes that catalyze each step of the pathway required for the conversion of synthesis gas and methanol to acetyl-CoA. To engineer a production host for the utilization of syngas and

methanol, one or more exogenous DNA sequence(s) encoding the requisite enzymes are expressed in the microorganism.

This example describes exemplary pathways for acetyl-CoA production from syngas and methanol.

5

EXAMPLE XI **Gene Sets for Generating Methanol and Syngas Utilizing Microorganisms**

This example describes exemplary gene sets for generating methanol and syngas utilizing microorganisms.

Methanol-methyltransferase (MTR). Expression of the modified Wood-Ljungdahl pathway in a foreign host (see Figure 7) requires introducing a set of methyltransferases to utilize the carbon and hydrogen provided by methanol and the carbon provided by CO and/or CO₂. A complex of 3 methyltransferase proteins, denoted MtaA, MtaB, and MtaC, perform the desired methanol methyltransferase activity (Naidu and Ragsdale, *J. Bacteriol.* 183:3276-3281 (2001); Ragsdale, *Crit. Rev. Biochem. Mol. Biol.* 39:165-195 (2004); Sauer et al., *Eur. J. Biochem.* 243:670-677 (1997); Tallant and Krzycki, *J. Bacteriol.* 178:1295-1301 (1996); Tallant and Krzycki, *J. Bacteriol.* 179:6902-6911 (1997); Tallant et al., *J. Biol. Chem.* 276:4485-4493 (2001)).

Methanol methyltransferase (MtaB) and Corrinoid protein (MtaC). MtaB is a zinc protein that catalyzes the transfer of a methyl group from methanol to MtaC, a corrinoid protein. Exemplary genes encoding MtaB and MtaC can be found in methanogenic archaea such as *Methanosarcina barkeri* (Maeder et al., *J. Bacteriol.* 188:7922-7931 (2006)) and *Methanosarcina acetivorans* (Galagan et al., *Genome Res.* 12:532-542 (2002)), as well as the acetogen, *Moorella thermoacetica* (Das et al., *Proteins* 67:167-176 (2007)). In general, the MtaB and MtaC genes are adjacent to one another on the chromosome as their activities are tightly interdependent. The protein sequences of various MtaB and MtaC encoding genes in *M. barkeri*, *M. acetivorans*, and *M. thermoaceticum* can be identified by their following GenBank accession numbers.

	<u>Protein</u>	<u>GenBank ID</u>	<u>Organism</u>
	MtaB1	YP_304299	<i>Methanosarcina barkeri</i>
	MtaC1	YP_304298	<i>Methanosarcina barkeri</i>
5	MtaB2	YP_307082	<i>Methanosarcina barkeri</i>
	MtaC2	YP_307081	<i>Methanosarcina barkeri</i>
	MtaB3	YP_304612	<i>Methanosarcina barkeri</i>
10	MtaC3	YP_304611	<i>Methanosarcina barkeri</i>
	MtaB1	NP_615421	<i>Methanosarcina acetivorans</i>
	MtaB1	NP_615422	<i>Methanosarcina acetivorans</i>
15	MtaB2	NP_619254	<i>Methanosarcina acetivorans</i>
	MtaC2	NP_619253	<i>Methanosarcina acetivorans</i>
	MtaB3	NP_616549	<i>Methanosarcina acetivorans</i>
	MtaC3	NP_616550	<i>Methanosarcina acetivorans</i>
20	MtaB	YP_430066	<i>Moorella thermoacetica</i>
	MtaC	YP_430065	<i>Moorella thermoacetica</i>

The MtaB1 and MtaC1 genes, YP_304299 and YP_304298, from *M. barkeri* were cloned into *E. coli* and sequenced (Sauer et al., *Eur. J. Biochem.* 243:670-677 (1997)). The crystal structure of this methanol-cobalamin methyltransferase complex is also available (Hagemeyer et al., *Proc. Natl. Acad. Sci. USA* 103:18917-18922 (2006)). The MtaB genes, YP_307082 and YP_304612, in *M. barkeri* were identified by sequence homology to YP_304299. In general, homology searches are an effective means of identifying methanol methyltransferases because MtaB encoding genes show little or no similarity to methyltransferases that act on alternative substrates such as trimethylamine, dimethylamine, monomethylamine, or dimethylsulfide. The MtaC genes, YP_307081 and YP_304611, were identified based on their proximity to the MtaB genes and also their homology to YP_304298. The three sets of MtaB and MtaC genes from *M. acetivorans* have been genetically, physiologically, and biochemically characterized (Pritchett and Metcalf, *Mol. Microbiol.* 56:1183-1194 (2005)). Mutant strains lacking two of the sets were able to grow on methanol, whereas a strain lacking all three sets of MtaB and MtaC genes sets could not grow on methanol. This suggests that each set of genes plays a role in methanol utilization. The *M. thermoacetica* MtaB gene was identified based on homology to the methanogenic MtaB genes and also by its adjacent chromosomal proximity to the methanol-induced corrinoid protein, MtaC, which has been crystallized (Zhou et al., *Acta Crystallogr. Sect.*

F Struct. Biol. Cryst. Commun. 61:537-540 (2005)) and further characterized by Northern hybridization and Western blotting (Das et al., *Proteins* 67:167-176 (2007)).

Methyltetrahydrofolate:corrinoide protein methyltransferase (MtaA). MtaA is zinc protein that catalyzes the transfer of the methyl group from MtaC either to Coenzyme M in methanogens or to tetrahydrofolate in acetogens. MtaA can also utilize methylcobalamin as the methyl donor. Exemplary genes encoding MtaA can be found in methanogenic archaea such as *Methanosarcina barkeri* (Maeder et al., *J. Bacteriol.* 188:7922-7931 (2006)) and *Methanosarcina acetivorans* (Galagan et al., *Genome Res.* 12:532-542 (2002)), as well as the acetogen, *Moorella thermoacetica* (Das et al., *Proteins* 67:167-176 (2007)). In general, MtaA proteins that catalyze the transfer of the methyl group from CH₃-MtaC are difficult to identify bioinformatically as they share similarity to other corrinoide protein methyltransferases and are not oriented adjacent to the MtaB and MtaC genes on the chromosomes. Nevertheless, a number of MtaA encoding genes have been characterized. The protein sequences of these genes in *M. barkeri* and *M. acetivorans* can be identified by the following GenBank accession numbers.

Protein	GenBank ID	Organism
MtaA	YP_304602	<i>Methanosarcina barkeri</i>
MtaA1	NP_619241	<i>Methanosarcina acetivorans</i>
MtaA2	NP_616548	<i>Methanosarcina acetivorans</i>

The MtaA gene, YP_304602, from *M. barkeri* was cloned, sequenced, and functionally overexpressed in *E. coli* (Harms and Thauer, *Eur. J. Biochem.* 235:653-659 (1996)). In *M. acetivorans*, MtaA1 is required for growth on methanol, whereas MtaA2 is dispensable even though methane production from methanol is reduced in MtaA2 mutants (Bose et al., *J. Bacteriol.* 190:4017-4026 (2008)). It is also important to note that there are multiple additional MtaA homologs in *M. barkeri* and *M. acetivorans* that are as yet uncharacterized, but may also catalyze corrinoide protein methyltransferase activity.

Putative MtaA encoding genes in *M. thermoacetica* were identified by their sequence similarity to the characterized methanogenic MtaA genes. Specifically, three *M. thermoacetica* genes show high homology (>30% sequence identity) to YP_304602 from *M. barkeri*. Unlike methanogenic MtaA proteins that naturally catalyze the transfer of the methyl group from CH₃-MtaC to Coenzyme M, an *M. thermoacetica* MtaA is likely to transfer the methyl group to tetrahydrofolate given the similar roles of tetrahydrofolate and Coenzyme M in methanogens and

acetogens, respectively. The protein sequences of putative MtaA encoding genes from *M. thermoacetica* can be identified by the following GenBank accession numbers.

	<u>Protein</u>	<u>GenBank ID</u>	<u>Organism</u>
	MtaA	YP_430937	<i>Moorella thermoacetica</i>
5	MtaA	YP_431175	<i>Moorella thermoacetica</i>
	MtaA	YP_430935	<i>Moorella thermoacetica</i>

Acetyl-CoA synthase/Carbon monoxide dehydrogenase (ACS/CODH). ACS/CODH is the central enzyme of the carbonyl branch of the Wood-Ljungdahl pathway. It catalyzes the reversible reduction of carbon dioxide to carbon monoxide and also the synthesis of acetyl-CoA from carbon monoxide, Coenzyme A, and the methyl group from a methylated corrinoid-iron-sulfur protein. The corrinoide-iron-sulfur-protein is methylated by methyltetrahydrofolate via a methyltransferase. Expression of ACS/CODH in a foreign host involves introducing many, if not all, of the following proteins and their corresponding activities.

15	Methyltetrahydrofolate:corrinoid protein methyltransferase (AcsE)
	Corrinoid iron-sulfur protein (AcsD)
	Nickel-protein assembly protein (AcsF)
	Ferredoxin (Orf7)
	Acetyl-CoA synthase (AcsB and AcsC)
	Carbon monoxide dehydrogenase (AcsA)
20	Nickel-protein assembly protein (CooC)

The genes required for carbon-monoxide dehydrogenase/acetyl-CoA synthase activity typically reside in a limited region of the native genome that may be an extended operon (Morton et al., *J. Biol. Chem.* 266:23824-23828 (1991); Ragsdale, *Crit. Rev. Biochem. Mol. Biol.* 39:165-195 (2004); Roberts et al., *Proc. Natl. Acad. Sci. USA* 86:32-36 (1989)). Each of the genes in this operon from the acetogen, *M. thermoacetica*, has already been cloned and expressed actively in *E. coli* (Lu et al., *J. Biol. Chem.* 268:5605-5614 (1993); Morton et al., *supra*, 1991; Roberts et al., *supra*, 1989)). The protein sequences of these genes can be identified by the following GenBank accession numbers.

	<u>Protein</u>	<u>GenBank ID</u>	<u>Organism</u>
	AcsE	YP_430054	<i>Moorella thermoacetica</i>
	AcsD	YP_430055	<i>Moorella thermoacetica</i>
	AcsF	YP_430056	<i>Moorella thermoacetica</i>
5	Orf7	YP_430057	<i>Moorella thermoacetica</i>
	AcsC	YP_430058	<i>Moorella thermoacetica</i>
	AcsB	YP_430059	<i>Moorella thermoacetica</i>
	AcsA	YP_430060	<i>Moorella thermoacetica</i>
	CooC	YP_430061	<i>Moorella thermoacetica</i>

10 The hydrogenogenic bacterium, *Carboxydotherrnus hydrogenoformans*, can utilize carbon monoxide as a growth substrate by means of acetyl-CoA synthase (Wu et al., *PLoS Genet.* 1:e65. (2005)). In strain Z-2901, the acetyl-CoA synthase enzyme complex lacks carbon monoxide dehydrogenase due to a frameshift mutation (We et al., *supra*, 2005), whereas in strain DSM 6008, a functional unframeshifted full-length version of this protein has been purified

15 (Svetlitchnyi et al., *Proc. Natl. Acad. Sci. USA* 101:446-451 (2004)). The protein sequences of the *C. hydrogenoformans* genes from strain Z-2901 can be identified by the following GenBank accession numbers. Sequences for *Carboxydotherrnus hydrogenoformans* DSM 6008 are not currently accessible in publicly available databases but can be readily determined as the sequences become available.

	<u>Protein</u>	<u>GenBank ID</u>	<u>Organism</u>
20	AcsE	YP_360065	<i>Carboxydotherrnus hydrogenoformans</i>
	AcsD	YP_360064	<i>Carboxydotherrnus hydrogenoformans</i>
	AcsF	YP_360063	<i>Carboxydotherrnus hydrogenoformans</i>
	Orf7	YP_360062	<i>Carboxydotherrnus hydrogenoformans</i>
25	AcsC	YP_360061	<i>Carboxydotherrnus hydrogenoformans</i>
	AcsB	YP_360060	<i>Carboxydotherrnus hydrogenoformans</i>
	CooC	YP_360059	<i>Carboxydotherrnus hydrogenoformans</i>

The methanogenic archaeon, *Methanosarcina acetivorans*, can also grow on carbon monoxide, exhibits acetyl-CoA synthase/carbon monoxide dehydrogenase activity, and produces both

30 acetate and formate (Lessner et al., *Proc. Natl. Acad. Sci. USA* 103:17921-17926 (2006)). This organism contains two sets of genes that encode ACS/CODH activity (Rother and Metcalf, *Proc. Natl. Acad. Sci. USA* 101:16929-16934 (2004)). The protein sequences of both sets of *M. acetivorans* genes can be identified by the following GenBank accession numbers.

	<u>Protein</u>	<u>GenBank ID</u>	<u>Organism</u>
	AcsC	NP_618736	<i>Methanosarcina acetivorans</i>
	AcsD	NP_618735	<i>Methanosarcina acetivorans</i>
	AcsF, CooC	NP_618734	<i>Methanosarcina acetivorans</i>
5	AcsB	NP_618733	<i>Methanosarcina acetivorans</i>
	AcsEps	NP_618732	<i>Methanosarcina acetivorans</i>
	AcsA	NP_618731	<i>Methanosarcina acetivorans</i>
10	AcsC	NP_615961	<i>Methanosarcina acetivorans</i>
	AcsD	NP_615962	<i>Methanosarcina acetivorans</i>
	AcsF, CooC	NP_615963	<i>Methanosarcina acetivorans</i>
	AcsB	NP_615964	<i>Methanosarcina acetivorans</i>
	AcsEps	NP_615965	<i>Methanosarcina acetivorans</i>
	AcsA	NP_615966	<i>Methanosarcina acetivorans</i>

15 The AcsC, AcsD, AcsB, AcsEps, and AcsA proteins are commonly referred to as the gamma, delta, beta, epsilon, and alpha subunits of the methanogenic CODH/ACS. Homologs to the epsilon encoding genes are not present in acetogens such as *M. thermoacetica* or hydrogenogenic bacteria such as *C. hydrogenoformans*. Hypotheses for the existence of two active CODH/ACS operons in *M. acetivorans* include catalytic properties (that is, K_m , V_{max} , k_{cat}) that favor
20 carboxidotrophic or acetoclastic growth or differential gene regulation enabling various stimuli to induce CODH/ACS expression (Rother et al., *Arch. Microbiol.* 188:463-472 (2007)).

In both *M. thermoacetica* and *C. hydrogenoformans*, additional CODH encoding genes are located outside of the ACS/CODH operons. These enzymes provide a means for extracting electrons (or reducing equivalents) from the conversion of carbon monoxide to carbon dioxide.
25 The reducing equivalents are then passed to accepters such as oxidized ferredoxin, NADP+, water, or hydrogen peroxide to form reduced ferredoxin, NADPH, H₂, or water, respectively. In some cases, hydrogenase encoding genes are located adjacent to a CODH. In *Rhodospirillum rubrum*, the encoded CODH/hydrogenase proteins form a membrane-bound enzyme complex that is proposed to be a site where energy, in the form of a proton gradient, is generated from the
30 conversion of CO to CO₂ and H₂ (Fox et al., *J. Bacteriol.* 178:6200-6208 (1996)). The CODH-I of *C. hydrogenoformans* and its adjacent genes have been proposed to catalyze a similar functional role based on their similarity to the *R. rubrum* CODH/hydrogenase gene cluster (Wu et al., *PLoS Genet.* 1:e65 (2005)). The *C. hydrogenoformans* CODH-I was also shown to exhibit intense CO oxidation and CO₂ reduction activities when linked to an electrode (Parkin et al., *J.*
35 *Am. Chem. Soc.* 129:10328-10329 (2007)). The genes encoding the *C. hydrogenoformans* CODH-II and CooF, a neighboring protein, were cloned and sequenced (Gonzalez and Robb,

FEMS Microbiol. Lett. 191:243-247 (2000)). The resulting complex was membrane-bound, although cytoplasmic fractions of CODH-II were shown to catalyze the formation of NADPH suggesting an anabolic role (Svetlitchnyi et al., *J. Bacteriol.* 183:5134-5144 (2001)). The crystal structure of the CODH-II is also available (Dobbek et al., *Science* 293:1281-1285 (2001)). The protein sequences of exemplary CODH and hydrogenase genes can be identified by the following GenBank accession numbers.

	<u>Protein</u>	<u>GenBank ID</u>	<u>Organism</u>
	CODH (putative)	YP_430813	<i>Moorella thermoacetica</i>
10	CODH-I (CooS-I)	YP_360644	<i>Carboxydothemus hydrogenoformans</i>
	CooF	YP_360645	<i>Carboxydothemus hydrogenoformans</i>
	HypA	YP_360646	<i>Carboxydothemus hydrogenoformans</i>
	CooH	YP_360647	<i>Carboxydothemus hydrogenoformans</i>
	CooU	YP_360648	<i>Carboxydothemus hydrogenoformans</i>
15	CooX	YP_360649	<i>Carboxydothemus hydrogenoformans</i>
	CooL	YP_360650	<i>Carboxydothemus hydrogenoformans</i>
	CooK	YP_360651	<i>Carboxydothemus hydrogenoformans</i>
	CooM	YP_360652	<i>Carboxydothemus hydrogenoformans</i>
20	CooM	AAC45116	<i>Rhodospirillum rubrum</i>
	CooK	AAC45117	<i>Rhodospirillum rubrum</i>
	CooL	AAC45118	<i>Rhodospirillum rubrum</i>
	CooX	AAC45119	<i>Rhodospirillum rubrum</i>
	CooU	AAC45120	<i>Rhodospirillum rubrum</i>
25	CooH	AAC45121	<i>Rhodospirillum rubrum</i>
	CooF	AAC45122	<i>Rhodospirillum rubrum</i>
	CODH (CooS)	AAC45123	<i>Rhodospirillum rubrum</i>
	CooC	AAC45124	<i>Rhodospirillum rubrum</i>
	CooT	AAC45125	<i>Rhodospirillum rubrum</i>
30	CooJ	AAC45126	<i>Rhodospirillum rubrum</i>
	CODH-II (CooS-II)	YP_358957	<i>Carboxydothemus hydrogenoformans</i>
	CooF	YP_358958	<i>Carboxydothemus hydrogenoformans</i>

Pyruvate ferredoxin oxidoreductase (PFOR). Anaerobic growth on synthesis gas and methanol in the absence of an external electron acceptor is conferred upon the host organism with MTR and ACS/CODH activity by allowing pyruvate synthesis via pyruvate ferredoxin oxidoreductase (PFOR). The PFOR from *Desulfovibrio africanus* has been cloned and expressed in *E. coli*, resulting in an active recombinant enzyme that was stable for several days in the presence of oxygen (Pieulle et al., *J. Bacteriol.* 179:5684-5692 (1997)). Oxygen stability is relatively uncommon in PFORs and is believed to be conferred by a 60 residue extension in

the polypeptide chain of the *D. africanus* enzyme. The *M. thermoacetica* PFOR is also well characterized (Menon and Ragsdale, *Biochemistry* 36:8484-8494 (1997)) and was shown to have high activity in the direction of pyruvate synthesis during autotrophic growth (Furdui and Ragsdale, *J. Biol. Chem.* 275:28494-28499 (2000)). Further, *E. coli* possesses an uncharacterized open reading frame, *ydbK*, that encodes a protein that is 51% identical to the *M. thermoacetica* PFOR. Evidence for pyruvate oxidoreductase activity in *E. coli* has been described (Blaschkowski et al., *Eur. J. Biochem.* 123:563-569 (1982)). The protein sequences of these exemplary PFOR enzymes can be identified by the following GenBank accession numbers. Several additional PFOR enzymes have been described (Ragsdale, *Chem. Rev.* 103:2333-2346 (2003)).

<u>Protein</u>	<u>GenBank ID</u>	<u>Organism</u>
Por	CAA70873.1	<i>Desulfovibrio africanus</i>
Por	YP_428946.1	<i>Moorella thermoacetica</i>
YdbK	NP_415896.1	<i>Escherichia coli</i>

Hydrogenase (Hyd). Unlike the redox neutral conversion of CO and methanol to acetyl-CoA or acetate, the production of more highly reduced products such as ethanol, butanol, isobutanol, isopropanol, 1,4-butanediol, succinic acid, fumaric acid, malic acid, 4-hydroxybutyric acid, 3-hydroxypropionic acid, lactic acid, methacrylic acid, adipic acid, and acrylic acid at the highest possible yield requires the extraction of additional reducing equivalents from both CO and H₂ (for example, see ethanol formation in Figure 7). Specifically, reducing equivalents (for example, 2 [H] in Figure 6) are obtained by the conversion of CO and water to CO₂ via carbon monoxide dehydrogenase as described in Example II or directly from the activity of a hydrogen-utilizing hydrogenase which transfers electrons from H₂ to an acceptor such as ferredoxin, flavodoxin, FAD⁺, NAD⁺, or NADP⁺.

Native to *E. coli* and other enteric bacteria are multiple genes encoding up to four hydrogenases (Sawers, *Antonie Van Leeuwenhoek* 66:57-88 (1994); Sawers et al., *J. Bacteriol.* 164:1324-1331 (1985); Sawers and Boxer, *Eur. J. Biochem.* 156:265-275 (1986); Sawers et al., *J. Bacteriol.* 168:398-404 (1986)). Given the multiplicity of enzyme activities, it is possible that *E. coli* or another host organism can provide sufficient hydrogenase activity to split incoming molecular hydrogen and reduce the corresponding acceptor. Among the endogenous hydrogen-lyase enzymes of *E. coli* are hydrogenase 3, a membrane-bound enzyme complex using ferredoxin as an acceptor, and hydrogenase 4, which also uses a ferredoxin acceptor. Hydrogenase 3 and 4 are

encoded by the *hyc* and *hyf* gene clusters, respectively. Hydrogenase activity in *E. coli* is also dependent upon the expression of the *hyp* genes whose corresponding proteins are involved in the assembly of the hydrogenase complexes (Jacobi et al., *Arch. Microbiol.* 158:444-451 (1992); Rangarajan et al., *J. Bacteriol.* 190:1447-1458 (2008)). The *M. thermoacetica* hydrogenases are suitable candidates should the production host lack sufficient endogenous hydrogenase activity. *M. thermoacetica* can grow with CO₂ as the exclusive carbon source, indicating that reducing equivalents are extracted from H₂ to allow acetyl-CoA synthesis via the Wood-Ljungdahl pathway (Drake, *J. Bacteriol.* 150:702-709 (1982); Drake and Daniel, *Res. Microbiol.* 155:869-883 (2004); Kellum and Drake, *J. Bacteriol.* 160:466-469 (1984)) (see Figure 6). *M. thermoacetica* has homologs to several *hyp*, *hyc*, and *hyf* genes from *E. coli*. These protein sequences encoded for by these genes can be identified by the following GenBank accession numbers. In addition, several gene clusters encoding hydrogenase and/or heterodisulfide reductase functionality are present in *M. thermoacetica* and their corresponding protein sequences are also provided below.

15 Hyp assembly proteins.

	<u>Protein</u>	<u>GenBank ID</u>	<u>Organism</u>
	HypA	NP_417206	<i>Escherichia coli</i>
	HypB	NP_417207	<i>Escherichia coli</i>
	HypC	NP_417208	<i>Escherichia coli</i>
20	HypD	NP_417209	<i>Escherichia coli</i>
	HypE	NP_417210	<i>Escherichia coli</i>
	HypF	NP_417192	<i>Escherichia coli</i>

Proteins in *M. thermoacetica* whose genes are homologous to the *E. coli hyp* genes.

	<u>Protein</u>	<u>GenBank ID</u>	<u>Organism</u>
25	Moth_2175	YP_431007	<i>Moorella thermoacetica</i>
	Moth_2176	YP_431008	<i>Moorella thermoacetica</i>
	Moth_2177	YP_431009	<i>Moorella thermoacetica</i>
	Moth_2178	YP_431010	<i>Moorella thermoacetica</i>
	Moth_2179	YP_431011	<i>Moorella thermoacetica</i>
30	Moth_2180	YP_431012	<i>Moorella thermoacetica</i>
	Moth_2181	YP_431013	<i>Moorella thermoacetica</i>

Hydrogenase 3.

	<u>Protein</u>	<u>GenBank ID</u>	<u>Organism</u>
	HycA	NP_417205	<i>Escherichia coli</i>
	HycB	NP_417204	<i>Escherichia coli</i>
5	HycC	NP_417203	<i>Escherichia coli</i>
	HycD	NP_417202	<i>Escherichia coli</i>
	HycE	NP_417201	<i>Escherichia coli</i>
	HycF	NP_417200	<i>Escherichia coli</i>
	HycG	NP_417199	<i>Escherichia coli</i>
10	HycH	NP_417198	<i>Escherichia coli</i>
	HycI	NP_417197	<i>Escherichia coli</i>

Hydrogenase 4.

	<u>Protein</u>	<u>GenBank ID</u>	<u>Organism</u>
	HyfA	NP_416976	<i>Escherichia coli</i>
15	HyfB	NP_416977	<i>Escherichia coli</i>
	HyfC	NP_416978	<i>Escherichia coli</i>
	HyfD	NP_416979	<i>Escherichia coli</i>
	HyfE	NP_416980	<i>Escherichia coli</i>
	HyfF	NP_416981	<i>Escherichia coli</i>
20	HyfG	NP_416982	<i>Escherichia coli</i>
	HyfH	NP_416983	<i>Escherichia coli</i>
	HyfI	NP_416984	<i>Escherichia coli</i>
	HyfJ	NP_416985	<i>Escherichia coli</i>
	HyfR	NP_416986	<i>Escherichia coli</i>

25 Proteins in *M. thermoacetica* whose genes are homologous to the *E. coli* hyc and/or hyf genes.

	<u>Protein</u>	<u>GenBank ID</u>	<u>Organism</u>
	Moth_2182	YP_431014	<i>Moorella thermoacetica</i>
	Moth_2183	YP_431015	<i>Moorella thermoacetica</i>
	Moth_2184	YP_431016	<i>Moorella thermoacetica</i>
30	Moth_2185	YP_431017	<i>Moorella thermoacetica</i>
	Moth_2186	YP_431018	<i>Moorella thermoacetica</i>
	Moth_2187	YP_431019	<i>Moorella thermoacetica</i>
	Moth_2188	YP_431020	<i>Moorella thermoacetica</i>
	Moth_2189	YP_431021	<i>Moorella thermoacetica</i>
35	Moth_2190	YP_431022	<i>Moorella thermoacetica</i>
	Moth_2191	YP_431023	<i>Moorella thermoacetica</i>
	Moth_2192	YP_431024	<i>Moorella thermoacetica</i>

Additional hydrogenase-encoding gene clusters in *M. thermoacetica*.

	<u>Protein</u>	<u>GenBank ID</u>	<u>Organism</u>
	Moth_0439	YP_429313	<i>Moorella thermoacetica</i>
	Moth_0440	YP_429314	<i>Moorella thermoacetica</i>
5	Moth_0441	YP_429315	<i>Moorella thermoacetica</i>
	Moth_0442	YP_429316	<i>Moorella thermoacetica</i>
	Moth_0809	YP_429670	<i>Moorella thermoacetica</i>
	Moth_0810	YP_429671	<i>Moorella thermoacetica</i>
10	Moth_0811	YP_429672	<i>Moorella thermoacetica</i>
	Moth_0812	YP_429673	<i>Moorella thermoacetica</i>
	Moth_0813	(possible psuedogene, GenBank ID unavailable)	<i>Moorella thermoacetica</i>
	Moth_0814	YP_429674	<i>Moorella thermoacetica</i>
15	Moth_0815	YP_429675	<i>Moorella thermoacetica</i>
	Moth_0816	YP_429676	<i>Moorella thermoacetica</i>
	Moth_1193	YP_430050	<i>Moorella thermoacetica</i>
	Moth_1194	YP_430051	<i>Moorella thermoacetica</i>
20	Moth_1195	YP_430052	<i>Moorella thermoacetica</i>
	Moth_1196	YP_430053	<i>Moorella thermoacetica</i>
	Moth_1717	YP_430562	<i>Moorella thermoacetica</i>
	Moth_1718	YP_430563	<i>Moorella thermoacetica</i>
25	Moth_1719	YP_430564	<i>Moorella thermoacetica</i>
	Moth_1883	YP_430726	<i>Moorella thermoacetica</i>
	Moth_1884	YP_430727	<i>Moorella thermoacetica</i>
	Moth_1885	YP_430728	<i>Moorella thermoacetica</i>
30	Moth_1886	YP_430729	<i>Moorella thermoacetica</i>
	Moth_1887	YP_430730	<i>Moorella thermoacetica</i>
	Moth_1888	YP_430731	<i>Moorella thermoacetica</i>
	Moth_1452	YP_430305	<i>Moorella thermoacetica</i>
35	Moth_1453	YP_430306	<i>Moorella thermoacetica</i>
	Moth_1454	YP_430307	<i>Moorella thermoacetica</i>

This example describes exemplary gene sets for engineering an organism to produce acetyl-CoA from syngas and methanol.

EXAMPLE XII**40 Cloning, Expression and Activity Assays for Genes and Encoded Enzymes for Engineering an Organism to Produce Acetyl-CoA from Synthesis Gas and Methanol**

This example describes the cloning and expression of genes encoding enzymes that provide a syngas and methanol utilizing organism.

Methanol-methyltransferase (MTR). At least the minimal set of genes, for example, MtaA, MtaB, and MtaC, for producing Me-THF from methanol are cloned and expressed in *E. coli*. These genes are cloned via proof-reading PCR and linked together for expression in a high-copy number vector such as pZE22-S under control of the repressible PA1-lacO1 promoter (Lutz and Bujard, *Nucleic Acids Res.* 25:1203-1210 (1997)). Coenzyme B12 is added to the growth medium as these methyltransferase activities require cobalamin as a cofactor. Cloned genes are verified by PCR and/or restriction enzyme mapping to demonstrate construction and insertion of the 3-gene set into the expression vector. DNA sequencing of the presumptive clones is carried out to confirm the expected sequences of each gene. Once confirmed, the final construct is expressed in *E. coli* K-12 (MG1655) cells by addition of isopropyl β -D-1-thiogalactopyranoside (IPTG) inducer between 0.05 and 1 mM final concentration. Expression of the cloned genes is monitored using SDS-PAGE of whole cell extracts. To determine if expression of the MtaABC proteins confers upon *E. coli* the ability to transfer methyl groups from methanol to tetrahydrofolate (THF), methanol is fed to the recombinant strain at varying concentrations and its uptake is monitored along with methyl-THF synthesis. Activity of the methyltransferase system is assayed anaerobically as described for vanillate as a methyl source in *M. thermoacetica* (Naidu and Ragsdale, *J. Bacteriol.* 183:3276-3281 (2001)) or for the *Methanosarcina barkeri* methanol methyltransferase (Sauer et al., *Eur. J. Biochem.* 243:670-677 (1997); Tallant and Krzycki. *J. Bacteriol.* 178:1295-1301 (1996); Tallant and Krzycki. *J. Bacteriol.* 179:6902-6911 (1997); Tallant et al., *J. Biol. Chem.* 276:4485-4493 (2001)). For a positive control, *E. coli* cells are cultured in parallel, and endogenous methyltransferase activity is monitored. Demonstration that activity depends on exogenously added coenzyme B12 confirms expression of methanol:corrinoid methyltransferase activity in *E. coli*.

Acetyl-CoA synthase/Carbon monoxide dehydrogenase (ACS/CODH). Using standard PCR methods, the entire operons encoding the genes essential for ACS/CODH activity from *M. thermoacetica*, *C. hydrogenoformans*, and *M. acetivorans* are assembled into a low or medium copy number vector such as pZA33-S (P15A-based) or pZS13-S (pSC101-based). As described for the methyltransferase genes, the structure and sequence of the cloned genes are confirmed. Expression is monitored via protein gel electrophoresis of whole-cell lysates grown under strictly anaerobic conditions with the requisite metals (Ni, Zn, Fe) and coenzyme B12 provided. As necessary, the gene cluster is modified for *E. coli* expression by identification and removal of any apparent terminators and introduction of consensus ribosomal binding sites chosen from sites

known to be effective in *E. coli* (Barrick et al., *Nucleic Acids Res.* 22:1287-1295 (1994); Ringquist et al., *Mol. Microbiol.* 6:1219-1229 (1992)). However, each gene cluster is cloned and expressed in a manner parallel to its native structure and expression. This helps ensure the desired stoichiometry between the various gene products, most of which interact with each other.

5 Once satisfactory expression of the CODH/ACS gene cluster under anaerobic conditions is achieved, the ability of cells expressing these genes to fix CO and/or CO₂ into cellular carbon is assayed. Initial conditions employ strictly anaerobically grown cells provided with exogenous glucose as a carbon and energy source via substrate-level phosphorylation or anaerobic respiration with nitrate as an electron acceptor. Additionally, exogenously provided CH₃-THF is
10 added to the medium.

Assaying activity of the combined MTR and ACS/CODH pathway. The ACS/CODH genes as described in Example II are cloned and expressed in cells also expressing the methanol-methyltransferase system also as described in Example II. This is achieved by introduction of compatible plasmids expressing ACS/CODH into MTR-expressing cells. For added long-term
15 stability, the ACS/CODH and MTR genes can also be integrated into the chromosome. After strains of *E. coli* capable of utilizing methanol to produce Me-THF and of expressing active CODH/ACS gene are made, they are assayed for the ability to utilize both methanol and syngas for incorporation into cell mass and acetate. Initial conditions employ strictly anaerobically grown cells provided with exogenous glucose as a carbon and energy source. Alternatively, or in
20 addition to glucose, nitrate can be added to the fermentation broth to serve as an electron acceptor and initiator of growth. Anaerobic growth of *E. coli* on fatty acids, which are ultimately metabolized to acetyl-CoA, has been demonstrated in the presence of nitrate (Campbell et al., *Mol. Microbiol.* 47:793-805 (2003)). Similar conditions can be employed by culturing the microbial organisms in the presence of an electron acceptor such as nitrate. Oxygen can also be
25 provided as long as its intracellular levels are maintained below any inhibition threshold of the engineered enzymes. "Synthetic syngas" of a composition suitable for these experiments is employed along with methanol. ¹³C-labeled methanol or ¹³C-labeled CO are provided to the cells, and analytical mass spectrometry is employed to measure incorporation of the labeled carbon into acetate and cell mass, for example, proteinogenic amino acids.

30 **Pyruvate ferredoxin oxidoreductase.** The pyruvate ferredoxin oxidoreductase genes from *M. thermoacetica*, *D. africanus*, and *E. coli* are cloned and expressed in strains exhibiting MTR and ACS/CODH activities. Conditions, promoters, and the like, are described above. Given the

large size of the PFOR genes and oxygen sensitivity of the corresponding enzymes, tests are performed using low or single-copy plasmid vectors or single-copy chromosomal integrations. Activity assays (as described in Furdai and Ragsdale, *J. Biol. Chem.* 275:28494-28499 (2000)) are applied to demonstrate activity. In addition, demonstration of growth on the gaseous carbon sources and methanol in the absence of an external electron acceptor provides further evidence for PFOR activity *in vivo*.

Hydrogenase. The endogenous hydrogen-utilizing hydrogenase activity of the host organism is tested by growing the cells as described above in the presence and absence of hydrogen. If a dramatic shift towards the formation of more reduced products during fermentation is observed (for example, increased ethanol as opposed to acetate), this indicates that endogenous hydrogenase activity is sufficiently active. In this case, no heterologous hydrogenases are cloned and expressed. If the native enzymes do not have sufficient activity or reduce the needed acceptor, the genes encoding an individual hydrogenase complex are cloned and expressed in strains exhibiting MTR, ACS/CODH, and PFOR activities. Conditions, promoters, and the like, are described above.

This example describes the cloning and expression of genes conferring a syngas and methanol utilization pathway and assay for appropriate activities.

EXAMPLE XIII

Development and Optimization of Fermentation Process for Production of Acetyl-CoA from an Organism Engineered to Utilize Syngas and Methanol

This example describes development and optimization of fermentation conditions for syngas and methanol utilizing organisms.

Important process considerations for a syngas fermentation are high biomass concentration and good gas-liquid mass transfer (Bredwell et al., *Biotechnol. Prog.* 15:834-844 (1999)). The solubility of CO in water is somewhat less than that of oxygen. Continuously gas-sparged fermentations can be performed in controlled fermenters with constant off-gas analysis by mass spectrometry and periodic liquid sampling and analysis by GC and HPLC. The liquid phase can function in batch mode. Fermentation products such as alcohols, organic acids, and residual glucose along with residual methanol are quantified by HPLC (Shimadzu, Columbia MD), for example, using an Aminex® series of HPLC columns (for example, HPX-87 series) (BioRad, Hercules CA), using a refractive index detector for glucose and alcohols, and a UV detector for

organic acids. The growth rate is determined by measuring optical density using a spectrophotometer (600 nm). All piping in these systems is glass or metal to maintain anaerobic conditions. The gas sparging is performed with glass frits to decrease bubble size and improve mass transfer. Various sparging rates are tested, ranging from about 0.1 to 1 vvm (vapor
5 volumes per minute). To obtain accurate measurements of gas uptake rates, periodic challenges are performed in which the gas flow is temporarily stopped, and the gas phase composition is monitored as a function of time.

In order to achieve the overall target productivity, methods of cell retention or recycle are employed. One method to increase the microbial concentration is to recycle cells via a tangential
10 flow membrane from a sidestream. Repeated batch culture can also be used, as previously described for production of acetate by *Moorella* (Sakai et al., *J. Biosci. Bioeng.* 99:252-258 (2005)). Various other methods can also be used (Bredwell et al., *Biotechnol. Prog.* 15:834-844 (1999); Datar et al., *Biotechnol. Bioeng.* 86:587-594 (2004)). Additional optimization can be tested such as overpressure at 1.5 atm to improve mass transfer (Najafpour and Younesi, *Enzyme
15 and Microbial Technology* 38:223-228 (2006)).

Once satisfactory performance is achieved using pure H₂/CO as the feed, synthetic gas mixtures are generated containing inhibitors likely to be present in commercial syngas. For example, a typical impurity profile is 4.5% CH₄, 0.1% C₂H₂, 0.35% C₂H₆, 1.4% C₂H₄, and 150 ppm nitric oxide (Datar et al., *Biotechnol. Bioeng.* 86:587-594 (2004)). Tars, represented by compounds
20 such as benzene, toluene, ethylbenzene, p-xylene, o-xylene, and naphthalene, are added at ppm levels to test for any effect on production. For example, it has been shown that 40 ppm NO is inhibitory to *C. carboxidivorans* (Ahmed and Lewis, *Biotechnol. Bioeng.* 97:1080-1086 (2007)). Cultures are tested in shake-flask cultures before moving to a fermentor. Also, different levels of these potential inhibitory compounds are tested to quantify the effect they have on cell growth.
25 This knowledge is used to develop specifications for syngas purity, which is utilized for scale up studies and production. If any particular component is found to be difficult to decrease or remove from syngas used for scale up, an adaptive evolution procedure is utilized to adapt cells to tolerate one or more impurities.

This example describes development and optimization of fermentation conditions for syngas and
30 methanol utilizing organisms.

EXAMPLE XIV
Methods for Handling CO and Anaerobic Cultures

This example describes methods for handling CO and anaerobic cultures.

Handling of CO in small quantities for assays and small cultures. CO is an odorless, colorless
5 and tasteless gas that is a poison. Therefore, cultures and assays that utilize CO can require
special handling. Several assays, including CO oxidation, acetyl-CoA synthesis, CO
concentration using myoglobin, and CO tolerance/utilization in small batch cultures, call for
small quantities of the CO gas that can be dispensed and handled within a fume hood. The
10 biochemical assays called for saturating very small quantities (<2 ml) of the biochemical assay
medium or buffer with CO and then performing the assay. All of the CO handling steps were
performed in a fume hood with the sash set at the proper height and blower turned on; CO was
dispensed from a compressed gas cylinder and the regulator connected to a Schlenk line. The
latter ensures that equal concentrations of CO will be dispensed to each of several possible
15 cuvettes or vials. The Schlenk line was set up containing an oxygen scrubber on the input side
and an oil pressure release bubbler and vent on the other side. Alternatively, a cold trap can be
used. Assay cuvettes were both anaerobic and CO-containing. Therefore, the assay cuvettes were
tightly sealed with a rubber stopper and reagents added or removed using gas-tight needles and
syringes. Secondly, small (~50 ml) cultures were grown with saturating CO in tightly stoppered
20 serum bottles. As with the biochemical assays, the CO-saturated microbial cultures were
equilibrated in the fume hood using the Schlenk line setup. Both the biochemical assays and
microbial cultures were in portable, sealed containers and in small volumes making for safe
handling outside of the fume hood. The compressed CO tank was adjacent to the fume hood.

Typically, a Schlenk line was used to dispense CO to cuvettes, each vented. Rubber stoppers on
the cuvettes are pierced with 19 or 20 gage disposable syringe needles and are vented with the
25 same. An oil bubbler is used with a CO tank and oxygen scrubber. The glass or quartz
spectrophotometer cuvettes have a circular hole on top into which a Kontes stopper sleeve, Sz7
774250-0007 was fitted. The CO detector unit was positioned proximal to the fume hood.

Handling of CO in larger quantities fed to large-scale cultures. Fermentation cultures are fed
either CO or a mixture of CO and H₂ to simulate syngas or syngas as a feedstock in fermentative
30 production. Therefore, quantities of cells ranging from 1 liter to several liters can include the
addition of CO gas to increase the dissolved concentration of CO in the medium. In these

circumstances, fairly large and continuously administered quantities of CO gas will be added to the cultures. At different points, the cultures are harvested or samples removed. Alternatively, cells can be harvested with an integrated continuous flow centrifuge that is part of the fermenter.

The fermentative processes are generally carried out under anaerobic conditions. In some cases, it is uneconomical to pump oxygen or air into fermenters to ensure adequate oxygen saturation to provide a respiratory environment. In addition, the reducing power generated during anaerobic fermentation is likely to be needed in product formation rather than respiration. Furthermore, many of the enzymes being considered for various pathways are oxygen-sensitive to varying degrees. Classic acetogens such as *M. thermoacetica* are obligate anaerobes and the enzymes in the Wood-Ljungdahl pathway are highly sensitive to irreversible inactivation by molecular oxygen. While there are oxygen-tolerant acetogens, the repertoire of enzymes in the Wood-Ljungdahl pathway are likely to all have issues in the presence of oxygen because most are metallo-enzymes, key components are ferredoxins, and regulation may divert metabolism away from the Wood-Ljungdahl pathway to maximize energy acquisition. At the same time, cells in culture act as oxygen scavengers that moderate the need for extreme measures in the presence of large cell growth.

Anaerobic chamber and conditions. Exemplary anaerobic chambers are available commercially (see, for example, Vacuum Atmospheres Company, Hawthorne CA; MBraun, Newburyport MA). Exemplary conditions include an O₂ concentration of 1 ppm or less and 1 atm pure N₂. In one example, 3 oxygen scrubbers/catalyst regenerators can be used, and the chamber can include an O₂ electrode (such as Teledyne; City of Industry CA). Nearly all items and reagents are cycled 4X in the airlock of the chamber prior to opening the inner chamber door. Reagents with a volume >5ml are sparged with pure N₂ prior to introduction into the chamber. Gloves are changed ~2X/yr and the catalyst containers are regenerated periodically when the chamber displays increasingly sluggish response to changes in oxygen levels. The chamber's pressure is controlled through one-way valves activated by solenoids. This feature is very convenient because it allows setting the chamber pressure at a level higher than the surroundings to allow transfer of very small tubes through the purge valve.

The anaerobic chambers can achieve levels of O₂ that can be reached that are consistently very low and are needed for highly oxygen sensitive anaerobic conditions. However, growth and handling of cells does not usually require such precautions. In an alternative anaerobic chamber

configuration, platinum or palladium can be used as a catalyst that requires some hydrogen gas in the mix. Instead of using solenoid valves, pressure release is controlled by a bubbler. Instead of using instrument-based O₂ monitoring, test strips can be used instead. To improve the anaerobic conditions a few relatively simple changes in our system can be made; some are already in progress.

Anaerobic microbiology. Small cultures are handled as described above for CO handling. In particular, serum or media bottles are fitted with thick rubber stoppers and aluminum crimps are employed to seal the bottle. Medium, such as Terrific Broth, is made in a conventional manner and dispensed to an appropriately sized serum bottle. The bottles are sparged with nitrogen for ~30 min of moderate bubbling. This removes most of the oxygen from the medium and, after this step; each bottle is capped with a rubber stopper (such as Bellco 20 mm septum stoppers; Bellco, Vineland, NJ) and crimp-sealed (Bellco 20 mm). Then the bottles of medium are autoclaved using a slow (liquid) exhaust cycle. At least sometimes a needle can be poked through the stopper to provide exhaust during autoclaving; the needle needs to be removed immediately upon removal from the autoclave. The sterile medium has the remaining medium components, for example buffer or antibiotics, added via syringe and needle. Prior to addition of reducing agents, the bottles are equilibrated for 30 - 60 minutes with nitrogen (or CO depending upon use). A reducing agent such as a 100 x 150 mM sodium sulfide, 200 mM cysteine-HCl can be added. This was made by weighing the sodium sulfide into a dry beaker and the cysteine into a serum bottle, bringing both into the anaerobic chamber, dissolving the sodium sulfide into anaerobic water, then adding this to the cysteine in the serum bottle. The bottle should be stoppered immediately as the sodium sulfide solution will generate hydrogen sulfide gas upon contact with the cysteine. When injecting into the culture, a syringe filter is used to sterilize the solution. Other components can be added through syringe needles, such as B12 (10 µM cyanocobalamin), nickel chloride (NiCl₂, 20 microM final concentration from a 40mM stock made in anaerobic water in the chamber and sterilized by autoclaving or by using a syringe filter upon injection into the culture), and ferrous ammonium sulfate (final concentration needed is 100 µM—made as 100-1000x stock solution in anaerobic water in the chamber and sterilized by autoclaving or by using a syringe filter upon injection into the culture). To facilitate faster growth under anaerobic conditions, the 1 l bottles were inoculated with 50 ml of a preculture grown anaerobically. Induction of the pA1-lacO1 promoter in the vectors was performed by

addition of isopropyl β -D-1-thiogalactopyranoside (IPTG) to a final concentration of 0.2 mM and was carried out for ~3 hrs.

- Large cultures can be grown in larger bottles using continuous gas addition while bubbling. A rubber stopper with a metal bubbler is placed in the bottle after medium addition and sparged with nitrogen for 30 minutes or more prior to setting up the rest of the bottle. Each bottle is put together such that a sterile filter will sterilize the gas bubbled in and the hoses on the bottles are compressible with small C clamps. Medium and cells are stirred with magnetic stir bars. Once all medium components and cells are added, the bottles can be incubated in an incubator in room air but with continuous nitrogen sparging into the bottles.
- 10 This example describes the handling of CO and anaerobic cultures.

EXAMPLE XV CO oxidation (CODH) Assay

This example describes assay methods for measuring CO oxidation (CO dehydrogenase; CODH).

- 15 The 7 gene CODH/ACS operon of *Moorella thermoacetica* was cloned into *E. coli* expression vectors. The intact ~10 kbp DNA fragment was cloned, and it is likely that some of the genes in this region are expressed from their own endogenous promoters and all contain endogenous ribosomal binding sites. *M. thermoacetica* is Gram positive, and ribosome binding site elements are expected to work well in *E. coli*. These clones were assayed for CO oxidation, using an assay that quantitatively measures CODH activity. Antisera to the *M. thermoacetica* gene products was used for Western blots to estimate specific activity. This activity, described below in more detail, was estimated to be ~1/50th of the *M. thermoacetica* specific activity.
- 20

- It is possible that CODH activity of recombinant *E. coli* cells could be limited by the fact that *M. thermoacetica* enzymes have temperature optima around 55°C. Therefore, a mesophilic CODH/ACS pathway could be advantageous such as the close relative of *Moorella* that is mesophilic and does have an apparently intact CODH/ACS operon and a Wood-Ljungdahl pathway, *Desulfotobacterium hafniense*. Acetogens as potential host organisms include, but are not limited to, *Rhodospirillum rubrum*, *Moorella thermoacetica* and *Desulfotobacterium hafniense*.
- 25

CO oxidation is both the most sensitive and most robust of the CODH/ACS assays. It is likely that an *E. coli*-based syngas using system will ultimately need to be about as anaerobic as *Clostridial* (i.e., *Moorella*) systems, especially for maximal activity. Improvement in CODH should be possible but will ultimately be limited by the solubility of CO gas in water.

- 5 Initially, each of the genes was cloned individually into expression vectors. Combined expression units for multiple subunits/1 complex were generated. Expression in *E. coli* at the protein level was determined. Both combined *M. thermoacetica* CODH/ACS operons and individual expression clones were made.

10 CO oxidation assay. This assay is one of the simpler, reliable, and more versatile assays of enzymatic activities within the Wood-Ljungdahl pathway and tests CODH (Seravalli et al., *Biochemistry* 43:3944-3955 (2004)). A typical activity of *M. thermoacetica* CODH specific activity is 500 U at 55°C or ~60U at 25°C. This assay employs reduction of methyl viologen in the presence of CO. This is measured at 578 nm in stoppered, anaerobic, glass cuvettes.

15 In more detail, glass rubber stoppered cuvettes were prepared after first washing the cuvette 4X in deionized water and 1X with acetone. A small amount of vacuum grease was smeared on the top of the rubber gasket. The cuvette was gassed with CO, dried 10 min with a 22 Ga. needle plus an exhaust needle. A volume of 0.98 ml of reaction buffer (50 mM HEPES, pH 8.5, 2mM dithiothreitol (DTT) was added using a 22 Ga. needle, with exhaust needed, and 100%CO. Methyl viologen (CH₃ viologen) stock was 1 M in water. Each assay used 20 microliters for 20
20 mM final concentration. When methyl viologen was added, an 18 Ga needle (partial) was used as a jacket to facilitate use of a Hamilton syringe to withdraw the CH₃ viologen. 4 -5 aliquots were drawn up and discarded to wash and gas equilibrate the syringe. A small amount of sodium dithionite (0.1 M stock) was added when making up the CH₃ viologen stock to slightly reduce the CH₃ viologen. The temperature was equilibrated to 55°C in a heated Olis spectrophotometer
25 (Bogart GA). A blank reaction (CH₃ viologen + buffer) was run first to measure the base rate of CH₃ viologen reduction. Crude *E. coli* cell extracts of ACS90 and ACS91 (CODH-ACS operon of *M. thermoacetica* with and without, respectively, the first *cooC*). 10 microliters of extract were added at a time, mixed and assayed. Reduced CH₃ viologen turns purple. The results of an assay are shown in Table X

Table 2. Crude extract CO Oxidation Activities.

ACS90	7.7 mg/ml	ACS91	11.8 mg/ml		
Mta98	9.8 mg/ml	Mta99	11.2 mg/ml		
<u>Extract</u>	<u>Vol</u>	<u>OD/</u>	<u>U/ml</u>	<u>U/mg</u>	
ACS90	10 microliters	0.073	0.376	0.049	
ACS91	10 microliters	0.096	0.494	0.042	
Mta99	10 microliters	0.0031	0.016	0.0014	
ACS90	10 microliters	0.099	0.51	0.066	
Mta99	25 microliters	0.012	0.025	0.0022	
ACS91	25 microliters	0.215	0.443	0.037	
Mta98	25 microliters	0.019	0.039	0.004	
ACS91	10 microliters	0.129	0.66	0.056	
Averages					
ACS90				0.057 U/mg	
ACS91				0.045 U/mg	
Mta99				0.0018 U/mg	

Mta98/Mta99 are *E. coli* MG1655 strains that express methanol methyltransferase genes from *M. thermoacetica* and, therefore, are negative controls for the ACS90 ACS91 *E. coli* strains that contain *M. thermoacetica* CODH operons.

If ~ 1% of the cellular protein is CODH, then these figures would be approximately 100X less than the 500 U/mg activity of pure *M. thermoacetica* CODH. Actual estimates based on Western blots are 0.5% of the cellular protein, so the activity is about 50X less than for *M. thermoacetica* CODH. Nevertheless, this experiment did clearly demonstrate CO oxidation activity in recombinant *E. coli* with a much smaller amount in the negative controls. The small amount of CO oxidation (CH₃ viologen reduction) seen in the negative controls indicates that *E. coli* may have a limited ability to reduce CH₃ viologen.

To estimate the final concentrations of CODH and Mtr proteins, SDS-PAGE followed by Western blot analyses were performed on the same cell extracts used in the CO oxidation, ACS, methyltransferase, and corrinoid Fe-S assays. The antisera used were polyclonal to purified *M. thermoacetica* CODH-ACS and Mtr proteins and were visualized using an alkaline phosphatase-linked goat-anti-rabbit secondary antibody. The Westerns were performed and results are shown in Figures 9A and 9B. The amounts of CODH in ACS90 and ACS91 were estimated at 50 ng by comparison to the control lanes. Expression of CODH-ACS operon genes including 2 CODH

subunits and the methyltransferase were confirmed via Western blot analysis. Therefore, the recombinant *E. coli* cells express multiple components of a 7 gene operon. In addition, both the methyltransferase and corrinoid iron sulfur protein were active in the same recombinant *E. coli* cells. These proteins are part of the same operon cloned into the same cells.

5 The CO oxidation assays were repeated using extracts of *Moorella thermoacetica* cells for the positive controls. Though CODH activity in *E. coli* ACS90 and ACS91 was measurable, it was at about 130 – 150 X lower than the *M. thermoacetica* control. The results of the assay are shown in Figure 10. Briefly, cells (*M. thermoacetica* or *E. coli* with the CODH/ACS operon; ACS90 or ACS91 or empty vector: pZA33S) were grown and extracts prepared as described
10 above. Assays were performed as described above at 55°C at various times on the day the extracts were prepared. Reduction of methylviologen was followed at 578 nm over a 120 sec time course.

These results describe the CO oxidation (CODH) assay and results. Recombinant *E. coli* cells expressed CO oxidation activity as measured by the methyl viologen reduction assay.

15

EXAMPLE XVI **Acetyl-CoA Synthase (ACS) Activity Assay (CO Exchange Assay)**

This example describes an ACS assay method.

This assay measures the ACS-catalyzed exchange of the carbonyl group of acetyl-CoA with CO (Raybuck et al., *Biochemistry* 27:7698-7702 (1988)). ACS (as either a purified enzyme or part
20 of a cell extract) is incubated with acetyl-CoA labeled with ¹⁴C at the carbonyl carbon under a CO atmosphere. In the presence of active ACS, the radioactivity in the liquid phase of the reaction decreases exponentially until it reaches a minimum defined by the equilibrium between the levels of ¹⁴C-labeled acetyl-CoA and ¹⁴C-labeled CO. The same cell extracts of *E. coli* MG1655 expressing ACS90 and ACS91 employed in the other assays as well as control extracts
25 were assayed by this method.

Briefly in more detail, in small assay vials under normal atmosphere, a solution of 0.2mM acetyl-CoA, 0.1mM methyl viologen, and 2mM Ti(III)citrate in 0.3M MES buffer, pH 6.0, was made. The total reaction volume when all components are added was 500 µl. Vials were sealed with rubber stoppers (Bellco) and crimp aluminum seals (Bellco) to create a gas-tight reaction
30 atmosphere. Each vial was sparged with 100% CO for several minutes, long enough to

completely exchange the vials' atmosphere, and brought into an anaerobic chamber. The assay vials were placed in a 55°C sand bath and allowed to equilibrate to that temperature. A total of 10 scintillation vials with 40 µl of 1M HCl were prepared for each assay vial. A gas-tight Hamilton syringe was used to add ACS to the assay vial and incubated for approximately 2-3 minutes for the reaction to come to equilibrium. A gas-tight Hamilton syringe was used to add 1 µl (0.36nmoles) ¹⁴C-acetyl-CoA to start the assay (time = 0 min). Time points were taken starting immediately. Samples (40 µl) were removed from the assay vials with a gas-tight Hamilton syringe. Each sample was added to the 40 µl of HCl in the prepared scintillation vials to quench the reaction. As the ACS enzyme transfers ¹⁴C label to CO from acetyl-CoA, the concentration of the isotope decreases exponentially. Therefore, the assay was sampled frequently in the early time points. The precise time for each sample was recorded. The exact pace of the reaction depends on the ACS enzyme, but generally several samples are taken immediately and sampled over the initial 10-15 minutes. Samples are continued to be taken for 1-2 hours.

In a particular exemplary assay, four assay conditions were used: blank (no ACS), 12 µl of purified *E. coli* strains expressing *M. thermoacetica* ACS, 4 µl of purified *E. coli* ACS, and 3.7 µl of *M. thermoacetica* CODH/ACS. In another exemplary assay, four assay conditions were used: 108 µg CODH/ACS, 1 mg Mta99 cell extract, 1 mg ACS90 cell extract, and 1 mg ACS91 cell extract. The enzymes were added as 100 µl solutions (50mM KPi, 0.1M NaCl, pH7.6). A more sensitive assay that can be used for most of the CODH-ACS activities is the synthesis assay described below.

This example describes the assay conditions for measuring ACS activity.

EXAMPLE XVII **Acetyl-CoA Synthesis and Methyltransferase Assays**

This example describes acetyl-CoA synthesis and methyltransferase assays.

Synthesis assay. This assay is an *in vitro* reaction that synthesizes acetyl-CoA from methyl-tetrahydrofolate, CO, and CoA using CODH/ACS, methyltransferase (MeTr), and corrinoid Fe-S protein (CFeSP) (Raybuck et al., *Biochemistry* 27:7698-7702 (1988)). By adding or leaving out each of the enzymes involved, this assay can be used for a wide range of experiments, from testing one or more purified enzymes or cell extracts for activity, to determining the kinetics of

the reaction under various conditions or with limiting amounts of substrate or enzyme. Samples of the reaction taken at various time points are quenched with 1M HCl, which liberates acetate from the acetyl-CoA end product. After purification with Dowex columns, the acetate can be analyzed by chromatography, mass spectrometry, or by measuring radioactivity. The exact method will be determined by the specific substrates used in the reaction.

A ^{14}C -labeled methyl-THF was utilized, and the radioactivity of the isolated acetate samples was measured. The primary purpose was to test CFeSP subunits. The assay also included +/- purified methyltransferase enzymes. The following 6 different conditions were assayed: (1) purified CODH/ACS, MeTr, and CFeSP as a positive control; (2) purified CODH/ACS with ACS90 cell extract; (3) purified CODH/ACS with ACS91 cell extract; (4) purified CODH/ACS, MeTr with ACS90 cell extract; (5) purified CODH/ACS, MeTr with ACS91 cell extract; (6) purified CODH/ACS, MeTr with as much ACS91 cell extract as possible (excluding the MES buffer).

The reaction is assembled in the anaerobic chamber in assay vials that are filled with CO. The total reaction volume is small compared to the vial volume, so the reagents can be added before or after the vial is filled with CO, so long as a gas-tight Hamilton syringe is used and the reagents are kept anaerobic. The reaction (~60ul total) consisted of the cell extract (except assay #1), CoA, Ti(III)citrate, MES (except assay #6), purified CODH/ACS, ^{14}C -methyl-tetrahydrofolate, methyl-viologen, and ferredoxin. Additionally, purified MeTr was added to assays #1 and #4-6, and purified CFeSP was added to assay #1.

The reaction was carried out in an anaerobic chamber in a sand bath at 55°C. The final reagent added was the ^{14}C -methyl-tetrahydrofolate, which started the reaction ($t = 0\text{s}$). An initial sample was taken immediately, followed by samples at 30 minutes, 1 hour, and 2 hours. These time points are not exact, as the 6 conditions were run concurrently (since this experiment was primarily a qualitative one). The 15 μl samples were added to 15 μl of 1M HCl in scintillation vials. For the last sample, if less than 15 μl was left in the reactions, the assay vials were rinsed with the 15ul of HCl to take the remainder of the reaction. A volume of 10 μl of cell extract was used for assay #2-5, and 26.4 μl of cell extract was used for assay #6.

Typical amounts of purified enzyme to be used in the assays is as follows: CODH/ACS = ~0.2 nmoles; MeTr = 0.2 nmoles; CFeSP = 0.05 nmoles. Typical assay concentrations are used as follows: CODH/ACS = 1uM; Me-CFeSP = 0.4uM; MeTr = 1uM; Ferredoxin = 3uM; CoA = 0.26mM; ¹⁴C methyl-THF = 0.4mM; methyl viologen = 0.1mM; and Ti(III)citrate = 3mM.

- 5 After counting the reaction mixtures, it was determined that the corrinoid Fe-S protein in ACS90 extracts was active with total activity approaching approximately 1/5 of the positive control and significantly above the negative control (no extract).

A non-radioactive synthesis assay can also be used. Optional non-radioactive assay conditions are as follows: Assay condition #1: 100mM MES, pH6.0; 1mM CoA; 1mM Me-THF; 0.33mM
10 Ti(III) citrate, volume to 950ul, +50ul of extract; incubated under a CO atmosphere (Ar for control), at 55°C. These reactions should be carried out in the dark, as the corrinoid methyl carrier is light sensitive. Assay condition #2: 100mM MES, pH6.0; 1mM CoA; 1mM Me-THF; 1mM methyl viologen; volume to 950ul, +50ul of extract; incubated under a CO atmosphere, at 55°C, in the dark. The reaction was quenched with 10 µl of 10% formic acid, with samples taken
15 at 1hr, 3hrs, and 6.5hrs, and stored at -20°. Assay condition #3: 100mM Tris, pH 7.6; 5mM CoA; 7.5mM Me-THF; 1 mM Me-viologen; volume to 90 µl, +10 µl extract; incubated under CO or Ar, at 55°C in the dark for 1hr, quenched with 10 µl 10% formic acid, and stored at -20°C.

In Lu et al., (*J. Biol. Chem.* 265:3124-3133.(1990)), the pH optimum for the synthesis reaction was found to be between 7.2-7.5. Lu et al. also found that CoA concentrations above 10mM
20 were inhibitory. Lu et al. described using methyl iodide as the methyl donor instead of Me-THF, and used 5-7.5mM concentrations. Lu et al. also determined that DTT or other reducing agents were not necessary, although they did use ferredoxin as an electron carrier. Methyl viologen was substituted in the above-described reactions. In addition, Maynard et al., *J. Biol. Inorg. Chem.* 9:316-322 (2004), has determined that the electron carrier was not strictly necessary, but that
25 failure to include one resulted in a time lag of the synthesis. Maynard et al. used 1mM methyl viologen as electron carrier when one was used.

Methyltransferase Assay. Within the CODH-ACS operon is encoded an essential methyltransferase activity that catalyzes the transfer of CH₃ from methyl-tetrahydrofolate to the ACS complex as part of the synthesis of acetyl-CoA. This is the step that the methyl and
30 carbonyl pathways join together. Within the operon in *M. thermoacetica*, the Mtr-encoding gene

is Moth_1197 and comes after the main CODH and ACS subunits. Therefore, Mtr activity would constitute indirect evidence that the more proximal genes can be expressed.

Mtr activity was assayed by spectroscopy. Specifically, methylated CFeSP, with Co(III), has a small absorption peak at ~450nm, while non-methylated CFeSP, with Co(I), has a large peak at
5 ~390nm. This spectrum is due to both the cobalt and iron-sulfur cluster chromophores. Additionally, the CFeSP can spontaneously oxidize to Co(II), which creates a broad absorption peak at ~470nm (Seravalli et al., *Biochemistry* 38:5728-5735 (1999)). Recombinant methyltransferase is tested using *E. coli* cell extracts, purified CFeSP from *M. thermoacetica*, and methyl-tetrahydrofolate. The methylation of the corrinoid protein is observed as a decrease
10 in the absorption at 390nm with a concurrent increase in the absorption at 450nm, along with the absence of a dominant peak at 470nm.

Non-radioactive assays are also being developed using ¹³C-methanol. This should transfer to tetrahydrofolate and create a MTHF of molecular mass +1. Alternatively, the methyltransferase is thought to also work by transfer of the methanol methyl group to homocysteine to form
15 methionine. This assay is also useful because methionine +1 mass is more readily detectable than MTHF + 1 or some other possibilities. In addition to using ¹³C, deuterium can also be used as a tracer, both of which can be measured using mass spectrometry. These tracers can also be used in *in vivo* labeling studies. Other assay methods can be used to determine various intermediates or products including, for example, electron paramagnetic resonance (EPR),
20 Mossbauer spectroscopy, Electron-Nuclear DOuble Resonance (ENDOR), infrared, magnetic circular dichroism (MCD), crystallography, X-ray absorption, as well as kinetic methods, including stopped flow and freeze-quench EPR.

Figure 8 illustrates how methanol methyltransferase can be fitted into a CODH/ACS ('syngas') pathway. Essentially, the methyl group of methanol is transferred via a cobalamin-dependent
25 process to tetrahydrofolate and then to the corrinoid-FeS protein of CODH/ACS (also a cobalamin protein) and that, in turn, donates the methyl group to the ACS reaction that results in acetate synthesis. The methanol methyltransferase complex consists of three gene products; two of these, MtaB and MtaC, (Moth_1209 and Moth_1208) are adjacent and were readily cloned. The third, MtaA, may be encoded by three different genes (Moth_2100, Moth_2102, and
30 Moth_2346), and it unclear whether all three genes are required or whether a subset of the three

can function. All cloning in *E. coli* was performed using the Lutz-Bujard vectors (Lutz and Bujard, *Nucleic Acids Res.* 25:1203-1210 (1997)).

The following assay can be used to determine the activity of MtaB that encodes a methanol methyltransferase gene product. A positive control for the latter can be performed with vanillate
5 o-demethylation.

Methanol Methyltransferase reaction. An exemplary methanol methyl-transfer reaction has been described previously (Sauer and Thauer, *Eur. J. Biochem.* 249:280-285 (1997); Naidu and Ragsdale, *J. Bacteriol.* 183:3276-3281 (2001)). The reaction conditions are as follows: 50mM MOPS/KOH, pH 7.0; 10 mM MgCl₂; 4 mM Ti(III) citrate; 0.2% dodecylmaltoside (replacing
10 SDS, see Sauer and. Thauer, *Eur. J. Biochem.* 253:698-705 (1998)); 25 μM hydroxycobalamin; 1% MeOH or 1mM vanillate (depending on the methyl transferase version).

These reactions are measured by spectrograph readings in the dark at 37°C or 55°C. This assay tests the ability of MtaB or MtvB to transfer the methyl group to cobalamin from methanol or vanillate, respectively.

15

EXAMPLE XVIII

E. coli CO Tolerance Experiment and CO Concentration Assay (myoglobin assay)

This example describes the tolerance of *E. coli* for high concentrations of CO.

To test whether or not *E. coli* can grow anaerobically in the presence of saturating amounts of CO, cultures were set up in 120 ml serum bottles with 50 ml of Terrific Broth medium (plus
20 reducing solution, NiCl₂, Fe(II)NH₄SO₄, cyanocobalamin, IPTG, and chloramphenicol) as described above for anaerobic microbiology in small volumes. One half of these bottles were equilibrated with nitrogen gas for 30 min. and one half was equilibrated with CO gas for 30 min. An empty vector (pZA33) was used as a control, and cultures containing the pZA33 empty vector as well as both ACS90 and ACS91 were tested with both N₂ and CO. All were inoculated
25 and grown for 36 hrs with shaking (250 rpm) at 37°C. At the end of the 36 hour period, examination of the flasks showed high amounts of growth in all. The bulk of the observed growth occurred overnight with a long lag.

Given that all cultures appeared to grow well in the presence of CO, the final CO concentrations were confirmed. This was performed using an assay of the spectral shift of myoglobin upon exposure to CO. Myoglobin reduced with sodium dithionite has an absorbance peak at 435 nm; this peak is shifted to 423 nm with CO. Due to the low wavelength and need to record a whole spectrum from 300 nm on upwards, quartz cuvettes must be used. CO concentration is measured against a standard curve and depends upon the Henry's Law constant for CO of maximum water solubility = 970 micromolar at 20°C and 1 atm.

For the myoglobin test of CO concentration, cuvettes were washed 10X with water, 1X with acetone, and then stoppered as with the CODH assay. N₂ was blown into the cuvettes for ~10 min. A volume of 1 ml of anaerobic buffer (HEPES, pH 8.0, 2mM DTT) was added to the blank (not equilibrated with CO) with a Hamilton syringe. A volume of 10 microliter myoglobin (~1 mM—can be varied, just need a fairly large amount) and 1 microliter dithionite (20 mM stock) were added. A CO standard curve was made using CO saturated buffer added at 1 microliter increments. Peak height and shift was recorded for each increment. The cultures tested were pZA33/CO, ACS90/CO, and ACS91/CO. each of these was added in 1 microliter increments to the same cuvette. Midway through the experiment a second cuvette was set up and used. The results are shown in Table 3.

Table 3. Carbon Monoxide Concentrations, 36 hrs.

<u>Strain and Growth Conditions</u>	<u>Final CO concentration (micromolar)</u>
pZA33-CO	930
ACS90-CO	638
	494
	734
	883
ave	687
SD	164
ACS91-CO	728
	812
	760
	611
ave.	728
SD	85

The results shown in Table 3 indicate that the cultures grew whether or not a strain was cultured in the presence of CO or not. These results indicate that *E. coli* can tolerate exposure to CO under anaerobic conditions and that *E. coli* cells expressing the CODH-ACS operon can metabolize some of the CO.

These results demonstrate that *E. coli* cells, whether expressing CODH/ACS or not, were able to grow in the presence of saturating amounts of CO. Furthermore, these grew equally well as the controls in nitrogen in place of CO. This experiment demonstrated that laboratory strains of *E. coli* are insensitive to CO at the levels achievable in a syngas project performed at normal atmospheric pressure. In addition, preliminary experiments indicated that the recombinant *E. coli* cells expressing CODH/ACS actually consumed some CO, probably by oxidation to carbon dioxide.

EXAMPLE IX

Exemplary Pathways for Production of 4-Hydroxybutyrate and 1,4-Butanediol

This example describes exemplary pathways for the production of 4-hydroxybutyrate and 1,4-butanediol from acetyl-CoA.

As disclosed herein, the combination of (1) pathways for the conversion of synthesis gases with and without methanol to acetyl-CoA and (2) pathways for the conversion of acetyl-CoA to 4-hydroxybutyrate, or 1,4-butanediol. As such, this invention provides production organisms and conversion routes with inherent yield advantages over organisms engineered to produce 4-hydroxybutyrate, or 1,4-butanediol from carbohydrate feedstocks. For example, the maximum theoretical yields of 4-hydroxybutyrate, and 1,4-butanediol from glucose are 1 mole per mole using the metabolic pathways proceeding from acetyl-CoA as described herein. Specifically, 2 moles of acetyl-CoA are derived per mole of glucose via glycolysis and 2 moles of acetyl-CoA are required per mole of 4-hydroxybutyrate, or 1,4-butanediol. The net conversions are described by the following stoichiometric equations:

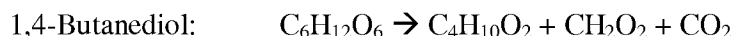
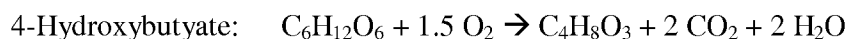

On the other hand, gasification of glucose to its more simpler components, CO and H₂, followed by their conversion to 4-hydroxybutyrate, and 1,4-butanediol using the pathways described herein results in the following maximum theoretical yields:

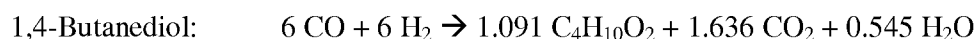
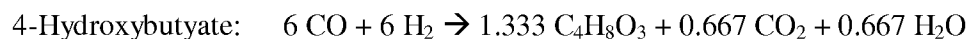

Note that the gasification of glucose can at best provide 6 moles of CO and 6 moles of H₂. The maximum theoretical yields of 4-hydroxybutyrate, and 1,4-butanediol from synthesis gases can be further enhanced by the addition of methanol as described below:

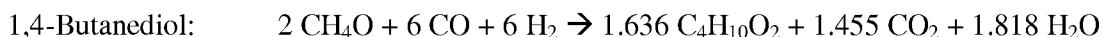
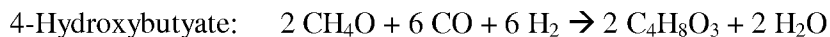
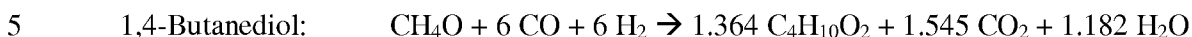
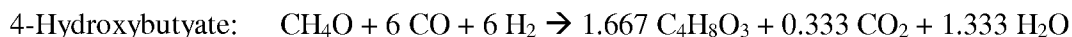

Thus it is clear that the organisms and conversion routes described herein provide an efficient means of converting carbohydrates to 4-hydroxybutyrate, or 1,4-butanediol.

- 10 Acetoacetyl-CoA thiolase converts two molecules of acetyl-CoA into one molecule each of acetoacetyl-CoA and CoA. Exemplary acetoacetyl-CoA thiolase enzymes include the gene products of *atoB* from *E. coli* (Martin et al., Nat.Biotechnol 21:796-802 (2003)), *thlA* and *thlB* from *C. acetobutylicum* (Hanai et al., Appl Environ Microbiol 73:7814-7818 (2007); Winzer et al., J.Mol.Microbiol Biotechnol 2:531-541 (2000), and *ERG10* from *S. cerevisiae* Hiser et al.,
15 J.Biol.Chem. 269:31383-31389 (1994)).

<u>Protein</u>	<u>GenBank ID</u>	<u>Organism</u>
<i>AtoB</i>	NP_416728	<i>Escherichia coli</i>
<i>ThlA</i>	NP_349476.1	<i>Clostridium acetobutylicum</i>
<i>ThlB</i>	NP_149242.1	<i>Clostridium acetobutylicum</i>
<i>ERG10</i>	NP_015297	<i>Saccharomyces cerevisiae</i>

- Exemplary 3-hydroxyacyl dehydrogenases which convert acetoacetyl-CoA to 3-hydroxybutyryl-CoA include *hbd* from *C. acetobutylicum* (Boynton et al., Journal of Bacteriology 178:3015-
20 3024 (1996)), *hbd* from *C. beijerinckii* (Colby and Chen et al., Appl Environ.Microbiol 58:3297-3302 (1992)), and a number of similar enzymes from *Metallosphaera sedula* (Berg et al., 2007 Science 318:1782-1786 (2007)).

<u>Protein</u>	<u>GenBank ID</u>	<u>Organism</u>
<i>hbd</i>	NP_349314.1	<i>Clostridium acetobutylicum</i>
<i>hbd</i>	AAM14586.1	<i>Clostridium beijerinckii</i>
<i>Msed_1423</i>	YP_001191505	<i>Metallosphaera sedula</i>
<i>Msed_0399</i>	YP_001190500	<i>Metallosphaera sedula</i>
<i>Msed_0389</i>	YP_001190490	<i>Metallosphaera sedula</i>
<i>Msed_1993</i>	YP_001192057	<i>Metallosphaera sedula</i>

The gene product of *crt* from *C. acetobutylicum* catalyzes the dehydration of 3-hydroxybutyryl-CoA to crotonyl-CoA (Atsumi et al., Metab Eng (2007); Boynton et al., Journal of Bacteriology 178:3015-3024 (1996)). Further, enoyl-CoA hydratases are reversible enzymes and thus suitable candidates for catalyzing the dehydration of 3-hydroxybutyryl-CoA to crotonyl-CoA. The enoyl-CoA hydratases, *phaA* and *phaB*, of *P. putida* are believed to carry out the hydroxylation of double bonds during phenylacetate catabolism (Olivera et al., Proc Nat Acad Sci U.S.A. 95:6419-6424 (1998)). The *paaA* and *paaB* from *P. fluorescens* catalyze analogous transformations (Olivera et al., Proc Nat Acad Sci U.S.A. 95:6419-6424 (1998)). Lastly, a number of *Escherichia coli* genes have been shown to demonstrate enoyl-CoA hydratase functionality including *maoC*, *paaF*, and *paaG* (Ismail et al., European Journal of Biochemistry 270:3047-3054 (2003); Park and Lee, J Bacteriol. 185:5391-5397 (2003); Park and Lee, Appl Biochem. Biotechnol 113-116:335-346 (2004); Park and Yup, Biotechnol Bioeng 86:681-686 (2004)).

<u>Protein</u>	<u>GenBank ID</u>	<u>Organism</u>
<i>crt</i>	NP_349318.1	<i>Clostridium acetobutylicum</i>
<i>paaA</i>	NP_745427.1	<i>Pseudomonas putida</i>
<i>paaB</i>	NP_745426.1	<i>Pseudomonas putida</i>
<i>phaA</i>	ABF82233.1	<i>Pseudomonas fluorescens</i>
<i>phaB</i>	ABF82234.1	<i>Pseudomonas fluorescens</i>
<i>maoC</i>	NP_415905.1	<i>Escherichia coli</i>
<i>paaF</i>	NP_415911.1	<i>Escherichia coli</i>
<i>paaG</i>	NP_415912.1	<i>Escherichia coli</i>

Several enzymes that naturally catalyze the reverse reaction (i.e., the dehydration of 4-hydroxybutyryl-CoA to crotonoyl-CoA) *in vivo* have been identified in numerous species. This transformation is used for 4-aminobutyrate fermentation by *Clostridium aminobutyricum* (Scherf and Buckel, Eur.J Biochem. 215:421-429 (1993)) and succinate-ethanol fermentation by

Clostridium kluyveri (Scherf et al., Arch.Microbiol 161:239-245 (1994)). The transformation is also a step in Archaea, for example, *Metallosphaera sedula*, as part of the 3-hydroxypropionate/4-hydroxybutyrate autotrophic carbon dioxide assimilation pathway (Berg et al., Science 318:1782-1786 (2007)). This pathway uses the hydration of crotonoyl-CoA to form 4-hydroxybutyryl-CoA. The reversibility of 4-hydroxybutyryl-CoA dehydratase is well-
 5 documented (Friedrich et al., Angew.Chem.Int.Ed.Engl. 47:3254-3257 (2008); Muh et al., Eur.J.Biochem. 248:380-384 (1997); Muh et al., Biochemistry 35:11710-11718 (1996)) and the equilibrium constant has been reported to be about 4 on the side of crotonoyl-CoA (Scherf and Buckel, Eur.J Biochem. 215:421-429 (1993)). This indicates that the downstream 4-
 10 hydroxybutyryl-CoA dehydrogenase keeps the 4-hydroxybutyryl-CoA concentration low so as to not create a thermodynamic bottleneck at crotonoyl-CoA.

<u>Protein</u>	<u>GenBank ID</u>	<u>Organism</u>
<i>AbfD</i>	CAB60035	<i>Clostridium aminobutyricum</i>
<i>AbfD</i>	YP_001396399	<i>Clostridium kluyveri</i>
<i>Msed_1321</i>	YP_001191403	<i>Metallosphaera sedula</i>
<i>Msed_1220</i>	YP_001191305	<i>Metallosphaera sedula</i>

4-Hydroxybutyryl-CoA transferase transfers the CoA moiety from 4-hydroxybutyryl-CoA to
 15 acetate, in turn, forming 4-hydroxybutyrate and acetyl-CoA. One exemplary 4-hydroxybutyryl-CoA transferase is encoded by the *cat2* gene of *Clostridium kluyveri* (Seedorf et al., Proc.Natl.Acad.Sci.U S.A. 105:2128-2133 (2008); Sohling and Gottschalk J Bacteriol. 178:871-880 (1996)). The *abfT-2* gene from *Porphyromonas gingivalis* was also shown to exhibit 4-hydroxybutyryl-CoA transferase activity when implemented as part of a pathway to produce 4-
 20 hydroxybutyrate and 1,4-butanediol (Burk, et al., WO/2008/115840 (2008)).

An additional candidate enzyme, encoded by *abfT-1*, from *P. gingivalis* can be inferred by sequence homology. Another 4-hydroxybutyryl-CoA transferase is encoded by the gene product of *abfT* from *Clostridium aminobutyricum* (Gerhardt et al., Arch.Microbiol 174:189-199 (2000)).

<u>Protein</u>	<u>GenBank ID</u>	<u>Organism</u>
<i>cat2</i>	YP_001396397	<i>Clostridium kluyveri</i>
<i>abfT-2</i>	NP_906037	<i>Porphyromonas gingivalis</i>
<i>abfT-1</i>	NP_904965.1	<i>Porphyromonas gingivalis</i>
<i>abfT</i>	CAB60036	<i>Clostridium aminobutyricum</i>

Exemplary phosphate transferring acyltransferases include phosphotransacetylase, encoded by *pta*, and phosphotransbutyrylase, encoded by *ptb*. The *pta* gene from *E. coli* encodes an enzyme that can convert acetyl-CoA into acetyl-phosphate, and vice versa (Suzuki, T. 1969

5 Biochim.Biophys.Acta 191:559-569 (1969)). This enzyme can also utilize propionyl-CoA instead of acetyl-CoA forming propionate in the process (Hesslinger et al., Mol.Microbiol 27:477-492 (1998)). Similarly, the *ptb* gene from *C. acetobutylicum* encodes an enzyme that can convert butyryl-CoA into butyryl-phosphate (Huang et al., J.Mol.Microbiol Biotechnol 2:33-38 (2000); (Walter et al., Gene 134:107-111 (1993)). This same enzyme was shown to have activity

10 on 4-hydroxybutyryl-CoA when implemented as part of a pathway to produce 1,4-butanediol WO/2008/115840 (2008). Additional *ptb* genes can be found in butyrate-producing bacterium L2-50 (Ljungdahl and Andreesen, Methods Enzymol. 53:360-372 (1978) and *Bacillus megaterium* (Vazquez et al., Curr.Microbiol 42:345-349 (2001)).

<u>Protein</u>	<u>GenBank ID</u>	<u>Organism</u>
<i>pta</i>	NP_416800.1	<i>Escherichia coli</i>
<i>ptb</i>	NP_349676	<i>Clostridium acetobutylicum</i>
<i>ptb</i>	AAR19757.1	butyrate-producing bacterium L2-50
<i>ptb</i>	CAC07932.1	<i>Bacillus megaterium</i>

15 Exemplary kinases include the *E. coli* acetate kinase, encoded by *ackA* (Skarstedt and Silverstein, J.Biol.Chem.251:6775-6783 (1976)), the *C. acetobutylicum* butyrate kinases, encoded by *buk1* and *buk2* (Huang et al., 2000 J.Mol.Microbiol Biotechnol 2:33-38 (2000); Walter et al., Gene 134:107-111 (1993)), and the *E. coli* gamma-glutamyl kinase, encoded by

20 *proB* (Smith et al., J.Bacteriol. 157:545-551 (1984)). These enzymes phosphorylate acetate, butyrate, and glutamate, respectively. The *ackA* gene product from *E. coli* also phosphorylates propionate (Hesslinger et al., Mol.Microbiol 27:477-492 (1998)). The gene product of *buk1* from *C. acetobutylicum* was shown in Burk et al., WO/2008/115840 (2008) to have activity on 4-

25

<u>Protein</u>	<u>GenBank ID</u>	<u>Organism</u>
<i>ackA</i>	NP_416799.1	<i>Escherichia coli</i>
<i>buk1</i>	NP_349675	<i>Clostridium acetobutylicum</i>
<i>buk2</i>	Q97H11	<i>Clostridium acetobutylicum</i>
<i>proB</i>	NP_414777.1	<i>Escherichia coli</i>

Alcohol-forming 4-hydroxybutyryl-CoA reductase enzymes catalyze the 2 reduction steps required to form 1,4-butanediol from 4-hydroxybutyryl-CoA. Exemplary 2-step oxidoreductases that convert an acyl-CoA to alcohol include those that transform substrates such as acetyl-CoA to ethanol (e.g., *adhE* from *E. coli* (Kessler et al., FEBS.Lett. 281:59-63 (1991)) and butyryl-CoA to butanol (e.g. *adhE2* from *C. acetobutylicum* (Fontaine et al., J.Bacteriol. 184:821-830 (2002))). The *adhE2* enzyme from *C. acetobutylicum* was specifically shown in ref. Burk et al., WO/2008/115840 (2008). to produce BDO from 4-hydroxybutyryl-CoA. In addition to reducing acetyl-CoA to ethanol, the enzyme encoded by *adhE* in *Leuconostoc mesenteroides* has been shown to oxidize the branched chain compound isobutyraldehyde to isobutyryl-CoA (Kazahaya et al., J.Gen.Appl.Microbiol. 18:43-55 (1972); Koo et al., Biotechnol Lett. 27:505-510 (2005)).

<u>Protein</u>	<u>GenBank ID</u>	<u>Organism</u>
<i>adhE</i>	NP_415757.1	<i>Escherichia coli</i>
<i>adhE2</i>	AAK09379.1	<i>Clostridium acetobutylicum</i>
<i>adhE</i>	AAV66076.1	<i>Leuconostoc mesenteroides</i>

Another exemplary enzyme can convert malonyl-CoA to 3-HP. An NADPH-dependent enzyme with this activity has characterized in *Chloroflexus aurantiacus* where it participates in the 3-hydroxypropionate cycle (Hugler et al., J.Bacteriol. 184:2404-2410 (2000); Strauss and Fuchs, Eur.J.Biochem. 215:633-643 (1993)). This enzyme, with a mass of 300 kDa, is highly substrate-specific and shows little sequence similarity to other known oxidoreductases (Hugler et al., J.Bacteriol. 184:2404-2410 (2002)). No enzymes in other organisms have been shown to catalyze this specific reaction; however there is bioinformatic evidence that other organisms may have similar pathways (Klatt et al., Environ.Microbiol. 9:2067-2078 (2007)). Enzyme candidates in other organisms including *Roseiflexus castenholzii*, *Erythrobacter sp. NAPI* and marine gamma proteobacterium HTCC2080 can be inferred by sequence similarity.

<u>Protein</u>	<u>GenBank ID</u>	<u>Organism</u>
<i>mcr</i>	AAS20429.1	<i>Chloroflexus aurantiacus</i>
<i>Rcas_2929</i>	YP_001433009.1	<i>Roseiflexus castenholzii</i>
<i>NAPI_02720</i>	ZP_01039179.1	<i>Erythrobacter sp. NAPI</i>
MGP2080_00535	ZP_01626393.1	marine gamma proteobacterium HTCC2080

An alternative route to BDO from 4-hydroxybutyryl-CoA involves first reducing this compound to 4-hydroxybutanal. Several acyl-CoA dehydrogenases are capable of reducing an acyl-CoA to its corresponding aldehyde. Exemplary genes that encode such enzymes include the

- 5 *Acinetobacter calcoaceticus* *acrI* encoding a fatty acyl-CoA reductase (Reiser and Somerville, Journal of Bacteriology 179:2969-2975 (1997)), the *Acinetobacter sp. M-1* fatty acyl-CoA reductase (Ishige et al., Appl. Environ. Microbiol. 68:1192-1195 (2002)), and a CoA- and NADP-dependent succinate semialdehyde dehydrogenase encoded by the *sucD* gene in *Clostridium kluyveri* (Sohling and Gottschalk, J Bacteriol. 178:871-880 (1996)). *SucD* of *P. gingivalis* is
- 10 another succinate semialdehyde dehydrogenase (Takahashi et al., J. Bacteriol. 182:4704-4710 (2000)). These succinate semialdehyde dehydrogenases were specifically shown in ref. Burk et al., WO/2008/115840 (2008) to convert 4-hydroxybutyryl-CoA to 4-hydroxybutanal as part of a pathway to produce 1,4-butanediol. The enzyme acylating acetaldehyde dehydrogenase in
- 15 *Pseudomonas sp.*, encoded by *bphG*, is yet another capable enzyme as it has been demonstrated to oxidize and acylate acetaldehyde, propionaldehyde, butyraldehyde, isobutyraldehyde and formaldehyde (Powlowski et al., J Bacteriol. 175:377-385 (1993)).

<u>Protein</u>	<u>GenBank ID</u>	<u>Organism</u>
<i>acrI</i>	YP_047869.1	<i>Acinetobacter calcoaceticus</i>
<i>acrI</i>	AAC45217	<i>Acinetobacter baylyi</i>
<i>acrI</i>	BAB85476.1	<i>Acinetobacter sp. Strain M-1</i>
<i>sucD</i>	P38947.1	<i>Clostridium kluyveri</i>
<i>sucD</i>	NP_904963.1	<i>Porphyromonas gingivalis</i>
<i>bphG</i>	BAA03892.1	<i>Pseudomonas sp</i>

- An additional enzyme type that converts an acyl-CoA to its corresponding aldehyde is malonyl-
- 20 CoA reductase which transforms malonyl-CoA to malonic semialdehyde. Malonyl-CoA reductase is a key enzyme in autotrophic carbon fixation via the 3-hydroxypropionate cycle in thermoacidophilic archaeal bacteria (Berg et al., Science 318:1782-1786 (2007); Thauer, R. K. Science 318:1732-1733 (2007)). The enzyme utilizes NADPH as a cofactor and has been

characterized in *Metallosphaera* and *Sulfolobus spp* (Alber et al., J.Bacteriol.188:8551-8559 (2006); Hugler et al., J.Bacteriol. 184:2404-2410 (2002)). The enzyme is encoded by *Msed_0709* in *Metallosphaera sedula* (Alber et al., J.Bacteriol. 188:8551-8559 (2006); Berg et al., Science 318:1782-1786 (2007)). A gene encoding a malonyl-CoA reductase from *Sulfolobus tokodaii* was cloned and heterologously expressed in *E. coli* (Alber et al., J.Bacteriol. 188:8551-8559 (2006)). Although the aldehyde dehydrogenase functionality of these enzymes is similar to the bifunctional dehydrogenase from *Chloroflexus aurantiacus*, there is little sequence similarity. Both malonyl-CoA reductase enzyme candidates have high sequence similarity to aspartate-semialdehyde dehydrogenase, an enzyme catalyzing the reduction and concurrent dephosphorylation of aspartyl-4-phosphate to aspartate semialdehyde. Additional gene candidates can be found by sequence homology to proteins in other organisms including *Sulfolobus solfataricus* and *Sulfolobus acidocaldarius*.

<u>Protein</u>	<u>GenBank ID</u>	<u>Organism</u>
<i>Msed_0709</i>	YP_001190808.1	<i>Metallosphaera sedula</i>
<i>mcr</i>	NP_378167.1	<i>Sulfolobus tokodaii</i>
<i>asd-2</i>	NP_343563.1	<i>Sulfolobus solfataricus</i>
<i>Saci_2370</i>	YP_256941.1	<i>Sulfolobus acidocaldarius</i>

Enzymes exhibiting 1,4-butanediol dehydrogenase activity are capable of forming 1,4-butanediol from 4-hydroxybutanal. Exemplary genes encoding enzymes that catalyze the conversion of an aldehyde to alcohol (i.e., alcohol dehydrogenase or equivalently aldehyde reductase) include *alrA* encoding a medium-chain alcohol dehydrogenase for C2-C14 (Tani et al., Appl.Environ.Microbiol. 66:5231-5235 (2000)), *ADH2* from *Saccharomyces cerevisiae* Atsumi et al. Nature 451:86-89 (2008)), *yqhD* from *E. coli* which has preference for molecules longer than C(3) (Sulzenbacher et al., Journal of Molecular Biology 342:489-502 (2004)), and *bdh I* and *bdh II* from *C. acetobutylicum* which converts butyrylaldehyde into butanol (Walter et al., Journal of Bacteriology 174:7149-7158 (1992)).

<u>Protein</u>	<u>GenBank ID</u>	<u>Organism</u>
<i>alrA</i>	BAB12273.1	<i>Acinetobacter sp.</i> Strain M-1
<i>ADH2</i>	NP_014032.1	<i>Saccharomyces cerevisiae</i>
<i>yqhD</i>	NP_417484.1	<i>Escherichia coli</i>
<i>bdh I</i>	NP_349892.1	<i>Clostridium acetobutylicum</i>
<i>bdh II</i>	NP_349891.1	<i>Clostridium acetobutylicum</i>

Enzymes exhibiting 4-hydroxybutyrate dehydrogenase activity (EC 1.1.1.61) also fall into this category. Such enzymes have been characterized in *Ralstonia eutropha* (Bravo et al., *J. Forensic Sci.* 49:379-387 (2004)), *Clostridium kluyveri* (Wolff and Kenealy, *Protein Expr. Purif.* 6:206-212 (1995)) and *Arabidopsis thaliana* (Breitkreuz et al., *J. Biol. Chem.* 278:41552-41556 (2003)).

5

<u>Protein</u>	<u>GenBank ID</u>	<u>Organism</u>
<i>4hbd</i>	YP_726053.1	<i>Ralstonia eutropha</i> H16
<i>4hbd</i>	L21902.1	<i>Clostridium kluyveri</i> DSM 555
<i>4hbd</i>	Q94B07	<i>Arabidopsis thaliana</i>

The nonnative genes needed for 4-hydroxybutyrate synthesis are cloned on expression plasmids as described previously. The host strain also expresses methanol methyltransferase activity, CODH/ACS activity, and possibly PFOR and hydrogenase activities. At this point, these (CODH/ACS, etc.) genes are integrated into the genome and expressed from promoters that can be used constitutively or with inducers (i.e., PA1-lacO1 is inducible in cells containing *lacI* or is otherwise constitutive). Once expression and yields of 4-hydroxybutyrate are optimized, the base strain is further modified by integration of a single copy of these genes at a neutral locus. Given the relatively limited number of genes (at minimum, 5, and at most, 6), an artificial operon encoding the required genes can be constructed. This operon is introduced using integrative plasmids and is coupled to counter-selection methods such as that allowed by the *Bacillus sacB* gene (Link et al., *J. Bacteriol.* 179:6228-6237 (1997)). In this way, markerless and scar less insertions at any location in the *E. coli* chromosome can be generated. Optimization involves altering gene order as well as ribosomal binding sites and promoters.

The nonnative genes needed for 1,4-butanediol synthesis are cloned on expression plasmids as described previously. The host strain also expresses methanol methyltransferase activity, CODH/ACS activity, and possibly PFOR and hydrogenase activities. At this point, these (CODH/ACS, etc.) genes are integrated into the genome and expressed from promoters that can be used constitutively or with inducers (i.e., PA1-lacO1 is inducible in cells containing *lacI* or is otherwise constitutive). Once expression and yields of 1,4-butanediol are optimized, the base strain is further modified by integration of a single copy of these genes at a neutral locus. Given the relatively limited number of genes (at minimum, 5, and at most, 6), an artificial operon encoding the required genes can be constructed. This operon is introduced using integrative plasmids and is coupled to counter-selection methods such as that allowed by the *Bacillus sacB*

gene (Link et al., J Bacteriol. 179:6228-6237 (1997)). In this way, markerless and scar less insertions at any location in the *E. coli* chromosome can be generated. Optimization involves altering gene order as well as ribosomal binding sites and promoters.

5 Throughout this application various publications have been referenced. The disclosures of these publications in their entireties are hereby incorporated by reference in this application in order to more fully describe the state of the art to which this invention pertains. Although the invention has been described with reference to the examples provided above, it should be understood that various modifications can be made without departing from the spirit of the invention.

What is claimed is:

1. A non-naturally occurring microorganism, comprising one or more exogenous proteins conferring to said microorganism a pathway to convert CO and H₂ to acetyl-coenzyme A (acetyl-CoA), wherein said microorganism lacks the ability to convert CO and H₂ to acetyl-CoA in the absence of said one or more exogenous proteins.
5
2. The non-naturally occurring microorganism of claim 1, wherein said one or more exogenous proteins is selected from cobalamide corrinoid/iron-sulfur protein, methyltransferase, carbon monoxide dehydrogenase, acetyl-CoA synthase, acetyl-CoA synthase disulfide reductase and hydrogenase.
- 10 3. The non-naturally occurring microorganism of claim 2, wherein cobalamide corrinoid/iron-sulfur protein, methyltransferase, carbon monoxide dehydrogenase, acetyl-CoA synthase, acetyl-CoA synthase disulfide reductase and hydrogenase are each expressed.
- 15 4. A non-naturally occurring microorganism, comprising one or more exogenous proteins conferring to said microorganism a pathway to convert a synthesis gas comprising CO and H₂ to acetyl-coenzyme A (acetyl-CoA), wherein said microorganism lacks the ability to convert CO and H₂ to acetyl-CoA in the absence of said one or more exogenous proteins.
5. The non-naturally occurring microorganism of claim 4, wherein said synthesis gas further comprises CO₂.
- 20 6. The non-naturally occurring microorganism of claim 5, wherein said one or more exogenous proteins is selected from cobalamide corrinoid/iron-sulfur protein, methyltransferase, carbon monoxide dehydrogenase, acetyl-CoA synthase, acetyl-CoA synthase disulfide reductase and hydrogenase.
- 25 7. The non-naturally occurring microorganism of claim 6, wherein cobalamide corrinoid/iron-sulfur protein, methyltransferase, carbon monoxide dehydrogenase, acetyl-CoA synthase, acetyl-CoA synthase disulfide reductase and hydrogenase are each expressed.

8. A non-naturally occurring microorganism, comprising one or more exogenous proteins conferring to said microorganism a pathway to convert CO₂ and H₂ to acetyl-coenzyme A (acetyl-CoA), wherein said microorganism lacks the ability to convert CO₂ and H₂ to acetyl-CoA in the absence of said one or more exogenous proteins.

5 9. The non-naturally occurring microorganism of claim 8, wherein said one or more exogenous proteins is selected from cobalamide corrinoid/iron-sulfur protein, methyltransferase, carbon monoxide dehydrogenase, acetyl-CoA synthase, acetyl-CoA synthase disulfide reductase and hydrogenase.

10 10. The non-naturally occurring microorganism of claim 9, wherein cobalamide corrinoid/iron-sulfur protein, methyltransferase, carbon monoxide dehydrogenase, acetyl-CoA synthase, acetyl-CoA synthase disulfide reductase and hydrogenase are each expressed.

15 11. A non-naturally occurring microorganism, comprising one or more exogenous proteins conferring to said microorganism a pathway to convert CO and H₂ to methyl-tetrahydrofolate (methyl-THF), wherein said microorganism lacks the ability to convert CO and H₂ to methyl-THF in the absence of said one or more exogenous proteins.

 12. The non-naturally occurring microorganism of claim 11, wherein said one or more exogenous proteins is selected from ferredoxin oxidoreductase, formate dehydrogenase, formyltetrahydrofolate synthetase, methenyltetrahydrofolate cyclodehydratase, methylenetetrahydrofolate dehydrogenase and methylenetetrahydrofolate reductase.

20 13. The non-naturally occurring microorganism of claim 12, wherein ferredoxin oxidoreductase, formate dehydrogenase, formyltetrahydrofolate synthetase, methenyltetrahydrofolate cyclodehydratase, methylenetetrahydrofolate dehydrogenase and methylenetetrahydrofolate reductase are each expressed.

25 14. A non-naturally occurring microorganism, comprising one or more exogenous proteins conferring to said microorganism a pathway to convert a synthesis gas comprising CO and H₂ to methyl-tetrahydrofolate (methyl-THF), wherein said microorganism lacks the ability to convert CO and H₂ to methyl-THF in the absence of said one or more exogenous proteins.

 15. The non-naturally occurring microorganism of claim 14, wherein said synthesis gas further comprises CO₂.

16. The non-naturally occurring microorganism of claim 15, wherein said one or more exogenous proteins is selected from ferredoxin oxidoreductase, formate dehydrogenase, formyltetrahydrofolate synthetase, methenyltetrahydrofolate cyclodehydratase, methylenetetrahydrofolate dehydrogenase and methylenetetrahydrofolate reductase.

5 17. The non-naturally occurring microorganism of claim 16, wherein ferredoxin oxidoreductase, formate dehydrogenase, formyltetrahydrofolate synthetase, methenyltetrahydrofolate cyclodehydratase, methylenetetrahydrofolate dehydrogenase and methylenetetrahydrofolate reductase are each expressed.

10 18. A non-naturally occurring microorganism, comprising one or more exogenous proteins conferring to said microorganism a pathway to convert CO₂ and H₂ to methyl-tetrahydrofolate (methyl-THF), wherein said microorganism lacks the ability to convert CO₂ and H₂ to methyl-THF in the absence of said one or more exogenous proteins.

15 19. The non-naturally occurring microorganism of claim 18, wherein said one or more exogenous proteins is selected from ferredoxin oxidoreductase, formate dehydrogenase, formyltetrahydrofolate synthetase, methenyltetrahydrofolate cyclodehydratase, methylenetetrahydrofolate dehydrogenase and methylenetetrahydrofolate reductase.

20 20. The non-naturally occurring microorganism of claim 19, wherein ferredoxin oxidoreductase, formate dehydrogenase, formyltetrahydrofolate synthetase, methenyltetrahydrofolate cyclodehydratase, methylenetetrahydrofolate dehydrogenase and methylenetetrahydrofolate reductase are each expressed.

25 21. A non-naturally occurring microorganism, comprising a genetic modification conferring to said microorganism an increased efficiency of producing acetyl-CoA from CO₂, CO and H₂, or a combination thereof, relative to said microorganism in the absence of said genetic modification, wherein said microorganism comprises a pathway to convert CO₂, CO and H₂, or a combination thereof, to acetyl-CoA.

22. The non-naturally occurring microorganism of claim 21, wherein said genetic modification comprises expression of one or more nucleic acid molecules encoding one or more exogenous proteins, whereby expression of said one or more exogenous proteins increases the efficiency of producing acetyl-CoA from CO₂, CO and H₂, or a combination thereof.

23. The non-naturally occurring microorganism of claim 22, wherein said one or more exogenous proteins is selected from cobalamide corrinoid/iron-sulfur protein, methyltransferase, carbon monoxide dehydrogenase, acetyl-coA synthase, acetyl-CoA synthase disulfide reductase and hydrogenase.

5 24. The non-naturally occurring microorganism of claim 23, wherein cobalamide corrinoid/iron-sulfur protein, methyltransferase, carbon monoxide dehydrogenase, acetyl-coA synthase, acetyl-CoA synthase disulfide reductase and hydrogenase are each expressed.

10 25. A non-naturally occurring microbial organism, comprising a microbial organism having an acetyl-coenzyme A (acetyl-CoA) pathway comprising at least one exogenous nucleic acid encoding an acetyl-CoA pathway enzyme or protein expressed in a sufficient amount to produce acetyl-CoA, said acetyl-CoA pathway comprising methanol-methyltransferase and acetyl-CoA synthase/carbon monoxide dehydrogenase.

15 26. The non-naturally occurring microbial organism of claim 25, wherein said acetyl-CoA pathway confers the ability to convert CO₂, CO or H₂, or a combination thereof, and methanol to acetyl-CoA.

 27. The non-naturally occurring microbial organism of claim 25, wherein the methanol-methyltransferase comprises an enzyme or protein selected from methanol methyltransferase, corrinoid protein and methyltetrahydrofolate:corrinoid protein methyltransferase.

20 28. The non-naturally occurring microbial organism of claim 25, wherein the acetyl-CoA synthase/carbon monoxide dehydrogenase comprises an enzyme or protein selected from methyltetrahydrofolate:corrinoid protein methyltransferase, corrinoid iron-sulfur protein, nickel-protein assembly protein, ferredoxin, acetyl-CoA synthase, carbon monoxide dehydrogenase and nickel-protein assembly protein.

29. The non-naturally occurring microbial organism of claim 25, wherein the methanol-methyltransferase comprises an enzyme or protein selected from methanol methyltransferase, corrinoid protein and methyltetrahydrofolate:corrinoid protein methyltransferase and the acetyl-CoA synthase/carbon monoxide dehydrogenase comprises an enzyme or protein selected from
5 methyltetrahydrofolate:corrinoid protein methyltransferase, corrinoid iron-sulfur protein, nickel-protein assembly protein, ferredoxin, acetyl-CoA synthase, carbon monoxide dehydrogenase and nickel-protein assembly protein.

30. The non-naturally occurring microbial organism of claim 25, wherein said microbial organism comprises two exogenous nucleic acids each encoding an acetyl-CoA pathway enzyme
10 or protein.

31. The non-naturally occurring microbial organism of claim 25, wherein said microbial organism comprises three exogenous nucleic acids each encoding an acetyl-CoA pathway enzyme or protein.

32. The non-naturally occurring microbial organism of claim 25, wherein said microbial
15 organism comprises four exogenous nucleic acids each encoding an acetyl-CoA pathway enzyme or protein.

33. The non-naturally occurring microbial organism of claim 25, wherein said microbial organism comprises five exogenous nucleic acids each encoding an acetyl-CoA pathway enzyme or protein.

20 34. The non-naturally occurring microbial organism of claim 25, wherein said microbial organism comprises six exogenous nucleic acids each encoding an acetyl-CoA pathway enzyme or protein.

25 35. The non-naturally occurring microbial organism of claim 25, wherein said microbial organism comprises seven exogenous nucleic acids each encoding an acetyl-CoA pathway enzyme or protein.

36. The non-naturally occurring microbial organism of claim 25, wherein said microbial organism comprises eight exogenous nucleic acids each encoding an acetyl-CoA pathway enzyme or protein.

37. The non-naturally occurring microbial organism of claim 25, wherein said microbial organism comprises nine exogenous nucleic acids each encoding an acetyl-CoA pathway enzyme or protein.

5 38. The non-naturally occurring microbial organism of claim 25, wherein said microbial organism comprises ten exogenous nucleic acids each encoding an acetyl-CoA pathway enzyme or protein.

39. The non-naturally occurring microbial organism of claim 38, wherein said ten exogenous nucleic acids encode a methanol-methyltransferase comprising methanol methyltransferase, corrinoid protein and methyltetrahydrofolate:corrinoid protein
10 methyltransferase and an acetyl-CoA synthase/carbon monoxide dehydrogenase comprising methyltetrahydrofolate:corrinoid protein methyltransferase, corrinoid iron-sulfur protein, nickel-protein assembly protein, ferredoxin, acetyl-CoA synthase, carbon monoxide dehydrogenase and nickel-protein assembly protein.

15 40. The non-naturally occurring microbial organism of claim 25, wherein said at least one exogenous nucleic acid is a heterologous nucleic acid.

41. The non-naturally occurring microbial organism of claim 25, wherein said non-naturally occurring microbial organism is in a substantially anaerobic culture medium.

42. The non-naturally occurring microbial organism of claim 25, wherein said non-naturally occurring microbial organism further comprises pyruvate ferredoxin oxidoreductase.

20 43. The non-naturally occurring microbial organism of claim 42, wherein pyruvate ferredoxin oxidoreductase is encoded by an exogenous nucleic acid.

44. The non-naturally occurring microbial organism of claim 25, wherein said non-naturally occurring microbial organism further comprises hydrogenase.

25 45. The non-naturally occurring microbial organism of claim 44, wherein said hydrogenase is encoded by an endogenous nucleic acid.

46. The non-naturally occurring microbial organism of claim 44, wherein said hydrogenase is encoded by an exogenous nucleic acid.

47. A method for producing acetyl-CoA, comprising culturing a non-naturally occurring microbial organism having an acetyl-CoA pathway, said pathway comprising at least one exogenous nucleic acid encoding an acetyl-CoA pathway enzyme or protein expressed in a sufficient amount to produce acetyl-CoA, under conditions and for a sufficient period of time to produce acetyl-CoA, said acetyl-CoA pathway comprising methanol-methyltransferase and acetyl-CoA synthase/carbon monoxide dehydrogenase.

48. The method of claim 47, wherein the methanol-methyltransferase comprises an enzyme or protein selected from methanol methyltransferase, corrinoid protein and methyltetrahydrofolate:corrinoid protein methyltransferase.

49. The method of claim 47, wherein the acetyl-CoA synthase/carbon monoxide dehydrogenase comprises an enzyme or protein selected from methyltetrahydrofolate:corrinoid protein methyltransferase, corrinoid iron-sulfur protein, nickel-protein assembly protein, ferredoxin, acetyl-CoA synthase, carbon monoxide dehydrogenase and nickel-protein assembly protein.

50. The method of claim 47, wherein the methanol-methyltransferase comprises an enzyme or protein selected from methanol methyltransferase, corrinoid protein and methyltetrahydrofolate:corrinoid protein methyltransferase and the acetyl-CoA synthase/carbon monoxide dehydrogenase comprises an enzyme or protein selected from methyltetrahydrofolate:corrinoid protein methyltransferase, corrinoid iron-sulfur protein, nickel-protein assembly protein, ferredoxin, acetyl-CoA synthase, carbon monoxide dehydrogenase and nickel-protein assembly protein.

51. The method of claim 47, wherein said non-naturally occurring microbial organism is in a substantially anaerobic culture medium.

52. The method of claim 51, wherein said non-naturally occurring microbial organism is cultured in the presence of CO₂, CO, or H₂, or a combination thereof, and methanol.

53. The method of claim 47, wherein said microbial organism comprises two exogenous nucleic acids each encoding an acetyl-CoA pathway enzyme or protein.

54. The method of claim 47, wherein said microbial organism comprises three exogenous nucleic acids each encoding an acetyl-CoA pathway enzyme or protein.

55. The method of claim 47, wherein said microbial organism comprises four exogenous nucleic acids each encoding an acetyl-CoA pathway enzyme or protein.

56. The method of claim 47, wherein said microbial organism comprises five exogenous nucleic acids each encoding an acetyl-CoA pathway enzyme or protein.

5 57. The method of claim 47, wherein said microbial organism comprises six exogenous nucleic acids each encoding an acetyl-CoA pathway enzyme or protein.

58. The method of claim 47, wherein said microbial organism comprises seven exogenous nucleic acids each encoding an acetyl-CoA pathway enzyme or protein.

10 59. The method of claim 47, wherein said microbial organism comprises eight exogenous nucleic acids each encoding an acetyl-CoA pathway enzyme or protein.

60. The method of claim 47, wherein said microbial organism comprises nine exogenous nucleic acids each encoding an acetyl-CoA pathway enzyme or protein.

61. The method of claim 47, wherein said microbial organism comprises ten exogenous nucleic acids each encoding an acetyl-CoA pathway enzyme or protein.

15 62. The method of claim 61, wherein said ten exogenous nucleic acids encode a methanol-methyltransferase comprising methanol methyltransferase, corrinoid protein and methyltetrahydrofolate:corrinoid protein methyltransferase and an acetyl-CoA synthase/carbon monoxide dehydrogenase comprising methyltetrahydrofolate:corrinoid protein methyltransferase, corrinoid iron-sulfur protein, nickel-protein assembly protein, ferredoxin,
20 acetyl-CoA synthase, carbon monoxide dehydrogenase and nickel-protein assembly protein.

63. The method of claim 47, wherein said at least one exogenous nucleic acid is a heterologous nucleic acid.

64. The method of claim 47, wherein said non-naturally occurring microbial organism further comprises pyruvate ferredoxin oxidoreductase.

25 65. The method of claim 64, wherein pyruvate ferredoxin oxidoreductase is encoded by an exogenous nucleic acid.

66. The method of claim 47, wherein said non-naturally occurring microbial organism further comprises hydrogenase.

67. The method of claim 66, wherein said hydrogenase is encoded by an endogenous nucleic acid.

5 68. The method of claim 66, wherein said hydrogenase is encoded by an exogenous nucleic acid.

69. The method of claim 51, wherein said non-naturally occurring microbial organism is cultured in the presence of nitrate.

70. A non-naturally occurring microbial organism, comprising a microbial organism
10 having a 4-hydroxybutyrate pathway comprising at least one exogenous nucleic acid encoding an
4-hydroxybutyrate pathway enzyme expressed in a sufficient amount to produce 4-
hydroxybutyrate, said 4-hydroxybutyrate pathway enzyme comprising an acetoacetyl-CoA
thiolase, a 3-hydroxybutyryl-CoA dehydrogenase, a crotonase, a crotonyl-CoA hydratase, a 4-
hydroxybutyryl-CoA transferase, a phosphotrans-4-hydroxybutyrylase, and a 4-hydroxybutyrate
15 kinase.

71. The organism of claim 70, wherein said Acetoacetyl-CoA thiolase is encoded by a gene selected from the group consisting of *atoB*, *thlA*, *thlB*, and *erg10*.

20 72. The organism of claim 70, wherein said 3-Hydroxybutyryl-CoA dehydrogenase is encoded by a gene selected from the group consisting of *hbd*, *msed_1423*, *msed_0399*, *msed_0389*, and *msed_1933*.

25 73. The organism of claim 70, wherein said Crotonase is encoded by a gene selected from the group consisting of *crt*, *paaA*, *paaB*, *phaA*, *phaB*, *maoC*, *paaF*, and *paaG*.

74. The organism of claim 70, wherein said crotonyl-CoA hydratase is encoded by a gene selected from the group consisting of *abfD*, *msed_1321*, and *msed_1220*.

30 75. The organism of claim 70, wherein said 4-hydroxybutyryl-CoA transferase is encoded by a gene selected from the group consisting of *cat2*, *abfT-2*, *abfT-1*, and *abfT*.

76. The organism of claim 70, wherein said phosphotrans-4-hydroxybutyrylase is encoded by a gene selected from the group consisting of *pta* and *ptb*.

5 77. The organism of claim 70, wherein said 4-hydroxybutyrate kinase is encoded by a gene selected from the group consisting of *ackA*, *buk1*, *buk2*, and *proB*.

78. The organism of claim 70, further comprising at least one enzyme or polypeptide selected from the group consisting of, a corrinoid protein, a methyltetrahydrofolate:corrinoid
10 protein methyltransferase, a corrinoid iron-sulfur protein, a nickel-protein assembly protein, a ferredoxin, an acetyl-CoA synthase, a carbon monoxide dehydrogenase, a pyruvate ferredoxin oxidoreductase, and a hydrogenase.

79. The organism of claim 78, wherein said corrinoid protein is encoded by a gene
15 selected from the group consisting of *mtaC*, *mtaC1*, *mtaC2*, and *mtaC3*.

80. The organism of claim 78, wherein said methyltetrahydrofolate:corrinoid protein methyltransferase is encoded by a gene selected from the group consisting of *mtaA*, and *mtaA1*,
20 *mtaA2*.

81. The organism of claim 78, wherein said methyltetrahydrofolate:corrinoid protein methyltransferase is encoded by the gene *acsE*.

82. The organism of claim 78, wherein said corrinoid iron-sulfur protein is encoded
25 by the gene *acsD*.

83. The organism of claim 78, wherein said nickel-protein assembly protein is encoded by at least one gene selected from the group consisting of *acsF* and *cooC*.

30 84. The organism of claim 78, wherein said ferredoxin is encoded by the gene *orf7*.

85. The organism of claim 78, wherein said acetyl-CoA synthase is encoded by at least one gene selected from the group consisting of *acsB* and *acsC*.

86. The organism of claim 78, wherein said carbon monoxide dehydrogenase is encoded by the gene *acsA*.

5 87. The organism of claim 78, wherein said pyruvate ferredoxin oxidoreductase is encoded by a gene selected from the group consisting of *por* and *ydbK*.

88. The organism of claim 78, wherein said hydrogenase is encoded by at least one gene selected from the group consisting of *hypA*, *hypB*, *hypC*, *hypD*, *hypE*, *hypF*, *moth_2175*,
10 *moth_2176*, *moth_2177*, *moth_2178*, *moth_2179*, *moth_2180*, *moth_2181*, *hycA*, *hycB*, *hycC*,
hycD, *hycE*, *hycF*, *hycG*, *hycH*, *hycI*, *hyfA*, *hyfB*, *hyfC*, *hyfD*, *hyfE*, *hyfF*, *hyfG*, *hyfH*, *hyfI*, *hyfJ*,
hyfR, *moth_2182*, *moth_2183*, *moth_2184*, *moth_2185*, *moth_2186*, *moth_2187*, *moth_2188*,
moth_2189, *moth_2190*, *moth_2191*, *moth_2192*, *moth_0439*, *moth_0440*, *moth_0441*,
moth_0442, *moth_0809*, *moth_0810*, *moth_0811*, *moth_0812*, *moth_0813*, *moth_0814*,
15 *moth_0815*, *moth_0816*, *moth_1193*, *moth_1194*, *moth_1195*, *moth_1196*, *moth_1717*,
moth_1718, *moth_1719*, *moth_1883*, *moth_1884*, *moth_1885*, *moth_1886*, *moth_1887*,
moth_1888, *moth_1452*, *moth_1453*, and *moth_1454*.

89. The organism of claim 78, further comprising the polypeptide AcsEps encoded by
20 the gene *acsEps*.

90. The organism of claim 78, further comprising at least one enzyme or polypeptide encoded by a gene selected from the group consisting of *codh*, *codh-I*, *cooF*, *hypA*, *cooH*, *cooU*,
cooX, *cooL*, *cooK*, *cooM*, *cooT*, *cooJ*, and *codh-II*.

25

91. The organism of claim 78, further comprising a methanol methyltransferase.

92. The organism of claim 91, wherein said methanol methyltransferase is encoded by a gene selected from the group consisting of *mtaB*, *mtaB1*, *mtaB2*, and *mtaB3*.

30

93. The organism of claim 91, wherein said organism utilizes a feedstock selected from the group consisting of: 1) methanol and CO, 2) methanol, CO₂, and H₂, 3) methanol, CO, CO₂, and H₂, 4) methanol and synthesis gas comprising CO and H₂, and 5) methanol and synthesis gas comprising CO, CO₂, and H₂.

5

94. The organism of claim 78, further comprising a formate dehydrogenase, a formyltetrahydrofolate synthetase, a methenyltetrahydrofolate cyclohydrolase, a methylenetetrahydrofolate dehydrogenase, and a methylenetetrahydrofolate reductase.

10

95. The organism of claim 94, wherein said formate dehydrogenase is encoded by a gene selected from the group consisting of *moth_2312*, *moth_2313*, *moth_2314*, *sfum_2703*, *sfum_2704*, *sfum_2705*, *sfum_2706*, *chy_0731*, *chy_0732*, and *chy_0733*.

15

96. The organism of claim 94, wherein said formyltetrahydrofolate synthetase is encoded by a gene selected from the group consisting of *moth_0109*, *chy_2385*, and *fhs*.

97. The organism of claim 94, wherein said methenyltetrahydrofolate cyclohydrolase is encoded by a gene selected from the group consisting of *moth_1516*, *fold*, and *chy_1878*.

20

98. The organism of claim 94, wherein said methylenetetrahydrofolate dehydrogenase is encoded by a gene selected from the group consisting of *moth_1516*, *fold*, and *chy_1878*.

99. The organism of claim 94, wherein said methylenetetrahydrofolate reductase is encoded by a gene selected from the group consisting of *moth_1191*, *metF*, and *chy_1233*.

25

100. The organism of claim 94, wherein said organism utilizes a feedstock selected from the group consisting of: 1) CO, 2) CO₂ and H₂, 3) CO and CO₂, 4) synthesis gas comprising CO and H₂, and 5) synthesis gas comprising CO, CO₂, and H₂.

101. A non-naturally occurring microbial organism comprising a microbial organism having a 1,4-butanediol pathway comprising at least one exogenous nucleic acid encoding a 1,4-butanediol pathway enzyme expressed in a sufficient amount to produce 1,4-butanediol, said 1,4-butanediol pathway enzyme comprising an acetoacetyl-CoA thiolase, a 3-Hydroxybutyryl-CoA dehydrogenase, a crotonase, a crotonyl-CoA hydratase, a 4-hydroxybutyryl-CoA reductase (alcohol forming), a 4-hydroxybutyryl-CoA reductase (aldehyde forming), and a 1,4-butanediol dehydrogenase; said organism further comprising an acetyl-CoA pathway comprising at least one exogenous nucleic acid encoding an acetyl-CoA pathway enzyme expressed in a sufficient amount to produce acetyl-CoA, said acetyl-CoA pathway enzyme comprising a corrinoid protein, a methyltetrahydrofolate:corrinoid protein methyltransferase, a corrinoid iron-sulfur protein, a nickel-protein assembly protein, a ferredoxin, an acetyl-CoA synthase, a carbon monoxide dehydrogenase, a pyruvate ferredoxin oxidoreductase, and a hydrogenase.

102. The organism of claim 101, wherein said acetoacetyl-CoA thiolase is encoded by a gene selected from the group consisting of *atoB*, *thlA*, *thlB*, and *erg10*.

103. The organism of claim 101, wherein said 3-Hydroxybutyryl-CoA dehydrogenase is encoded by a gene selected from the group consisting of *hbd*, *msed_1423*, *msed_0399*, *msed_0389*, and *msed_1933*.

104. The organism of claim 101, wherein said crotonase is encoded by a gene selected from the group consisting of *crt*, *paaA*, *paaB*, *phaA*, *phaB*, *maoC*, *paaF*, and *paaG*.

105. The organism of claim 101, wherein said crotonyl-CoA hydratase is encoded by a gene selected from the group consisting of *abfD*, *msed_1321*, and *msed_1220*.

106. The organism of claim 101, wherein said 4-hydroxybutyryl-CoA reductase (alcohol forming) is encoded by a gene selected from the group consisting of *adhE*, *adhE2*, *mcr*, *rcas_2929*, *nap1_02720*, and *mgp2080_00535*.

107. The organism of claim 101, wherein said 4-hydroxybutyryl-CoA reductase (aldehyde forming) is encoded by a gene selected from the group consisting of *acr1*, *sucD*, *bphG*, *msed_0709*, *mcr*, *asd-2*, and *saci_2370*.

108. The organism of claim 101, wherein said 1,4-butanediol dehydrogenase is encoded by a gene selected from the group consisting of *alrA*, *adh2*, *yqhD*, *bdh I*, *bdh II*, and *4hbd*.

5

109. The organism of claim 101, wherein said corrinoid protein is encoded by a gene selected from the group consisting of *mtaC*, *mtaC1*, *mtaC2*, and *mtaC3*.

110. The organism of claim 101, wherein said methyltetrahydrofolate:corrinoid protein methyltransferase is encoded by a gene selected from the group consisting of *mtaA*, and *mtaA1*, *mtaA2*.

10

111. The organism of claim 101, wherein said methyltetrahydrofolate:corrinoid protein methyltransferase is encoded by the gene *acsE*.

15

112. The organism of claim 101, wherein said corrinoid iron-sulfur protein is encoded by the gene *acsD*.

113. The organism of claim 101, wherein said nickel-protein assembly protein is encoded by at least one gene selected from the group consisting of *acsF* and *cooC*.

20

114. The organism of claim 101, wherein said ferredoxin is encoded by the gene *orf7*.

115. The organism of claim 101, wherein said acetyl-CoA synthase is encoded by at least one gene selected from the group consisting of *acsB* and *acsC*.

25

116. The organism of claim 101, wherein said carbon monoxide dehydrogenase is encoded by the gene *acsA*.

117. The organism of claim 101, wherein said pyruvate ferredoxin oxidoreductase is encoded by a gene selected from the group consisting of *por* and *ydbK*.

30

118. The organism of claim 101, wherein said hydrogenase is encoded by at least one gene selected from the group consisting of *hypA*, *hypB*, *hypC*, *hypD*, *hypE*, *hypF*, *moth_2175*, *moth_2176*, *moth_2177*, *moth_2178*, *moth_2179*, *moth_2180*, *moth_2181*, *hycA*, *hycB*, *hycC*, *hycD*, *hycE*, *hycF*, *hycG*, *hycH*, *hycI*, *hyfA*, *hyfB*, *hyfC*, *hyfD*, *hyfE*, *hyfF*, *hyfG*, *hyfH*, *hyfI*, *hyfJ*,
5 *hyfR*, *moth_2182*, *moth_2183*, *moth_2184*, *moth_2185*, *moth_2186*, *moth_2187*, *moth_2188*,
moth_2189, *moth_2190*, *moth_2191*, *moth_2192*, *moth_0439*, *moth_0440*, *moth_0441*,
moth_0442, *moth_0809*, *moth_0810*, *moth_0811*, *moth_0812*, *moth_0813*, *moth_0814*,
moth_0815, *moth_0816*, *moth_1193*, *moth_1194*, *moth_1195*, *moth_1196*, *moth_1717*,
moth_1718, *moth_1719*, *moth_1883*, *moth_1884*, *moth_1885*, *moth_1886*, *moth_1887*,
10 *moth_1888*, *moth_1452*, *moth_1453*, and *moth_1454*.

119. The organism of claim 101, further comprising the polypeptide AcsEps encoded by the gene *acsEps*.

120. The organism of claim 101, further comprising at least one enzyme or polypeptide encoded by a gene selected from the group consisting of *codh*, *codh-I*, *cooF*, *hypA*, *cooH*, *cooU*, *cooX*, *cooL*, *cooK*, *cooM*, *cooT*, *cooJ*, and *codh-II*.

121. The organism of claim 101, further comprising a methanol methyltransferase.
20

122. The organism of claim 121, wherein said methanol methyltransferase is encoded by a gene selected from the group consisting of *mtaB*, *mtaB1*, *mtaB2*, and *mtaB3*.

123. The organism of claim 121, wherein said organism utilizes a feedstock selected
25 from the group consisting of: 1) methanol and CO, 2) methanol, CO₂, and H₂, 3) methanol, CO, CO₂, and H₂, 4) methanol and synthesis gas comprising CO and H₂, and 5) methanol and synthesis gas comprising CO, CO₂, and H₂.

124. A non-naturally occurring microbial organism comprising a microbial organism having a 1,4-butanediol pathway comprising at least one exogenous nucleic acid encoding a 1,4-butanediol pathway enzyme expressed in a sufficient amount to produce 1,4-butanediol, said 1,4-butanediol pathway enzyme comprising an acetoacetyl-CoA thiolase, a 3-Hydroxybutyryl-CoA dehydrogenase, a crotonase, a crotonyl-CoA hydratase, a 4-hydroxybutyryl-CoA reductase (alcohol forming), a 4-hydroxybutyryl-CoA reductase (aldehyde forming), and a 1,4-butanediol dehydrogenase; said organism further comprising an acetyl-CoA pathway comprising at least one exogenous nucleic acid encoding an acetyl-CoA pathway enzyme expressed in a sufficient amount to produce acetyl-CoA, said acetyl-CoA pathway enzyme comprising an acetyl-CoA synthase, a formate dehydrogenase, a formyltetrahydrofolate synthetase, a methenyltetrahydrofolate cyclohydrolase, a methylenetetrahydrofolate dehydrogenase, and a methylenetetrahydrofolate reductase.

125. The organism of claim 124, wherein said formate dehydrogenase is encoded by a gene selected from the group consisting of *moth_2312*, *moth_2313*, *moth_2314*, *sfum_2703*, *sfum_2704*, *sfum_2705*, *sfum_2706*, *chy_0731*, *chy_0732*, and *chy_0733*.

126. The organism of claim 124, wherein said formyltetrahydrofolate synthetase is encoded by a gene selected from the group consisting of *moth_0109*, *chy_2385*, and *fhs*.

127. The organism of claim 124, wherein said methenyltetrahydrofolate cyclohydrolase is encoded by a gene selected from the group consisting of *moth_1516*, *fold*, and *chy_1878*.

128. The organism of claim 124, wherein said methylenetetrahydrofolate dehydrogenase is encoded by a gene selected from the group consisting of *moth_1516*, *fold*, and *chy_1878*.

129. The organism of claim 124, wherein said methylenetetrahydrofolate reductase is encoded by a gene selected from the group consisting of *moth_1191*, *metF*, and *chy_1233*.

130. The organism of claim 124, wherein said organism utilizes a feedstock selected from the group consisting of: 1) CO, 2) CO₂ and H₂, 3) CO and CO₂, 4) synthesis gas comprising CO and H₂, and 5) synthesis gas comprising CO, CO₂, and H₂.

5 131. A method for producing 4-hydroxybutyrate, comprising culturing a non-naturally occurring microbial organism having an 4-hydroxybutyrate pathway, said pathway comprising at least one exogenous nucleic acid encoding an 4-hydroxybutyrate pathway enzyme expressed in a sufficient amount to produce 4-hydroxybutyrate under conditions and for a sufficient period of time to produce 4-hydroxybutyrate, said 4-hydroxybutyrate pathway comprising an acetoacetyl-
10 CoA thiolase, a 3-hydroxybutyryl-CoA dehydrogenase, a crotonase, a crotonyl-CoA hydratase, a 4-hydroxybutyryl-CoA transferase, a phosphotrans-4-hydroxybutyrylase, and a 4-hydroxybutyrate kinase.

132. The method of claim 131, wherein said Acetoacetyl-CoA thiolase is encoded by a
15 gene selected from the group consisting of *atoB*, *thlA*, *thlB*, and *erg10*.

133. The method of claim 131, wherein said 3-Hydroxybutyryl-CoA dehydrogenase is encoded by a gene selected from the group consisting of *hbd*, *msed_1423*, *msed_0399*,
msed_0389, and *msed_1933*.

20

134. The method of claim 131, wherein said Crotonase is encoded by a gene selected from the group consisting of *crt*, *paaA*, *paaB*, *phaA*, *phaB*, *maoC*, *paaF*, and *paaG*.

135. The method of claim 131, wherein said Crotonyl-CoA hydratase is encoded by a
25 gene selected from the group consisting of *abfD*, *msed_1321*, and *msed_1220*.

136. The method of claim 131, wherein said 4-Hydroxybutyryl-CoA transferase is encoded by a gene selected from the group consisting of *cat2*, *abfT-2*, *abfT-1*, and *abfT*.

30 137. The method of claim 131, wherein said Phosphotrans-4-hydroxybutyrylase is encoded by a gene selected from the group consisting of *pta* and *ptb*.

138. The method of claim 131, wherein said 4-Hydroxybutyrate kinase is encoded by a gene selected from the group consisting of *ackA*, *buk1*, *buk2*, and *proB*.

139. The method of claim 131, wherein said organism further comprises at least one enzyme or polypeptide selected from the group consisting of, a corrinoid protein, a methyltetrahydrofolate:corrinoid protein methyltransferase, a corrinoid iron-sulfur protein, a nickel-protein assembly protein, a ferredoxin, an acetyl-CoA synthase, a carbon monoxide dehydrogenase, a pyruvate ferredoxin oxidoreductase, and a hydrogenase.

140. The method of claim 131, wherein said corrinoid protein is encoded by a gene selected from the group consisting of *mtaC*, *mtaC1*, *mtaC2*, and *mtaC3*.

141. The method of claim 139, wherein said methyltetrahydrofolate:corrinoid protein methyltransferase is encoded by a gene selected from the group consisting of *mtaA*, and *mtaA1*, *mtaA2*.

142. The method of claim 139, wherein said methyltetrahydrofolate:corrinoid protein methyltransferase is encoded by the gene *acsE*.

143. The method of claim 139, wherein said corrinoid iron-sulfur protein is encoded by the gene *acsD*.

144. The method of claim 139, wherein said nickel-protein assembly protein is encoded by at least one gene selected from the group consisting of *acsF* and *cooC*.

145. The method of claim 139, wherein said ferredoxin is encoded by the gene *orf7*.

146. The method of claim 139, wherein said acetyl-CoA synthase is encoded by at least one gene selected from the group consisting of *acsB* and *acsC*.

147. The method of claim 139, wherein said carbon monoxide dehydrogenase is encoded by the gene *acsA*.

148. The method of claim 139, wherein said pyruvate ferredoxin oxidoreductase is encoded by a gene selected from the group consisting of *por* and *ydbK*.

149. The method of claim 139, wherein said hydrogenase is encoded by at least one
5 gene selected from the group consisting of *hypA*, *hypB*, *hypC*, *hypD*, *hypE*, *hypF*, *moth_2175*,
moth_2176, *moth_2177*, *moth_2178*, *moth_2179*, *moth_2180*, *moth_2181*, *hycA*, *hycB*, *hycC*,
hycD, *hycE*, *hycF*, *hycG*, *hycH*, *hycI*, *hyfA*, *hyfB*, *hyfC*, *hyfD*, *hyfE*, *hyfF*, *hyfG*, *hyfH*, *hyfI*, *hyfJ*,
hyfR, *moth_2182*, *moth_2183*, *moth_2184*, *moth_2185*, *moth_2186*, *moth_2187*, *moth_2188*,
10 *moth_2189*, *moth_2190*, *moth_2191*, *moth_2192*, *moth_0439*, *moth_0440*, *moth_0441*,
moth_0442, *moth_0809*, *moth_0810*, *moth_0811*, *moth_0812*, *moth_0813*, *moth_0814*,
moth_0815, *moth_0816*, *moth_1193*, *moth_1194*, *moth_1195*, *moth_1196*, *moth_1717*,
moth_1718, *moth_1719*, *moth_1883*, *moth_1884*, *moth_1885*, *moth_1886*, *moth_1887*,
moth_1888, *moth_1452*, *moth_1453*, and *moth_1454*.

150. The method of claim 139, further comprising the polypeptide AcsEps encoded by
15 the gene *acsEps*.

151. The method of claim 139, further comprising at least one enzyme or polypeptide
encoded by a gene selected from the group consisting of *codh*, *codh-I*, *cooF*, *hypA*, *cooH*, *cooU*,
20 *cooX*, *cooL*, *cooK*, *cooM*, *cooT*, *cooJ*, and *codh-II*.

152. The method of claim 139, further comprising a methanol methyltransferase.

153. The method of claim 152, wherein said methanol methyltransferase is encoded by
25 a gene selected from the group consisting of *mtaB*, *mtaB1*, *mtaB2*, and *mtaB3*.

154. The method of claim 152, wherein said organism utilizes a feedstock selected
from the group consisting of: 1) methanol and CO, 2) methanol, CO₂, and H₂, 3) methanol, CO,
CO₂, and H₂, 4) methanol and synthesis gas comprising CO and H₂, and 5) methanol and
30 synthesis gas comprising CO, CO₂, and H₂.

155. The method of claim 139, wherein said organism further comprises a formate dehydrogenase, a formyltetrahydrofolate synthetase, a methenyltetrahydrofolate cyclohydrolase, a methylenetetrahydrofolate dehydrogenase, and a methylenetetrahydrofolate reductase.

5 156. The method of claim 155, wherein said formate dehydrogenase is encoded by a gene selected from the group consisting of *moth_2312*, *moth_2313*, *moth_2314*, *sfum_2703*, *sfum_2704*, *sfum_2705*, *sfum_2706*, *chy_0731*, *chy_0732*, and *chy_0733*.

10 157. The method of claim 155, wherein said formyltetrahydrofolate synthetase is encoded by a gene selected from the group consisting of *moth_0109*, *chy_2385*, and *fhs*.

158. The method of claim 155, wherein said methenyltetrahydrofolate cyclohydrolase is encoded by a gene selected from the group consisting of *moth_1516*, *fold*, and *chy_1878*.

15 159. The method of claim 155, wherein said methylenetetrahydrofolate dehydrogenase is encoded by a gene selected from the group consisting of *moth_1516*, *fold*, and *chy_1878*.

160. The method of claim 155, wherein said methylenetetrahydrofolate reductase is encoded by a gene selected from the group consisting of *moth_1191*, *metF*, and *chy_1233*.

20

161. The method of claim 155, wherein said organism utilizes a feedstock selected from the group consisting of: 1) CO, 2) CO₂ and H₂, 3) CO and CO₂, 4) synthesis gas comprising CO and H₂, and 5) synthesis gas comprising CO, CO₂, and H₂.

25 162. A method for producing 1,4-butanediol, comprising culturing a non-naturally occurring microbial organism having an 1,4-butanediol pathway, said pathway comprising at least one exogenous nucleic acid encoding an 1,4-butanediol pathway enzyme expressed in a sufficient amount to produce 1,4-butanediol under conditions and for a sufficient period of time to produce 1,4-butanediol, said 1,4-butanediol pathway comprising an acetoacetyl-CoA thiolase, 30 a 3-Hydroxybutyryl-CoA dehydrogenase, a crotonase, a crotonyl-CoA hydratase, a 4-hydroxybutyryl-CoA reductase (alcohol forming), a 4-hydroxybutyryl-CoA reductase (aldehyde forming), a 1,4-butanediol dehydrogenase; said organism further comprising an acetyl-CoA pathway comprising at least one exogenous nucleic acid encoding an acetyl-CoA pathway

enzyme expressed in a sufficient amount to produce acetyl-CoA, said acetyl-CoA pathway enzyme comprising a corrinoid protein, a methyltetrahydrofolate:corrinoid protein methyltransferase, a corrinoid iron-sulfur protein, a nickel-protein assembly protein, a ferredoxin, an acetyl-CoA synthase, a carbon monoxide dehydrogenase, a pyruvate ferredoxin oxidoreductase, and a hydrogenase.

163. The method of claim 162, wherein said Acetoacetyl-CoA thiolase is encoded by a gene selected from the group consisting of *atoB*, *thlA*, *thlB*, and *erg10*.

10 164. The method of claim 162, wherein said 3-Hydroxybutyryl-CoA dehydrogenase is encoded by a gene selected from the group consisting of *hbd*, *msed_1423*, *msed_0399*, *msed_0389*, and *msed_1933*.

165. The method of claim 162, wherein said Crotonase is encoded by a gene selected from the group consisting of *crt*, *paaA*, *paaB*, *phaA*, *phaB*, *maoC*, *paaF*, and *paaG*.

166. The method of claim 162, wherein said Crotonyl-CoA hydratase is encoded by a gene selected from the group consisting of *abfD*, *msed_1321*, and *msed_1220*.

20 167. The method of claim 162, wherein said 4-hydroxybutyryl-CoA reductase (alcohol forming) is encoded by a gene selected from the group consisting of *adhE*, *adhE2*, *mcr*, *rcas_2929*, *nap1_02720*, and *mgp2080_00535*.

25 168. The method of claim 162, wherein said 4-hydroxybutyryl-CoA reductase (aldehyde forming) is encoded by a gene selected from the group consisting of *acr1*, *sucD*, *bphG*, *msed_0709*, *mcr*, *asd-2*, and *saci_2370*.

169. The method of claim 162, wherein said 1,4-butanediol dehydrogenase is encoded by a gene selected from the group consisting of *alrA*, *adh2*, *yqhD*, *bdh I*, *bdh II*, and *4hbd*.

30 170. The method of claim 162, wherein said corrinoid protein is encoded by a gene selected from the group consisting of *mtaC*, *mtaC1*, *mtaC2*, and *mtaC3*.

171. The method of claim 162, wherein said methyltetrahydrofolate:corrinoid protein methyltransferase is encoded by a gene selected from the group consisting of *mtaA*, and *mtaA1*, *mtaA2*.

5 172. The method of claim 162, wherein said methyltetrahydrofolate:corrinoid protein methyltransferase is encoded by the gene *acsE*.

173. The method of claim 162, wherein said corrinoid iron-sulfur protein is encoded by the gene *acsD*.

10

174. The method of claim 162, wherein said nickel-protein assembly protein is encoded by at least one gene selected from the group consisting of *acsF* and *cooC*.

175. The method of claim 162, wherein said ferredoxin is encoded by the gene *orf7*.

15

176. The method of claim 162, wherein said acetyl-CoA synthase is encoded by at least one gene selected from the group consisting of *acsB* and *acsC*.

177. The method of claim 162, wherein said carbon monoxide dehydrogenase is encoded by the gene *acsA*.

20

178. The method of claim 162, wherein said pyruvate ferredoxin oxidoreductase is encoded by a gene selected from the group consisting of *por* and *ydbK*.

25 179. The method of claim 162, wherein said hydrogenase is encoded by at least one gene selected from the group consisting of *hypA*, *hypB*, *hypC*, *hypD*, *hypE*, *hypF*, *moth_2175*, *moth_2176*, *moth_2177*, *moth_2178*, *moth_2179*, *moth_2180*, *moth_2181*, *hycA*, *hycB*, *hycC*, *hycD*, *hycE*, *hycF*, *hycG*, *hycH*, *hycI*, *hyfA*, *hyfB*, *hyfC*, *hyfD*, *hyfE*, *hyfF*, *hyfG*, *hyfH*, *hyfI*, *hyfJ*, *hyfR*, *moth_2182*, *moth_2183*, *moth_2184*, *moth_2185*, *moth_2186*, *moth_2187*, *moth_2188*,
30 *moth_2189*, *moth_2190*, *moth_2191*, *moth_2192*, *moth_0439*, *moth_0440*, *moth_0441*, *moth_0442*, *moth_0809*, *moth_0810*, *moth_0811*, *moth_0812*, *moth_0813*, *moth_0814*, *moth_0815*, *moth_0816*, *moth_1193*, *moth_1194*, *moth_1195*, *moth_1196*, *moth_1717*,

moth_1718, moth_1719, moth_1883, moth_1884, moth_1885, moth_1886, moth_1887, moth_1888, moth_1452, moth_1453, and moth_1454.

180. The method of claim 162, wherein said organism further comprises the polypeptide
5 AcsEps encoded by the gene *acsEps*.

181. The method of claim 162, further comprising at least one enzyme or polypeptide
encoded by a gene selected from the group consisting of *codh, codh-I, cooF, hypA, cooH, cooU, cooX, cooL, cooK, cooM, cooT, cooJ, and codh-II.*

10

182. The method of claim 162, further comprising a methanol methyltransferase.

183. The method of claim 162, wherein said methanol methyltransferase is encoded by
a gene selected from the group consisting of *mtaB, mtaB1, mtaB2, and mtaB3.*

15

184. The method of claim 162, wherein said organism utilizes a feedstock selected
from the group consisting of: 1) methanol and CO, 2) methanol, CO₂, and H₂, 3) methanol, CO,
CO₂, and H₂, 4) methanol and synthesis gas comprising CO and H₂, and 5) methanol and
synthesis gas comprising CO, CO₂, and H₂.

20

185. A method for producing 1,4-butanediol, comprising culturing a non-naturally
occurring microbial organism having an 1,4-butanediol pathway, said pathway comprising at
least one exogenous nucleic acid encoding an 1,4-butanediol pathway enzyme expressed in a
sufficient amount to produce 1,4-butanediol under conditions and for a sufficient period of time
25 to produce 1,4-butanediol, said 1,4-butanediol pathway comprising an acetoacetyl-CoA thiolase,
a 3-hydroxybutyryl-CoA dehydrogenase, a crotonase, a crotonyl-CoA hydratase, a 4-
hydroxybutyryl-CoA reductase (alcohol forming), a 4-hydroxybutyryl-CoA reductase (aldehyde
forming), a 1,4-butanediol dehydrogenase; said organism further comprising an acetyl-CoA
pathway comprising at least one exogenous nucleic acid encoding an acetyl-CoA pathway
30 enzyme expressed in a sufficient amount to produce acetyl-CoA, said acetyl-CoA pathway
enzyme comprising an acetyl-CoA synthase, a formate dehydrogenase, a formyltetrahydrofolate
synthetase, a methenyltetrahydrofolate cyclohydrolase, a methylenetetrahydrofolate
dehydrogenase, and a methylenetetrahydrofolate reductase.

186. The method of claim 185, wherein said formate dehydrogenase is encoded by a gene selected from the group consisting of *moth_2312*, *moth_2313*, *moth_2314*, *sfum_2703*, *sfum_2704*, *sfum_2705*, *sfum_2706*, *chy_0731*, *chy_0732*, and *chy_0733*.

5

187. The method of claim 185, wherein said formyltetrahydrofolate synthetase is encoded by a gene selected from the group consisting of *moth_0109*, *chy_2385*, and *fhs*.

188. The method of claim 185, wherein said methenyltetrahydrofolate cyclohydrolase
10 is encoded by a gene selected from the group consisting of *moth_1516*, *fold*, and *chy_1878*.

189. The method of claim 185, wherein said methylenetetrahydrofolate dehydrogenase is encoded by a gene selected from the group consisting of *moth_1516*, *fold*, and *chy_1878*.

190. The method of claim 185, wherein said methylenetetrahydrofolate reductase is
15 encoded by a gene selected from the group consisting of *moth_1191*, *metF*, and *chy_1233*.

191. The method of claim 185, wherein said organism utilizes a feedstock selected
from the group consisting of: 1) CO, 2) CO₂ and H₂, 3) CO and CO₂, 4) synthesis gas comprising
20 CO and H₂, and 5) synthesis gas comprising CO, CO₂, and H₂.

Syngas to Chemicals - Pathways 1

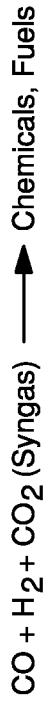

2 Branches of Pathway

- 1.) Methyl Branch: Syngas \longrightarrow Methyl-tetrahydrofolate (Me-THF)
- 2.) Carbonyl Branch: Me-THF + Syngas \longrightarrow Acetyl-CoA

Methyl Branch- CO and CO₂ reduction

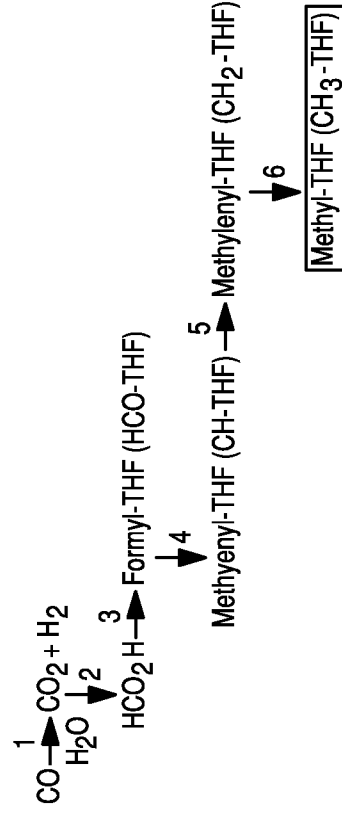

Methyl Branch

Enzymes Implicated

- 1. Ferredoxin oxidoreductase
- 2. Formate dehydrogenase
- 3. Formyltetrahydrofolate synthetase
- 4. Methylenetetrahydrofolate cyclodehydratase
- 5. Methylenetetrahydrofolate dehydrogenase
- 6. Methylenetetrahydrofolate reductase

FIG. 1

Syngas to Chemicals - Pathways 2

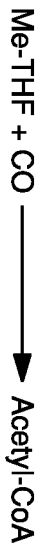

Carbonyl Branch - Acetyl-CoA synthesis

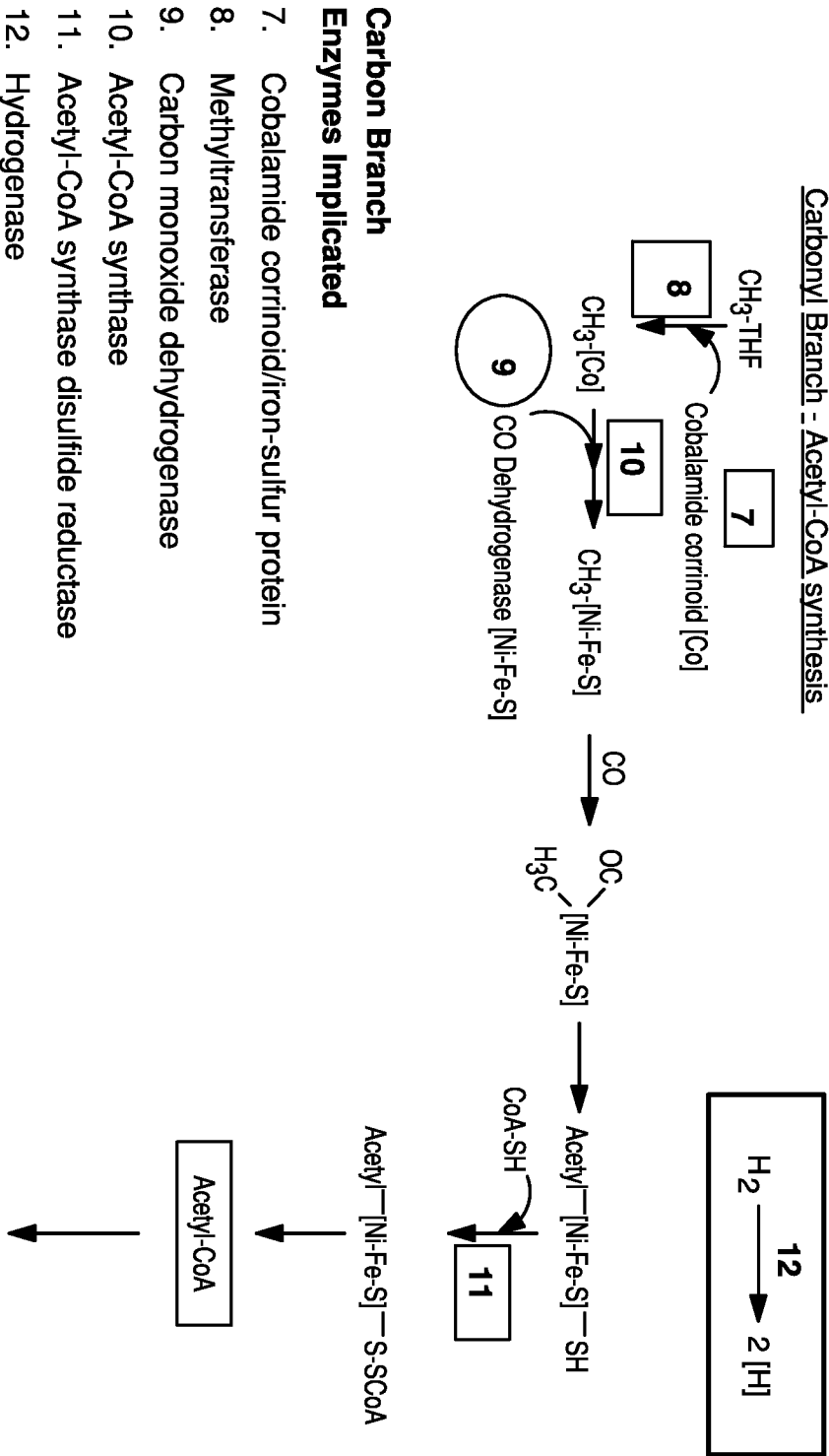

2/15

Carbon Branch
Enzymes Implicated

7. Cobalamide corrinoid/iron-sulfur protein
8. Methyltransferase
9. Carbon monoxide dehydrogenase
10. Acetyl-CoA synthase
11. Acetyl-CoA synthase disulfide reductase
12. Hydrogenase

FIG. 2

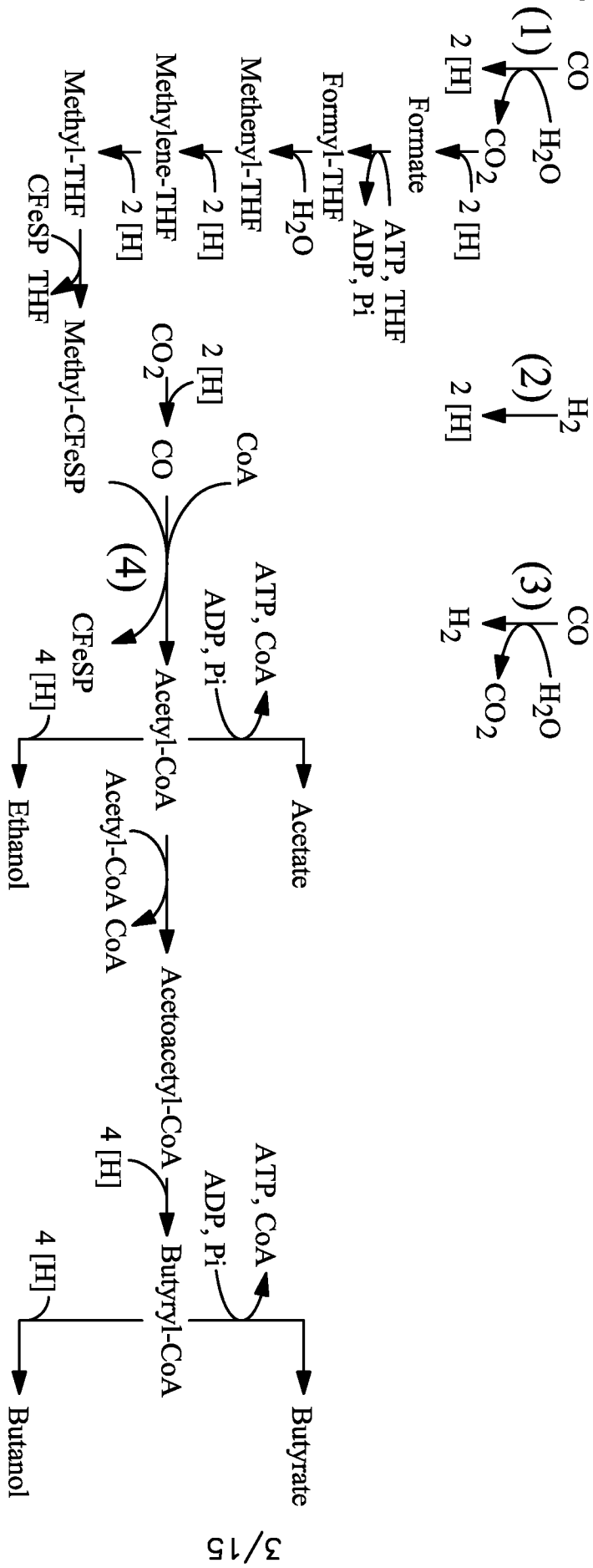

3/15

FIG. 3

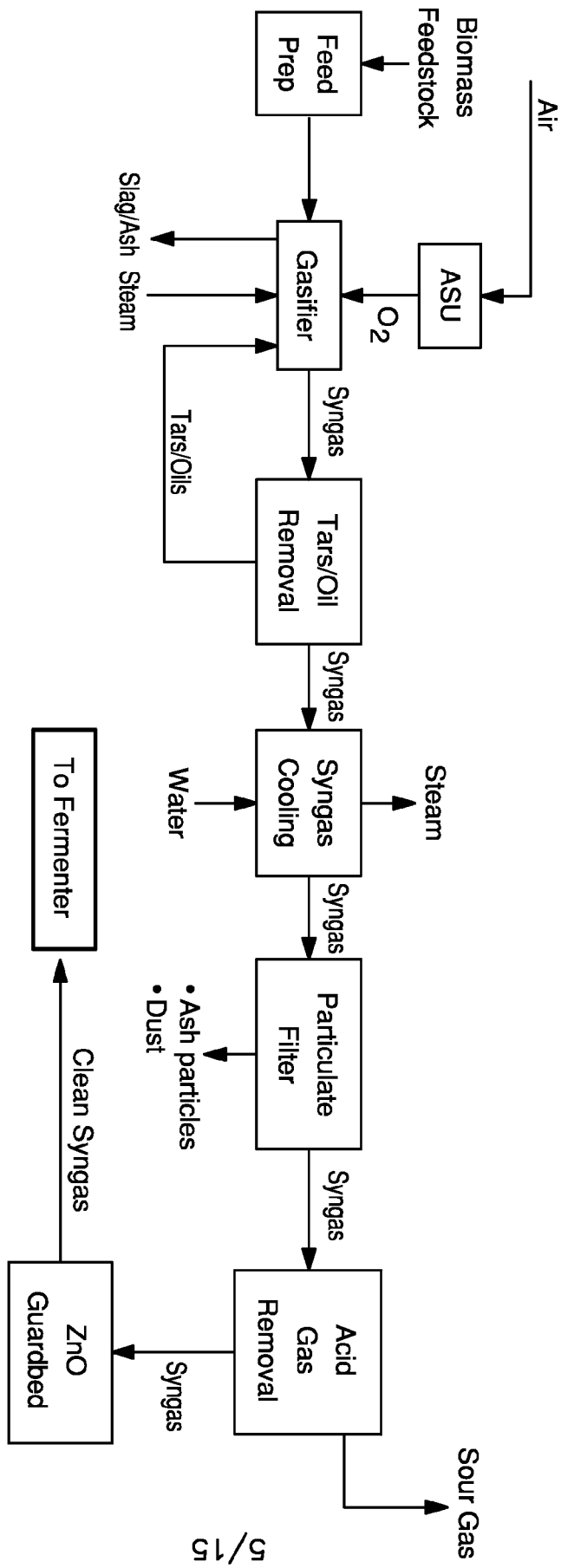

5/15

FIG. 4B

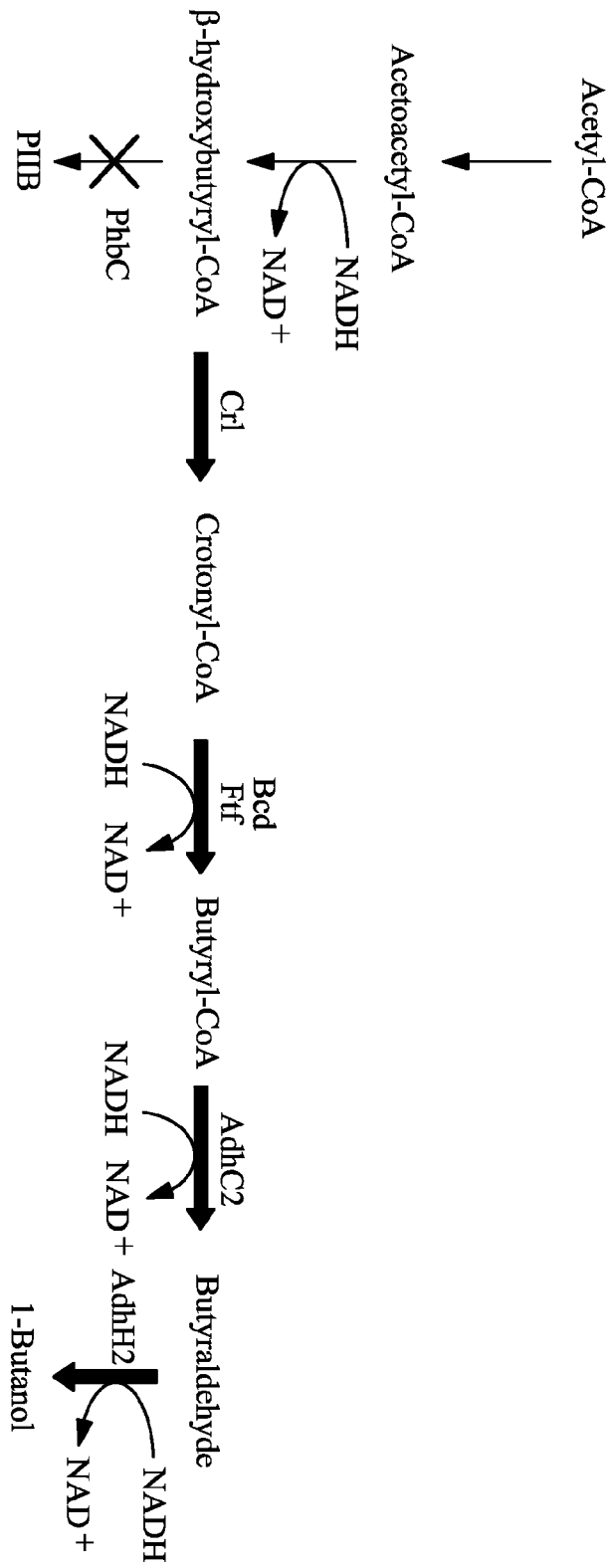
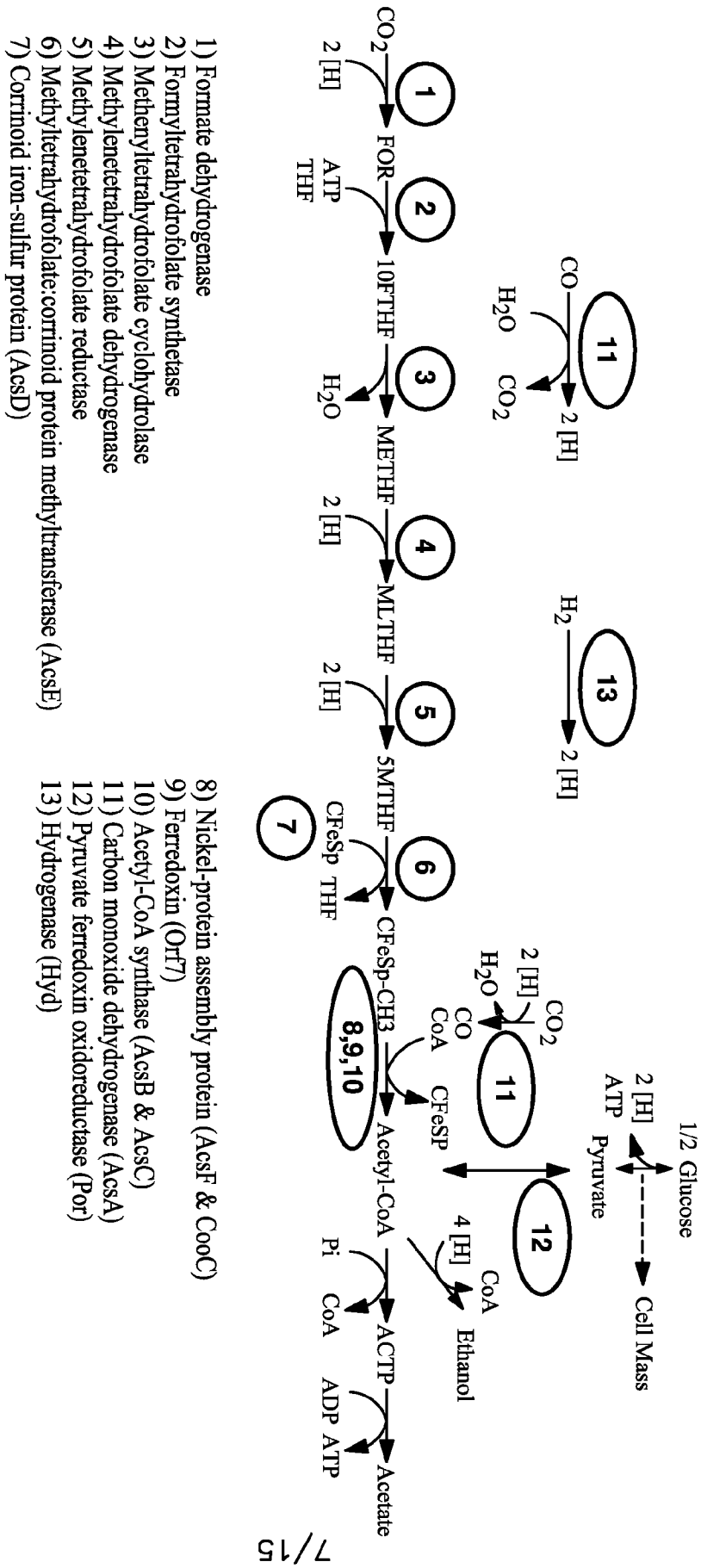

FIG. 5



7/15

FIG. 6

- 1) Methanol methyltransferase (MtaB)
- 2) Corrinoid protein (MtaC)
- 3) Methyltetrahydrofolate:corrinoid protein methyltransferase (MtaA)
- 4) Methyltetrahydrofolate:corrinoid protein methyltransferase (AcSE)
- 5) Corrinoid iron-sulfur protein (AcSD)
- 6) Nickel-protein assembly protein (AcSF & CooC)
- 7) Ferredoxin (Orf7)
- 8) Acetyl-CoA synthase (AcSB & AcSC)
- 9) Carbon monoxide dehydrogenase (AcSA)
- 10) Pyruvate ferredoxin oxidoreductase (Por)
- 11) Hydrogenase (Hyd)

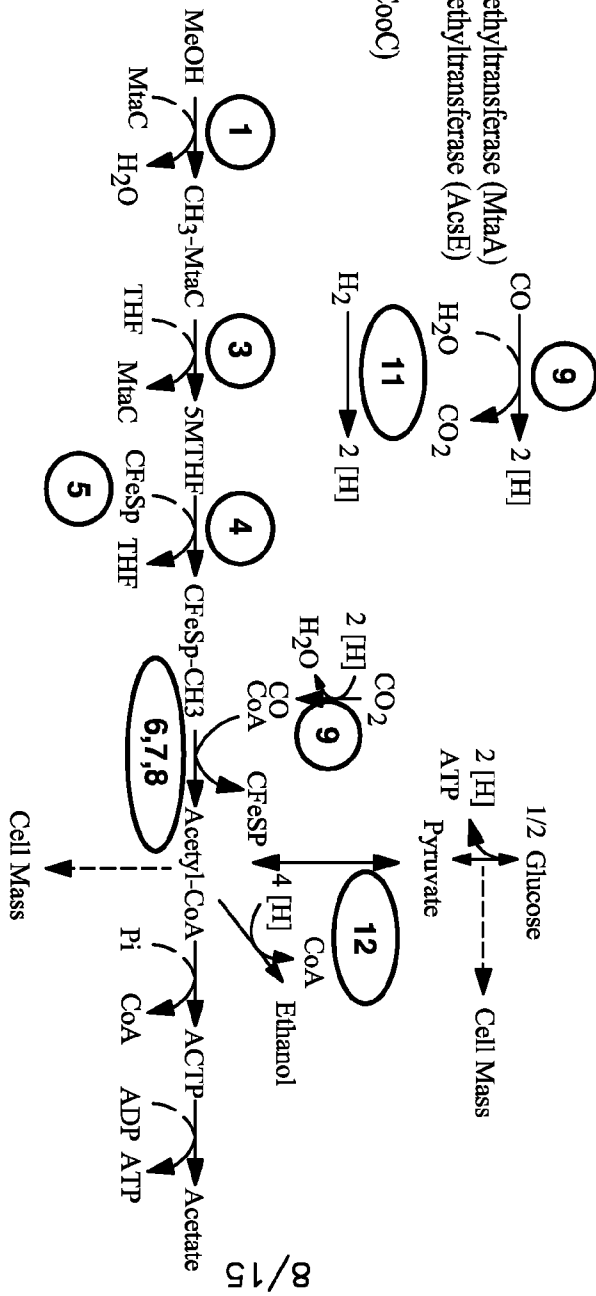

FIG. 7

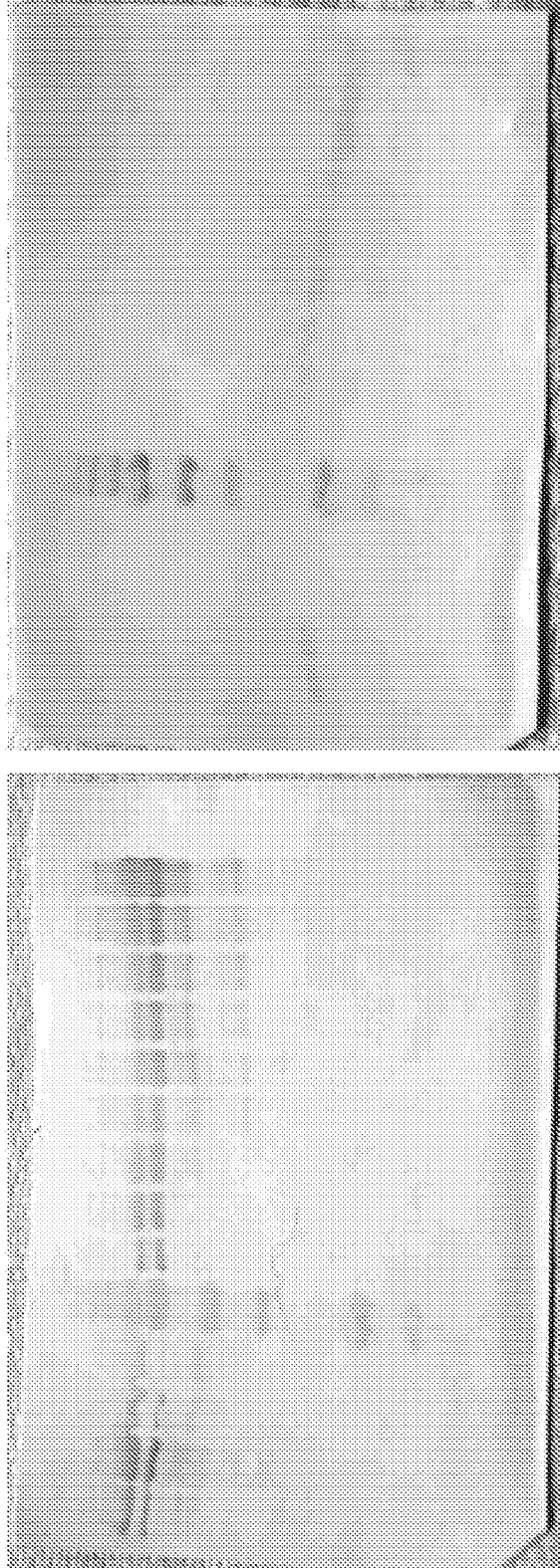

FIG. 9

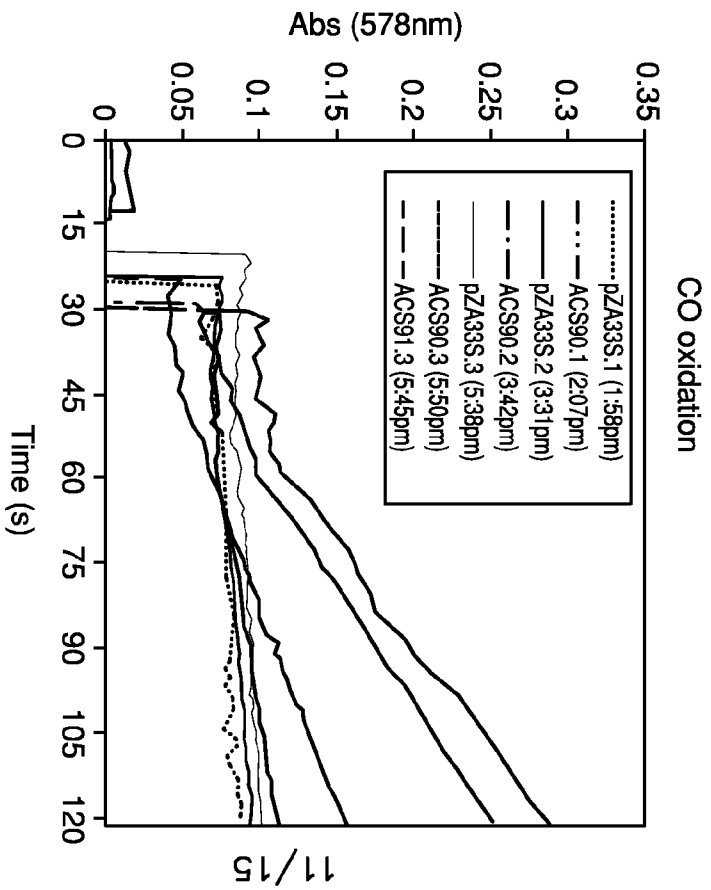
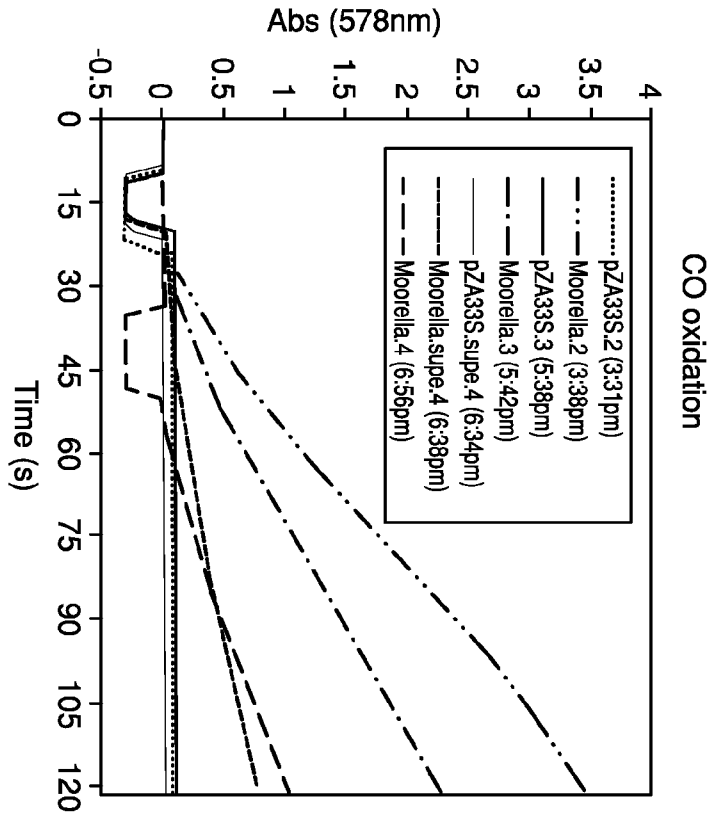

FIG. 10

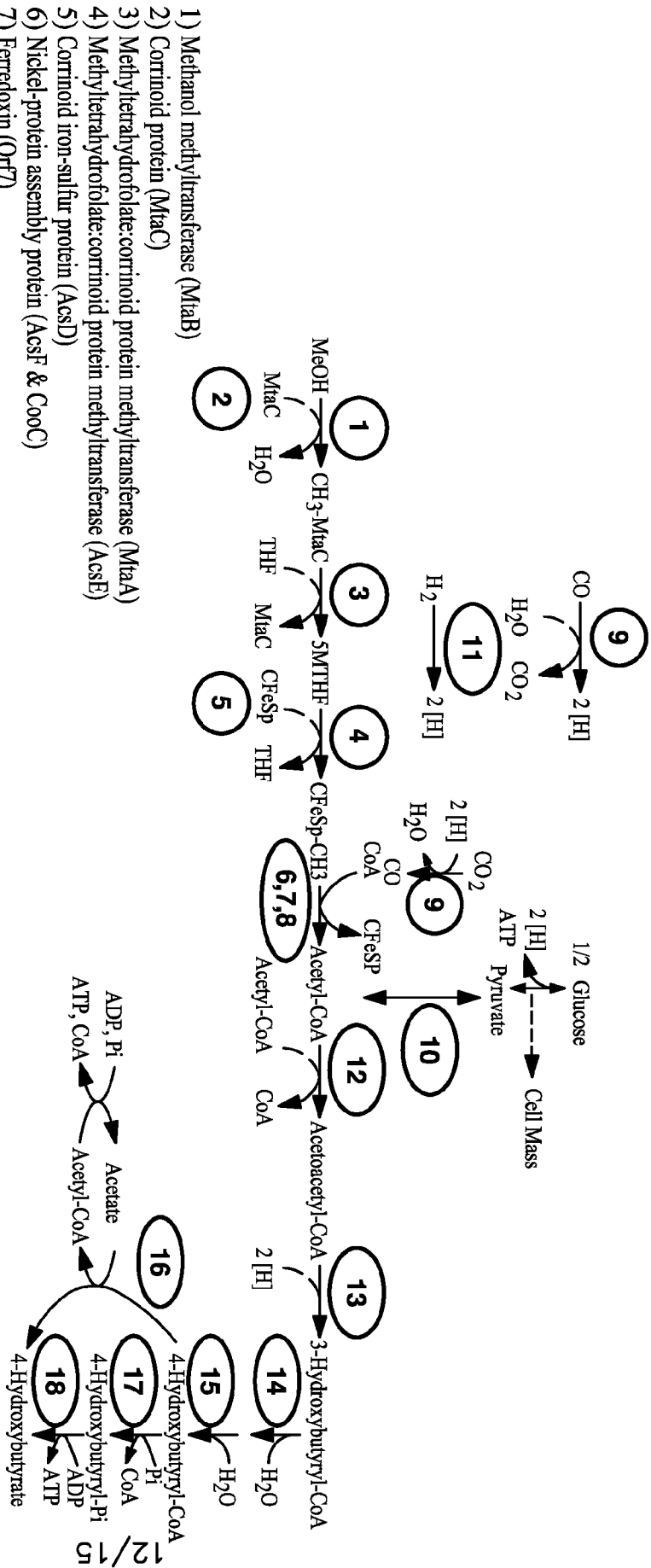

FIG. 11

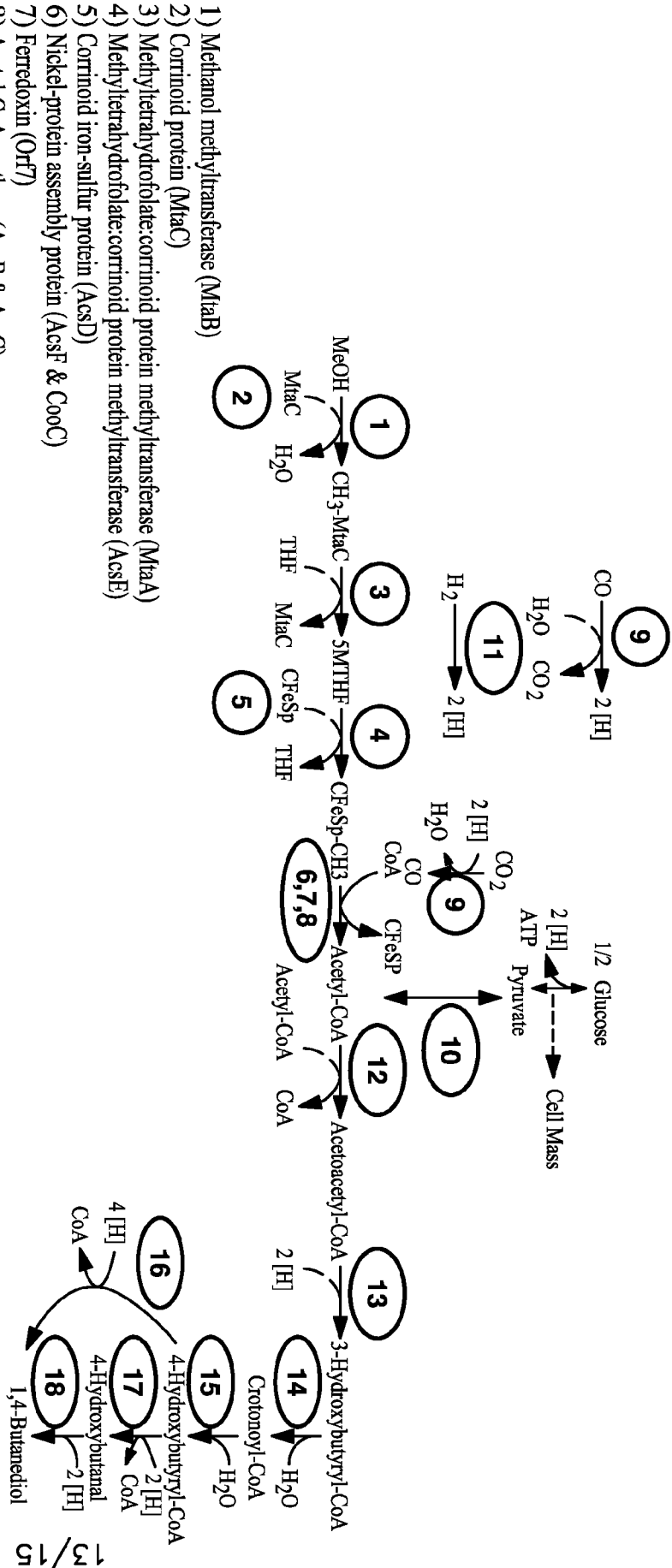

FIG. 12

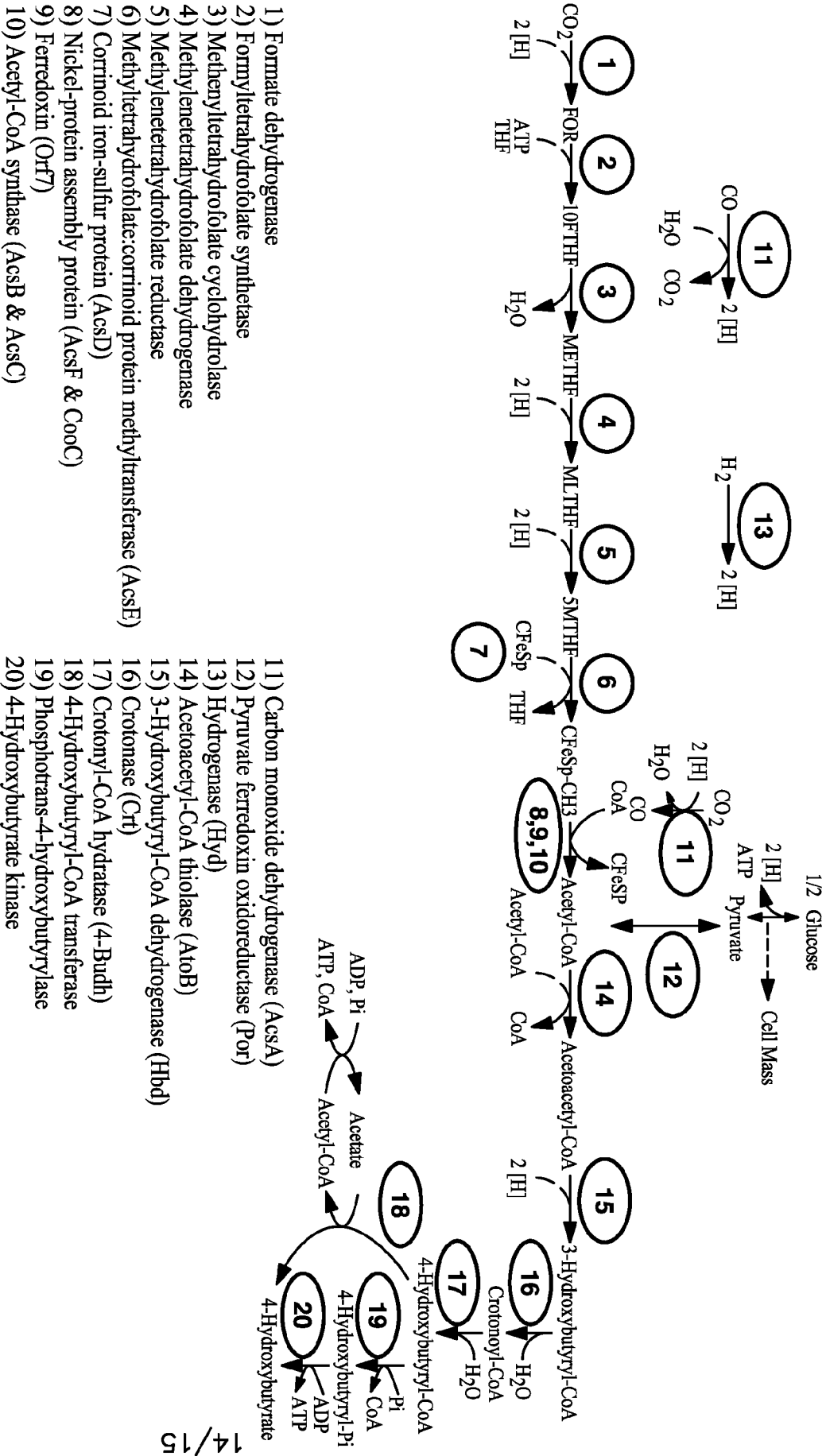

FIG. 13

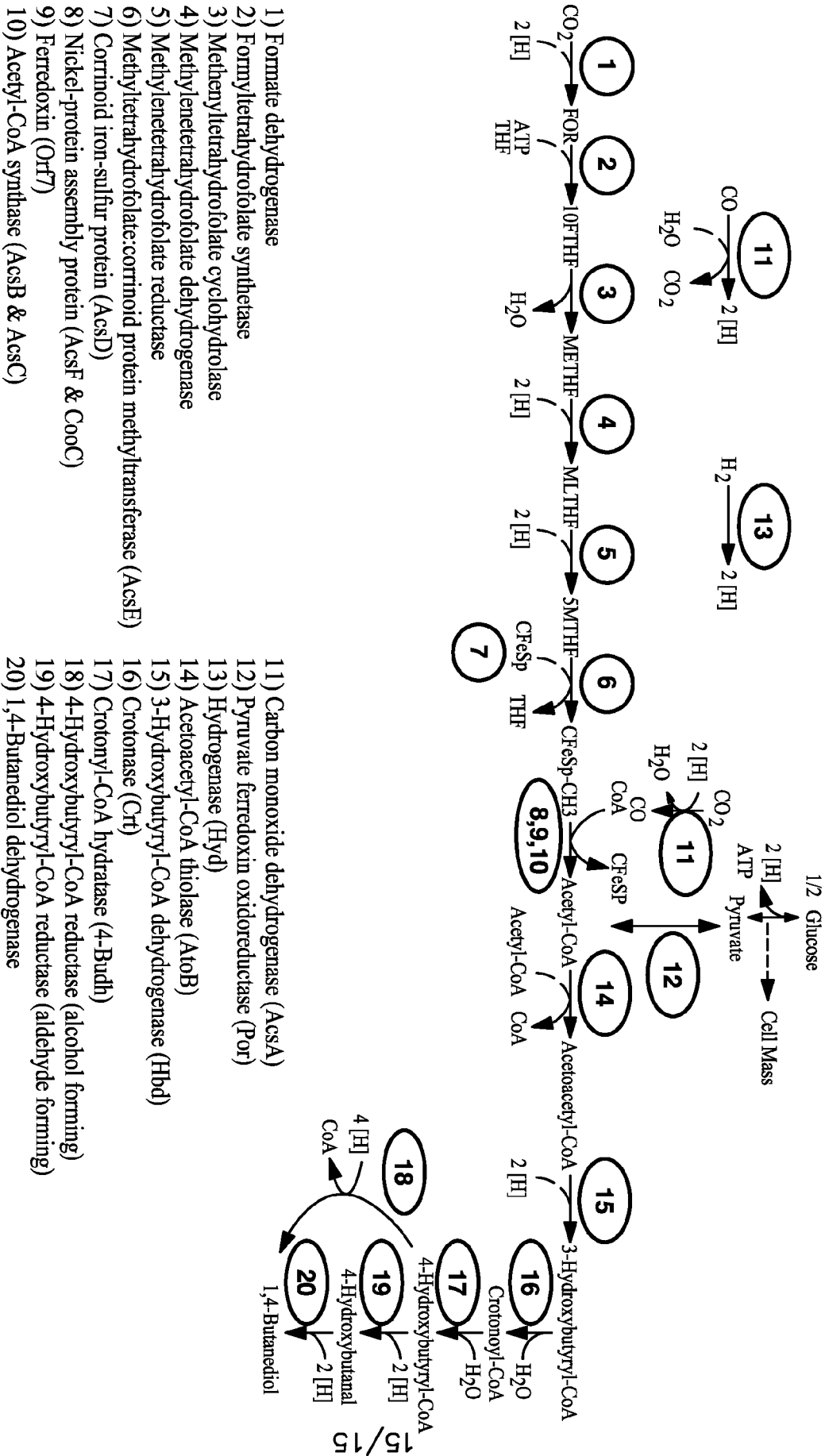

FIG. 14

INTERNATIONAL SEARCH REPORT

International application No.

PCT/US 09/31737

A. CLASSIFICATION OF SUBJECT MATTER

IPC(8) - C12N 1/20; C12P 21/06; C12P 1/00 (2009.01)

USPC - 435/252.3; 435/69.1; 435/41

According to International Patent Classification (IPC) or to both national classification and IPC

B. FIELDS SEARCHED

Minimum documentation searched (classification system followed by classification symbols)
USPC - 435/252.3; 435/69.1; 435/41Documentation searched other than minimum documentation to the extent that such documents are included in the fields searched
USPC - 435/41, 435/69.1, 435/87, 435/88, 435/89, 435/136, 435/140, 435/471, 435/190, 435/193, 435/252.3\$Electronic data base consulted during the international search (name of data base and, where practicable, search terms used)
WEST (PGPB, USPT, USOC, EPAB, JPAB); Google
Exogenous, CO, carbon monoxide, CO₂, carbon dioxide, H₂, hydrogen, acetyl, coenzyme A, CoA, protein, nucleic acid, acetogenic, acetogenesis, synthesis gas, between, wood pathway, c. thermoaceticum, ten, methyltransferase, and nitrate

C. DOCUMENTS CONSIDERED TO BE RELEVANT

Category*	Citation of document, with indication, where appropriate, of the relevant passages	Relevant to claim No.
Y	Wood. "Life with CO or CO ₂ and H ₂ as a source of carbon and energy". 01 February 1991 (01.02.1991), The Federation of American Societies For Experimental Biology Journal, Vol. 5, pg. 156-163; especially pg 156 col 1 para 1; pg 157 col 2 para 1; pg 158 col 2 para 3; and pg 160 col 1 para 1-3, col 2 para 2, and Fig. 7	1-69
Y	Loke et al. "Active acetyl-CoA synthase from Clostridium thermoaceticum obtained by cloning and heterologous expression of acsAB in Escherichia coli" 07 November 2000 (07.11.2000), Proceedings of the National Academy of Sciences, vol. 97, no. 23, pg 12530?12535; especially pg 12530 col 1 para 1-2; and pg 12534 col 1 para 2	1-69
Y	US 6,117,658 A (Dennis et al.) 12 September 2000 (12.09.2000), col 4 ln 50-59,	1-69
Y	Grethlein et al. "Bioprocessing of coal-derived synthesis gases by anaerobic bacteria" 01 December 1992 (01.12.1992), Trends In Biotechnology, vol. 10, pp. 418-423; especially pg 418 col 1 para 1-2; and pg 420 col 1 para 1	4-7, 14-17, 26 and 52
Y	Ljungdahl, "The Autotrophic Pathway Of Acetate Synthesis In Acetogenic Bacteria" 01 October 1986 (01.10.1986), Annual Review of Microbiology, Vol. 40, pg 415-50; especially pg 423 para 3; pg 425 para 1; pg 426 para 4; pg 427 Table 2; pg 431 para 2; and pg 438 para 2	13, 17, 20, 30-39 and 53-62
Y	Ragsdale et al. "Nitrate-Dependent Regulation of Acetate Biosynthesis and Nitrate Respiration by Clostridium thermoaceticum", 01 March 1999 (01.03.1999) Journal of Bacteriology, Vol. 181, pg 1489?1495; especially pg 1492 col 2 para 2	69

 Further documents are listed in the continuation of Box C.

* Special categories of cited documents:

"A" document defining the general state of the art which is not considered to be of particular relevance

"E" earlier application or patent but published on or after the international filing date

"L" document which may throw doubts on priority claim(s) or which is cited to establish the publication date of another citation or other special reason (as specified)

"O" document referring to an oral disclosure, use, exhibition or other means

"P" document published prior to the international filing date but later than the priority date claimed

"T" later document published after the international filing date or priority date and not in conflict with the application but cited to understand the principle or theory underlying the invention

"X" document of particular relevance; the claimed invention cannot be considered novel or cannot be considered to involve an inventive step when the document is taken alone

"Y" document of particular relevance; the claimed invention cannot be considered to involve an inventive step when the document is combined with one or more other such documents, such combination being obvious to a person skilled in the art

"&" document member of the same patent family

Date of the actual completion of the international search

21 May 2009 (21.05.2009)

Date of mailing of the international search report

23 JUN 2009

Name and mailing address of the ISA/US

Mail Stop PCT, Attn: ISA/US, Commissioner for Patents
P.O. Box 1450, Alexandria, Virginia 22313-1450

Facsimile No. 571-273-3201

Authorized officer:

Lee W. Young

PCT Helpdesk: 571-272-4300
PCT OSP: 571-272-7774

INTERNATIONAL SEARCH REPORT

International application No.

PCT/US 09/31737

Box No. II Observations where certain claims were found unsearchable (Continuation of item 2 of first sheet)

This international search report has not been established in respect of certain claims under Article 17(2)(a) for the following reasons:

1. Claims Nos.:
because they relate to subject matter not required to be searched by this Authority, namely:

2. Claims Nos.:
because they relate to parts of the international application that do not comply with the prescribed requirements to such an extent that no meaningful international search can be carried out, specifically:

3. Claims Nos.:
because they are dependent claims and are not drafted in accordance with the second and third sentences of Rule 6.4(a).

Box No. III Observations where unity of invention is lacking (Continuation of item 3 of first sheet)

This International Searching Authority found multiple inventions in this international application, as follows:

Group I: Claims 1-69 are drawn to either a non-naturally occurring microorganism having an acetyl-CoA pathway or a methyltetrahydrofolate pathway (i.e. Wood pathway), or a method for producing acetyl-CoA.

Group II: Claims 70- 100, and 131-161 are drawn to either a non-naturally occurring microbial organism having a 4-hydroxybutyrate pathway, or a method for producing 4-hydroxybutyrate.

Group III: Claims 101-130, and 162-191 are drawn to either a non-naturally occurring microbial organism having a 1,4-butanediol pathway, or a method for producing 1,4-butanediol.

*****continued on extra sheet*****

1. As all required additional search fees were timely paid by the applicant, this international search report covers all searchable claims.
2. As all searchable claims could be searched without effort justifying additional fees, this Authority did not invite payment of additional fees.
3. As only some of the required additional search fees were timely paid by the applicant, this international search report covers only those claims for which fees were paid, specifically claims Nos.:
4. No required additional search fees were timely paid by the applicant. Consequently, this international search report is restricted to the invention first mentioned in the claims; it is covered by claims Nos.:
Group I: Claims 1-69

Remark on Protest

- The additional search fees were accompanied by the applicant's protest and, where applicable, the payment of a protest fee.
- The additional search fees were accompanied by the applicant's protest but the applicable protest fee was not paid within the time limit specified in the invitation.
- No protest accompanied the payment of additional search fees.

INTERNATIONAL SEARCH REPORT

International application No.

PCT/US 09/31737

Continued from Box III (Unity of Invention is Lacking)

The groups listed above do not relate to a single general inventive concept under PCT Rule 13.1 because under PCT Rule 13.2, they lack the same or corresponding special technical features for the following reasons.

The technical feature linking the above listed groups a non-naturally occurring microorganism having a pathway pathway comprising acetyl-CoA as an intermediate or product. However, this does not represent an improvement over the prior art of US 6,117,658 Ato Dennis et al., a non-naturally occurring microorganism having a pathway comprising acetyl-CoA as an intermediate or product (col 3, ln 27-39 and fig 3). Although Groups II and III are additionally linked by a pathway comprising 4-hydroxybutyrate (1,4-butanediol and 4-hydroxybutyrate are in the same pathway), this linking technical feature is also taught by Dennis (col 3, ln 27-39).

Accordingly, unity of invention is lacking under PCT Rule 13.2 because the groups do not share a same or corresponding special technical feature providing a contribution over the prior art.