



Europäisches Patentamt  
European Patent Office  
Office européen des brevets



(11) **EP 0 703 341 B1**

(12) **EUROPEAN PATENT SPECIFICATION**

(45) Date of publication and mention  
of the grant of the patent:  
**03.05.2000 Bulletin 2000/18**

(51) Int Cl.7: **E05G 1/06**

(21) Application number: **95830393.5**

(22) Date of filing: **25.09.1995**

(54) **Safety box assembly**

Sicherheitsbehälterzusammenbau

Assemblage de coffre-fort

(84) Designated Contracting States:  
**AT CH DE ES FR LI**

(72) Inventor: **Domenicone, Rocco, Co. M.P.E.T. s.r.l.**  
**I-00177 Roma (IT)**

(30) Priority: **26.09.1994 IT RM940611**

(74) Representative: **Iannone, Carlo Luigi et al**  
**Ing. Barzanò & Zanardo Roma S.p.A.**  
**Via Piemonte, 26**  
**00187 Roma (IT)**

(43) Date of publication of application:  
**27.03.1996 Bulletin 1996/13**

(73) Proprietor: **Co.M.P.E.T. S.r.l.**  
**00177 Roma (IT)**

(56) References cited:  
**EP-A- 0 051 048** **EP-A- 0 140 839**

**EP 0 703 341 B1**

Note: Within nine months from the publication of the mention of the grant of the European patent, any person may give notice to the European Patent Office of opposition to the European patent granted. Notice of opposition shall be filed in a written reasoned statement. It shall not be deemed to have been filed until the opposition fee has been paid. (Art. 99(1) European Patent Convention).

## Description

**[0001]** The present invention relates to a safety box assembly.

**[0002]** More particularly, the invention concerns an assembly allowing to include a rather high number of safety boxes in a limited space, further allowing the individual managing of the same in the maximum safety and flexibility conditions.

**[0003]** With the solution proposed according to the present invention an automatic management system for safety boxes is provided, said system allowing to the user to autonomously manage a safety box space contained within an armour-plated structure placed in the opening of a suitable space of a bank, post office, railway station, hotel, etc.

**[0004]** As it is well known, up today the bank boxes were called "safety boxes" since they were placed within the vault of the bank, a place that was deemed to be inviolable.

**[0005]** However, many cases occurred of criminals that got in the vault and that forced all the boxes, often using very simple tools, hidden to the view of the guards and people.

**[0006]** In order to face these events, safety boxes contained within safes provided in the vault have been adopted.

**[0007]** In any case, this kind of solution involves the very long routine of accompanying the client within the vault, and opening and closing the box with two keys, so that the management of the safety boxes is not so much advantageous.

**[0008]** Recently, the expansionist politic of the banks had the aim of reaching a more widespread presence on the market, this aim to be reached by the opening of little bank counters, called "light bank counters", that are able to offer the greater number of "self service" duties, thus reducing the work of the personnel just to the consulting and the acquisition of new clients.

**[0009]** In an attempt to speed up and modernise all the services, self-management attempts have been made also for the safety box service.

**[0010]** The solution adopted provides traditional boxes placed in a suitable room from which robotized mechanical arms remove and transport the boxes near to the space destined to the client.

**[0011]** However, these systems, that are enough complicated, are not convenient as far as the management is concerned and furthermore requires large spaces and great investment difficult to be amortized.

**[0012]** The solution proposed according to the present invention is included in this context, said solution allowing to overcome the above mentioned drawbacks, giving at the same time a modern, safe and easily self-manageable service that occupies a little space and requires investments amortizable in a short time.

**[0013]** EP-A-0140839, which is the most pertinent prior art document, discloses a safety box having the fea-

tures included in the precharacterizing portion of the enclosed claim 1.

**[0014]** The safety box assembly according to the invention is characterized by the features included in the characterizing portion of claim 1.

**[0015]** It is therefore specific object of the present invention a safety box assembly comprising a cylindrical revolving carrousel divided in sectors with a box bearing opening, motion means for an access door and computer means, said assembly being characterized in that said cylindrical revolving carrousel is made up of at least one floor, in that each floor comprises at least a false armour-plated opening and in that it further comprises an outer armour plated structure, provided with a number of movable doors corresponding to the number of floors provided on the carrousel, in order to allow the access to the box bearing openings of each floor, a control terminal allowing to the user to interact with the assembly and motion means for the carrousel floors, said computer means being provided with a suitable software, to control said motion means on the basis of the instructions introduced within the control terminal.

**[0016]** According to the invention, said carrousel comprises a plurality of floors that can be all provided with equal sectors with box bearing opening or they can be realized with different sectors, so that the carrousel has safety boxes of different sizes, said access doors being provided in number and sizes corresponding to the floors and to the kind of openings provided in each floor.

**[0017]** Still according to the invention, said sectors with box bearing opening provide fixed boxes or removable boxes that can be introduced within the opening.

**[0018]** Preferably, each one of said boxes is provided with a safety lock of the expansion piles kind.

**[0019]** Said false opening of each floor is preferably closed by a steel plate.

**[0020]** The armour-plated structure is preferably comprised of a steel frame, with an internally bolted panels and with an armour-plated door for the access to the carrousel for its maintenance, the motion means of the carrousel being provided above the armour-plated structure.

**[0021]** According to a preferred embodiment of the assembly according to the invention, each one of said doors is moved by a ratiomotor connected with said computer means, provided with safety means locking the closure of the door in case of any impediment.

**[0022]** Particularly, said safety means can be made up of a spring and release joint.

**[0023]** Further, in correspondence of each one of said doors further safety means can be provided, particularly a photoelectric cell.

**[0024]** The control terminal, directly connected to the computer means, will preferably comprise a keyboard, and/or a magnetic card reader and/or a display.

**[0025]** Still according to the invention, said motion means of the carrousel can be comprised of a ratiomotor, connected with the rotation axis of the carrousel, by

a gear and chain system and an electromechanical decoder, a control logic card and safety system control cards.

**[0026]** Preferably, according to the invention, the access to the safety box of the user is subordinated to the introduction of three codes, one of which is directly set out by the user, the assembly providing that each time an operation is finished the armour-plated false opening is brought in correspondence of the relevant door.

**[0027]** The present invention will be now described for illustrative but not limitative purposes according to its preferred embodiments, with particular reference to the figures of the enclosed drawings, wherein:

figure 1 is a perspective view of a safety box assembly according to the invention;

figure 2 shows the assembly of figure 1 with the access armour-plated door open;

figure 3 shows the assembly of figure 1 with the upper portion broken away; and

figure 4 shows the assembly of figure 1 exploded.

**[0028]** Making reference to the figures of the enclosed drawings, it can be noted that the safety box assembly, generically indicated with the reference number 1, is comprised of a steel structure sheathed with armour-plated panels.

**[0029]** Said armour-plated panels are internally fixed by bolts so that externally it is impossible to act on the bolts to force the assembly 1.

**[0030]** Within the assembly 1 a cylindrical carrousel 2 provided with more than one floor is housed, said carrousel being divided in sectors - openings suitable to contain the safety boxes 3, as well as a row of false openings 4, that will be described in greater detail in the following.

**[0031]** The access to the carrousel 2 is possible through an access armour-plated door 5.

**[0032]** Each one of the safety boxes is provided with a frontal element having a safety lock with vertical expansion piles.

**[0033]** One of the walls of the steel structure, specifically the wall 7, provides a row of superimposed access doors 8, in order to be able to have access to the single boxes 3, according to the formality that will be described in the following. Always on this wall 7, a keyboard 9 with display or control terminal is provided.

**[0034]** Each one of the doors 8 is realized with vertical frames having an accident prevention photoelectric cell 10 that in case of any kind of obstacle, due for example to fingers or hands, stops the closure of the door that will go back in order to repeat after the operation.

**[0035]** In the upper part of the steel structure, the mechanisation and the managing electronic components of the system are contained.

**[0036]** Particularly, in the embodiment shown in the figure, a ratiomotor 11, for the motion of the rotation axis 12 of the carrousel 2, by gears 13 connected by a chain,

is shown.

**[0037]** By the reference 14 an electromechanical decoder is indicated, while by the reference 15 the PLC logic card is indicated and with the reference 16 the safety system cards. The axis 12 of the carrousel 2 rotates on rugged step bearings.

**[0038]** Coming now to describe in greater detail the steel structure, it comprises a strong steel frame 17, upon which panels are mounted, said panels being, as already said, innerly fixed by bolts.

**[0039]** The armour-plated door 5 allows to access within the structure to make the maintenance of the opening automatism of the outer doors 8.

**[0040]** The sectors - openings for the safety boxes 3 have a trapezoidal shape and are placed on different floors of the revolving carrousel 2. Obviously, the number of the floors can be varied and the same floors can all have the same height or different heights according to the cases, with the number of sectors for each floor variable in function of the needing and of the kind of box; further, also the boxes 3 can be all the same or they can be different.

**[0041]** The false opening 4 sector of the floor cannot be used as safety box bearing sector and is frontally closed by a steel plate.

**[0042]** In the solution shown for illustrative but not limitative purposes in the enclosed figures, each floor is divided in 24 sectors, 23 of which form the box 3 openings, while the last one is the safety sector that will be placed behind the row of superimposed doors 8 when the assembly 1 is in the rest position.

**[0043]** The dimensions of the doors 8 correspond to those of the box 3 bearing openings of the relevant whole floor. The door 8, made up of a very thick steel plate, opens and closes laterally sliding within the wall 7, by an automated and software managed control. The mechanisation of each door 8 is comprised of an endless screw operated by a ratiomotor 19 by a spring and release joint 20.

**[0044]** When the assembly 1 according to the invention is in the rest position, none of the box 3 bearing openings is placed behind the row of superimposed doors 8, since the false openings 4 row closed by a steel plate is provided behind said doors 8.

**[0045]** Each box 3 is provided with a safety lock 6 having vertical offset expansion piles, said piles fixing in the structure of the carrousel 2. Therefore, each box 3 opening can be considered as a little safe.

**[0046]** The motor is operated by the PLC logic card 15 by a command sent by the personal computer, after that the computer has checked that the data digitised on the keyboard 9 correspond to the combination of the three data previously stored within its memory.

**[0047]** The electromechanical decoder 14 by means of a position reader 21, allows the stop of the motor and thus the motion of the carrousel 2, when the sector indicated by the user by the control terminal 9 is placed in correspondence of the row of doors 8 opening on the

front side of the wall 7.

**[0048]** Contemporaneously, by the stop of the motor, the PLC logic card 15 operates the ratiomotor 19 corresponding to the indicated floor, said ratiomotor opening, by an endless screw 18, the door 8 horizontally slidable.

**[0049]** When the user of the service pushes on the keyboard 9 the end operation push button, the logic card 15, upon indication of the personal computer, starts again the ratiomotor 19 to close again the door 8 by the endless screw 18.

**[0050]** As already said, said screw 18 is connected with the axis of the ratiomotor 19 by means of a spring and release joint 20 (clutch), moving in an "idle" position in case during the closure the door 8 encounters any obstacle; during the release motion of the joint (idle clutch) also a microswitch inverting the rotation direction of the ratiomotor 19 is operated.

**[0051]** In this way, any obstacle encountered during the closure of the door 8, by the action on the spring and bringing the joint in the release point (idle) and contemporaneously inverting the rotation direction of the ratiomotor 19, the door 8 is brought back in the opening position. Contemporaneously, also the photoelectric cell 10 operates locking and inverting the motion direction of the ratiomotor 19.

**[0052]** After three attempts, if the obstacle has not been removed, the system gives an alarm.

**[0053]** After the closure of the door 8, the personal computer by the PLC logic card 15 starts again the ratiomotor 11 which moves the carrousel 2 bringing the safety sector again behind the row of doors 8, i.e. the sector with the false openings 4 closed by the steel plate.

**[0054]** All the working of the assembly according to the present invention is managed by the software which, by a personal computer (not shown) and the logic card 15 (PLC) makes the operations being activated after having recognised the data set out by the user on the keyboard 9 with display.

**[0055]** All the managing sector of the safety box assembly, except for the keyboard, is provided in the upper part of the steel structure, well separated from the below sector containing the carrousel 2 with the box 3 bearing openings, so that any eventual maintenance intervention (excluded the replacement of the ratiomotors 19 for the automation of the doors 8) can be carried out without having access to the inner sector and thus without the need of opening the armour-plated door 5.

**[0056]** The management modes of the assembly that will be now described are illustrative, being understood that different operative modes can be set out, with a different software, without departing from the scope of the invention.

**[0057]** To the user renting the box 3 opening an access pre-code is given, said code being then deleted and replaced by the personal secret code.

**[0058]** The user, after he knows said pre-code and has the key of the safety lock 6 of the box rent, has ac-

cess to the system by the following operations:

- on the keyboard 9 with display provided on the wall 7 he digits the number of the box allotted, the number of the floor of the carrousel 2 where the box 3 is provided and the precode he has received;
- by the display 9, the user is requested to digit a personal code that will replace the access pre-code and that, from now on, will allow him the self-management of its box 3 opening; (the system memorises the secret code set out by the user, coupling the same with the box 3 number and with the floor number, working out a specific secret code);
- the user checks on the display of the control terminal 9 the exactness of the set out data and pushes the operation confirmation push button.

**[0059]** From now on, only if the system recognises that the three data set out by the user correspond to the previously stored combination and coupled with the self-worked out fourth code, will operate bringing the box 3 opening called in correspondence of the door 8, that will open.

**[0060]** The user is able to open the box 3 by the key he already has.

**[0061]** Once finished the withdrawal and/or deposit operations, the user closes the box 3, withdraws the key and pushes on the end of operation button of the keyboard 9.

**[0062]** The system provides to close again the door 8 and to bring back the user box in the safe position, leaving false openings 4 provided with steel plate behind the doors 8.

**[0063]** In case the user lingers in the operations other than a reasonable period of time, varying on the basis of the specific needing, a warning horn and or a light signaller put into evidence to the user that the time allowed for the operations is lapsed.

**[0064]** If the user after having closed his box 3 opening, forgets to push the end of the operation push button, once passed the time mentioned above, the system will provide to close the door in any case and to bring back the box 3 opening in a safe position.

**[0065]** Further, the management software makes a complete control of the system every 10 minutes, indicating by an alarm eventual working irregularities. This alarm system, even remote, operates in any case for any irregularity.

**[0066]** The solution proposed according to the present invention allows to reach a remarkable series of important advantages with respect to the solutions available up to now.

**[0067]** Particularly, the safety box assembly according to the invention allows to obtain the following advantages:

- provide a high number of box openings within a small sized armour-plated structure;

- it is possible to provide it in "view", although in a space reachable only by a personal card like Bancomat, so that it is impossible for the criminals to work hidden by the walls and in any case without been seen by the guards;
- it is impossible to contemporaneously have at disposal all the boxes. In fact, they must specifically called and are provided behind the access doors one each time;
- it is impossible to have access to the single boxes without the electronic consent obtainable by the digitisation of codes, one of which is secret, directly set out by the user;
- difficulty to unhinge the access doors to the boxes, said doors being realized by a steel plate with high thick, laterally slidable within the armour-plated structure and without any point or projection to be used and behind which in the rest position no safety box is provided, but a further steel plate;
- difficulty to unhinge the opening or box doors that practically are little safes provided with safety lock having offset, vertically expansible piles, which fix within the armour-plated structure;
- possibility to give a new "daily" service", i.e. the temporary withdrawal and transport of the box out of the bank. For example: withdrawal of a suitably sized safety box containing the jewels to be used for one night, or important documents to be consulted during the day, said box perfectly conforming as a safe door to an armour-plated opening provided in a wall at home or in the office.

**[0068]** The present invention has been described for illustrative but not limitative purposes according to its preferred embodiments, but it is to be understood that variation and/or modifications can be introduced by those skilled in the art without departing from the relevant scope as defined in the enclosed claims.

### Claims

1. Safety box assembly (1) comprising a cylindrical revolving carrousel (2) divided in sectors with a box (3) bearing opening, motion means for an access door (5) and computer means, said assembly being characterized in that said cylindrical revolving carrousel is made up of at least one floor, in that each floor comprises at least a false armour-plated opening (4) and in that it further comprises an outer armour plated structure, provided with a number of movable doors (8) corresponding to the number of floors provided on the carrousel (2), in order to allow the access to the box bearing openings of each floor, a control terminal allowing to the user to interact with the assembly and motion means for the carrousel floors, said computer means being provided with a suitable software, to control said motion

means on the basis of the instructions introduced within the control terminal.

2. Safety box assembly (1) according to claim 1, characterized in that said carrousel (2) comprises a plurality of floors that can be all provided with equal box (3) bearing opening sectors or they can be realized with different sectors, so that the carrousel (2) has safety boxes (3) of different sizes, said access doors (8) being provided in number and sizes corresponding to the floors and to the kind of opening provided in each floor.
3. Safety box assembly (1) according to one of the preceding claims, characterized in that said sectors with box (3) bearing opening provide fixed boxes (3).
4. Safety box assembly (1) according to one of the claims 1 or 2, characterized in that said sector with box (3) bearing opening provide removable boxes (3) that can be introduced within the opening.
5. Safety box assembly (1) according to one of the preceding claims, characterized in that said boxes (3) are provided with a safety lock of the expansion piles kind.
6. Safety box assembly (1) according to one of the preceding claims, characterized in that said false opening (4) of each floor is closed by a steel plate.
7. Safety box assembly (1) according to one of the preceding claims, characterized in that the armour-plated structure is comprises of a steel frame (17), with an internally bolted panels and with an armour-plated door for the access to the carrousel for its maintenance, the motion means (11, 12, 13, 14, 15, 16) of the carrousel being provided above the armour-plated structure.
8. Safety box assembly (2) according to one of the preceding claims, characterized in that each one of said doors (8) is moved by a ratiomotor 19 connected with said computer means, provided with safety means locking the closure of the door (8) in case of any impediment.
9. Safety box assembly (1) according to one of the preceding claims, characterized in that said safety means are made up of a spring and release joint (20).
10. Safety box assembly (1) according to claim 9, characterized in that in correspondence of each one of said doors (8) further safety means are provided, particularly a photoelectric cell (10).

11. Safety box assembly (1) according to one of the preceding claims, characterized in that the control terminal, directly connected to the computer means, comprises a keyboard (9), and/or a magnetic card reader and/or a display.
12. Safety box assembly (1) according to one of the preceding claims, characterized in that said motion means of the carrousel are comprised of a ratiomotor (11), connected with the rotation axis (12) of the carrousel (2), by a gear (13) and chain system and an electromechanical decoder (14), a control logic card and safety system control cards (16).
13. Safety box assembly (1) according to one of the preceding claims, characterized in that the access to the safety box of the user is subordinated to the introduction of three codes, one of which is directly set out by the user, the assembly providing that each time an operation is finished the armour-plated false opening is brought in correspondence of the relevant door.

#### Patentansprüche

1. Sicherheitsfächeranordnung (1) mit einem zylinderförmigen Drehkarussell (2), das in Abschnitte mit Fächer (3) enthaltenden Öffnungen unterteilt ist, Betätigungsmitteln für eine Zugangstür (5) und mit Rechnermitteln, dadurch gekennzeichnet, dass das genannte zylinderförmige Drehkarussell aus mindestens einem Stock besteht, das jeder Stock mindestens eine falsche gepanzerte Öffnung (4) aufweist und dass es ausserdem einen gepanzerten äusseren Bauwerk enthält, der mit einer der Anzahl von Stocken entsprechende Anzahl von beweglichen Türen (8) versehen ist, um den Zugang zu den die Fächer enthaltenden Öffnungen eines jeden Stockes zu gestatten, und mit einer Steueranordnung für Benützer zur Steuerung des Karussells und der Stellmittel zur Verstellung der Karussell-Stockwerke, wobei die genannten Rechnermittel mit angebrachten Softwarestücken versehen sind, die zur Steuerung der genannten Stellmittel auf Grund der in die Steueranordnung eingeführten Anweisungen dienen.
2. Sicherheitsfächeranordnung (1) nach Anspruch 1, dadurch gekennzeichnet, dass das genannte Karussell (2) eine Mehrzahl von Stockwerken aufweist, die mit Abschnitten von Öffnungen für gleiche Fächer (3) oder mit unterschiedlichen Abschnitten versehen sind, so dass das Karussell (2) auch Sicherheitsfächer (3) unterschiedlicher Grössen haben kann, wobei die genannten Zugangstüre in einer den Stockwerken und der Art der am jeden Stockwerk vorgesehenen Öffnungen entsprechenden Anzahl

und Grösse angeordnet sind.

3. Sicherheitsfächeranordnung (1) nach je einem der vorhergehenden Ansprüche, dadurch gekennzeichnet, dass die vorgenannten Abschnitte mit Sicherheitsfächer (3) enthaltenden Öffnungen mit festen Fächer (3) versehen sind.
4. Sicherheitsfächeranordnung (1) nach Ansprüche 1 oder 2, dadurch gekennzeichnet, dass die vorgenannten Abschnitte, mit Sicherheitsfächer (3) enthaltenden Öffnungen, mit abnehmbaren Fächer (3) versehen sind.
5. Sicherheitsfächeranordnung (1) nach je einem der vorhergehenden Ansprüche, dadurch gekennzeichnet, dass die vorgenannten Fächer (3) mit einem Sicherheitsschloss der Art mit Expansionsstäben versehen sind.
6. Sicherheitsfächeranordnung (1) nach je einem der vorhergehenden Ansprüche, dadurch gekennzeichnet, dass die genannte falsche Öffnung (4) jedes Stockwerkes mit einer Stahlplatte geschlossen ist.
7. Sicherheitsfächeranordnung (1) nach je einem der vorhergehenden Ansprüche, dadurch gekennzeichnet, dass das vorgenannte gepanzerte Ausenbauwerk einen Stahlrahmen (17) enthält, mit innerlich verschraubten Tafeln und einer gepanzerten Tür für den Zugang an das Karussell zur Wartung desselben, wobei die Stellmittel (11,12,13,14,15, 16) des Karussells oberhalb des gepanzerten Bauwerks angeordnet sind.
8. Sicherheitsfächeranordnung (1) nach je einem der vorhergehenden Ansprüche, dadurch gekennzeichnet, dass die vorgenannte Türe (8) durch einen mit den vorgenannten Rechnermitteln verbundenen Getriebe-Motor (19) betätigt wird, der mit Sicherheitsmitteln zur Verriegelung des Schlosses der Tür (8) im Bedarfsfall versehen ist.
9. Sicherheitsfächeranordnung (1) nach je einem der vorhergehenden Ansprüche, dadurch gekennzeichnet, dass die vorgenannten Sicherheitsmittel aus einer Feder- und Rastkupplung (20) bestehen.
10. Sicherheitsfächeranordnung (1) nach Anspruch 9, dadurch gekennzeichnet, dass zu jeder Tür (8) weitere Sicherheitsmittel, insbesondere eine photoelektrische Zelle (10), zugeordnet sind.
11. Sicherheitsfächeranordnung (1) nach je einem der vorhergehenden Ansprüche, dadurch gekennzeichnet, dass die mit den Rechnermitteln unmittelbar verbundene Steueranordnung eine Tastatur (9)

und/oder einen Leser für magnetische Karte oder Display enthält.

12. Sicherheitsfächeranordnung (1) nach je einem der vorhergehenden Ansprüche, dadurch gekennzeichnet, dass die genannten Stellmittel des Karussells mit einem Getriebemotor (11), der durch ein Getriebe (13) und eine Ketteanordnung mit der Drehachse (12) des Karussells (2) verbunden ist und mit einem elektromechanischen Entschlüssler, einer logischen Kontrollkarte und mit Sicherheitssystem-Kontrollkarten (16) versehen sind.
13. Sicherheitsfächeranordnung (1) nach je einem der vorhergehenden Ansprüche, dadurch gekennzeichnet, dass der Zugang zum Sicherheitsfach des Benützers durch die Einführung von drei Codeschlüsseln freigestellt wird, deren einer unmittelbar vom Benützer gebraucht wird, wobei die Anordnung so getroffen ist, dass am Ende einer Operation, die gepanzerte falsche Öffnung an die entsprechende Tür gebracht wird.

#### Revendications

1. Ensemble de coffres (1) comprenant un carrousel cylindrique tournant (2) divisé en secteurs ayant une ouverture avec un coffre (3), des moyens de déplacement pour une porte d'accès (5) et de moyens à computer, ledit ensemble étant caractérisé en ce que ledit carrousel cylindrique tournant consiste au moins d'un étage, en ce que chaque étage comprend une fausse ouverture blindée (4) et en ce que qu'il comprend en outre une structure extérieure blindée, munie d'un nombre des portes movable (8) correspondent au nombre des étages, afin de permettre l'accès à les ouvertures contenant les coffres de chaque étage, une gâchette consentant à l'utilisateur d'interagir avec l'ensemble et les moyens de déplacement des étages du carrousel, lesdits moyens à computer étant munis de software approprié pour contrôler lesdits moyens de déplacement sur la base des instructions introduites dans la gâchette.
2. Ensemble de coffres (1) selon la revendication 1, caractérisé en ce que ledit carrousel (2) comprend une pluralité des étages, qui peuvent être tous munis des ouvertures ayant des coffres égaux (3) ou ils peuvent être réalisés avec des secteurs différents de façon que le carrousel (2) puissent avoir des coffres des dimensions différentes, lesdites portes d'accès (8) étant prévues en nombre et dimensions correspondants aux étages et à le genre d'ouverture prévue dans chaque étage.
3. Ensemble de coffres (1) selon une des revendications précédentes, caractérisé en ce que lesdits secteurs avec des ouvertures contenant des coffres (3) contiennent des coffres fixes (3).
4. Ensemble de coffres (1) selon une des revendications 1 ou 2, caractérisé en ce que lesdits secteurs avec des ouvertures contenant des coffres (3) ont des coffres amovibles (3) qui peuvent être introduits dans les ouvertures.
5. Ensemble de coffres (1) selon une quelconque des revendications précédentes, caractérisé en ce que les dites coffres (3) sont munis d'une serrure de sécurité du type de barres à expansion.
6. Ensemble de coffres (1) selon une quelconque des revendications précédentes, caractérisé en ce que ladite fausse ouverture (4) de chaque étage est fermée par une plaque d'acier.
7. Ensemble de coffres (1) selon une quelconque des revendications précédentes, caractérisé en ce que ladite structure blindée comprend un châssis d'acier (17) avec des plaques intérieurement boulonnées et avec une porte blindée pour l'accès au carrousel pour l'entretien du même, les moyens de déplacement (11, 12, 13, 14, 15, 16) du carrousel étant placés au-dessus de la structure blindée.
8. Ensemble de coffres (1) selon une quelconque des revendications précédentes, caractérisé en ce que chacune des dites portes (8) est actionnée par un motoreducteur (19) avec lesdits moyens à computer, munis des moyens de sécurité pour bloquer la fermeture de la porte (8) en cas de besoin.
9. Ensemble de coffres (1) selon une quelconque des revendications précédentes, caractérisé en ce que lesdits moyens de sécurité consistent d'un joint à ressort et détente (20).
10. Ensemble de coffres (1) selon la revendication 1, caractérisé en ce que en correspondance de chacune des dites portes (8) ils sont prévus autres moyens de sécurité, en particulier une cellule photo-électrique.
11. Ensemble de coffres (1) selon une quelconque des revendications précédentes, caractérisé en ce que la gâchette, jointe directement aux moyens à computer, comprend un clavier (9) et/ou un lecteur de carte magnétique et/ou un display.
12. Ensemble de coffres (1) selon une quelconque des revendications précédentes, caractérisé en ce que lesdits moyens de déplacement du carrousel consistent d'un motoreducteur (11) joint avec l'axe de rotation (12) du carrousel (2) par un engrenage et

un système à chaîne et d'un décodeur électromécanique (14), d'une carte de contrôle logique et des cartes de contrôle du système de sécurité (16).

13. , Ensemble de coffres (1) selon une quelconque des revendications précédentes, caractérisé en ce que l'accès au coffre de l'utilisateur est subordonné à l'introduction des trois codes, un de lesquels étant introduit directement par l'utilisateur, l'ensemble étant agencé de façon que à la fin de chaque opération la fausse ouverture blindé est portée en correspondance de la porte respective.

5

10

15

20

25

30

35

40

45

50

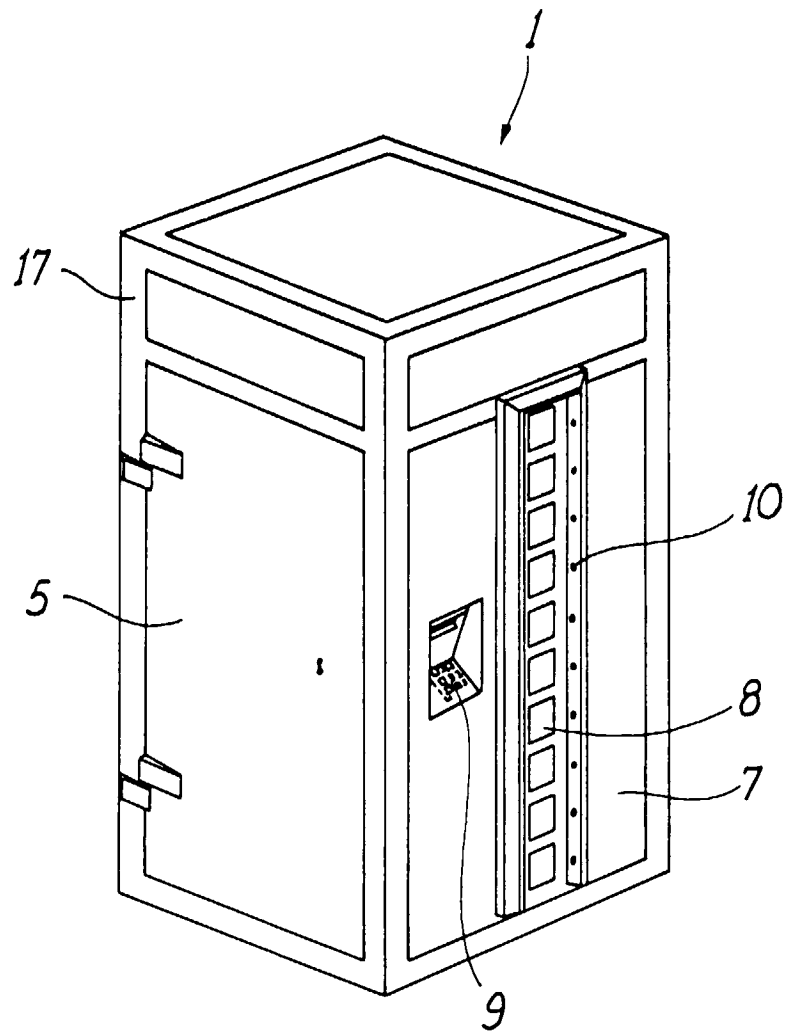

FIG. 1

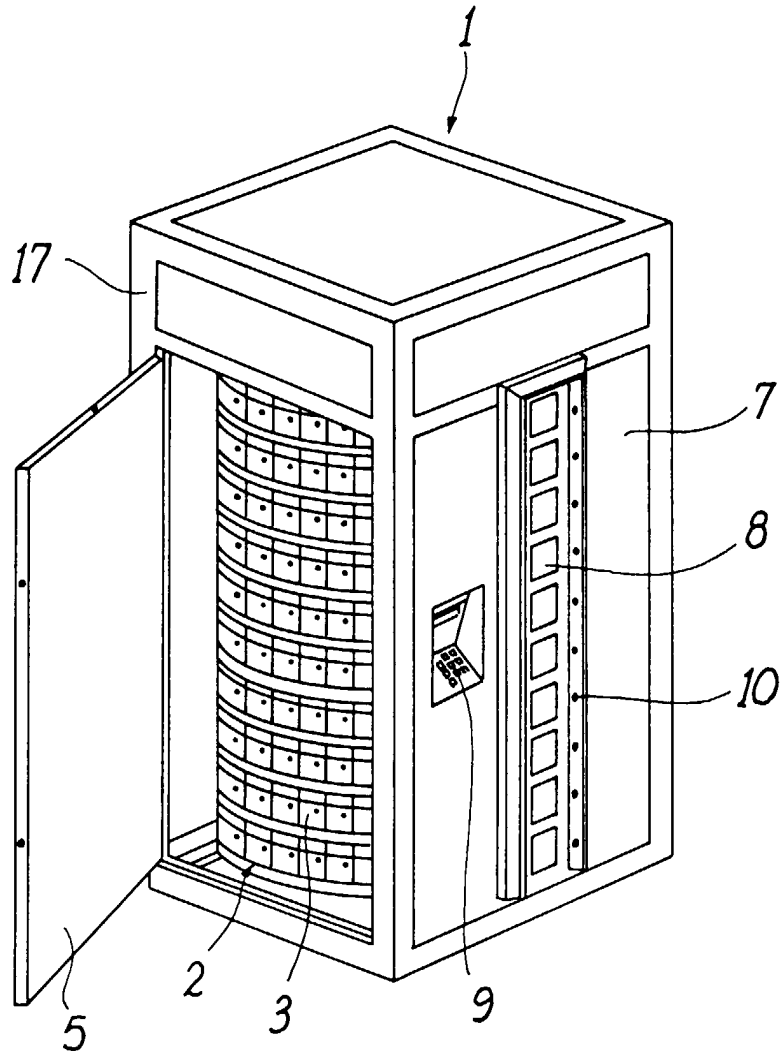

FIG. 2

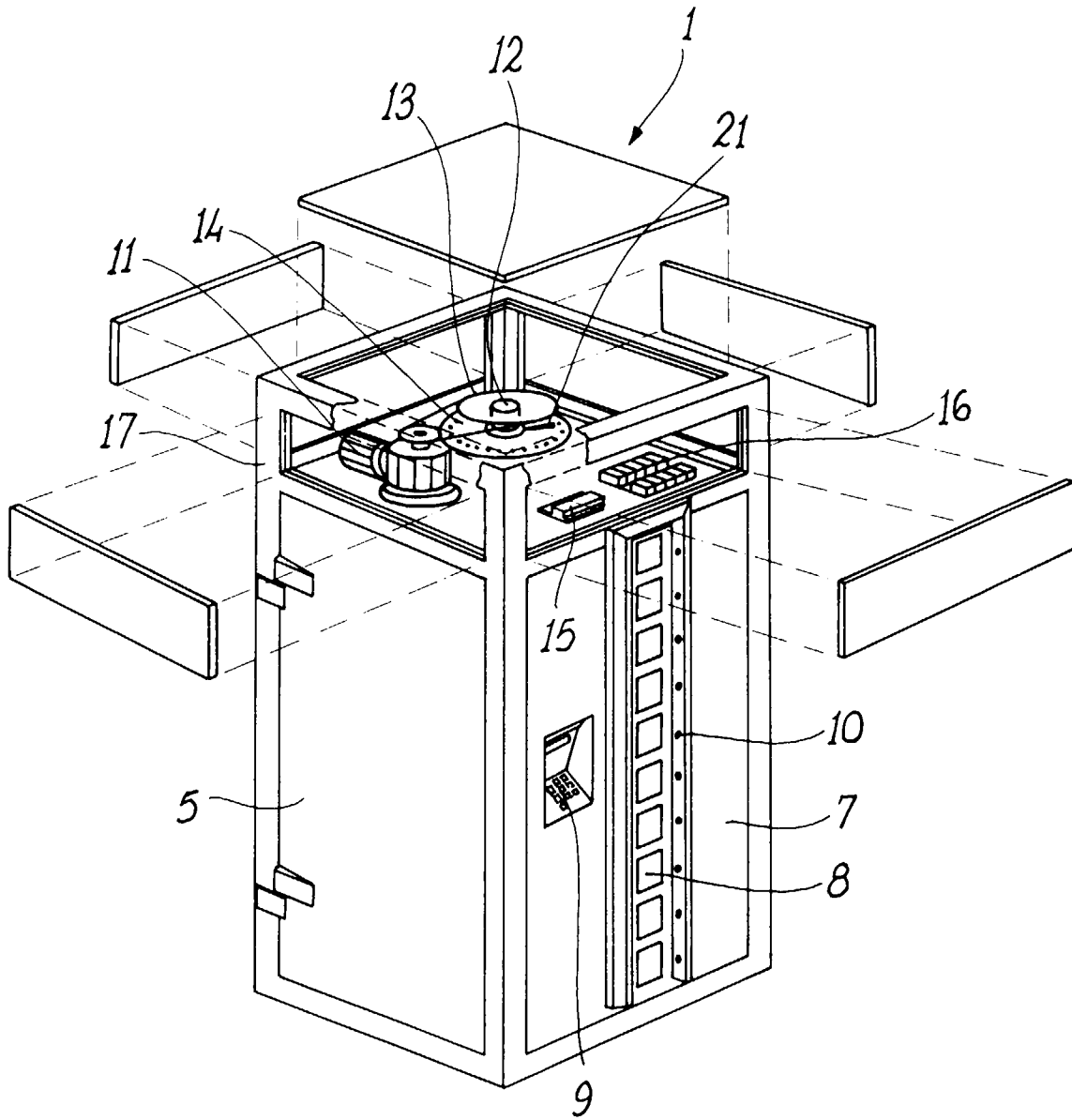

FIG. 3

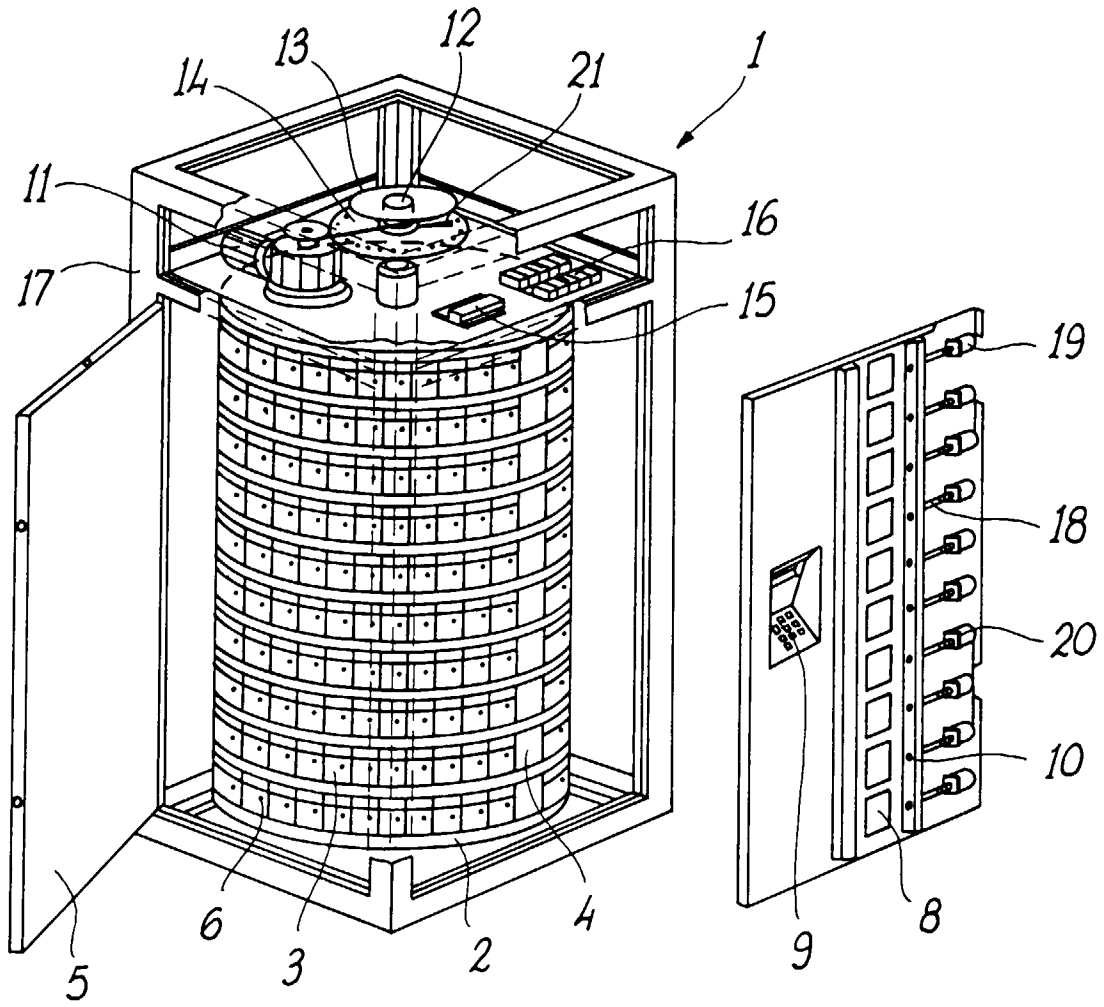

FIG. 4