

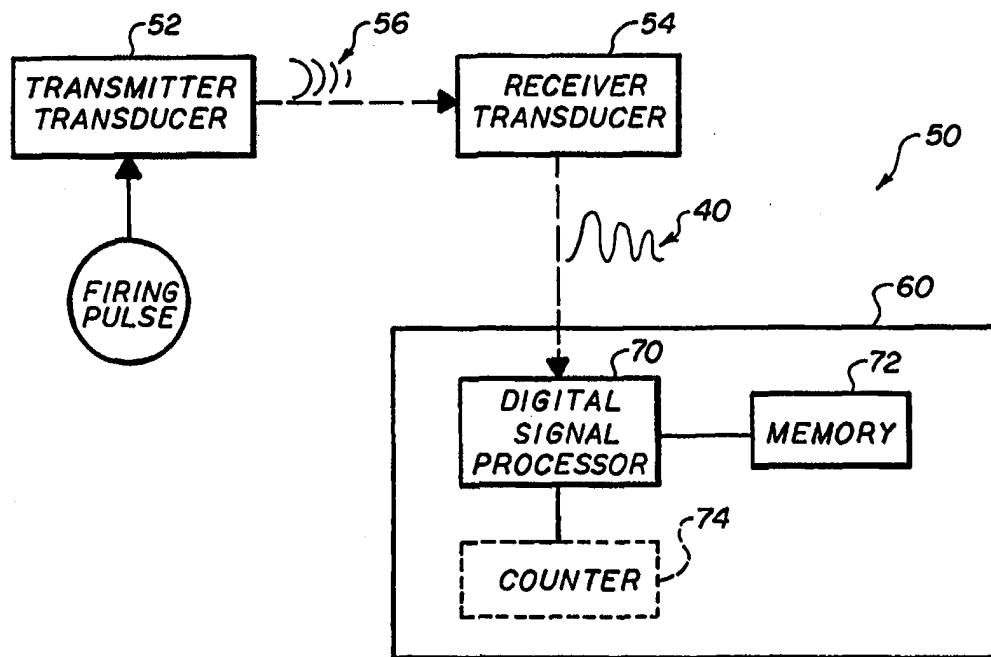

INTERNATIONAL APPLICATION PUBLISHED UNDER THE PATENT COOPERATION TREATY (PCT)

<p>(51) International Patent Classification ⁶ : A61B 8/00</p>	<p>A1</p>	<p>(11) International Publication Number: WO 98/46140 (43) International Publication Date: 22 October 1998 (22.10.98)</p>
<p>(21) International Application Number: PCT/US98/07548 (22) International Filing Date: 16 April 1998 (16.04.98) (30) Priority Data: 08/842,807 17 April 1997 (17.04.97) US (71) Applicant (for all designated States except US): SONOMETRICS CORPORATION [CA/CA]; 4500 Blakie Road, London, Ontario (CA). (72) Inventors; and (75) Inventors/Applicants (for US only): VESELY, Ivan [CA/US]; 1216 Oakridge Drive, Cleveland Heights, OH 44121 (US). SMITH, Wayne, L. [CA/CA]; Unit 27043, 60 North Centre Road, London, Ontario (CA). (74) Agent: JAFFE, Michael; Benesch, Friedlander, Coplan & Aronoff LLP, 2300 BP Tower, 200 Public Square, Cleveland, OH 44114 (US).</p>		<p>(81) Designated States: AL, AM, AT, AT (Utility model), AU (Petty patent), AZ, BA, BB, BG, BR, BY, CA, CH, CN, CU, CZ, CZ (Utility model), DE, DE (Utility model), DK, DK (Utility model), EE, EE (Utility model), ES, FI, FI (Utility model), GB, GE, GH, GM, HU, ID, IL, IS, JP, KE, KG, KP, KR, KZ, LC, LK, LR, LS, LT, LU, LV, MD, MG, MK, MN, MW, MX, NO, NZ, PL, PT, RO, RU, SD, SE, SG, SI, SK, SK (Utility model), SL, TJ, TM, TR, TT, UA, UG, US, UZ, VN, YU, ZW, ARIPO patent (GH, GM, KE, LS, MW, SD, SZ, UG, ZW), Eurasian patent (AM, AZ, BY, KG, KZ, MD, RU, TJ, TM), European patent (AT, BE, CH, CY, DE, DK, ES, FI, FR, GB, GR, IE, IT, LU, MC, NL, PT, SE), OAPI patent (BF, BJ, CF, CG, CI, CM, GA, GN, ML, MR, NE, SN, TD, TG).</p> <p>Published With international search report.</p>

(54) Title: ULTRASOUND-BASED 3-D TRACKING SYSTEM USING A DIGITAL SIGNAL PROCESSOR



(57) Abstract

This invention is a system (50) for determining a time delay of a signal (56) propagating through a medium. The time delay is used to determine the distance between transducers (52, 54) arranged within a body. One or more Digital Signal Processors (DSP) (70) are programmed to recognize various waveform patterns by matching a received waveform to a template waveform.

FOR THE PURPOSES OF INFORMATION ONLY

Codes used to identify States party to the PCT on the front pages of pamphlets publishing international applications under the PCT.

AL	Albania	ES	Spain	LS	Lesotho	SI	Slovenia
AM	Armenia	FI	Finland	LT	Lithuania	SK	Slovakia
AT	Austria	FR	France	LU	Luxembourg	SN	Senegal
AU	Australia	GA	Gabon	LV	Latvia	SZ	Swaziland
AZ	Azerbaijan	GB	United Kingdom	MC	Monaco	TD	Chad
BA	Bosnia and Herzegovina	GE	Georgia	MD	Republic of Moldova	TG	Togo
BB	Barbados	GH	Ghana	MG	Madagascar	TJ	Tajikistan
BE	Belgium	GN	Guinea	MK	The former Yugoslav Republic of Macedonia	TM	Turkmenistan
BF	Burkina Faso	GR	Greece	ML	Mali	TR	Turkey
BG	Bulgaria	HU	Hungary	MN	Mongolia	TT	Trinidad and Tobago
BJ	Benin	IE	Ireland	MR	Mauritania	UA	Ukraine
BR	Brazil	IL	Israel	MW	Malawi	UG	Uganda
BY	Belarus	IS	Iceland	MX	Mexico	US	United States of America
CA	Canada	IT	Italy	NE	Niger	UZ	Uzbekistan
CF	Central African Republic	JP	Japan	NL	Netherlands	VN	Viet Nam
CG	Congo	KE	Kenya	NO	Norway	YU	Yugoslavia
CH	Switzerland	KG	Kyrgyzstan	NZ	New Zealand	ZW	Zimbabwe
CI	Côte d'Ivoire	KP	Democratic People's Republic of Korea	PL	Poland		
CM	Cameroon	KR	Republic of Korea	PT	Portugal		
CN	China	KZ	Kazakstan	RO	Romania		
CU	Cuba	LC	Saint Lucia	RU	Russian Federation		
CZ	Czech Republic	LI	Liechtenstein	SD	Sudan		
DE	Germany	LK	Sri Lanka	SE	Sweden		
DK	Denmark	LR	Liberia	SG	Singapore		
EE	Estonia						

ULTRASOUND-BASED 3-D TRACKING SYSTEM USING A DIGITAL SIGNAL PROCESSOR

Related Applications

The present application is a continuation-in-part (CIP) of co-pending PCT International Application No. PCT/CA96/00194, which is a continuation-in-part of U.S. Application Serial No. 08/411,959, filed March 28, 1995, now U.S. Patent No. 5,515,853. The contents of both applications are incorporated herein by reference.

Field of Invention

The present invention relates generally to an ultrasound based 3-D tracking system, and more particularly to an ultrasound based 3-D tracking system using a digital signal processor to determine travel time for ultrasonic sound waves to isolate relative positions of objects.

Background of the Invention

Using the time-of-flight principle of high frequency sound waves, it is possible to accurately measure distances within an aqueous medium, such as inside the body of a living being during a surgical procedure. High frequency sound, or ultrasound, is defined as vibrational energy that ranges in frequency from 100 kHz to 10 MHz. The device used to obtain three-dimensional measurements using sound waves is known as a sonomicrometer. Typically, a sonomicrometer consists of a pair

- 2 -

of piezoelectric transducers (i.e., one transducer acts as a transmitter while the other transducer acts as a receiver). The transducers are implanted into a medium, and connected to electronic circuitry. To measure the distance between the transducers, the transmitter is electrically energized to produce ultrasound. The resulting sound wave then propagates through the medium until it is detected by the receiver.

The transmitter typically takes the form of a piezoelectric crystal that is energized by a high voltage spike, or impulse function lasting under a microsecond. This causes the piezoelectric crystal to oscillate at its own characteristic resonant frequency. The envelope of the transmitter signal decays rapidly with time, usually producing a train of six or more cycles that propagate away from the transmitter through the aqueous medium. The sound energy also attenuates with every interface that it encounters.

The receiver also typically takes the form of a piezoelectric crystal (with similar characteristics to the transmitter piezoelectric crystal), that detects the sound energy produced by the transmitter and begins to vibrate in response thereto. This vibration produces an electronic signal in the order of millivolts, that can be amplified by appropriate receiver circuitry.

The propagation velocity of ultrasound in an aqueous medium is well documented. The distance traveled by a pulse of ultrasound can therefore be measured simply by recording the time delay between the instant the sound is transmitted and when it is received.

- 3 -

In the prior art, counters and threshold detect circuitry have been used to determine the travel time of the waveforms transmitted between the transducers. A counter is associated with each transducer and waveforms are used as a trigger for the counter. Threshold detect circuitry stops the counter when a rising voltage crosses
5 above the noise level. Using counters and threshold detect circuitry for determining travel time limits precision to the counter frequency and requires a significant number of components.

The present invention provides a unique and advantageous system using a digital signal processor (DSP) to determine a propagation delay time for the
10 purpose of tracking the position of a device moving through a medium.

Summary of the Invention

According to the present invention there is provided a digital signal processor (DSP) for matching a received waveform to a template waveform and determining a waveform travel time.

15 An advantage of the present invention is the provision of a digital signal processor (DSP), which eliminates the need for counters and associated waveform triggering circuitry.

Another advantage of the present invention is the provision of a DSP which can sample and digitize analog signals at a very high rate.

20 Another advantage of the present invention is the provision of a DSP programmed to recognize various waveform patterns.

- 4 -

Still other advantages of the invention will become apparent to those skilled in the art upon a reading and understanding of the following detailed description, accompanying drawings and appended claims.

Brief Description of the Drawings

5 The invention may take physical form in certain parts and arrangements of parts, a preferred embodiment and method of which will be described in detail in this specification and illustrated in the accompanying drawings which form a part hereof, and wherein:

Fig. 1 is a diagram of a template waveform;

10 Fig. 2 is a diagram of an output signal waveform;

Fig. 3 is a diagram of an output signal waveform superimposed over a template waveform;

Fig. 4 is a timing diagram for a first embodiment of the present invention;

15 Fig. 5 is a timing diagram for a second embodiment of the present invention; and

Fig. 6 is a block diagram of a system according to the present invention.

- 5 -

Detailed Description of the Preferred Embodiment

Referring now to the drawings wherein the showings are for the purposes of illustrating a preferred embodiment of the invention only and not for purposes of limiting same, Fig. 1 shows a template waveform 20 having a start point 22 and a peak point 24. Template waveform 20 is characteristic of a typical electronic signal generated by an piezoelectric transducer crystal when activated in response to a sound wave. As indicated above, a piezoelectric transducer will vibrate in response to receipt of a sound wave. The vibration in turn produces an electronic signal (i.e., "output signal waveform"). Fig. 2 shows a characteristic output signal waveform 40 generated by an actual piezoelectric transducer crystal, when activated by an ultrasonic sound wave. Output signal waveform 40 has a start point 42 and a peak point 44. A digital signal processor (DSP) is programmed to compare output signal waveform 40 to template waveform 20 stored in memory.

When an output signal waveform 40 is received by the DSP, it is suitably digitized at a high sampling rate. A higher sampling rate provides a more accurate digital representation of the wave, and minimizes the chance of a loss of short duration transients. Thereafter, output signal waveform 40 (in digital form) is convolved with template waveform 20. The convolution or autocorrelation process will produce a maximum at a point where these two signals have the best match, as seen in Fig. 3. It should be appreciated that an autocorrelation function provides a measure of the similarity between delayed and undelayed versions of a signal, expressed as a delay function.

- 6 -

By matching a point (e.g., peak point 44) on output signal waveform 40 with the corresponding point (e.g., peak point 24) on template waveform 20, start point 42 of output signal waveform 40 can be determined. In this respect, start point 42 is matched with start point 22. By matching start point 42 of output signal waveform 40 with start point 22 of template waveform 20, the time delay (t_{delay}) between the energizing (i.e., "firing") of a transmitter transducer and the generation of output signal waveform 40 by a receiver transducer can be determined. Accordingly, the distance between a pair of transducers can be computed.

In the embodiment illustrated by the timing diagram shown in Fig. 4, the DSP begins sampling and digitizing data at the moment the transmitter transducer is "fired" (t_{fire}). It should be noted that "firing" refers to energization of a transducer by a voltage spike or impulse function, causing the piezoelectric crystal to oscillate at its own characteristic resonant frequency. The DSP will sample and digitize noise (from the receiver transducer) until output signal waveform 40 is received at t_0 . Each item of digitized data is stored at an individual memory location in a memory array. Accordingly, if the incoming data is sampled at a rate of 1 MHZ, then digitized data will be stored every 1 microsecond (sampling period). Therefore, each consecutive memory location in the array represents 1 microsecond of elapsed time. It then follows that the product of: (1) the position in the memory array corresponding to t_0 and (2) the sampling period (t_{sample}), will provide a measure of the time delay (t_{delay}). As indicated above, the position of t_0 in the memory array is determined by convolving output signal waveform 40 with template waveform 20. Once the time

- 7 -

delay (t_{delay}) is determined, the distance between a given pair of transducers can be computed.

As can be seen from Fig. 4, the time delay (t_{delay}) is represented by the distance between start point 42 and start point 22. Likewise, the time delay (t_{delay}) is also represented by the distance between peak position 44 and peak position 24.

It should be noted that in most cases a DSP would be required for each receiver transducer in this embodiment, unless all of the received channels are multiplexed together and passed onto one or more DSPs. The foregoing procedure replaces the need for counters (which act as timers) and threshold detect circuitry for triggering the counters.

An alternative embodiment of the present invention will now be described with reference to Fig. 5. In this embodiment, the DSP will wait for a predetermined period of time (t_{wait}) before beginning to sample and digitize the incoming signal. The value of t_{wait} is determined such that the DSP begins sampling and digitizing the incoming signal just before the DSP is expected to receive output signal waveform 40. A counter (acting as a timer) is used to determine the value of t_{wait} . The counter is started at the moment the transmitter transducer is "fired." When a predetermined period of time has elapsed, the counter is stopped. The value of the counter is indicative of the value of t_{wait} . Just as in the case of the first embodiment described above, the DSP will sample and digitize noise until output signal waveform 40 is received. The period of time during which noise is sampled and digitized is referred to as t_{noise} . As can be seen from Fig. 5, the sum of t_{wait} and t_{noise} is equal to

- 8 -

t_{delay} . The value of t_{noise} is determined in the same manner as the value of t_{delay} is determined in the first embodiment described above. The value of t_{noise} is added to the value of t_{wait} to compute t_{delay} . It should be appreciated that t_{wait} can be adjusted if necessary to avoid missing any portion of output signal waveform 40, or to avoid digitizing to much noise prior to receipt of output signal waveform 40.

It should be noted that while the first embodiment eliminates the need for a threshold detect circuit (which stops a timing device when the rising voltage crosses a threshold above the noise level) and a timing device (such as a counter), it also places great demands on the DSP and requires sufficient memory to store large quantities of digitized sampling data. In contrast, the second embodiment only eliminates the need for a threshold detect circuit. However, the demand on the DSP is less, and less memory is needed since fewer data points are recorded.

Turning now to Fig. 6, there is shown a block diagram of a system 50 according to the present invention. System 50 is generally comprised of a transmitter transducer 52, a receiver transducer 54 and a 3-D tracking system 60. 3-D tracking system 60 includes a digital signal processor (DSP) 70, a memory 72 and a counter 74 (in the case of the second embodiment described above). Memory 72 stores template waveform 20, as well as the digitized samples of output signal waveform 40. It should be appreciated that 3-D tracking system 60 includes additional component which are described in detail in U.S. Patent No. 5,515,853 and PCT Application No. WO96/31753.

- 9 -

As indicated above, transmitter transducer 52 is fired by a firing pulse. In response thereto, a sound wave 56 is generated and received by receiver transducer 54. Receiver transducer 54 responds to sound wave 56 by generating output signal waveform 40, which is received by DSP 70. DSP 70 uses the template waveform stored in memory 72 to determine a propagation time delay, and thus compute the distance between transmitter transducer 52 and receiver transducer 54.

Yet another embodiment of the subject invention suitably employs application of a suitable curve filtering algorithm to captured intervals. Reducing data to equations is suitably accomplished by any number of readily available algorithms or systems. A direct, mathematical analysis and comparison between such equations would therefore allow for matching of the waveforms.

The invention has been described with reference to a preferred embodiment. Obviously, modifications and alterations will occur to others upon a reading and understanding of this specification. It is intended that all such modifications and alterations be included insofar as they come within the scope of the appended claims or the equivalents thereof.

- 10 -

Having thus described the invention, it is now claimed:

1. A system for determining a propagation time delay of a transmit waveform initiated by an associated transmitter means and received by an associated receiver means, wherein said receiver means generates an output in the form of an output waveform in response to receipt of the transmit waveform, the system comprising:

template storage means for storing template waveform data representative of a characteristic output waveform;

sampling means for sampling the output of the receiver means at a predetermined sampling rate and converting the output waveform to digital output waveform data;

comparison means for comparing the digital output waveform data to the template waveform data to determine the digital output waveform data corresponding to the beginning of the output waveform; and

computation means for computing the propagation time delay in accordance with the digital output waveform data corresponding to the beginning of the output waveform.

2. A system according to claim 1, wherein said comparison means includes a convolving means for convolving said digital output waveform data and said template waveform data.

- 11 -

3. A system according to claim 1, wherein said comparison means includes an autocorrelation means for correlating said digital output waveform data with said template waveform data.

4. A system according to claim 1, wherein said transmitter means and receiver means are piezoelectric transducer means.

5. A system according to claim 4, wherein said characteristic output waveform is characteristic of piezoelectric crystal oscillations.

6. A system according to claim 1, wherein said sampling means stores the digital output waveform data in a memory array having a respective position for each item of digital output waveform data, and said computation means includes means for computing the product of (1) the position in the memory array of the digital output waveform data corresponding to the beginning of the output
5 waveform and (2) the predetermined sampling rate, wherein said product is indicative of the propagation time delay.

7. A system according to claim 1, wherein said system further comprises a timer means for determining a waiting time beginning with initiation of the transmit waveform and ending before generation of the output waveform.

- 12 -

8. A system according to claim 7, wherein said sampling means stores the digital output waveform data in a memory array having a respective position for each item of digital output waveform data, and said computation means includes means for computing the product of (1) the position in the memory array of the digital output waveform data corresponding to the beginning of the output waveform and (2) the predetermined sampling rate, and means for summing the product with said waiting time, wherein the sum is indicative of the propagation time delay.

9. A system according to claim 8, wherein said timer means includes a counter means.

10. A method for determining a propagation time delay of a transmit waveform initiated by an associated transmitter means and received by an associated receiver means, wherein said receiver means generates an output in the form of an output waveform in response to receipt of the transmit waveform, the method comprising:

obtaining template waveform data representative of a characteristic output waveform;

sampling the output of the receiver means at a predetermined sampling rate and converting the output waveform to digital output waveform data;

- 13 -

10

comparing the digital output waveform data to the template waveform data to determine the digital output waveform data corresponding to the beginning of the output waveform; and

computing the time delay in accordance with the digital output waveform data corresponding to the beginning of the output waveform.

11. A method according to claim 10, wherein said step of comparing includes the step of convolving said digital output waveform data and said template waveform data.

12. A method according to claim 10, wherein said comparing step includes the step of correlating said digital output waveform data with said template waveform data.

13. A method according to claim 10, wherein said transmitter means and receiver means are piezoelectric transducer means.

14. A method according to claim 13, wherein said characteristic output waveform is characteristic of piezoelectric crystal oscillations.

15. A method according to claim 10, wherein said step of sampling includes the step of storing the digital output waveform data in a memory array

- 14 -

5 having a respective position for each item of digital output waveform data, and said step of computing includes the step of computing the product of (1) the position in the memory array of the digital output waveform data corresponding to the beginning of the output waveform and (2) the predetermined sampling rate, wherein said product is indicative of the propagation time delay.

16. A method according to claim 10, wherein said method further comprises the step of determining a waiting time beginning with initiation of the transmit waveform and ending before generation of the output waveform.

17. A method according to claim 16, wherein said step of sampling includes the step of storing the digital output waveform data in a memory array having a respective position for each item of digital output waveform data, and said step of computing includes the steps of:

5 (a) computing the product of (1) the position in the memory array of the digital output waveform data corresponding to the beginning of the output waveform and (2) the predetermined sampling rate, and

(b) summing the product with said waiting time, wherein the sum is indicative of the propagation time delay.

18. A method for determining a time delay of a signal propagating through a medium comprising:

- 15 -

initiating a transmit waveform from a first location;

generating an output waveform at a second location in response to receipt of

5

the transmit waveform;

storing template waveform data representative of a standard output waveform;

digitizing the output waveform into digital output waveform data; and

comparing the digital output waveform data to the template waveform data to

determine the time delay between initiation of the transmit waveform and generation

10

of the output waveform.

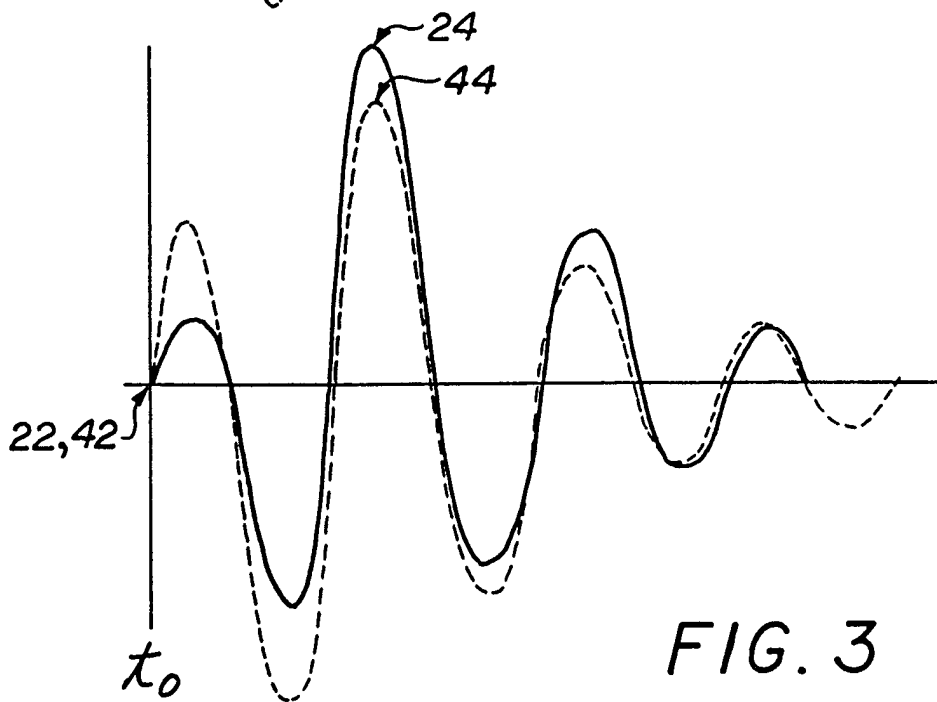
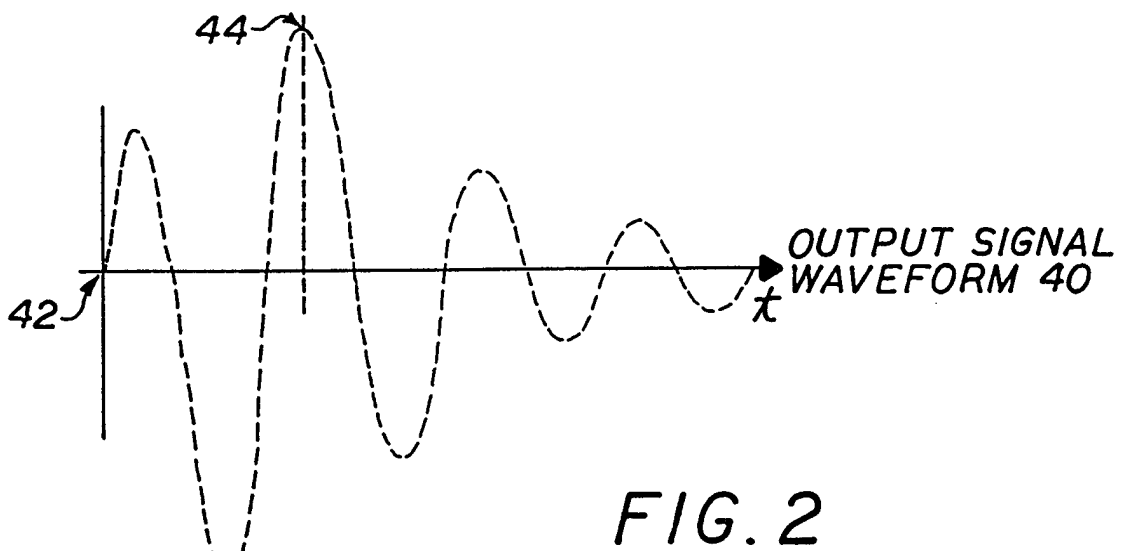
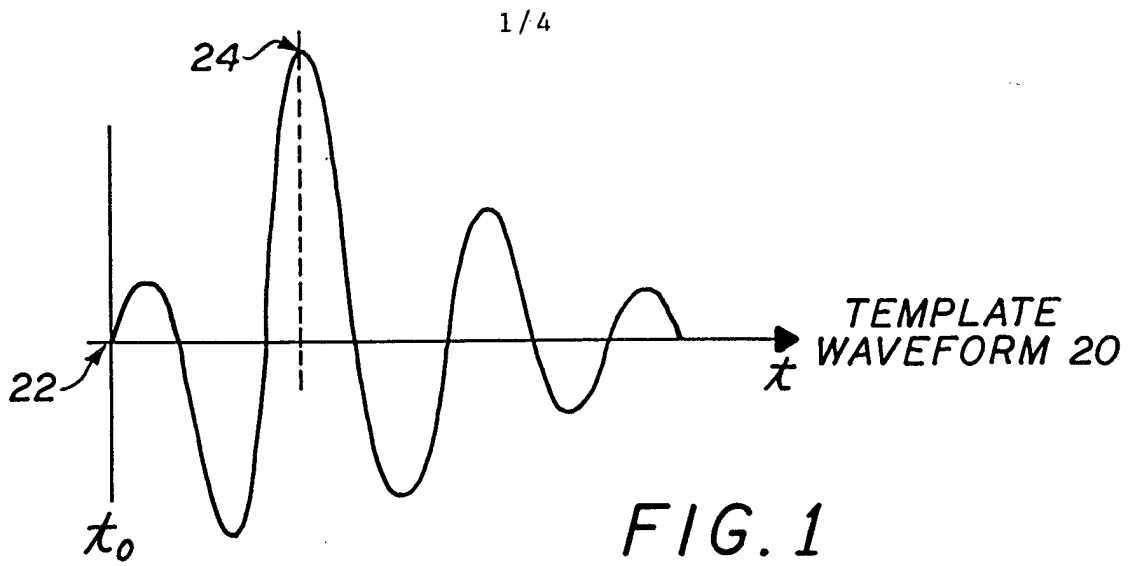

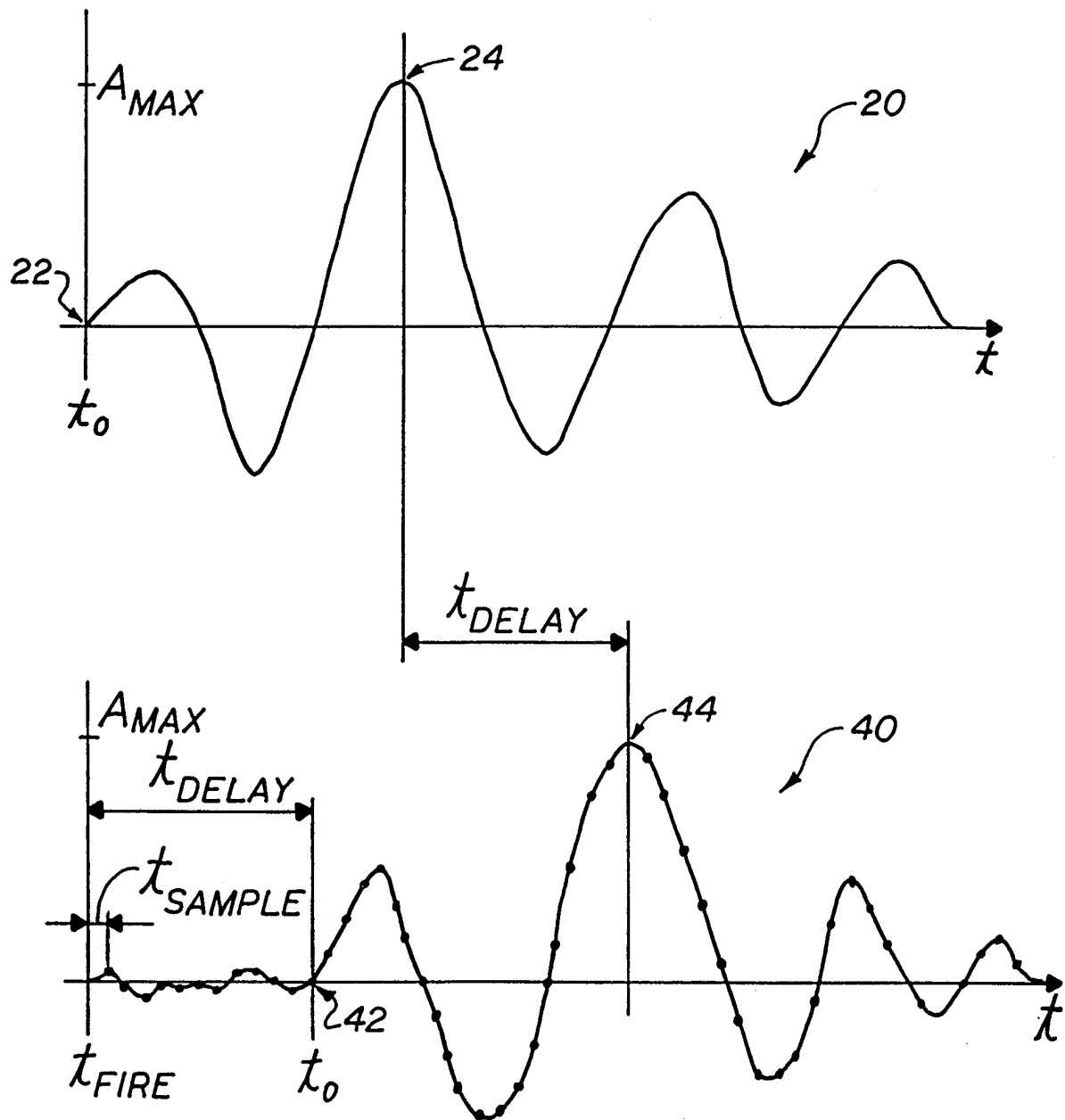

FIG. 4

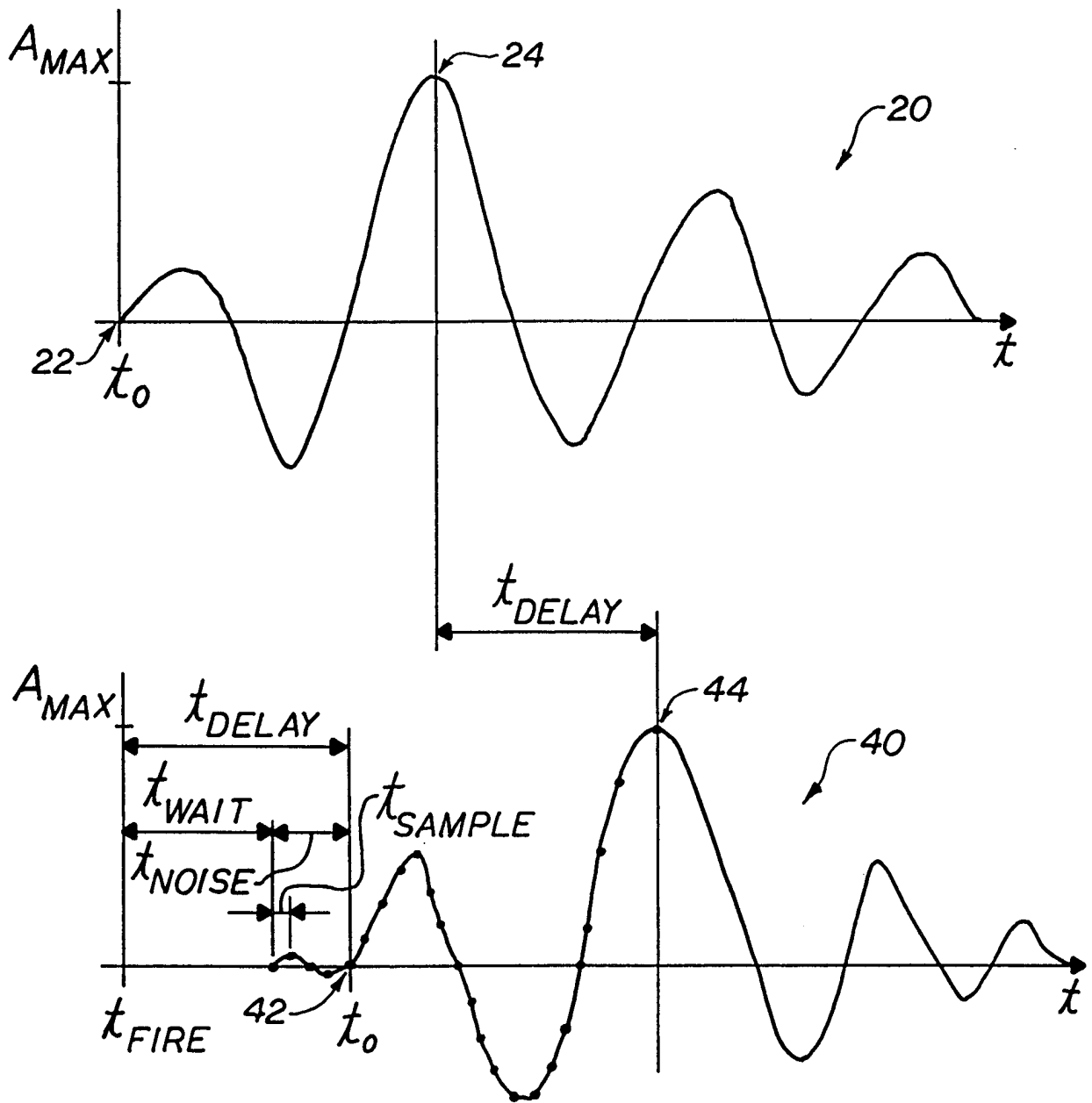

FIG. 5

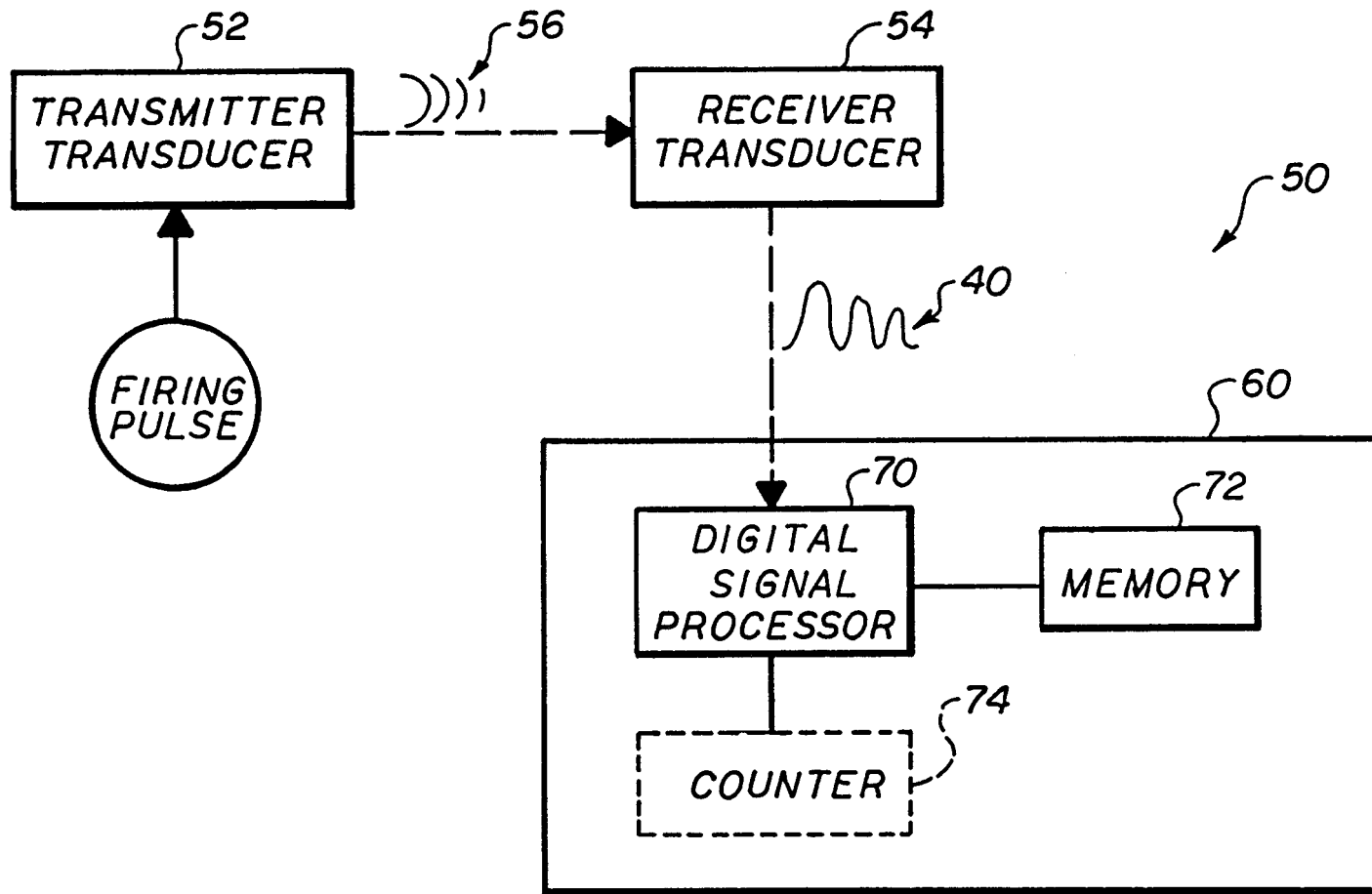

FIG. 6

INTERNATIONAL SEARCH REPORT

International application No.
PCT/US98/07548

A. CLASSIFICATION OF SUBJECT MATTER

IPC(6) :A61B 8/00
US CL :600/437

According to International Patent Classification (IPC) or to both national classification and IPC

B. FIELDS SEARCHED

Minimum documentation searched (classification system followed by classification symbols)

U.S. : 342/27; 364/724.1; 600/437, 438, 442, 509

Documentation searched other than minimum documentation to the extent that such documents are included in the fields searched

Electronic data base consulted during the international search (name of data base and, where practicable, search terms used)

C. DOCUMENTS CONSIDERED TO BE RELEVANT

Category*	Citation of document, with indication, where appropriate, of the relevant passages	Relevant to claim No.
A	US 5,438,531 A (SHANK) 01 August 1995, entire document.	1-18
A	US 3,398,183 A (ELLIOTT) 14 March 1995, entire document.	1-18
A	US 4,743,906 A (FULLERTON) 10 May 1988, entire document.	1-18

Further documents are listed in the continuation of Box C. See patent family annex.

* Special categories of cited documents:	*T* later document published after the international filing date or priority date and not in conflict with the application but cited to understand the principle or theory underlying the invention
A document defining the general state of the art which is not considered to be of particular relevance	*X* document of particular relevance; the claimed invention cannot be considered novel or cannot be considered to involve an inventive step when the document is taken alone
E earlier document published on or after the international filing date	*Y* document of particular relevance; the claimed invention cannot be considered to involve an inventive step when the document is combined with one or more other such documents, such combination being obvious to a person skilled in the art
L document which may throw doubts on priority claim(s) or which is cited to establish the publication date of another citation or other special reason (as specified)	*G* document member of the same patent family
O document referring to an oral disclosure, use, exhibition or other means	
P document published prior to the international filing date but later than the priority date claimed	

Date of the actual completion of the international search

19 MAY 1998

Date of mailing of the international search report

09 JUN 1998

Name and mailing address of the ISA/US
Commissioner of Patents and Trademarks
Box PCT
Washington, D.C. 20231

Facsimile No. (703) 305-3230

Authorized officer

GEORGE MANUEL

Telephone No. (703) 308-2118