



US 20050145285A1

(19) **United States**

(12) **Patent Application Publication**
Extrand

(10) **Pub. No.: US 2005/0145285 A1**

(43) **Pub. Date: Jul. 7, 2005**

(54) **FLUID HANDLING COMPONENT WITH
ULTRAPHOBIC SURFACES**

(52) **U.S. Cl. 138/39**

(75) **Inventor: Charles W. Extrand, Minneapolis, MN
(US)**

(57) **ABSTRACT**

Correspondence Address:
**PATTERSON, THUENTE, SKAAR &
CHRISTENSEN, P.A.
4800 IDS CENTER
80 SOUTH 8TH STREET
MINNEAPOLIS, MN 55402-2100 (US)**

A fluid handling component having a durable ultraphobic fluid contact surface that is capable of exhibiting ultraphobic properties at liquid pressures of one atmosphere and above. The surface generally includes a substrate portion with a multiplicity of projecting regularly shaped microscale or nanoscale asperities disposed so that the surface has a predetermined contact line density measured in meters of contact line per square meter of surface area equal to or greater than a contact line density value " Λ_L " determined according to the formula:

(73) **Assignee: Entegris, Inc**

(21) **Appl. No.: 10/977,512**

(22) **Filed: Oct. 29, 2004**

Related U.S. Application Data

(63) **Continuation of application No. 10/454,742, filed on
Jun. 3, 2003, now Pat. No. 6,845,788.**

$$\Lambda_L = \frac{-10,330}{\gamma \cos(\theta_{a,0} + \omega - 90^\circ)}$$

(60) **Provisional application No. 60/462,963, filed on Apr.
15, 2003.**

Publication Classification

(51) **Int. Cl.⁷ F15D 1/00**

where γ is the surface tension of the liquid in Newtons per meter, $\theta_{a,0}$ is the experimentally measured true advancing contact angle of the liquid on the asperity material in degrees, and ω is the asperity rise angle in degrees.

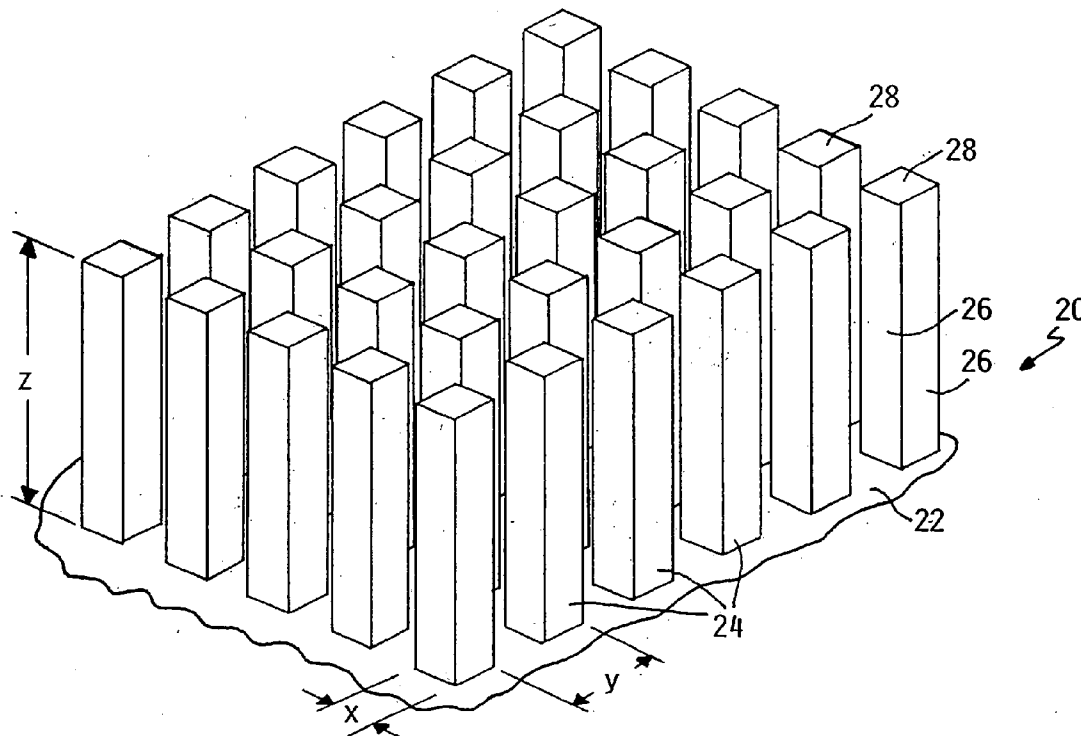

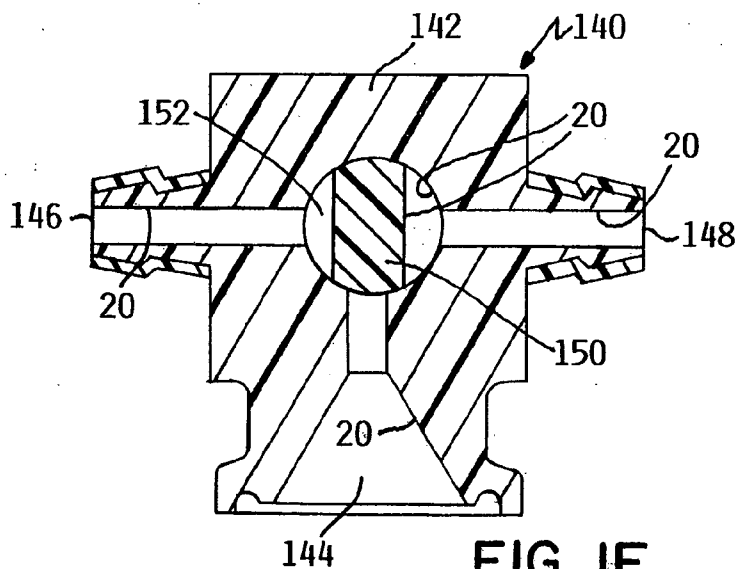
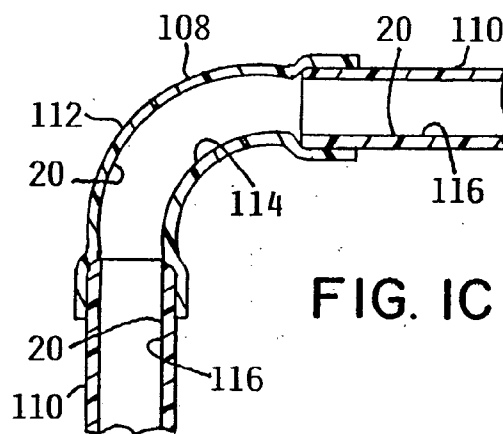
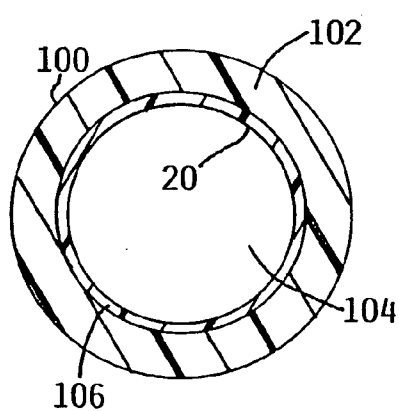
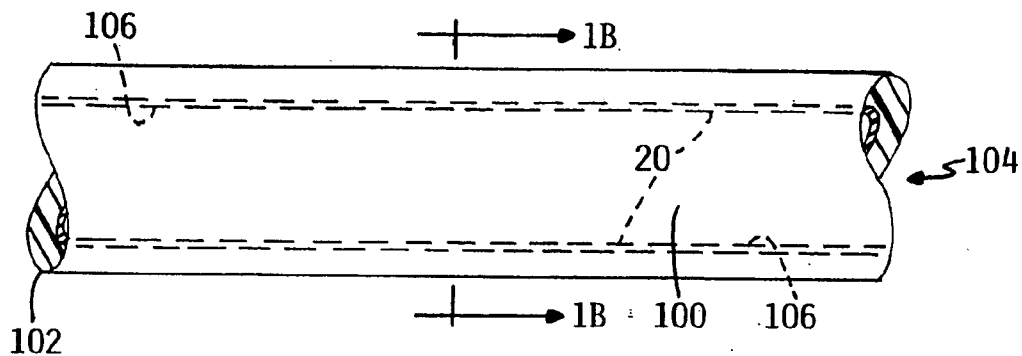

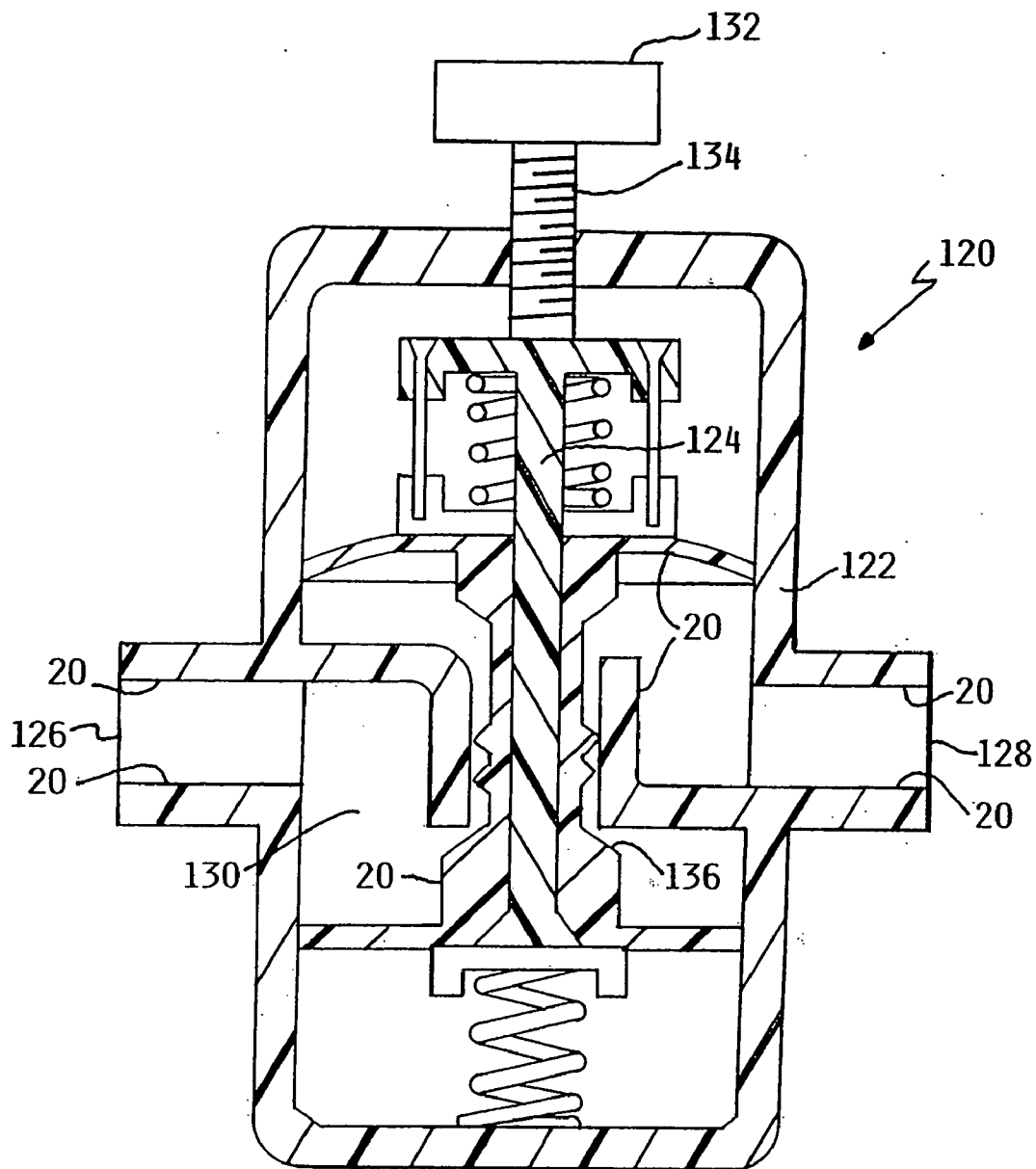

FIG. 1D

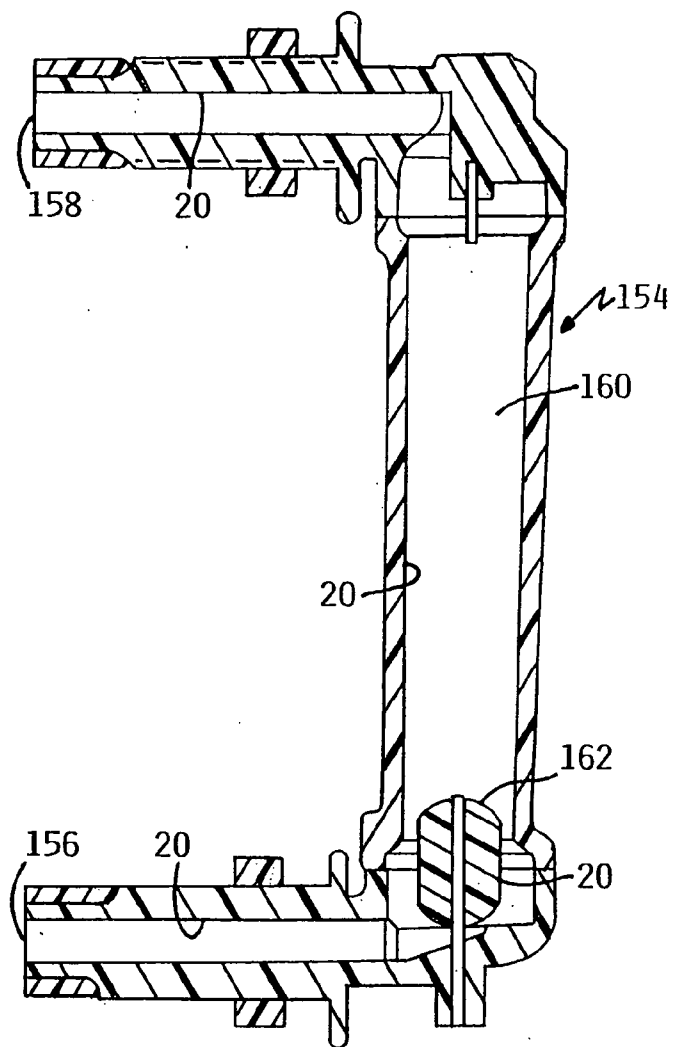

FIG. 1F

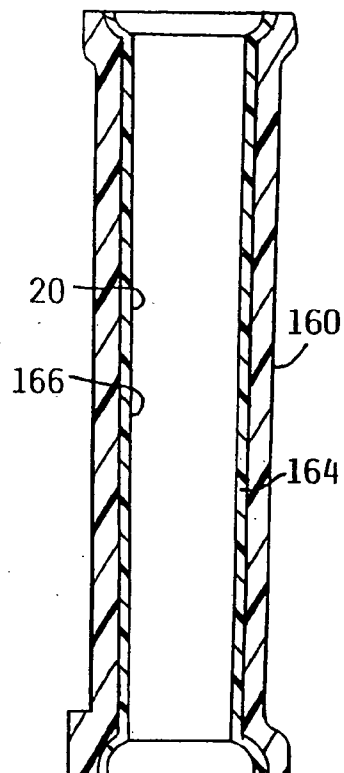

FIG. 1G

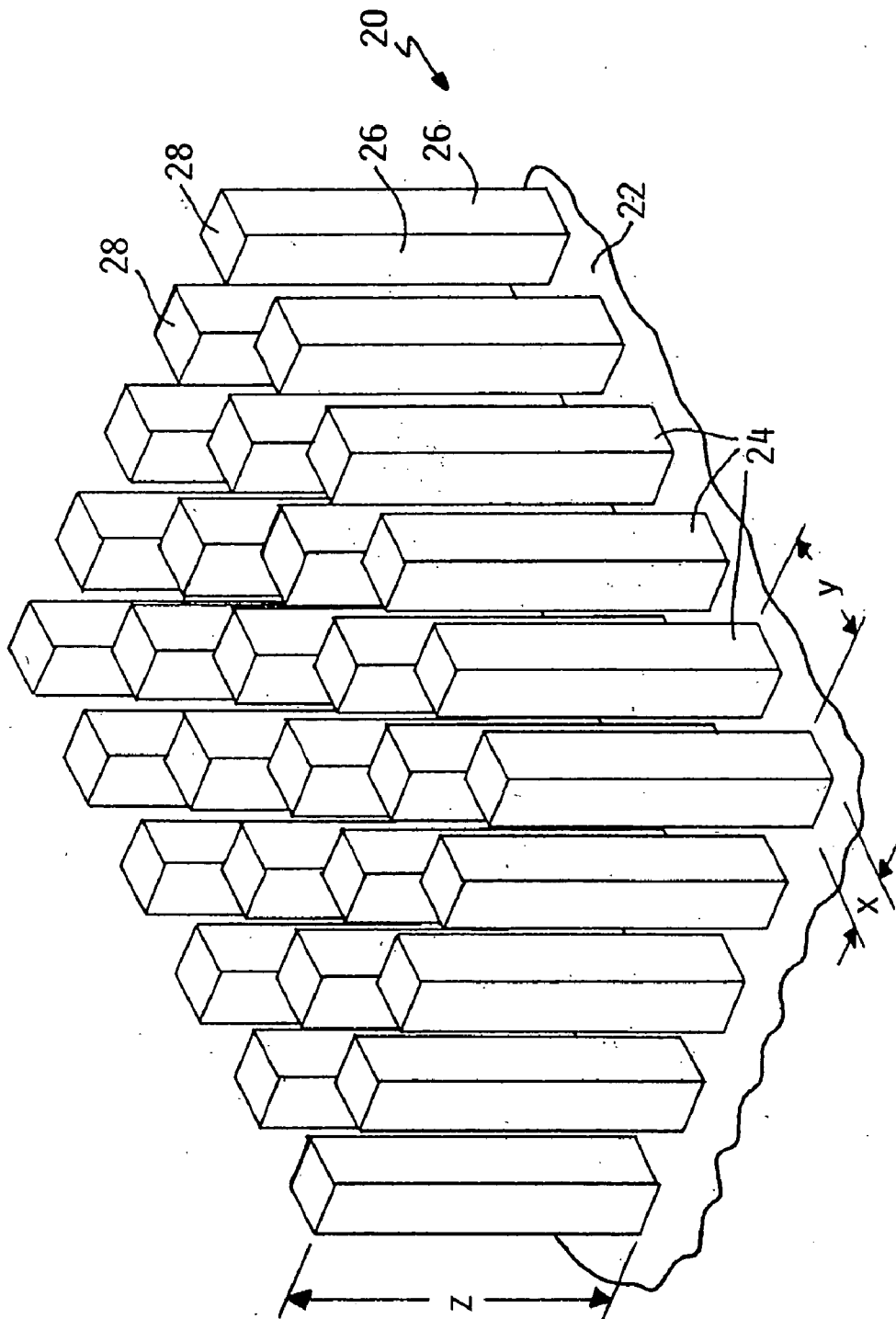

FIG. 1H

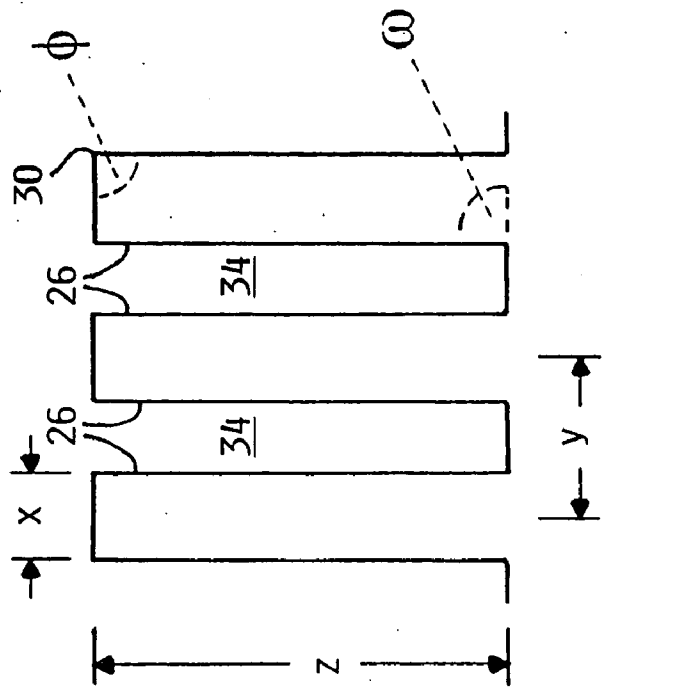

FIG. 2

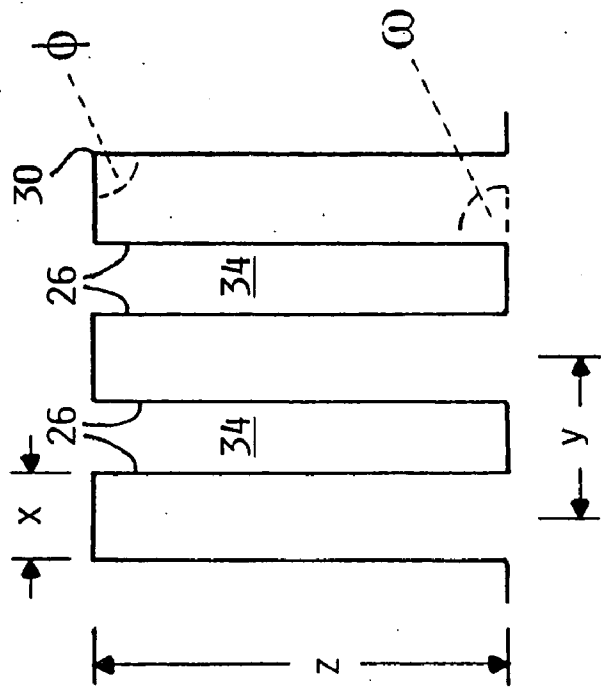

FIG. 3

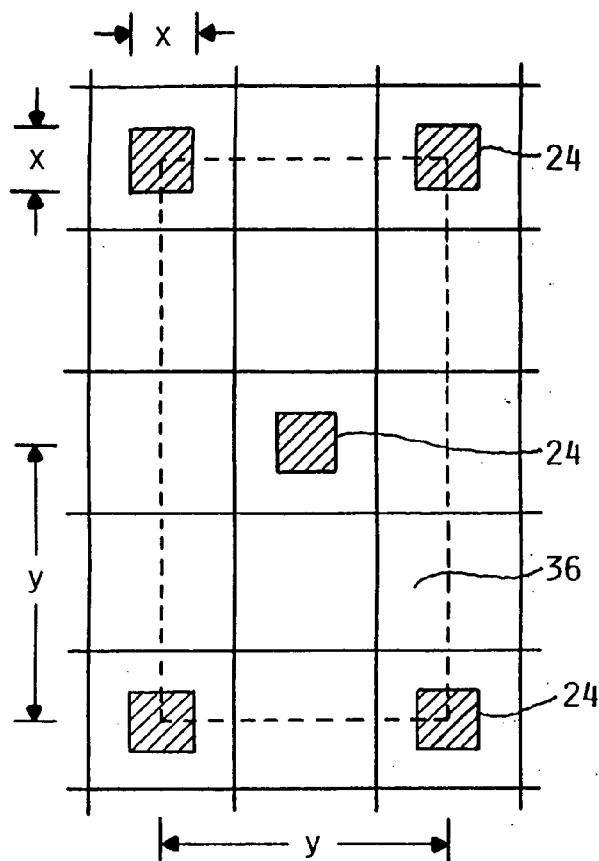

FIG. 4

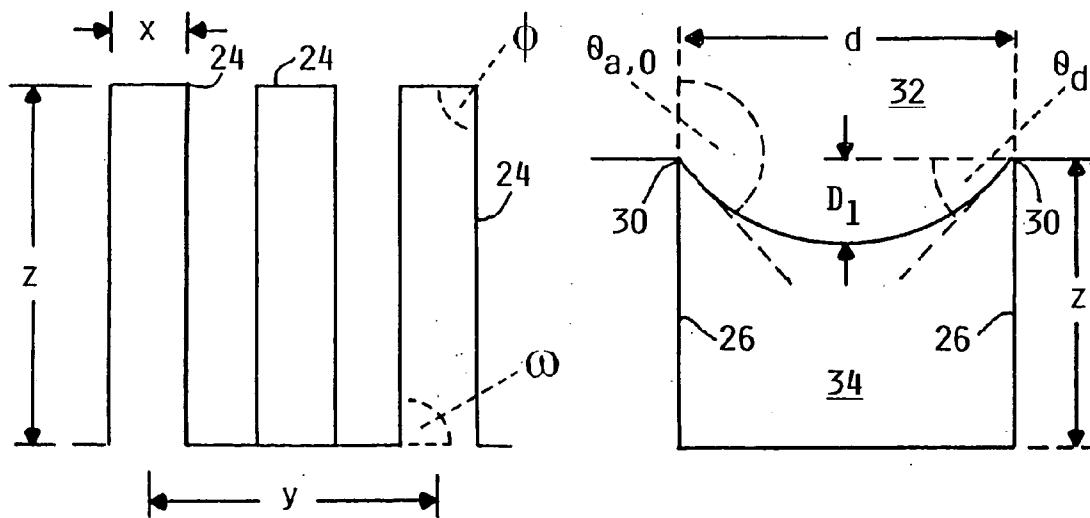

FIG. 5

FIG. 6

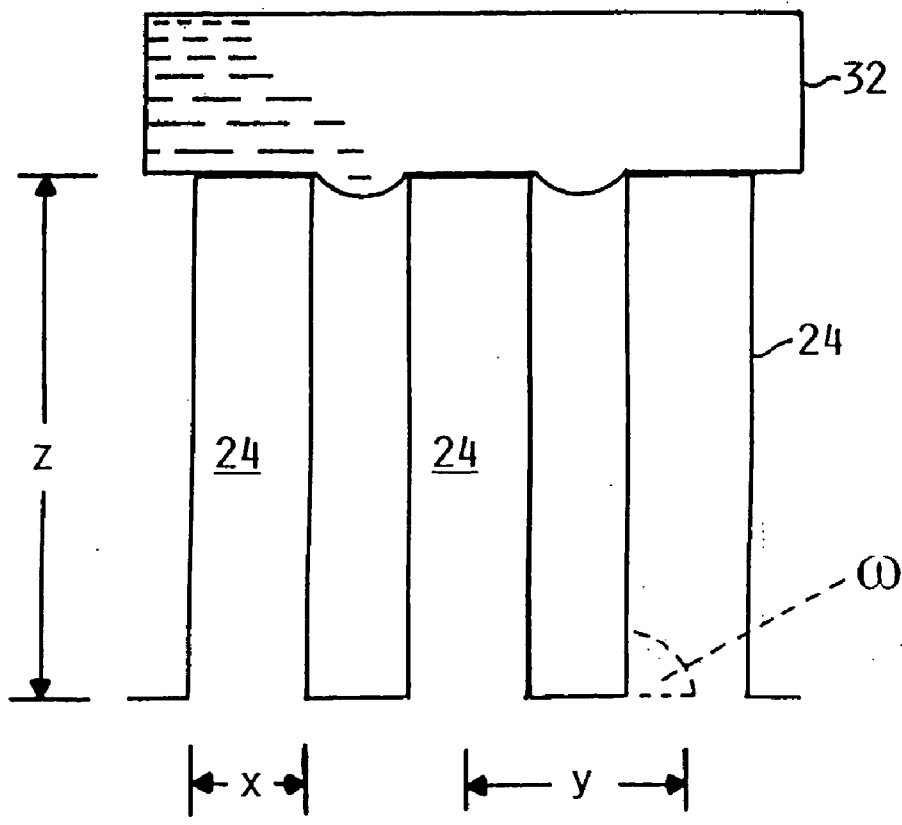

FIG. 7

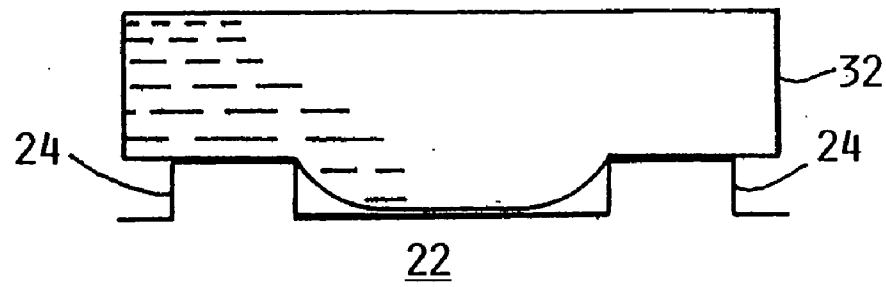

FIG. 8

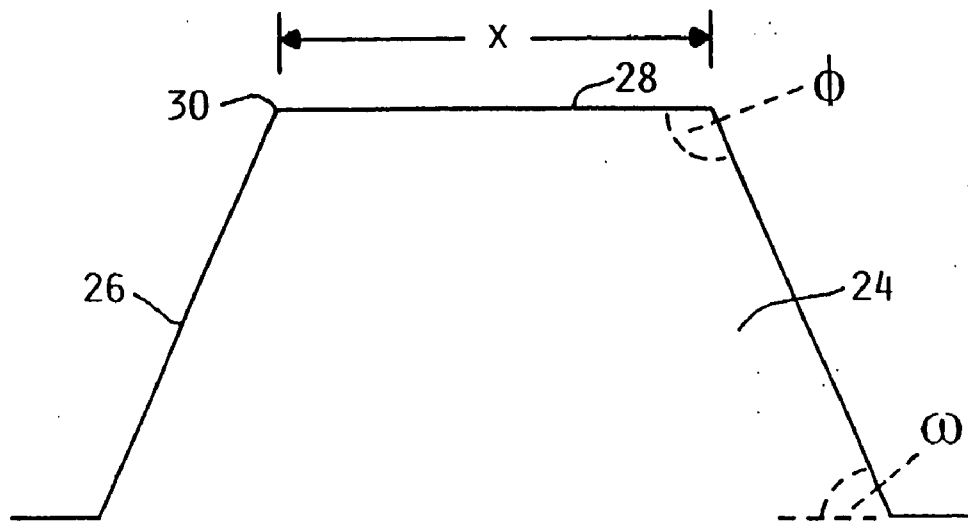

FIG. 9

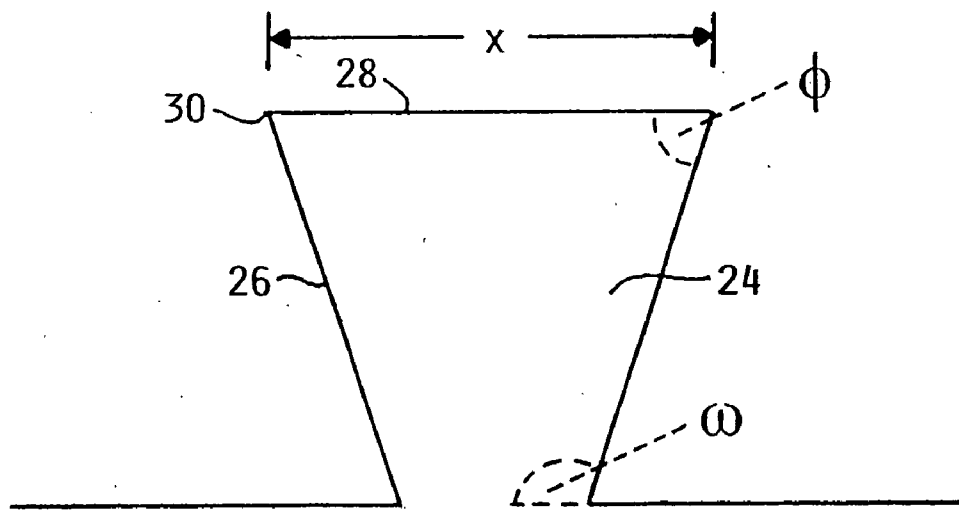

FIG. 10

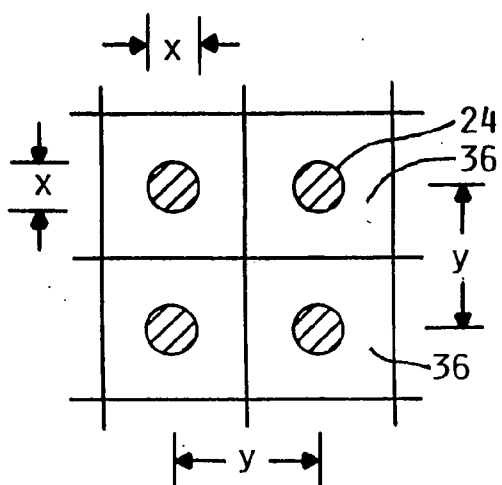

FIG. 11

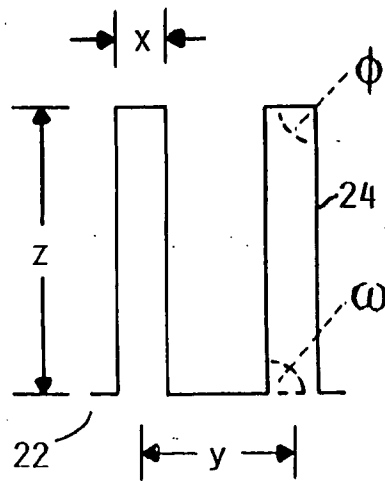

FIG. 12

Geometry	Λ
Hexagonal array of square posts	$4x/y^2$
Cubic array of square posts	$4x/y^2$
Cubic array of circular posts	$\pi x/y^2$

FIG. 13

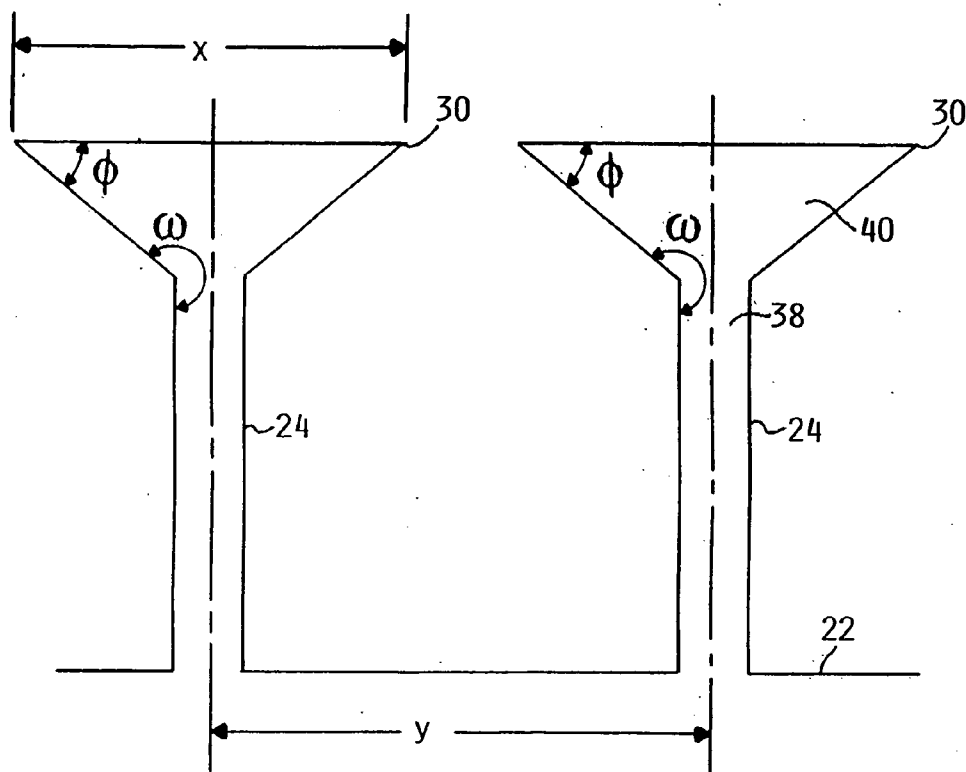

FIG. 14

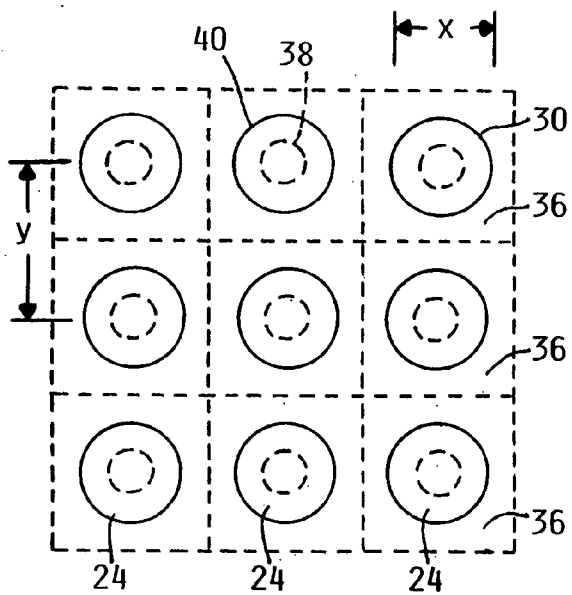

FIG. 15

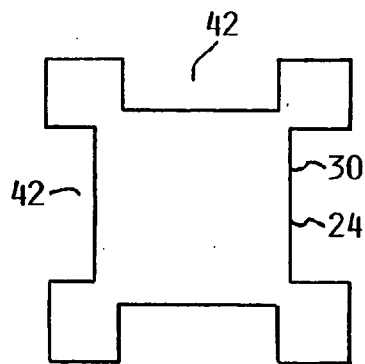

FIG. 16

FLUID HANDLING COMPONENT WITH ULTRAPHOBIC SURFACES

RELATED APPLICATIONS

[0001] This application is a Continuation of application Ser. No. 10/454,742 filed Jun. 3, 2003, entitled "Fluid Handling Component with Ultraphobic Surfaces", which claims the benefit of U.S. Provisional Application Ser. No. 60/462,963, entitled "Ultraphobic Surface for High Pressure Liquids", filed Apr. 15, 2003, hereby fully incorporated herein by reference.

FIELD OF THE INVENTION

[0002] This invention relates generally to fluid handling components, and more specifically to a fluid handling component having ultraphobic fluid contact surfaces.

BACKGROUND OF THE INVENTION

[0003] Fluid handling components, such as channels, pipes, tubes and associated fittings and other components have been used for millennia to convey liquids from one place or process to another. Friction of moving fluids with the fluid handling components, however, has always presented a significant challenge to achieving maximum efficiency in fluid handling systems. Friction increases the energy required to pump a fluid through a system and reduces the fluid flow rate through the system.

[0004] It is known that the physical characteristics of the fluid contact surfaces of fluid handling components have an effect on friction of the fluid with the components. Generally, for example, smoother surfaces reduce friction, while rougher surfaces increase friction. Also, surfaces made from materials resistant to wetting, such as PTFE, exhibit relatively lower fluid friction. Surfaces that are resistant to wetting by liquids are referred to as "phobic" surfaces. Such surfaces may be known as hydrophobic where the liquid is water, and lyophobic relative to other liquids.

[0005] Previous attempts at reducing fluid friction in fluid handling systems have been only partially successful. While fluid friction may be reduced by providing smoother fluid contact surfaces, the amount of reduction achievable is limited. Likewise, the use of conventional materials with improved surface wetting characteristics, such as PTFE, may result in some improvement in friction properties, but the amount of improvement is limited. Also, the choice of materials may be restricted based on the compatibility of the fluid with the materials to be used.

[0006] Some recent work has focused on developing special "ultraphobic" surfaces for use in fluid handling applications, particularly in microfluidic applications. Generally, if a surface resists wetting to an extent that a small droplet of water or other liquid exhibits a very high stationary contact angle with the surface (greater than about 120 degrees), if the surface exhibits a markedly reduced propensity to retain liquid droplets, or if a liquid-gas-solid interface exists at the surface when completely submerged in liquid, the surface may be referred to as an ultrahydrophobic or ultralyophobic surface. For the purposes of this application, the term ultraphobic is used to refer generally to both ultrahydrophobic and ultralyophobic surfaces.

[0007] Friction between a liquid and a surface may be dramatically lower for an ultraphobic surface as opposed to

a conventional surface. As a result, ultraphobic surfaces are extremely desirable for reducing surface friction and increasing flow in a myriad of hydraulic and hydrodynamic applications on a macro scale, and especially in microfluidic applications.

[0008] It is now well known that surface roughness has a significant effect on the degree of surface wetting. It has been generally observed that, under some circumstances, roughness can cause liquid to adhere more strongly to the surface than to a corresponding smooth surface. Under other circumstances, however, roughness may cause the liquid to adhere less strongly to the rough surface than the smooth surface. In some circumstances, the surface may be ultraphobic.

[0009] Efforts have been made previously at introducing intentional roughness on a surface to produce an ultraphobic surface. The roughened surface generally takes the form of a substrate member with a multiplicity of microscale to nanoscale projections or cavities, referred to herein as "asperities".

[0010] Previous attempts at producing ultraphobic surfaces with micro/nanoscale asperities have been only partially successful. Generally, while the prior art surfaces have exhibited ultraphobic properties under some circumstances relative to liquid droplets carefully placed on the surface, the properties generally disappear when a droplet is impacted with the surface or the surface is submerged in liquid.

[0011] Moreover, fluid pressure in fluid handling applications where ultraphobic surfaces may be desirably used often exceeds one atmosphere, and in extreme applications, may reach hundreds of atmospheres. Ultraphobic surfaces produced to date appear to be effective as an ultraphobic surface only up to about 0.1 atmospheres, severely limiting the applicability of such surfaces in fluid handling component applications.

[0012] In addition, prior art ultraphobic surfaces are often formed with delicate polymer or chemical coatings deposited on the substrate. These coatings are easily physically damaged, even by fluid pressure, so as to be ineffective. Fluid handling component applications typically require durable fluid contact surfaces so that the component has a reasonable effective life span.

[0013] Drainability is also often an important characteristic in fluid handling systems. It is typically necessary to drain most fluid handling systems at some time, whether for maintenance or other reasons. For a variety of reasons, it is generally desirable that as much of the fluid as possible be drained from the system at such times. Moreover, it may be critical that substantially all of the fluid is drained from the system in applications such as semiconductor processing in order to minimize undesirable process contamination.

[0014] Often, in conventional fluid handling systems, there is sufficient adhesion between the fluid and the fluid contact surfaces so that individual fluid droplets adhere to the fluid contact surfaces in the system. These droplets are not easily removed, and in a large system, may include a substantial quantity of fluid.

[0015] Still needed in the industry are fluid handling components that provide significantly reduced fluid friction characteristics at pressure, combined with improved drainability characteristics.

SUMMARY OF THE INVENTION

[0016] The invention includes a fluid handling component having a durable ultraphobic fluid contact surface that is capable of exhibiting ultraphobic properties at liquid pressures of one atmosphere and above. The surface generally includes a substrate portion with a multiplicity of projecting regularly shaped microscale or nanoscale asperities disposed so that the surface has a predetermined contact line density measured in meters of contact line per square meter of surface area equal to or greater than a contact line density value “ Λ_L ” determined according to the formula:

$$\Lambda_L = \frac{-10,330}{\gamma \cos(\theta_{a,0} + \omega - 90^\circ)}$$

[0017] where γ is the surface tension of the liquid in Newtons per meter, $\theta_{a,0}$ is the experimentally measured true advancing contact angle of the liquid on the asperity material in degrees, and ω is the asperity rise angle in degrees.

[0018] The asperities may be formed in or on the substrate material itself or in one or more layers of material disposed on the surface of the substrate. The asperities may be any regularly or irregularly shaped three dimensional solid or cavity and may be disposed in any regular geometric pattern or randomly.

[0019] The invention may also include a process for making fluid handling components with fluid contact surfaces having ultraphobic properties at liquid pressures up to a predetermined pressure value. The process includes steps of selecting an asperity rise angle; determining a critical contact line density “ Λ_L ” value according to the formula:

$$\Lambda_L = \frac{-P}{\gamma \cos(\theta_{a,0} + \omega - 90^\circ)}$$

[0020] where P is the predetermined pressure value, γ is the surface tension of the liquid, and $\theta_{a,0}$ is the experimentally measured true advancing contact angle of the liquid on the asperity material in degrees, and ω is the asperity rise angle; providing a substrate member; and forming a multiplicity of projecting asperities on the substrate so that the surface has an actual contact line density equal to or greater than the critical contact line density.

[0021] The asperities may be formed using photolithography, or using nanomachining, microstamping, microcontact printing, self-assembling metal colloid monolayers, atomic force microscopy nanomachining, sol-gel molding, self-assembled monolayer directed patterning, chemical etching, sol-gel stamping, printing with colloidal inks, or by disposing a layer of parallel carbon nanotubes on the substrate. The process may further include the step of determining a critical asperity height value “ Z_c ” in meters according to the formula:

$$Z_c = \frac{d(1 - \cos(\theta_{a,0} + \omega - 180^\circ))}{2 \sin(\theta_{a,0} + \omega - 180^\circ)}$$

[0022] where d is the distance in meters between adjacent asperities, $\theta_{a,0}$ is the true advancing contact angle of the liquid on the surface in degrees, and ω is the asperity rise angle in degrees.

[0023] It is anticipated that fluid handling components having ultraphobic fluid contact surfaces **20** will exhibit sharply reduced fluid friction characteristics, leading to greatly improved fluid handling system efficiencies and improved fluid flow throughput. Drainability will be greatly enhanced due to the tendency of the surface to suspend droplets, causing them to roll freely by gravity in the direction of any surface slope. The ultraphobic surfaces will be durable, and capable of exhibiting ultraphobic properties under fluid pressures up to the design pressure selected according to the method outlined above.

[0024] Other beneficial properties are also anticipated. For example, ultraphobic fluid contact surfaces **20** are anticipated to be resistant to bio-film growth, due to the tendency of the surface to repel liquid water. As a result, the fluid handling components of the present application have applications where inhibition of bio-film growth is desirable, such as for example warm water storage and circulating systems.

BRIEF DESCRIPTION OF THE DRAWINGS

[0025] **FIG. 1a** is a partial longitudinal sectional view of a length of tubing with an ultraphobic fluid contact surface according to the present invention;

[0026] **FIG. 1b** is a cross-sectional view of the length of tubing depicted in **FIG. 1a**;

[0027] **FIG. 1c** is a partial longitudinal sectional view of a 90 degree elbow fitting according to the present invention connecting two sections of pipe;

[0028] **FIG. 1d** is a sectional view of a two-way valve component according to the present invention;

[0029] **FIG. 1e** is a sectional view of a three-way valve component according to the present invention;

[0030] **FIG. 1f** is a sectional view of an in-line flowmeter component according to the present invention;

[0031] **FIG. 1g** is a sectional view of an in-line flowmeter sight tube according to the present invention;

[0032] **FIG. 1h** is a perspective, greatly enlarged view of an ultraphobic surface according to the present invention, wherein a multiplicity of nano/micro scale asperities are arranged in a rectangular array;

[0033] **FIG. 2** is a top plan view of a portion of the surface of **FIG. 1**;

[0034] **FIG. 3** is a side elevation view of the surface portion depicted in **FIG. 2**;

[0035] **FIG. 4** is a partial top plan view of an alternative embodiment of the present invention wherein the asperities are arranged in a hexagonal array;

[0036] FIG. 5 is a side elevation view of the alternative embodiment of FIG. 4;

[0037] FIG. 6 is a side elevation view depicting the deflection of liquid suspended between asperities;

[0038] FIG. 7 is a side elevation view depicting a quantity of liquid suspended atop asperities;

[0039] FIG. 8 is a side elevation view depicting the liquid contacting the bottom of the space between asperities;

[0040] FIG. 9 is a side elevation view of a single asperity in an alternative embodiment of the invention wherein the asperity rise angle is an acute angle;

[0041] FIG. 10 is a side elevation view of a single asperity in an alternative embodiment of the invention wherein the asperity rise angle is an obtuse angle;

[0042] FIG. 11 a partial top plan view of an alternative embodiment of the present invention wherein the asperities are cylindrical and are arranged in a rectangular array;

[0043] FIG. 12 is a side elevation view of the alternative embodiment of FIG. 11;

[0044] FIG. 13 is a table listing formulas for contact line density for a variety of asperity shapes and arrangements;

[0045] FIG. 14 is a side elevation view of an alternative embodiment of the present invention;

[0046] FIG. 15 is a top plan view of the alternative embodiment of FIG. 14; and

[0047] FIG. 16 is a top plan view of a single asperity in an alternative embodiment of the present invention.

DETAILED DESCRIPTION OF THE INVENTION

[0048] For the purposes of the present application, the term “fluid handling component” refers broadly to pipe, tubing, fittings, valves, flowmeters, tanks, pumps, and any other device or component that may be used to handle, transport, contain, or convey a fluid. The term “fluid contact surface” refers broadly to any surface or portion thereof of a fluid handling component that may be in contact with a fluid. The term “fluid handling system” refers to any fluidly interconnected arrangement of fluid handling components.

[0049] Various embodiments of fluid handling components according to the present invention are depicted in FIGS. 1a-1g. In FIGS. 1a and 1b, a length of tubing 100 has a body 102 with a bore 104 defined therethrough. Substrate layer 106 is disposed so as to line bore 104. Ultraphobic fluid contact surface 20 is formed on substrate layer 106 and faces inwardly so as to contact fluid flowing through bore 104. Substrate layer 106 may be applied to body 102 by film insert molding as disclosed in co-pending U.S. patent application Ser. No. 10/304,459, entitled “Performance Polymer Film Insert Molding for Fluid Control Devices”, commonly owned by the owners of the present invention and hereby incorporated fully by reference herein. Although a separate substrate layer 106 is depicted in the embodiment of FIGS. 1a and 1b, it will be readily appreciated that in other embodiments, body 102 may serve as the substrate, with ultraphobic fluid contact surface 20 formed directly on an inwardly facing surface thereof. It will also be appreciated that ultraphobic fluid contact surface may run the entire

length of tubing 100 or may be selectively positioned at any desired point where flow conditions may be critical.

[0050] Another embodiment of a fluid handling component in the form of a 90 degree elbow fitting 108 connecting two lengths of pipe 110 is depicted in FIG. 1c. Elbow fitting 108 has a body portion 112 with ultraphobic fluid contact surface 20 directly on inner surface 114. The inner surface 116 of each pipe 118 may also be an ultraphobic contact surface 20. It will, of course, be readily appreciated that ultraphobic fluid contact surface 20 may be provided on pipe, tubing, fittings and channels of any shape or size. For example, although a 90 degree elbow fitting is depicted in FIG. 1c herein, other fittings such as sweep elbows, tees, wye and sanitary fittings, manifolds and the like may also be provided with ultraphobic fluid contact surfaces according to the present invention.

[0051] In addition, other more complex fluid handling components, such as two-position valve 120 depicted in FIG. 1d, may be provided with ultraphobic fluid contact surfaces 20. Two-position valve 120 generally includes a valve body 122 and a valve stem 124. Valve body 122 generally includes an inlet port 126 and an outlet port 128 connected by a continuous flow channel 130. Valve stem 124 includes a handle 132, a rod 134 and a sealing face 136. Ultraphobic fluid contact surface 20 may be formed on the entire wetted surface of two-position valve 120 including inlet port 126, outlet port 128 and flow channel 130 or any desired portion thereof. Ultraphobic fluid contact surface 20 may also be formed on the wetted portions of valve stem 134.

[0052] Another alternative embodiment of a fluid handling component 138 is depicted in FIG. 1e. In FIG. 1e, a three-position valve 140 includes a valve body 142 having an inlet port 144, a first outlet port 146 and a second outlet port 148. Three-position valve 140 also includes a valve stem 150 within a central bore 152. First outlet port 146 and second outlet port 148 are configured having barbed ends facilitating interconnection to the remainder of a fluid circuit. Again, ultraphobic fluid contact surface 20 may be formed over the entire wetted surface of valve body 142 and valve stem 150, or selectively on any portion thereof.

[0053] It will be evident that ultraphobic fluid contact surface 20 may be applied to any valve configuration. These configurations could include any number of inlet and outlet ports, all variety of valve connections including male and female, threaded style connectors and, sanitary connectors. In addition, ultraphobic fluid contact surfaces according to the present invention may be selectively applied to the wide variety of valve stems including those used in ball valves, gate valves, and diaphragm valves.

[0054] As depicted in FIGS. 1f and 1g, the fluid handling component may be in the form of a flowmeter assembly 154. Flowmeter assembly 154 generally includes an inlet port 156, an outlet port 158, a sight tube 160 and a float 162. In the depicted embodiment, ultraphobic fluid contact surface 20 is formed on all wetted surfaces of flowmeter assembly 154. In the alternative embodiment depicted in FIG. 1g, sight tube 160 has an interior substrate layer 164, with the ultraphobic fluid contact surface 20 on the interior surface 166 of substrate layer 164. It will be appreciated that ultraphobic fluid contact surfaces 20 may be applied to any type of fluid monitoring apparatus, including flowmeters having sensors for transmitting fluid flow data. In such an

embodiment, ultraphobic fluid contact surface **20** may be formed on a sensor utilizing a paddle wheel, turbine, magnet or other flow sensing device commonly used in industry.

[0055] In sum, it will be appreciated that ultraphobic fluid contact surface **20** may be applied to any fluid handling component where such properties may be desirable. Other examples of such fluid handling components may include fluid moving devices such as pumps, nozzles, weirs, and hydraulic components such as cylinders. It will also be readily appreciated that the ultraphobic fluid contact surface **20** of the present invention may be advantageously applied to microfluidic fluid handling components, particularly where higher fluid pressures may be used.

[0056] Turning now to FIG. 1h, a greatly enlarged view of ultraphobic fluid contact surface **20** is depicted. The surface **20** generally includes a substrate **22** with a multiplicity of projecting asperities **24**. Each asperity **24** has a plurality of sides **26** and a top **28**. Each asperity **24** has a width dimension, annotated "x" in the figures, and a height dimension, annotated "z" in the figures. Each asperity spaced apart from the adjacent asperities by a spacing dimension, annotated "y" in the figures. The angle subtended by the top edge **30** of the asperities **24** is annotated ϕ , and the rise angle of the side **26** of the asperities **24** relative to the substrate **22** is annotated ω . The sum of the angles ϕ and ω is 180 degrees.

[0057] Generally, ultraphobic fluid contact surface **20** will exhibit ultraphobic properties when a liquid-solid-gas interface is maintained at the surface. As depicted in FIG. 7, if liquid **32** contacts only the tops **28** and a portion of the sides **26** proximate top edge **30** of asperities **24**, leaving a space **34** between the asperities filled with air or other gas, the requisite liquid-solid-gas interface is present. The liquid may be said to be "suspended" atop and between the top edges **30** of the asperities **24**.

[0058] As will be disclosed hereinbelow, the formation of the liquid-solid-gas interface depends on certain interrelated geometrical parameters of the asperities **24** and the properties of the liquid. According to the present invention, the geometrical properties of asperities **24** may be selected so that the surface **20** exhibits ultraphobic properties at any desired liquid pressure.

[0059] Referring to the rectangular array of FIGS. 1h-3, surface **20** may be divided into uniform areas **36**, depicted bounded by dashed lines, surrounding each asperity **24**. The area density of asperities (δ) in each uniform area **36** may be described by the equation:

$$\delta = \frac{1}{2y^2}, \tag{1}$$

[0060] where y is the spacing between asperities measured in meters.

[0061] For asperities **24** with a square cross-section as depicted in FIGS. 1h-3, the length of perimeter (p) of top **28** at top edge **30**:

$$p=4x, \tag{2}$$

[0062] where x is the asperity width in meters.

[0063] Perimeter p may be referred to as a "contact line" defining the location of the liquid-solid-gas interface. The contact line density (Λ) of the surface, which is the length of contact line per unit area of the surface, is the product of the perimeter (p) and the area density of asperities (δ) so that:

$$\Lambda=p\delta. \tag{3}$$

[0064] For the rectangular array of square asperities depicted in FIGS. 1-3:

$$\Lambda=4x/y^2. \tag{4}$$

[0065] A quantity of liquid will be suspended atop asperities **24** if the body forces (F) due to gravity acting on the liquid are less than surface forces (f) acting at the contact line with the asperities. Body forces (F) associated with gravity may be determined according to the following formula:

$$F=\rho gh, \tag{5}$$

[0066] where g is the density (ρ) of the liquid, (g) is the acceleration due to gravity, and (h) is the depth of the liquid. Thus, for example, for a 10 meter column of water having an approximate density of 1000 kg/m³, the body forces (F) would be:

$$F=(1000 \text{ kg/m}^3)(9.8 \text{ m/s}^2)(10 \text{ m})=9.8 \times 10^4 \text{ kg/m}^2\text{-s}.$$

[0067] On the other hand, the surface forces (f) depend on the surface tension of the liquid (γ), its apparent contact angle with the side **26** of the asperities **24** with respect to the vertical θ_s , the contact line density of the asperities (Λ) and the apparent contact area of the liquid (A):

$$f=-\Lambda\gamma \cos \theta_s. \tag{6}$$

[0068] The true advancing contact angle ($\theta_{a,0}$) of a liquid on a given solid material is defined as the largest experimentally measured stationary contact angle of the liquid on a surface of the material having essentially no asperities. The true advancing contact angle is readily measurable by techniques well known in the art.

[0069] Suspended drops on a surface with asperities exhibit their true advancing contact angle value ($\theta_{a,0}$) at the sides of the asperities. The contact angle with respect to the vertical at the side of the asperities (θ_s) is related to the true advancing contact angle ($\theta_{a,0}$) by ϕ or ω as follows:

$$\theta_s=\theta_{a,0}+90^\circ-\phi=\theta_{a,0}+\omega-90^\circ. \tag{7}$$

[0070] By equating F and f and solving for contact line density Λ , a critical contact line density parameter Λ_L may be determined for predicting ultraphobic properties in a surface:

$$\Lambda_L = \frac{-\rho gh}{\gamma \cos(\theta_{a,0} + \omega - 90^\circ)}, \tag{8}$$

[0071] where g is the density (ρ) of the liquid, (g) is the acceleration due to gravity, (h) is the depth of the liquid, the surface tension of the liquid (γ), ω is the rise angle of the side of the asperities relative to the substrate in degrees, and ($\theta_{a,0}$) is the experimentally measured true advancing contact angle of the liquid on the asperity material in degrees.

[0072] If $\Lambda > \Lambda_L$, the liquid will be suspended atop the asperities **24**, producing an ultraphobic surface. Otherwise, if $\Lambda < \Lambda_L$, the liquid will collapse over the asperities and the

contact interface at the surface will be solely liquid/solid, without ultraphobic properties.

[0073] It will be appreciated that by substituting an appropriate value in the numerator of the equation given above, a value of critical contact line density may be determined to design a surface that will retain ultraphobic properties at any desired amount of pressure. The equation may be generalized as:

$$\Lambda_L = \frac{-P}{\gamma \cos(\theta_{a,0} + \omega - 90^\circ)}, \quad (9)$$

[0074] where P is the maximum pressure under which the surface must exhibit ultraphobic properties in kilograms per square meter, γ is the surface tension of the liquid in Newtons per meter, $\theta_{a,0}$ is the experimentally measured true advancing contact angle of the liquid on the asperity material in degrees, and ω is the asperity rise angle in degrees.

[0075] It is generally anticipated that a surface **20** formed according to the above relations will exhibit ultraphobic properties under any liquid pressure values up to and including the value of P used in equation (9) above. The ultraphobic properties will be exhibited whether the surface is submerged, subjected to a jet or spray of liquid, or impacted with individual droplets.

[0076] According to the above relations, surface **20** will exhibit ultraphobic properties at a liquid pressure of one atmosphere, equal to about 10,330 kg/m², where the contact line density Λ of surface **20** equals or exceeds a critical contact line density Λ_L determined as follows:

$$\Lambda_L = \frac{-10,330}{\gamma \cos(\theta_{a,0} + \omega - 90^\circ)}, \quad (10)$$

[0077] where γ is the surface tension of the liquid in Newtons per meter, $\theta_{a,0}$ is the experimentally measured true advancing contact angle of the liquid on the asperity material in degrees, and ω is the asperity rise angle in degrees.

[0078] Once the value of critical contact line density is determined, the remaining details of the geometry of the asperities may be determined according to the relationship of x and y given in the equation for contact line density. In other words, the geometry of the surface may be determined by choosing the value of either x or y in the contact line equation and solving for the other variable.

[0079] The liquid interface deflects downwardly between adjacent asperities by an amount D_1 as depicted in FIG. 6. If the amount D_1 is greater than the height (z) of the asperities **24**, the liquid will contact the substrate **22** at a point between the asperities **24**. If this occurs, the liquid will be drawn into space **34**, and collapse over the asperities, destroying the ultraphobic character of the surface. The value of D_1 represents a critical asperity height (Z_c), and is determinable according to the following formula:

$$D_1 = Z_c = \frac{d(1 - \cos(\theta_{a,0} + \omega - 180^\circ))}{2 \sin(\theta_{a,0} + \omega - 180^\circ)}, \quad (11)$$

[0080] where (d) is the distance between adjacent asperities, ω is the asperity rise angle, and $\theta_{a,0}$ is the experimentally measured true advancing contact angle of the liquid on the asperity material. The height (z) of asperities **24** must be at least equal to, and is preferably greater than, critical asperity height (Z_c).

[0081] Although in FIGS. 1h-3 the asperity rise angle ω is 90 degrees, other asperity geometries are possible. For example, ω may be an acute angle as depicted in FIG. 9 or an obtuse angle as depicted in FIG. 10. Generally, it is preferred that ω be between 80 and 130 degrees.

[0082] It will also be appreciated that a wide variety of asperity shapes and arrangements are possible within the scope of the present invention. For example, asperities may be polyhedral, cylindrical as depicted in FIGS. 11-12, cylindroid, or any other suitable three dimensional shape. In addition, various strategies may be utilized to maximize contact line density of the asperities. As depicted in FIGS. 14 and 15, the asperities **24** may be formed with a base portion **38** and a head portion **40**. The larger perimeter of head portion **40** at top edge **30** increases the contact line density of the surface. Also, features such as recesses **42** may be formed in the asperities **24** as depicted in FIG. 16 to increase the perimeter at top edge **30**, thereby increasing contact line density. The asperities may also be cavities formed in the substrate.

[0083] The asperities may be arranged in a rectangular array as discussed above, in a polygonal array such as the hexagonal array depicted in FIGS. 4-5, or a circular or ovoid arrangement. The asperities may also be randomly distributed so long as the critical contact line density is maintained, although such a random arrangement may have less predictable ultraphobic properties, and is therefore less preferred. In such a random arrangement of asperities, the critical contact line density and other relevant parameters may be conceptualized as averages for the surface. In the table of FIG. 13, formulas for calculating contact line densities for various other asperity shapes and arrangements are listed.

[0084] Generally, the substrate material may be any material upon which micro or nano scale asperities may be suitably formed. The asperities may be formed directly in the substrate material itself, or in one or more layers of other material deposited on the substrate material, by photolithography or any of a variety of suitable methods. A photolithography method that may be suitable for forming micro/nanoscale asperities is disclosed in PCT Patent Application Publication WO 02/084340, hereby fully incorporated herein by reference.

[0085] Other methods that may be suitable for forming asperities of the desired shape and spacing include nanomachining as disclosed in U.S. Patent Application Publication No. 2002/00334879, microstamping as disclosed in U.S. Pat. No. 5,725,788, microcontact printing as disclosed in U.S. Pat. No. 5,900,160, self-assembled metal colloid monolayers, as disclosed in U.S. Pat. No. 5,609,907, microstamping as disclosed in U.S. Pat. No. 6,444,254, atomic force

microscopy nanomachining as disclosed in U.S. Pat. No. 5,252,835, nanomachining as disclosed in U.S. Pat. No. 6,403,388, sol-gel molding as disclosed in U.S. Pat. No. 6,530,554, self-assembled monolayer directed patterning of surfaces, as disclosed in U.S. Pat. No. 6,518,168, chemical etching as disclosed in U.S. Pat. No. 6,541,389, or sol-gel stamping as disclosed in U.S. Patent Application Publication No. 2003/0047822, all of which are hereby fully incorporated herein by reference. Carbon nanotube structures may also be usable to form the desired asperity geometries. Examples of carbon nanotube structures are disclosed in U.S. Patent Application Publication Nos. 2002/0098135 and 2002/0136683, also hereby fully incorporated herein by reference. Also, suitable asperity structures may be formed using known methods of printing with colloidal inks. Of course, it will be appreciated that any other method by which micro/nanoscale asperities may be accurately formed may also be used.

[0086] It is anticipated that fluid handling components having ultraphobic fluid contact surfaces **20** will exhibit sharply reduced fluid friction characteristics, leading to greatly improved fluid handling system efficiencies and improved fluid flow throughput. Drainability will be greatly enhanced due to the tendency of the surface to suspend droplets, causing them to roll freely by gravity in the direction of any surface slope. The ultraphobic surfaces will be durable, and capable of exhibiting ultraphobic properties under fluid pressures up to the design pressure selected according to the method outlined above.

[0087] Other beneficial properties are also anticipated. For example, ultraphobic fluid contact surfaces **20** are anticipated to be resistant to bio-film growth, due to the tendency of the surface to repel liquid water. As a result, the fluid handling components of the present application have applications where inhibition of bio-film growth is desirable, such as for example warm water storage and circulating systems.

What is claimed is:

1. A fluid handling component comprising:

a body having at least one fluid contact surface portion, said fluid contact surface portion including a substrate with a multiplicity of substantially uniformly shaped asperities thereon, each asperity having a common asperity rise angle relative to the substrate, the asperities positioned so that the surface has a contact line density measured in meters of contact line per square meter of surface area equal to or greater than a contact line density value " Λ_L " determined according to the formula:

$$\Lambda_L = \frac{-10,330}{\gamma \cos(\theta_{a,0} + \omega - 90^\circ)}$$

where γ is the surface tension of a fluid in contact with the surface in Newtons per meter, $\theta_{a,0}$ is the experimentally measured true advancing contact angle of the fluid on the asperity material in degrees, and ω is the asperity rise angle in degrees, wherein the surface exhibits a liquid-solid-gas interface with the fluid at a pressure of at least one atmosphere.

2. The component of claim 1, wherein the asperities are projections.

3. The component of claim 2, wherein the asperities are polyhedrally shaped.

4. The component of claim 2, wherein each asperity has a generally square transverse cross-section.

5. The component of claim 2, wherein the asperities are cylindrical or cylindroidally shaped.

6. The component of claim 1, wherein the asperities are cavities formed in the substrate.

7. The component of claim 1, wherein the asperities are positioned in a substantially uniform array.

8. The component of claim 7, wherein the asperities are positioned in a rectangular array.

9. The component of claim 1, wherein the asperities have a substantially uniform asperity height relative to the substrate portion, and wherein the asperity height is greater than a critical asperity height value " Z_c " in meters determined according to the formula:

$$Z_c = \frac{d(1 - \cos(\theta_{a,0} + \omega - 180^\circ))}{2\sin(\theta_{a,0} + \omega - 180^\circ)}$$

where d is the distance in meters between adjacent asperities, $\theta_{a,0}$ is the experimentally measured true advancing contact angle of the liquid on the asperity material in degrees, and ω is the asperity rise angle in degrees.

10. The component of claim 1, wherein the component includes a tube having a bore with an inner surface, and wherein the at least one fluid contact surface portion is on said inner surface.

11. The component of claim 1, wherein the component is a valve.

12. The component of claim 1, wherein the component is a fluid moving device.

13. The component of claim 12, wherein the fluid moving device is a pump.

14. A process of making a fluid handling component having an ultraphobic fluid contact surface adapted for repelling a liquid at a pressure of at least one atmosphere in contact with the surface, the process comprising:

providing a fluid handling component including a substrate having an outer surface; and

forming a multiplicity of substantially uniformly shaped asperities on the outer surface of the substrate, each asperity having a common asperity rise angle relative to the substrate portion, the asperities positioned so that the surface has a contact line density measured in meters of contact line per square meter of surface area equal to or greater than a contact line density value " Λ_L " determined according to the formula:

$$\Lambda_L = \frac{-10,330}{\gamma \cos(\theta_{a,0} + \omega - 90^\circ)}$$

where γ is the surface tension of the liquid in Newtons per meter, $\theta_{a,0}$ is the experimentally measured true advancing contact angle of the liquid on the asperity material in degrees, and ω is the asperity rise angle in degrees.

15. The process of claim 14, wherein the asperities are formed by photolithography.

16. The process of claim 14, wherein the asperities are formed by a process selected from the group consisting of nanomachining, microstamping, microcontact printing, self-assembling metal colloid monolayers, atomic force microscopy nanomachining, sol-gel molding, self-assembled monolayer directed patterning, chemical etching, sol-gel stamping, printing with colloidal inks, and disposing a layer of parallel carbon nanotubes on the substrate.

17. A process for producing a fluid handling component having a fluid contact surface with ultraphobic properties at liquid pressures up to a predetermined pressure value, the process comprising:

selecting an asperity rise angle;

determining a critical contact line density “ Λ_L ” value according to the formula:

$$\Lambda_L = \frac{-P}{\gamma \cos(\theta_{a,0} + \omega - 90^\circ)}$$

where P is the predetermined pressure value, γ is the surface tension of the liquid, $\theta_{a,0}$ is the experimentally measured true advancing contact angle of the liquid on the asperity material in degrees, and ω is the asperity rise angle;

providing a fluid handling component having a substrate; and

forming a multiplicity of projecting asperities on the substrate so that the surface has an actual contact line density equal to or greater than the critical contact line density.

18. The process of claim 17, wherein the asperities are formed using photolithography.

19. The process of claim 17, wherein the asperities are formed using wherein the asperities are formed using nanomachining, microstamping, microcontact printing, self-assembling metal colloid monolayers, atomic force microscopy nanomachining, sol-gel molding, self-assembled monolayer directed patterning, chemical etching, sol-gel stamping, printing with colloidal inks, or by disposing a layer of parallel carbon nanotubes on the substrate.

20. The process of claim 17, further comprising the step of selecting a geometrical shape for the asperities.

21. The process of claim 17, further comprising the step of selecting an array pattern for the asperities.

22. The process of claim 17, further comprising the steps of selecting at least one dimension for the asperities and determining at least one other dimension for the asperities using an equation for contact line density.

23. The process of claim 17, further comprising the step of determining a critical asperity height value “ Z_c ” in meters according to the formula:

$$Z_c = \frac{d(1 - \cos(\theta_{a,0} + \omega - 180^\circ))}{2\sin(\theta_{a,0} + \omega - 180^\circ)}$$

where d is the distance in meters between adjacent asperities, $\theta_{a,0}$ is the true advancing contact angle of the liquid on the surface in degrees, and ω is the asperity rise angle in degrees.

24. A fluid handling system comprising:

at least one fluid handling component including a body with at least one fluid contact surface portion, said fluid contact surface portion including a substrate with a multiplicity of substantially uniformly shaped asperities thereon, each asperity having a common asperity rise angle relative to the substrate, the asperities positioned so that the surface has a contact line density measured in meters of contact line per square meter of surface area equal to or greater than a contact line density value “ Λ_L ” determined according to the formula:

$$\Lambda_L = \frac{-10,330}{\gamma \cos(\theta_{a,0} + \omega - 90^\circ)}$$

where γ is the surface tension of a fluid in contact with the surface in Newtons per meter, $\theta_{a,0}$ is the experimentally measured true advancing contact angle of the fluid on the asperity material in degrees, and ω is the asperity rise angle in degrees, wherein the surface exhibits a liquid-solid-gas interface with the fluid at a pressure of at least one atmosphere.

25. The system of claim 24, wherein the asperities are projections.

26. The system of claim 25, wherein the asperities are polyhedrally shaped.

27. The system of claim 25, wherein each asperity has a generally square transverse cross-section.

28. The system of claim 25, wherein the asperities are cylindrical or cylindroidally shaped.

29. The system of claim 24, wherein the asperities are cavities formed in the substrate.

30. The system of claim 24, wherein the asperities are positioned in a substantially uniform array.

31. The system of claim 30, wherein the asperities are positioned in a rectangular array.

32. The system of claim 24, wherein the asperities have a substantially uniform asperity height relative to the substrate portion, and wherein the asperity height is greater than a critical asperity height value “ Z_c ” in meters determined according to the formula:

$$Z_c = \frac{d(1 - \cos(\theta_{a,0} + \omega - 180^\circ))}{2\sin(\theta_{a,0} + \omega - 180^\circ)}$$

where d is the distance in meters between adjacent asperities, $\theta_{a,0}$ is the experimentally measured true advancing contact angle of the liquid on the asperity material in degrees, and ω is the asperity rise angle in degrees.

33. The system of claim 24, wherein the component includes a tube having a bore with an inner surface, and wherein the at least one fluid contact surface portion is on said inner surface.

34. The component of claim 24, wherein the component is a valve.

35. The component of claim 24, wherein the component is a fluid moving device.

36. The component of claim 35, wherein the fluid moving device is a pump.