

(19) World Intellectual Property Organization
International Bureau



(43) International Publication Date
21 September 2006 (21.09.2006)

PCT

(10) International Publication Number
WO 2006/097496 A1

(51) International Patent Classification:
H01Q 1/38 (2006.01) *H01Q 9/04* (2006.01)
H01Q 13/10 (2006.01)

(21) International Application Number:
PCT/EP2006/060766

(22) International Filing Date: 15 March 2006 (15.03.2006)

(25) Filing Language: English

(26) Publication Language: English

(30) Priority Data:
05005540.9 15 March 2005 (15.03.2005) EP

(71) Applicant (for all designated States except US): **FRAC-TUS, S.A.** [ES/ES]; Edificio Testa - Módulo C, 3º, Avda. Alcalde Barnils, 64-68, Parque Empresarial Sant Joan, Sant Gugat Del Vallès, E-08190 Barcelona (ES).

(72) Inventors; and

(75) Inventors/Applicants (for US only): **PUENTE BALIARDA, Carles** [ES/ES]; C/Londres, 57 4º 2a, E-08036 Barcelona (ES). **ANGUERA-PROS, Jaime** [ES/ES]; Paseo Blasco Ibáñez N°15 2º, E-12500 Vinaròs (ES).

(74) Agent: **MILTÉNYI, Peter**; Maximilianstrasse 58, 80538 München (DE).

(81) Designated States (unless otherwise indicated, for every kind of national protection available): AE, AG, AL, AM, AT, AU, AZ, BA, BB, BG, BR, BW, BY, BZ, CA, CH, CN, CO, CR, CU, CZ, DE, DK, DM, DZ, EC, EE, EG, ES, FI, GB, GD, GE, GH, GM, HR, HU, ID, IL, IN, IS, JP, KE, KG, KM, KN, KP, KR, KZ, LC, LK, LR, LS, LT, LU, LV, LY, MA, MD, MG, MK, MN, MW, MX, MZ, NA, NG, NI, NO, NZ, OM, PG, PH, PL, PT, RO, RU, SC, SD, SE, SG, SK, SL, SM, SY, TJ, TM, TN, TR, TT, TZ, UA, UG, US, UZ, VC, VN, YU, ZA, ZM, ZW.

(84) Designated States (unless otherwise indicated, for every kind of regional protection available): ARIPO (BW, GH, GM, KE, LS, MW, MZ, NA, SD, SL, SZ, TZ, UG, ZM, ZW), Eurasian (AM, AZ, BY, KG, KZ, MD, RU, TJ, TM), European (AT, BE, BG, CH, CY, CZ, DE, DK, EE, ES, FI, FR, GB, GR, HU, IE, IS, IT, LT, LU, LV, MC, NL, PL, PT, RO, SE, SI, SK, TR), OAPI (BF, BJ, CF, CG, CI, CM, GA, GN, GQ, GW, ML, MR, NE, SN, TD, TG).

Published:

- with international search report
- before the expiration of the time limit for amending the claims and to be republished in the event of receipt of amendments

For two-letter codes and other abbreviations, refer to the "Guidance Notes on Codes and Abbreviations" appearing at the beginning of each regular issue of the PCT Gazette.

(54) Title: SLOTTED GROUND-PLANE USED AS A SLOT ANTENNA OR USED FOR A PIFA ANTENNA

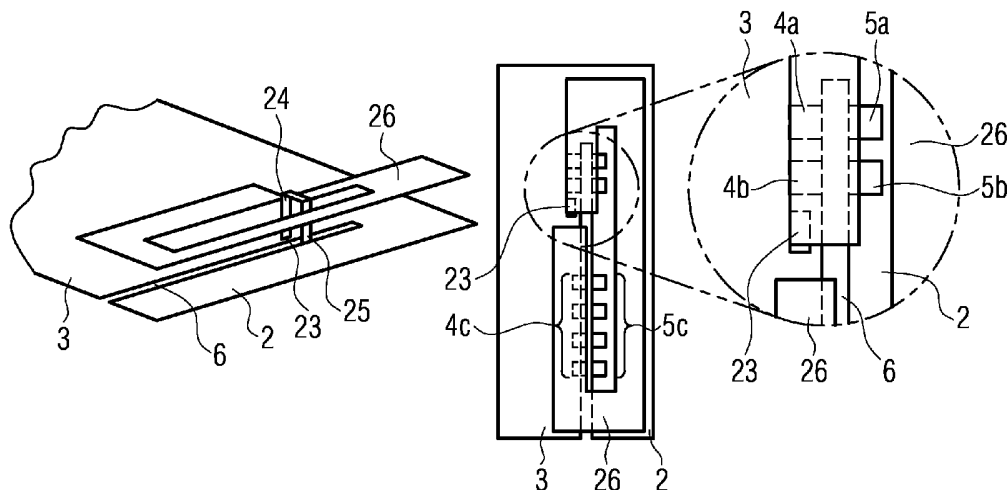

(57) Abstract: The invention refers to a member (1) for a wireless device, wherein that member (1) is or comprises a ground-plane (2, 3) with at least two portions (2, 3), wherein on each of said portions (2, 3) at least one connecting means such as a pad (4, 5) is provided, wherein the two connecting means (4, 5) can be connected with an electric component (10) for connecting said two portions (2, 3) of said ground plane. The invention further refers to a wireless device with such a member and to a wireless device including a ground plane (2, 3) with at least two portions (2, 3) wherein said two portions (2, 3) are connected by an electric component (10), wherein the connection is preferably made between two portions of the ground-plane which are separated by a gap or a slot in the conducting surface of said ground-plane.

WO 2006/097496 A1

SLOTTED GROUND-PLANE USED AS A SLOT ANTENNA OR USED FOR A PIFA ANTENNA

This application is related to the European patent application EP 05005540 filed at the European Patent Office on 15 march 2005. The priority of this application is claimed and this application is incorporated herein by reference.

Shaping the ground-plane of a wireless communication device (such as for instance a mobile phone, a smart phone, a PDA, an MP3 player, headset, USB dongle, laptop, PCMCIA or Cardbus 32 card) has been shown to be a useful technique to improve the radiation characteristics of such a device. This has been for instance disclosed in WO 03 023900. In several examples of the prior-art, at least a portion of such a shaped ground-plane includes a slot separating totally or partially at least two conducting regions on said ground-plane. Further there are several known antenna systems for wireless devices where the radiating antenna element is just a slot provided in the wireless device's ground plane. Usually such a ground-plane is embedded in a multilayer printed circuit board (PCB) which hosts the electronics and other components (for instance integrated circuits, batteries, handset-camera and speakers, LCD screens, vibrators) of the whole device. In these cases, the desired shape for the ground-plane can be cost effectively implemented by using conventional PCB manufacturing techniques.

One of the problems of placing the slot on such a PCB is to make the fine tuning of the frequency response of such a slot, and generally the whole ground-plane. Although several electromagnetic CAD tools can approximately model the response of the geometry, usually the final design is tuned experimentally. This involves an iterative process where several PCBs are to be prototyped and produced before closing the final PCB design. This is a costly process, which in turn might delay the commercial launching of the project.

On the other hand, embedding a slot in the ground-plane some times is difficult due to the size of the slot and space constrains. If a multiband response of the slot is desired, then usually the shape of the slot involves several branches with several characteristic

lengths that can fit the multiple wavelengths. In this later case, again the space is a constraint that can make the solution impractical or unfeasible.

The object of the present invention is to provide a member for a wireless device and / or a wireless device with a ground plane which allows for an improved design process of wireless devices.

This problem is solved with the member of claim 1 and with the wireless device as of claim 16, 17 and / or 19.

The member for the wireless device is or comprises a ground plane with at least two portions. Those two portions are preferably separated by a gap or slot or any other non-conducting part. On each of said portions a connecting means is provided such as a pad or any other connecting means such as a pin, a solder ball or the like. The connecting means are provided such that they can be connected with an electric component. With this electric component the two portions of the ground plane are connectable.

The member may be e.g. a PCB with the ground plane. The ground plane may be an outer layer of the PCB. In case that said PCB is a multilayer board (with multiple conductive layers separated by insulating layers) the outer ground layer shields inner layers. The ground plane may also be provided as an inner layer of a multilayer PCB.

The connecting means are arranged such that an electric component mounted thereon bridges over a non-conducting area.

In this way, it is possible to change the electric characteristics of the ground plane without, however, reshaping the ground plane. The design of the ground plane may therefore be closed while it is still possible to electrically change the ground plane in order to provide improved radiation characteristics.

The two portions of the ground plane may be connected through the ground plane itself such as by a third portion of the ground plane. They may, however, also be disconnected as long as no electric component is connecting the two portions.

The connecting means may have a size such that only one electric component may be connected thereon. The connecting means, however, may also be shaped such that more than one electric component can be provided thereon. The connecting means may e.g. extend without any discontinuity at least along one fifth, fourth, third or half or two thirds, three fourth, three fifth, four fifth or along the entire of the length of one edge of a slot or gap. The two connecting means may also be given by two joint parts of a connecting means which extends around an end of a slot, such that one uninterrupted portion of the connecting means is provided on both sides of the slot. Then it is still possible to bridge the slot by an electric component. The connecting means may also extend continuously all along the edge of a slot such that the two connecting means are given by two parts on different sides of a slot.

The ground plane may for example comprise a slot and the two portions are provided on different sides of the slot. The slot may penetrate all through the ground plane or may only partially penetrate into the ground plane. In the latter case, the two portions are still connected by a third portion of the ground plane, while if the slot penetrates all through the ground plane, the two portions are not connected by another portion of the ground plane.

The slot may have only one part. The slot may also comprise several parts such as two, three or more parts. One part may branch off another part and one, two, three or more parts branching off another part may be given.

The slot may be given in order to enhance radiation characteristics of the wireless device. The slot length may define an operating frequency and/or the slot may be electromagnetically coupled to an antenna element in order to improve the radiation characteristics of the antenna element and therefore of the antenna system as a whole. The electric component may be provided for fine tuning the electric characteristics of the slot and/or ground plane. It may also be provided to define the basic electric characteristics of the slot e.g. by a short circuit element. In this case an additional electric component may be provided in order to fine tune the electric properties of the slot and/or ground plane.

The connecting means are preferably provided around the edges of the slot. This means that they are located at the edge of the slot and are distributed around the

border of the slot. They may be provided directly at the edge or also a little bit separated from the edge. Further, they may be evenly distributed at least on one side or on two sides of the slot along the length of the slot, but they may also be unevenly distributed at least on some portions of the edge of the slot.

One, both or each of the portions of the ground plane may have multiple connecting means such as more than two, three, four, five, seven, ten, fifteen, twenty, thirty, forty or fifty connecting means or less than any of those given numbers. This allows for more flexibility when changing the electric characteristics of the ground plane by connecting the electric component(s).

The ground plane, furthermore, has one, two, three or more connecting means for connecting the ground plane to a feeding and / or radiating element. In some antenna configurations the radiating element may e.g. be short-connected to the ground plane.

The member preferably comprises an insulating material which is partially covering the ground plane. With this insulating material it is possible to define the connecting means by leaving part of the ground plane uncovered. In this way it is easily and cheaply possible to define the different connecting means. The insulating material may be e.g. a paint, a coating, a foil and can be made of e.g. a resin.

The insulating material is preferably further provided such that it is present between different connecting means such that they are clearly separated. This allows for well defined locations of the connecting means such that if the electric component is provided on the connecting means at slightly different positions due to production tolerances, then the portions of the ground plane which are connected are, however, still clearly defined. Thereby it is possible to avoid a major dependence on the electric characteristics of the ground plane due to fabrication tolerances in the exact location of the electric component.

The connecting means may, however, also be given by a pad that is connected to the ground plane with a via, that extends into a multilayer PCB. In this case the ground plane is provided as an inner conductive layer.

The electric component may e.g. be a resistor, a short circuit element, a capacitor, a conductor, a filter, a diode, a transistor, a switch or any other radio frequency device as explained in more detail below.

The connection between the different portions may be established by more than one electric component e.g. by two, three or more electric components. Two or three or more of those components may be arranged in series and/or parallel. Further, the electric components may be the same, different or some of them may be the same or different. This allows for very increased flexibility in adapting the electric properties of the ground plane.

The ground plane may be coupled to one or more antenna elements. The coupling may be by direct electric connection or by coupling with electric/electromagnetic fields through a separation between the antenna element/antenna elements and the ground plane. In a preferred mode, the antenna element is an inverted F antenna (IFA) or, more preferably, a planar inverted F antenna (PIFA). The antenna may be a patch antenna since this allows for a compact design of the wireless device.

The connecting means and the antenna element may be provided on the same side or on different sides of the ground plane/PCB.

Preferably, the slot is placed substantially close to the antenna element such that the coupling between the slot and the antenna element is enhanced. Preferably the slot would be placed at a location which is provided by an orthogonal projection of the antenna onto the ground plane. Preferably, the slot is provided substantially aligned with an edge of the antenna and/or of the ground plane.

A feeding terminal and a shorting terminal of said antenna element(s) may be provided on the same portion of the ground plane but they may also be provided on the two different portions of said ground plane.

Preferably the member further comprises or is given by a circuit board on which or in which the ground plane is provided. The circuit board may be a multi-layer circuit board wherein one conductive layer forms the ground plane.

The ground plane may host other components of the wireless device such as other electronic parts, a frequency generator/receiver for the wireless operation, other integrated circuits, a battery, a key pad, a speaker, a camera, a display, a vibrator, etc.

The ground plane is not necessarily "plane" since it may also be curved, bent or provided with steps. Sometimes, instead of to a ground plane, it is also referred to a ground counterpoise, which refers to the same.

The electric component preferably is or comprises a surface mount device. In fabrication technologies of wireless devices, surface mounting of devices is common and, therefore, in the production of the members for wireless devices surface mount technology is highly favorable. The electric component, however, may also be or comprise a bonding wire. This is suitable, in particular, for providing a short circuit element or a good electric connection between two other electric components used for tuning the electrical ground plane properties.

The wireless device of the present invention comprises a member as mentioned beforehand. In that wireless device in general one or more pair of connecting means may be connected by an electric component. It is, however, also possible, that none of the connecting means is connected to an electric component in case that the ground plane fits with the electrical requirements without any electric component.

In general some of the connecting means and in particular the majority thereof are unconnected since they only provide for the possibility to connect an electric component but in general there will be many connecting means a few of which are chosen from for connection, while a larger number will be left unconnected, since a connection thereof does not provide for the desired electrical characteristic of the ground plane.

Alternatively, the present invention consists of a wireless device (such as for instance a mobile phone, a smartphone, a PDA, an MP3 player, headset, USB dongle, laptop, PCMCIA or Cardbus 32 card) including a reconfigurable ground-plane. This is achieved by interconnecting an electric component with at least two portions of the conducting surface of said ground-plane. Usually, the interconnection is preferably made between two portions of the ground-plane, said portions being separated by a gap or a slot on the

conducting surface of said ground-plane. Said component modifies the radiation frequency response of said slot and the combination of said slot with said electric component modifies the electromagnetic and radiation frequency response of the antenna system and therefore of the entire wireless device.

Another aspect of the invention refers to the above-described reconfigurable ground-plane for a wireless device.

Such a general electric component, is for instance chosen from the following set: a resistor, a short circuit element, a capacitor, an inductor, a filter, a diode, a transistor, a switch or other kind of radio frequency devices. Any combination of them is possible.

Generally, the ground-plane within said wireless device can include more than one gap or slot separating totally or partially several grounding areas on said ground-plane. One or more electric components can be placed in one or more of said slots in said ground-plane.

In some embodiments, the present invention is used to enhance the radiation characteristics of the wireless device. For instance, the slot length can be tuned to resonate at a desired wavelength, such radiation is enhanced around such a particular wavelength. This can be used to increase the number of operating frequency bands of the wireless device, to increase the bandwidth of one or more of the bands, or a combination of both effects. When no component is applied, typically the slot will resonate at an odd multiple of a quarter wavelength (if the slot is opened at one tip and shorted at the opposite one), or at a multiple of half a wavelength (if the slot has both ends shorted or opened with respect to the ground-plane). By introducing an electric component according to the present invention, this behavior can be modified. In particular, the following effects, or a combination of them can be obtained in several arrangements:

Embodiment 1

The component is a short circuit (or a low resistance component) e.g. interconnecting opposite edges of the slot. The effect is that the slot becomes electrically shorter and

the resonance frequency of the slot is changed, typically to shorter wavelengths (higher frequencies).

Embodiment 2

The component is a capacitor e.g. interconnecting opposite edges of the slot. Such a capacitor will have a frequency selective behavior, shorting both edges at a desired operating frequency. As a result, the slot will change its resonant frequency and/or introduce a new non-harmonic resonance that might be used to tune multiple frequency bands in the wireless device. Also, a bandwidth enhancement at a particular frequency band can be obtained by combining the natural resonance of the unloaded slot (a slot without any electric component), and the reactive response of the electric component. This arrangement can be used advantageously for a shortened length of the slot in case of space constraints on the PCB.

Embodiment 3

The component is an inductor e.g. interconnecting opposite edges of the slot. Such an inductor will have a frequency selective behavior, shorting both edges at a desired operating frequency. As a result, the slot will change its resonant frequency and/or introduce a new non-harmonic resonance that might be used to tune multiple frequency bands in the wireless device. Also, a bandwidth enhancement at a particular frequency band can be obtained by combining the natural resonance of the unloaded slot, and the reactive response of the electric component. This arrangement can be used advantageously for a shortened length of the slot in case of space constraints on the PCB.

Embodiment 4

The component is a filter e.g. interconnecting opposite edges of the slot. Such a filter will allow some frequencies to cross over the slot while rejecting others. As a result, the slot will change its resonant frequency and/or introduce a new non-harmonic resonance that might be used to tune multiple frequency bands in the wireless device. Also, a bandwidth enhancement at a particular frequency band can be obtained by combining the natural resonance of the unloaded slot, and the reactive response of the

electric component. This arrangement can be used advantageously for a shortened length of the slot in case of space constraints on the PCB.

Embodiment 5

The component is a switch, a diode (such as for instance a PIN diode, a shotky diode) or a transistor that can be for instance used to switch on and off the connection between the two portions such as the two opposite edges of the slot. Again, this can be used to switch on and off some of the resonance frequencies of the slot, which in combination with the shape of the ground plane and the radiating elements (such as for instance antenna elements) placed over or coupled to such a ground-plane, can modify the frequency response (number of bands, bandwidth, impedance matching characteristics) of the wireless device. Commutation or combination of transmitted and/or received multiple radio signals can be obtained this way.

The switch or transistor can be connected to an electronic processor of the wireless device which can select the desired electric characteristic of the ground plane.

The components and effects mentioned in the above embodiments can be combined in any way.

Embodiment 6

In a preferred embodiment, which may be combined with any of the above embodiments, at least one of the slots in such a ground-plane will include one or more pads grounded at one or more of the edges of said slot, in such a way an electrical / electronic / RF component can be placed over the slot and interconnecting both sides of the slot. In other embodiments, the wireless device includes more than one of those pads or pair of pads around the slot, such that the optimum placement of the component can be tested and fixed without changing the prototyping and manufacturing of the PCB.

This is an example of a PCB in a wireless device including several grounded pads around the slot area. At least one electric component (such as for instance a surface mounted device, SMD) may connect two pads, one of those pads placed on one side

and the other on the other side. The component can be generally any electric component, but preferably is chosen from the examples described in embodiments one through five (for instance resistor, a short circuit element, a capacitor, an inductor, a filter, a diode, a transistor, a switch or other kind of radio frequency devices). The electric component or components can be flexibly mounted in any of the pre-fixed pads until the desired frequency response and radiation characteristics of the wireless device are obtained. Some additional feeding pads for an antenna device may be provided (for instance a short and a feeding pad for a PIFA antenna are shown in figure 5 without any limiting purpose).

Embodiment 7

In other embodiments, more than one component is connected to the slot. For instance, those components can be connected in a serial or cascading connection and / or, in parallel, through a pair or multiple pads. This applies to any of the components mentioned above, in particular to the components of the above described embodiments.

Embodiment 8

In this embodiment, which can be combined with any of the above embodiments, the slot in the ground-plane is coupled to an antenna device. Although the antenna can be any type of antenna (a monopole, a dipole, a patch, a dielectric antenna or alike), usually a patch antenna, and more specifically a planar inverted F antenna (PIFA) will be preferred. Although the slot can be placed generally in any place of the PCB, preferably it will be placed substantially close to the antenna element such that the electromagnetic coupling between slot and antenna element is enhanced. In a preferred embodiment the slot will be placed under the antenna. In another embodiment, the slot will be placed substantially aligned with at least one of the edges of the antenna. A reconfigurable wireless device with a reconfigurable antenna+ground-plane set is obtained by placing one or more pads close to the edge of such at least one slot.

The attached drawings comprise the following figures:

- Fig. 1 shows a member 1 for a wireless device;
- Fig. 2 shows the combination of the member for a wireless device and an electric component;
- Fig. 3 shows different configurations of slots and connecting means;
- Fig. 4 shows a preferred embodiment of the member for a wireless device;
- Fig 5. shows a PCB and a reconfigurable slot (Embodiment 6). The PCB can be tested with the component placed in the several positions to decide which is the optimum position for the desired radio frequency response;
- Fig. 6 shows a PCB of a wireless device and a reconfigurable slot (Embodiment 7). In this particular example, two SMD components are cascaded to interconnect two pads at opposite edges of the slot. For instance this can be an inductor and a capacitor, to make a serial LC filter or resonator;
- Fig. 7 shows a PCB of a wireless device and a reconfigurable slot (Embodiment 7). In this particular example, two SMD components are mounted in parallel to interconnect the two opposite edges of the slot. For instance this can be an inductor and a capacitor, to make a shunt LC filter or resonator;
- Fig.8 shows a reconfigurable slot in a ground-plane coupled to a PIFA antenna device;
- Fig. 9a shows a reconfigurable slot in a ground-plane coupled to a PIFA antenna device. Short and feeding pads of the antenna are placed at opposite sides of the slot;
- Fig. 9b shows the reconfigurable slot in a ground-plane in particular useful for cases without a separate antenna element, where the slot acts as an antenna;
- Fig. 10 shows a wireless device (here a mobile telephone) in combination with a member for a wireless device.

Fig. 1a shows in a three dimensional schematic diagram a part of a member 1 for a wireless device. The member 1 comprises two conducting layers 2, 3 which form two conducting portions of the ground plane. Those two portions are separated by a slot 6 where no conducting layer is provided. The conducting layers 2, 3 are provided on a PCB board 7.

On the two sides of the slot 6, contact pads 4, 5 are provided. They are in such an opposite relation that they can be interconnected with an electric component which is oriented essentially perpendicular to the slot 6 at the location between the two connecting means 4, 5. A cut section along line bb of Fig. 1a is shown in Fig. 1b. On the circuit board substrate 7, which may be a conventional circuit board, two conducting layers 2, 3 are provided which are separated by a slot 6. Those conducting layers 2, 3 are each covered partially by an insulating material 8, 9, respectively. The insulating materials 8, 9 do not cover entirely the portions 2, 3 and some part of the portions 2, 3 are left blank. Those parts are one example of the contact pads 4, 5 as shown in Fig. 1a.

The outer shape of the member 1 is not shown in Fig. 1a since the outer shape may essentially be any shape. It may be rectangular, circular, elliptic, irregularly shaped or any other shape. Usually it will be adapted to the shape of the wireless device.

Fig. 2 shows the member 1 of Fig. 1 where an electric component 10 is added. As can be seen in Fig. 2a and Fig. 2b, this component bridges the slot 6 and is connected to the two pads 4, 5 thereby connecting the two ground plane portions 2, 3. The electric connection between each pad and the electric component may be established by solder.

In Fig. 1 and 2, the two pads 4, 5 are provided on the edge of the slot 6. However, some insulating material may also be provided directly at the edge of the slot 6 such that the contact pads 4, 5 are provided at a certain distance from the slot 6. However they should not be further away from the slot 6 than e.g. the size of the pad 4, 5 or of the slot in a direction perpendicular to the slot 6. When providing the slot with connecting means at both sides, the manufacturing process itself may impose

manufacturing tolerances that may not make possible and/or convenient to arrange them closer than a certain distance d .

Fig. 3 shows schematic views of alternative formations of the slot.

In Fig. 3a, the slot 6 is shown which only partially penetrates into the ground plane. The portion 12 of the ground plane is provided which connects the portions 2 and 3 which are separated by the slot 6.

In Fig. 3a, at least one end of the slot 6 coincides with the end of the ground plane 2, 3 (see Fig. 3a bottom). The slot depicted in Fig. 3a features an open end and a closed end. The slot may also be provided entirely within the ground plane which means that the slot is surrounded by the ground plane at all ends of the slot, and therefore the slot 6 has at least two closed ends.

In Fig. 3b it is shown that the slot is not necessarily straight but may also be bent or curved.

In Fig. 3c, it is shown that the width of the slot 6 may be non-uniform due to the protrudence or protrusion of one ground plane portion 3. Independent of the protrusions or the non-uniform width of the slot this Fig. also shows an example where the connecting means 4a, 4b, 4c and 5a, 5b, 5c are spaced at different spacing along the slot since e.g. connecting means 4b and 4c are closer together than 4a and 4b.

In Fig. 3d it is shown that the ground plane portions 2, 3 on both sides of the slot 6 may have protrusions. Preferably, those protrusions are opposite to each other. They may, however, also be offset along the slot 6.

The pads 4a, 4b, 4c, 5a, 5b, 5c are provided on those protrusions. In this way, the pads are provided at narrow portions of the slot 6.

In Fig. 3e, the case is shown where the slot has a curved edge which is not composed by straight lines. Here the pads 4a, 4b, 5a, 5b are also provided at the narrow portions of the slot 6. They may, however, also be provided at wider portions of the slot 6 (the same applies to Fig. 3c and 3d).

In Fig. 3f two elongated connecting means 4,5 are shown which extend along the slot 6. They have a length of more than half of the length of the slot 6. On such connecting means the electric component(s) may be placed anywhere such that a continuous fine tuning of the electric characteristics is possible by choosing the location of the electric component freely along the length of the connecting means.

In Fig. 3g the case is shown where the two connecting means 4, 5 are given by two portions of a continuous connecting means, which are provided on two different sides of the slot 6 or gap. The connecting means 4, 5 extends around the end of the slot 6 (in Fig. 3g the upper end).

In Fig. 4, a particular case of a slot 6 is shown where at least some of the contact pads are provided in corners formed by the slot 6. As can be seen in Fig. 4, the contact pads 13 and 18 are in corners. The contact pad 16 is provided at the end of a protrusion of the ground plane portion 2. With this configuration, an electric component may be located e.g. connecting the pad 16 with the pad 13, 15 or 18. The spacing between the pad 16 relative to the pad 13, 15 and 18 is always the same such that electric components with the same size can be located at any of those possible three combinations. Also, it would be possible to connect pad 13 with pad 16 and at the same time connect pad 16 with pad 15 or 18 with another device. Pad 13 may alternatively also be connected with an electric component 20 (dashed line) with pad 14. As an example only, an electric component 19 is provided in order to connect pad 16 and pad 18.

The example of Fig. 4 shows that with 6 pads (13 to 18), 5 different possible connections between pads on different sides of slot 6 are possible. In general therefore, the pads may be arranged in such a way that one pad on one side of the slot may be connected to at least two or three other pads on the other side of the slot with identical components.

In the following figures the ground plane shapes have an outer shape of a rectangle, as an example only.

Fig. 5 shows a special case of a ground plane 2, 3 where a slot is provided with one end at one edge of the ground plane (open end) and terminates with another end within the ground plane (closed end). The two portions 2, 3 are therefore connected by a portion of the ground plane.

Portions 2, 3 each are provided with a multiple number of pads, where in Fig. 5, as an example, each side is provided with seven pads. All the pads are located on or close to the edge of the slot 6. The number of pads on both sides of the slot here is equal. The number may, however, also be different.

Between pads opposite to each other across the slot 6, an electric component 10 may be provided bridging the slot 6.

Depending on the pads which are interconnected by the component 10, the slot in the ground plane and thus the slotted ground plane will have different electric characteristics. As explained above, by connecting different pads on each side of the slot 6, different electric characteristics can be achieved.

On one portion 2 of the ground plane, a short connection (pad) 21 and a feeding connection (pad) 22 is provided. The feeding connection is provided for connecting the antenna radiating element to a high frequency generator/receiver and the grounding connection (pad) is provided in order to ground a portion of the antenna radiating element with the ground plane. This may be useful for IFA or PIFA antennas. The position of the connections 21 and 22 may be interchanged. Further they may be positioned closer to or in the middle of the upper end of the ground plane portion 2 or closer to the opposite upper end (upper left corner in Fig. 5).

In Fig. 6, a case is shown where two electric components 10a, 10b are connected in series in order to connect two pads 4, 5 each of which is provided on a portion 2, 3 of the ground plane.

In Fig. 7, the case is shown where two electric components 10a, 10b are provided in parallel in order to connect the two portions 2, 3 of the ground plane across the slot 6.

In Fig. 8a the configuration of the ground plane in combination with an antenna is shown.

The antenna element 26 is provided at a certain distance from the ground plane 2, 3. Further, the antenna element 26 is provided close to an edge of the ground plane. The slot 6 is provided close to the same edge. In this way, the antenna element and the slot 6 are close together which allows for a good electromagnetic coupling.

The antenna element 26 is connected with one terminal 24 to one portion 3 and with another terminal 25 to another portion 2 of the ground plane. The terminal 24 is connected to the feeding pad 23 and the other terminal 25 is grounded to the ground plane.

The slot 6 of the ground plane may act as an antenna. This slot antenna and the antenna element 26 may both be excited by the same feeding connection 23.

As shown in Fig. 8b additionally a number of connecting means 4a, 4b, 4c, 5a, 5b, 5c (connecting pads) are provided so that the radiating characteristics of the slot can be adjusted.

The views in the middle and on the right hand side of Fig. 8a and 8b show a view perpendicular onto the ground plane and the slot 6. The antenna element 26 is located in front of that slot 6. The lines covered by the antenna element 26 are shown in dashed lines. Further the location of the connecting means (grounded pads) 4, 5 are shown. The antenna element 26 and the connecting means 4, 5 are provided on the same side (before/behind) of the ground plane.

In general, however, the connecting means 4, 5 and the antenna element 26 may be provided on opposite sides (before/behind) of the ground plane 2, 3.

In Fig. 9a, the case is shown where the feeding connection 22 and the ground connection 21 are provided on different sides of the slot 6. This means that they are provided on different portions 2, 3 of the ground plane. In this case the slot may be the antenna itself. No additional radiating element may be required. Nevertheless a further antenna element may be provided in order to have further operating frequencies

available or to improve the radiation characteristics of the combination of the slot and the antenna element.

As shown in Fig. 9b the feeding connection 22 and/or the ground connection 21 can be placed between connecting means 4, 5 in a direction along the slot. This arrangement can be in particular useful, when no separate antenna element is provided and the slot 6 acts as an antenna. As shown in the arrangement in Fig. 9a the feeding connection 22 and/or ground connection 21 may nevertheless also be provided on one side (in a direction along the slot) of the connecting means 4, 5 only.

In general the feeding connection 22 and/or the ground connection 21 may be placed close to an end of the slot (in particular a closed end), at the middle of the slot or spaced from the end of a slot by a third or fourth part of the length of the slot along the slot or within any interval of those values.

As shown in Fig. 8 and 9 the feeding connection 22, 23 is preferably placed on the portion 3 of the ground plane that is larger than the other portion 2, since on this larger portion the frequency generator/receiver (not shown) may be placed conveniently and may such be placed very close to the feeding connection 22, 23. The feeding connection 22, 23 and/or the ground connection may nevertheless also be provided on the other portion 2, 3 in comparison to Fig. 8 and 9.

In any of the above shown examples, the slot 6 itself may function as an antenna. The slot has a characteristic length which allows the slot to resonate at a resonance frequency. Therefore it is not always necessary that a separate antenna element is provided.

In Fig. 10, a mobile phone (also called a cellular phone) 30 is shown. Within that cellular telephone, which here represents any wireless device, a member with two ground plane portions 2, 3, a slot 6 and an electric component 10 bridging the slot 6 is shown.

In a preferred arrangement, the antenna is a PIFA antenna, with one short (direct electric contact between the antenna element and the ground plane) at one edge of the slot and the feeding point at the opposite edge. This enables a combined excitation

of both the slot and the antenna, such that a broadband, multiband or combination of both effects is obtained. Such an arrangement becomes also useful to match the impedance of the antenna at one or more frequency bands.

In some embodiments, the slot can be excited with one or more spring contacts or metallic bridges crossing over the slot, which means, that the a spring contact is used to establish an electric connection through which feeding is carried out. By placing several pads at opposite sides of the slot according to the present invention, an adjustment of the optimum slot excitation can be obtained without changing the layout of the PCB.

Generally, the present invention can be arranged inside several kinds of wireless devices to enhance its radiation characteristics. A multiband, multi systems device with enhanced performance (bandwidth, number of bands, radiation efficiency, sensitivity, gain) is obtained. In some preferred embodiments the wireless device is operating at one, two, three or more of the following communication and connectivity services: GSM850, GSM900, GSM1800, PCS1900, GSM450, UMTS, WCDMA, CDMA, Bluetooth, WLAN, WiFi, UWB, ZigBee, GPS, Galileo, SDARs, XDARS, WiMAX.

It should be stressed that the slot does not necessarily need to have a linear shape with a constant width. Other forms such as space-filling curves as described in the PCT publication WO 0154225, fractal, or multilevel structures as described in the PCT publication WO 0122528 are possible within this invention. Non-uniform width slots are possible as well. In the case of non-uniform width slots, the component or components will be preferably placed in those regions where the distance between opposite edges of the slot is minimum.

The ground-plane can feature generally any shape, such as a space-filling (see for instance WO 0154225), a multilevel (see for instance WO 0122528), a polygonal, conformal or fractal shape.

While the invention has been described with respect to specific examples including presently preferred modes of carrying out the invention, those skilled in the art will appreciate that there are numerous variations and permutations of the above

described systems and techniques that fall within the spirit and scope of the invention as set forth in the appended claims.

CLAIMS

1. Member (1) for a wireless device,

wherein that member (1) is or comprises a ground-plane (2, 3) with at least two portions (2, 3),

wherein on each of said portions (2, 3) at least one connecting means such as a pad (4, 5) is provided,

wherein the two connecting means (4, 5) can be connected with an electric component (10) for connecting said two portions (2, 3) of said ground plane.

2. Member according to claim 1, wherein said two portions (2, 3) are connected by a third portion (12) of the ground plane itself or are not connected by any portion of the ground plane.

3. Member according to any of claims 1 or 2, wherein a slot (6) is provided in that ground plane such that said two portions (2, 3) are on different sides of the slot (6).

4. Member according to claim 3, wherein the connecting means (4, 5) are provided around the edges of said slot (6).

5. Member according to any of claims 1 to 4, wherein at least one of said portions (2, 3) or both portions (2, 3) have at least two, three, four, five, seven, ten, fifteen, twenty, thirty, forty or fifty or more connecting means (4, 4a, 4b, 4c, 5, 5a, 5b, 5c).

6. Member according to any of claims 1 to 5, wherein said ground plane (2, 3) has at least one, two, three or more connecting means (21, 22) for connections to one or more feeding and/or one or more radiating elements (26).

7. Member according to any of claims 1 to 6, wherein said ground-plane (2, 3) is partially covered with an insulating material (8, 9) and said connecting means (4, 5) are given by a part of the ground-plane which is not covered by any insulating material (8, 9).

8. Member according to claim 7, wherein said insulating material (8, 9) separates different parts of the ground plane giving the connecting means (4a, 4b, 4c, 5a, 5b, 5c) on each portion (2, 3).

9. Member according to any of claims 1 to 8, wherein said at least two connecting means (4, 5) are connected by an electric component (10) which is one of the group of electric components comprising a resistor, a short circuit element, a capacitor, an inductor, a filter, a diode, a transistor, a switch, a radio frequency device.

10. Member according to any of claims 1 to 9, wherein two, three or more electric components (10, 10a, 10b) are provided for connecting said two portions and/or any additional portion/portions of the ground plane which are selected from the group of electric components comprising a resistor, a short circuit element, a capacitor, an inductor, a filter, a diode, a transistor, a switch, a radio frequency device, wherein at least some of the electric components or all are the same and/or different.

11. Member according to any of claims 1 to 10, wherein said ground plane is coupled with one or more antenna elements (26).

12. Member according to claim 11, wherein said antenna element (26) is an IFA, preferably a PIFA antenna, a patch antenna, a monopole antenna, a dipole antenna, or a dielectric antenna.

13. Member according to any of claims 11 or 12, wherein a feeding terminal (24) and a shorting terminal (25) of said antenna element (26) are provided on the same or on different portions (2, 3) of said ground plane.

14. Member according to any of claims 1 to 13, wherein said member (1) comprises a circuit board (7) on and/or in which the ground-plane (2, 3) is provided as a conductive layer, such as a metal layer.

15. Member according to any of claims 1 to 14, wherein said electric component (10) comprises or is a surface mount device and/or a bonding wire.

16. Wireless device (30) comprising a member (1) according to any of claims 1 to 15.

17. Wireless device (30) including a ground plane (2, 3) with at least two portions (2, 3)

wherein said two portions (2, 3) are connected by an electric component (10), wherein the connection is preferably made between two portions (2, 3) of the ground-plane which are separated by a gap or a slot in the conducting surface of said ground-plane.

18. Wireless device (30) according to claim 17, wherein the connection is made between connecting means (4, 5) provided at two portions (2, 3) of the ground plane.

19. Wireless device (30) that includes at least one ground plane (2, 3),

said ground plane (2, 3) includes at least one slot (6), wherein the device (30) comprises one or more electric components (10, 10a, 10b, 19, 20) interconnecting opposite sides of said slot (6).

20. Wireless device according to any of claims 17 to 19, wherein one, two, three, four, five, seven, ten, fifteen, twenty, thirty, forty or fifty or more connecting means such as pads (4, 5) are provided on said ground plane around the edges of said slot (6).

21. Wireless device according to claim 20, wherein said one or more electric components (10, 10a, 10b, 19, 20) are connected to said connecting means (4,5).

22. Wireless device according to any of claims 17 to 21, wherein such an electric component (10, 10a, 10b, 19, 20) or components (10, 10a, 10b, 19, 20) are selected from the group of components including a short circuit element, a resistor, a capacitor, an inductor, a filter, a switch, a diode, a transistor.

23. Wireless device according to any of claims 17 to 22, wherein the wireless device (30) further comprises a radiating antenna element coupled to said slot (6).

24. Wireless device according to claim 23, wherein said antenna element is an IFA, preferably a PIFA antenna, a patch antenna, a monopole antenna, a dipole antenna, a dielectric antenna.

25. Wireless device according to claim 24, wherein a feeding and a shorting terminal of said IFA antenna are placed at opposite sides of the slot (6).

26. Wireless device according to any of claims 17 to 25, wherein the wireless device is at least one or a combination of wireless devices of a group of wireless devices comprising a cellular phone, a mobile phone, a handheld phone, a smart phone, a satellite phone, a multimedia terminal, personal digital assistant (PDA), a portable music player, a radio, a digital camera, a USB dongle, a wireless headset, an ear phone, a hands-free kit, an electronic game, a remote control, an electric switch, a light switch, an alarm, a car kit, a computer card, a PCMCIA card, a sensor, a headset, a dongle, a computer interface a computer mouse, a keyboard, a personal computer, a MP3 player, a portable DVD/CD player, a smoke detector, a switch, a motion sensor, a pressure sensor, a temperature sensor, a medical sensor, a meter, a short/medium range wireless connectivity application, a Mini-PCI, a Notebook, PC with WiFi module integrated, a compact flash wireless card, a UART dongle, a pocket PC with integrated Wi-Fi, an access point for a hot spot, a wireless wrist watch, a wireless wrist sensor, a bracelet FM radio, an MP3 player, a radio frequency identification tag, key remote entry system, an air pressure sensor e.g. in a tires, a radio controlled toy, and a carbus 32 card.

27. Wireless device according to any of claims 17 to 26, wherein said device is configured to operate at one or more wireless communication systems preferably selected from the group comprising Bluetooth, 2.4GHz Bluetooth, 2.4 GHz WiMAX, ZigBee, ZigBee at 860 MHz, ZigBee at 915 MHz, GPS, GPS at 1.575 GHz, GPS at 1.227 GHz, Galileo, GSM 450, GSM 850, GSM 900, GSM 1800, DCS-1800, UMTS, CDMA, DBA, WLAN, WLAN at 2.4 GHz-6GHz, PCS 1900, KPCS, WCDMA, SDARS, XDARS, DAB, WiFi, UWB, 2.4-2.483 GHz band, and 2.471-2.497 GHz band.

1/6

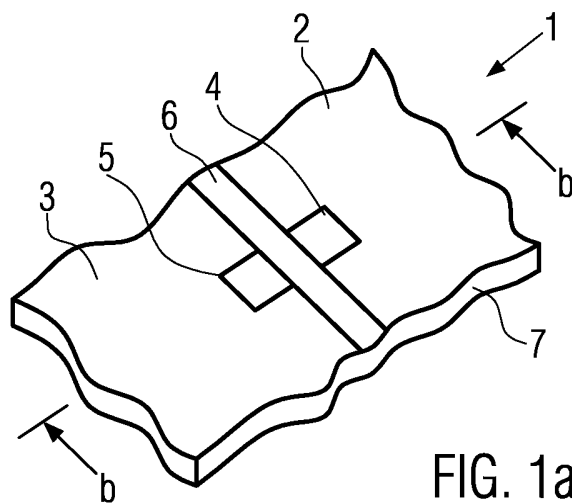

FIG. 1a

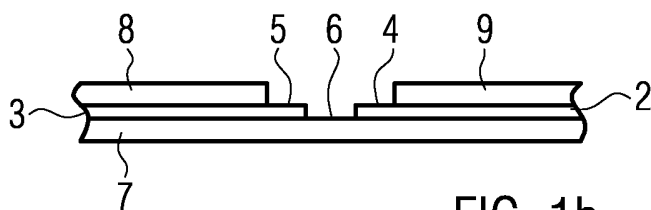

FIG. 1b

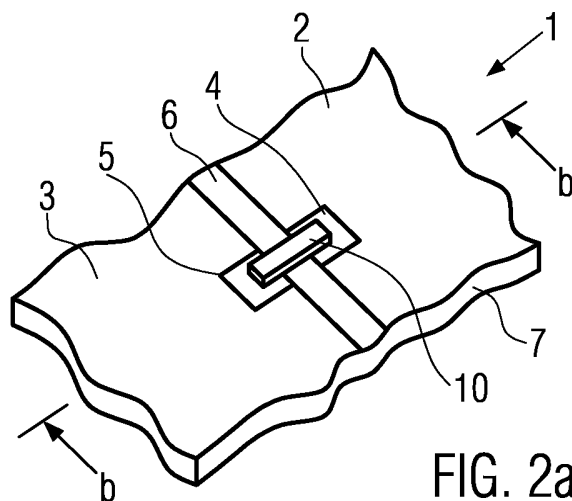

FIG. 2a

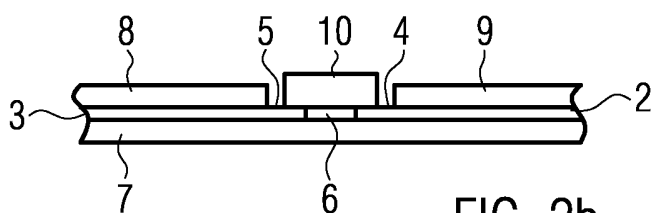

FIG. 2b

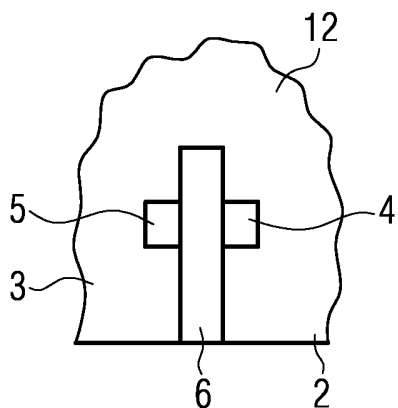

FIG. 3a

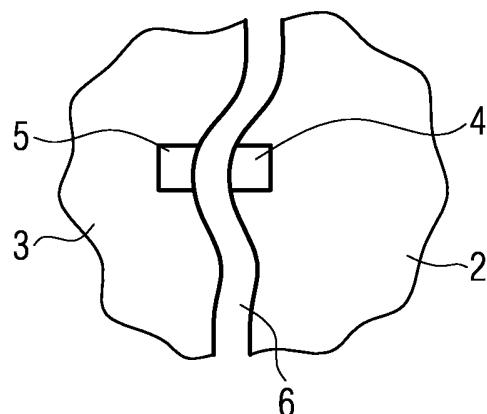

FIG. 3b

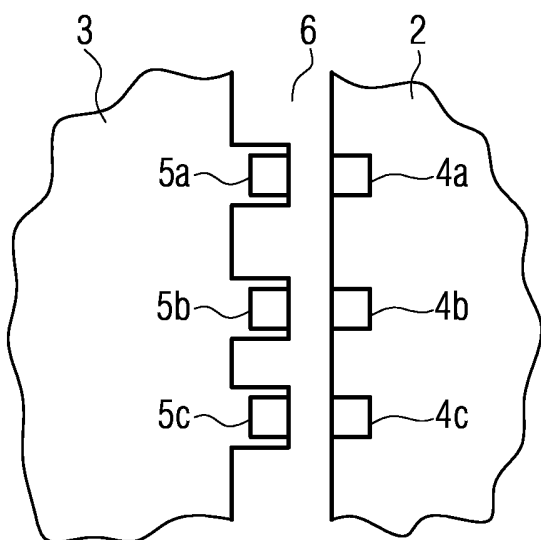

FIG. 3c

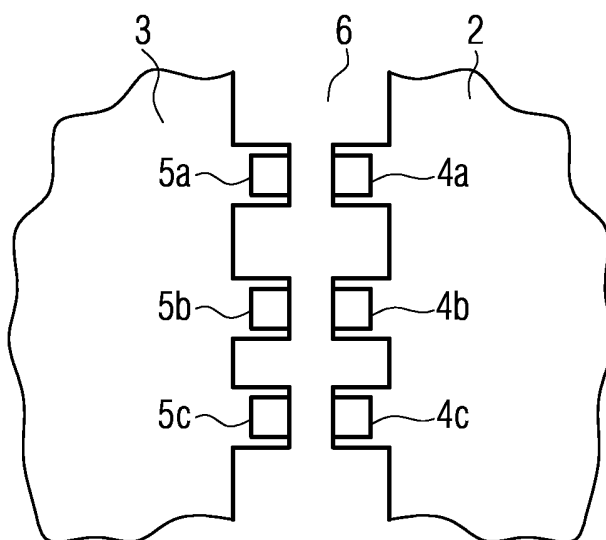

FIG. 3d

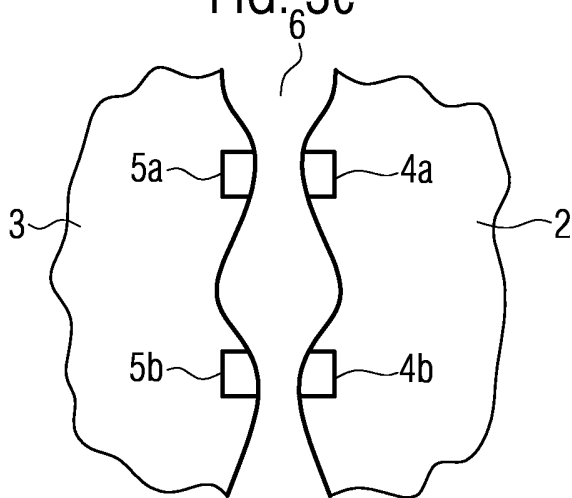

FIG. 3e

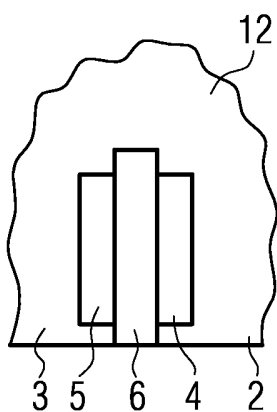

FIG. 3f

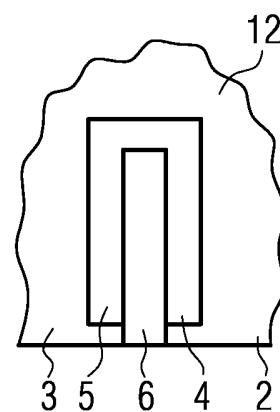

FIG. 3g

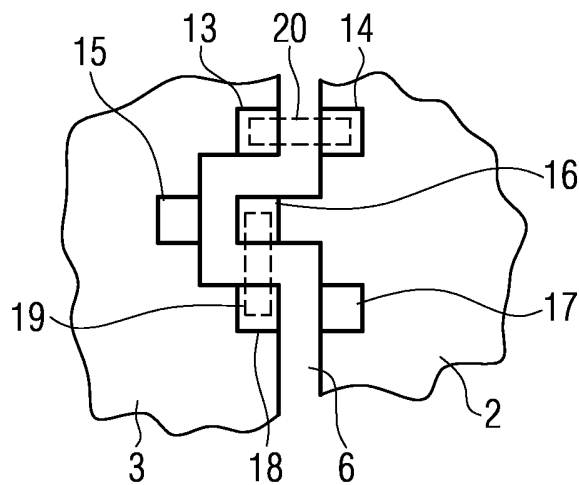

FIG. 4

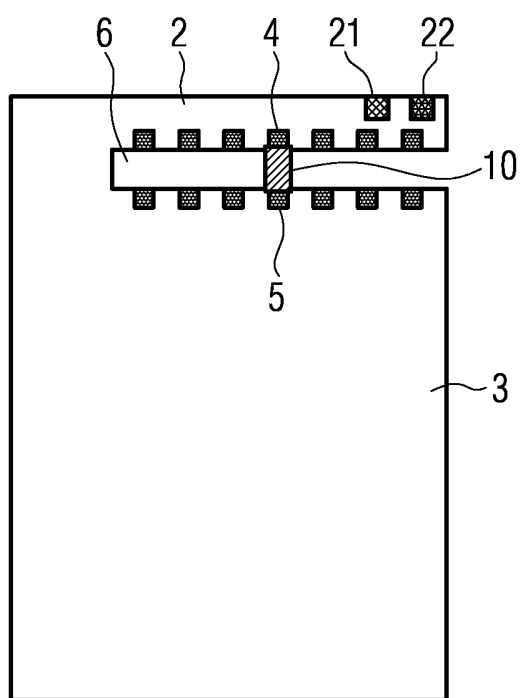

FIG. 5

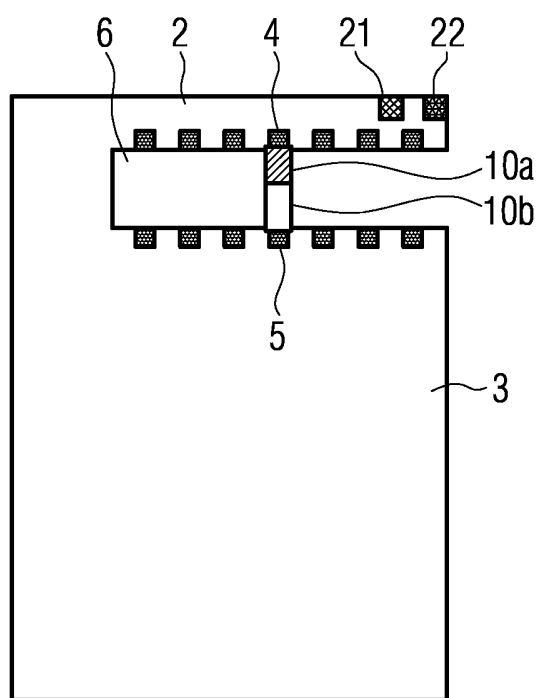

FIG. 6

4/6

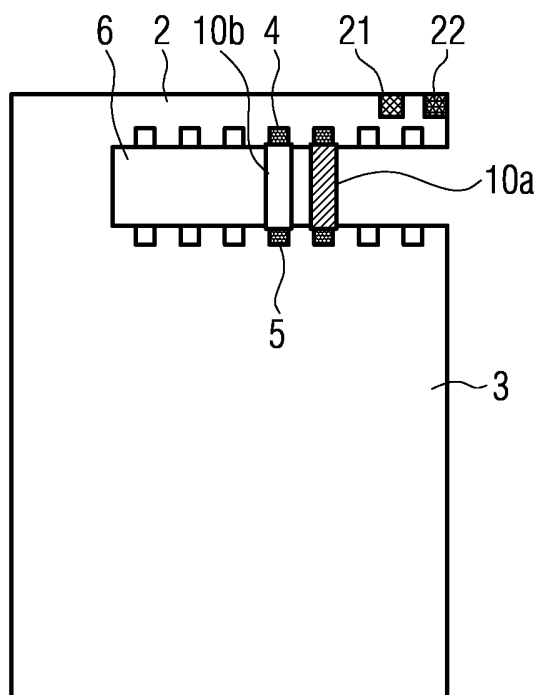

FIG. 7

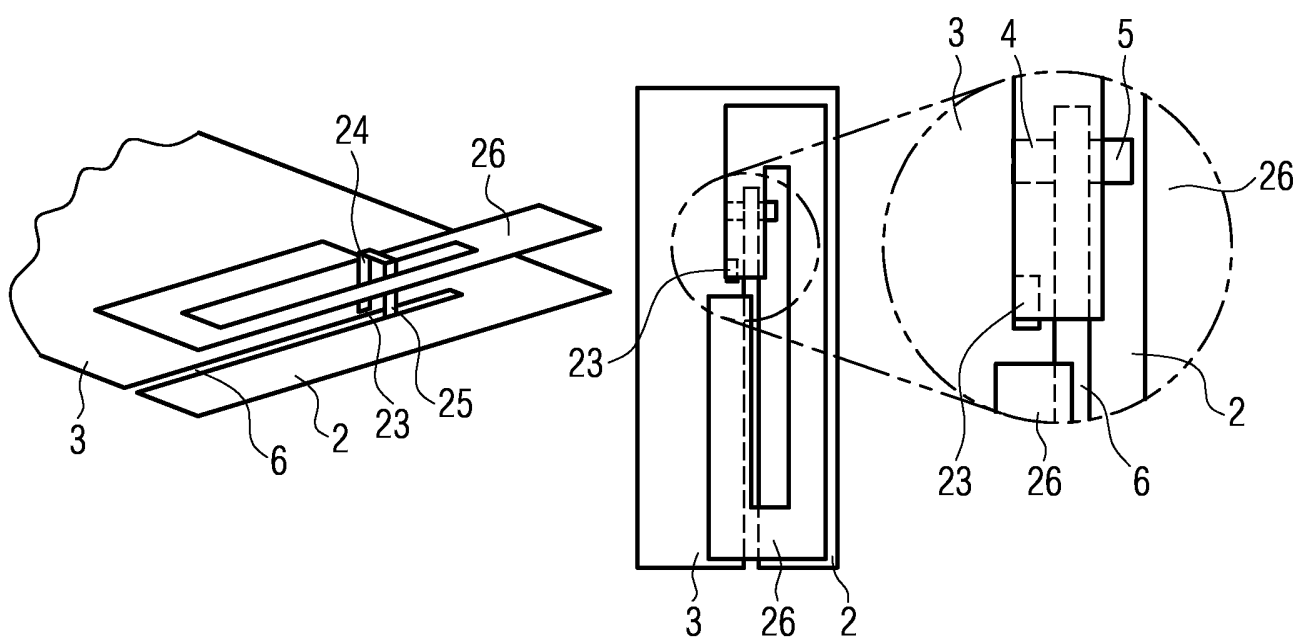

FIG. 8a

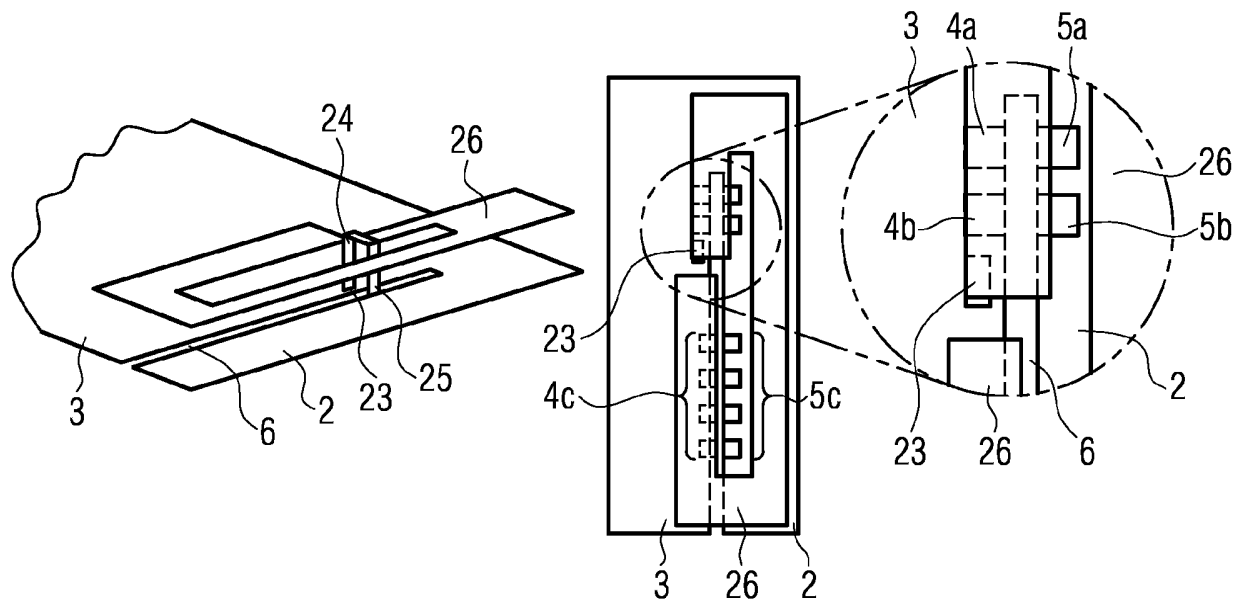

FIG. 8b

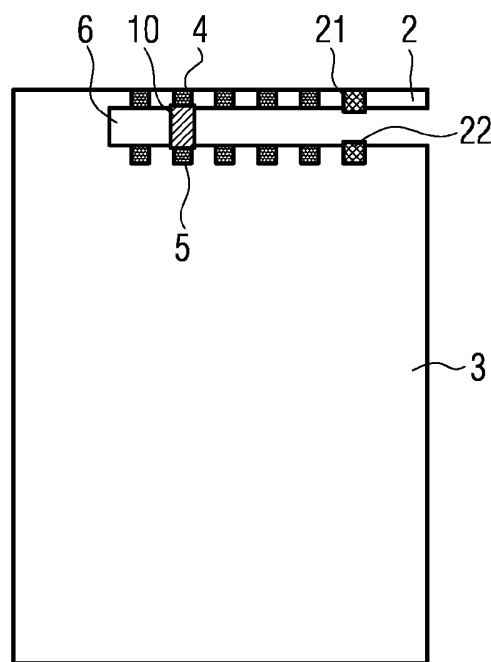

FIG. 9a

6/6

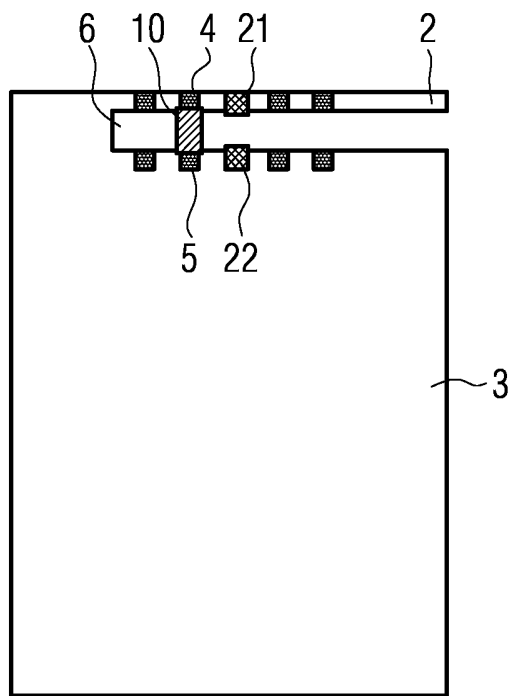

FIG. 9b

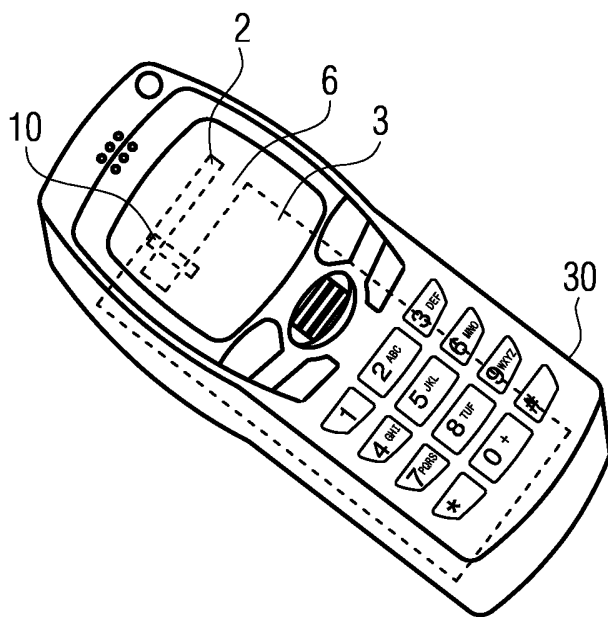

FIG. 10

INTERNATIONAL SEARCH REPORT

International application No
PCT/EP2006/060766

A. CLASSIFICATION OF SUBJECT MATTER

INV. H01Q1/38
ADD. H01Q13/10 H01Q9/04

According to International Patent Classification (IPC) or to both national classification and IPC

B. FIELDS SEARCHED

Minimum documentation searched (classification system followed by classification symbols)
H01Q

Documentation searched other than minimum documentation to the extent that such documents are included in the fields searched

Electronic data base consulted during the international search (name of data base and, where practical, search terms used)

EPO-Internal, PAJ

C. DOCUMENTS CONSIDERED TO BE RELEVANT

Category*	Citation of document, with indication, where appropriate, of the relevant passages	Relevant to claim No.
E	WO 2006/031170 A (AMC CENTURION AB; RUTFORS, TOMAS; VON ARBIN, AXEL) 23 March 2006 (2006-03-23) abstract; figure 1	1-5, 9, 12, 13, 16-20, 22, 24-27
X	WO 2004/102744 A (KONINKLIJKE PHILIPS ELECTRONICS N.V; BOYLE, KEVIN, R) 25 November 2004 (2004-11-25) abstract; figures 2,6	1-5, 7-13, 16-20, 22-24, 26, 27
Y	US 2003/122721 A1 (SIEVENPIPER DANIEL F) 3 July 2003 (2003-07-03) figure 7	15
	----- -/--	

Further documents are listed in the continuation of Box C.

See patent family annex.

* Special categories of cited documents :

- *A* document defining the general state of the art which is not considered to be of particular relevance
- *E* earlier document but published on or after the international filing date
- *L* document which may throw doubts on priority claim(s) or which is cited to establish the publication date of another citation or other special reason (as specified)
- *O* document referring to an oral disclosure, use, exhibition or other means
- *P* document published prior to the international filing date but later than the priority date claimed

- *T* later document published after the international filing date or priority date and not in conflict with the application but cited to understand the principle or theory underlying the invention
- *X* document of particular relevance; the claimed invention cannot be considered novel or cannot be considered to involve an inventive step when the document is taken alone
- *Y* document of particular relevance; the claimed invention cannot be considered to involve an inventive step when the document is combined with one or more other such documents, such combination being obvious to a person skilled in the art.
- * & * document member of the same patent family

Date of the actual completion of the international search

3 July 2006

Date of mailing of the international search report

13/07/2006

Name and mailing address of the ISA/

European Patent Office, P.B. 5818 Patentlaan 2
NL - 2280 HV Rijswijk
Tel. (+31-70) 340-2040, Tx. 31 651 epo nl,
Fax: (+31-70) 340-3016

Authorized officer

Marot-Lassauzaie, J

INTERNATIONAL SEARCH REPORT

International application No
PCT/EP2006/060766

C(Continuation). DOCUMENTS CONSIDERED TO BE RELEVANT		
Category*	Citation of document, with indication, where appropriate, of the relevant passages	Relevant to claim No.
Y	US 5 268 696 A (BUCK ET AL) 7 December 1993 (1993-12-07) figure 1	15
A	----- US 5 777 581 A (LILLY ET AL) 7 July 1998 (1998-07-07) the whole document	1-27
A	----- PATENT ABSTRACTS OF JAPAN vol. 2003, no. 12, 5 December 2003 (2003-12-05) & JP 2005 012516 A (MITSUBISHI ELECTRIC CORP), 13 January 2005 (2005-01-13) abstract -----	1-27

INTERNATIONAL SEARCH REPORT

Information on patent family members

International application No PCT/EP2006/060766

Patent document cited in search report	A	Publication date	SE	Patent family member(s)	Publication date
WO 2006031170	A	23-03-2006	SE	0402182 A	14-03-2006
WO 2004102744	A	25-11-2004	EP	1625639 A1	15-02-2006
US 2003122721	A1	03-07-2003	AU	2002351307 A1	24-07-2003
			DE	10297569 T5	02-12-2004
			GB	2400240 A	06-10-2004
			JP	2005514844 T	19-05-2005
US 5268696	A	07-12-1993	NONE		
US 5777581	A	07-07-1998	US	5943016 A	24-08-1999
			US	6061025 A	09-05-2000
JP 2005012516	A	13-01-2005	NONE		