

J. IFFT.  
 METALLIC TIE AND RAIL FASTENER.  
 APPLICATION FILED MAR. 3, 1911.

994,589.

Patented June 6, 1911.

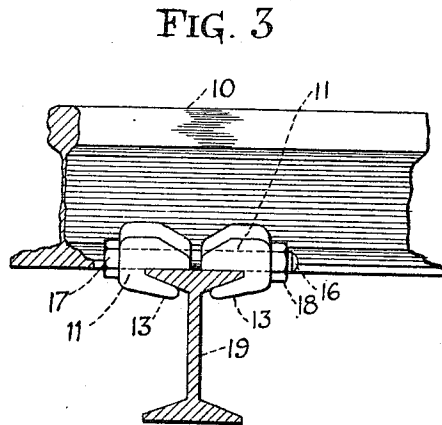
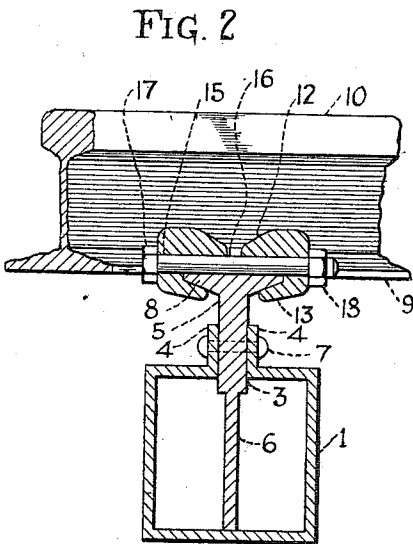
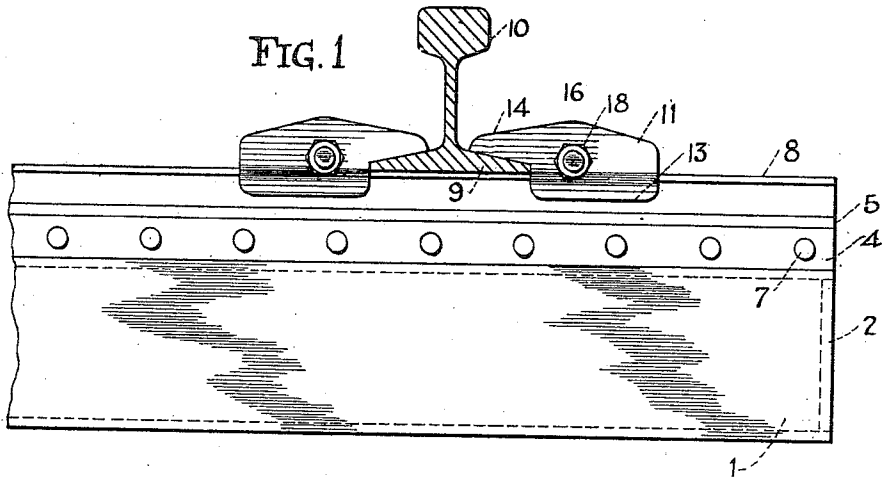

WITNESSES  
 J.R. Mahaney  
*K.N. Butler*

INVENTOR  
 John Ifft.  
 By *A.C. Ernest & Co.*  
 Attorneys.

# UNITED STATES PATENT OFFICE.

JOHN IFFT, OF ZELIENOPLE, PENNSYLVANIA.

METALLIC TIE AND RAIL-FASTENER.

994,589.

Specification of Letters Patent. Patented June 6, 1911.

Application filed March 3, 1911. Serial No. 611,971.

To all whom it may concern:

Be it known that I, JOHN IFFT, a citizen of the United States of America, residing at Zelienville, in the county of Butler and State of Pennsylvania, have invented certain new and useful Improvements in Metallic Ties and Rail-Fasteners, of which the following is a specification, reference being had therein to the accompanying drawing.

This invention relates to metallic ties and rail fasteners, and the objects of my invention are to substitute metal for wood in the ties or sleepers employed for supporting the rails of a track, and to provide metallic ties that can be easily handled, positioned and tamped in a roadbed.

Other objects of my invention are to furnish a metallic tie with a fastener that will positively retain the rails thereon and prevent lateral and vertical displacement of said rails, and to accomplish the above results by a mechanical construction that is simple, durable, and highly efficient for the purposes for which it is intended.

With the above and other objects in view the invention resides in a novel construction, combination and arrangement of parts to be hereinafter specifically described and then claimed.

Reference will now be had to the drawing, wherein:—

Figure 1 is a side elevation of a portion of the tie in accordance with this invention. Fig. 2 is a vertical cross sectional view of the same, and Fig. 3 is a cross sectional view of a modified form of the tie showing the fastener applied thereto.

A tie in accordance with this invention comprises an oblong hollow box-like structure 1 having the ends thereof closed by walls 2. The top of the structure has a central longitudinal slot 3 and the material bordering upon said slot is provided with vertical flanges 4. Arranged longitudinally of the structure 1 within the slot 3 is a web 5 having the lower edge thereof reduced, as at 6 and resting upon the bottom of the structure 1. The web 5 is secured to the flanges 4 by a plurality of equally spaced

transverse rivets 7 or other fastening means. The upper edge of the web 5 supports a longitudinal head 8 adapted to support the base flanges 9 of rails 10.

The fastener used in connection with the tie comprises two sets of clamping members 11 the members of each set being oppositely disposed. Each member has a portion 12 extending over the head 8 and a portion 13 extending under said head, besides extensions 14 extending over the base flanges 9 of the rails 10. The members of each set are provided with alining openings 15 and in these openings is mounted a bolt 16 having a head 17 engaging the outer side of one of said members and the opposite end provided with a nut 18 engaging the other of said members.

In Fig. 3 of the drawing there is illustrated a modified form of tie, which is of the I beam construction, the tie being designated 19 and provided with the fasteners to retain a rail upon the tie.

From the foregoing it will be observed that the fasteners, when released, can be shifted longitudinally of the tie and clamped in any desired position, consequently the gage of a track can be easily regulated. The tie can be easily rolled from sheet metal and the web quickly placed in position.

I reserve the right to make the tie of various sizes and of strong and durable metal.

What I claim is:—

In a metallic tie and rail fastener, an oblong box-like structure provided with a longitudinal slot in the top thereof and with end walls closing the ends of said structure, a web mounted in the slot of said structure and having the lower edges thereof resting upon the bottom of said structure, and a head carried by said web and adapted to support the rails.

In testimony whereof I affix my signature in the presence of two witnesses.

JOHN IFFT.

Witnesses:

FRED ZEHNER,  
JOHN DINSBERGER.