

(19) World Intellectual Property Organization  
International Bureau



(43) International Publication Date  
27 November 2003 (27.11.2003)

PCT

(10) International Publication Number  
**WO 03/098732 A1**

- (51) International Patent Classification<sup>7</sup>: **H01P 1/12**
- (21) International Application Number: PCT/US03/15479
- (22) International Filing Date: 14 May 2003 (14.05.2003)
- (25) Filing Language: English
- (26) Publication Language: English
- (30) Priority Data:  
60/381,099 15 May 2002 (15.05.2002) US
- (71) Applicant (for all designated States except US): **HRL LABORATORIES, LLC** [US/US]; 3011 Malibu Canyon Road, Malibu, CA 90265-4799 (US).
- (72) Inventor; and
- (75) Inventor/Applicant (for US only): **SIEVENPIPER, Daniel, F.** [US/US]; 11300 Exposition Blvd. #215, Los Angeles, CA 90064 (US).
- (74) Agents: **BERG, Richard, P.** et al.; LADAS & PARRY, 5670 Wilshire Boulevard, Suite 2100, Los Angeles, CA 90036-5679 (US).
- (81) Designated States (national): AE, AG, AL, AM, AT, AU, AZ, BA, BB, BG, BR, BY, BZ, CA, CH, CN, CO, CR, CU, CZ, DE, DK, DM, DZ, EC, EE, ES, FI, GB, GD, GE, GH, GM, HR, HU, ID, IL, IN, IS, JP, KE, KG, KP, KR, KZ, LC, LK, LR, LS, LT, LU, LV, MA, MD, MG, MK, MN, MW, MX, MZ, NI, NO, NZ, OM, PH, PL, PT, RO, RU, SC, SD, SE, SG, SK, SL, TJ, TM, TN, TR, TT, TZ, UA, UG, US, UZ, VC, VN, YU, ZA, ZM, ZW.
- (84) Designated States (regional): ARIPO patent (GH, GM, KE, LS, MW, MZ, SD, SL, SZ, TZ, UG, ZM, ZW), Eurasian patent (AM, AZ, BY, KG, KZ, MD, RU, TJ, TM), European patent (AT, BE, BG, CH, CY, CZ, DE, DK, EE, ES, FI, FR, GB, GR, HU, IE, IT, LU, MC, NL, PT, RO, SE, SI, SK, TR), OAPI patent (BF, BJ, CF, CG, CI, CM, GA, GN, GQ, GW, ML, MR, NE, SN, TD, TG).

[Continued on next page]

(54) Title: A SWITCH ARRANGEMENT AND METHOD OF MAKING SAME

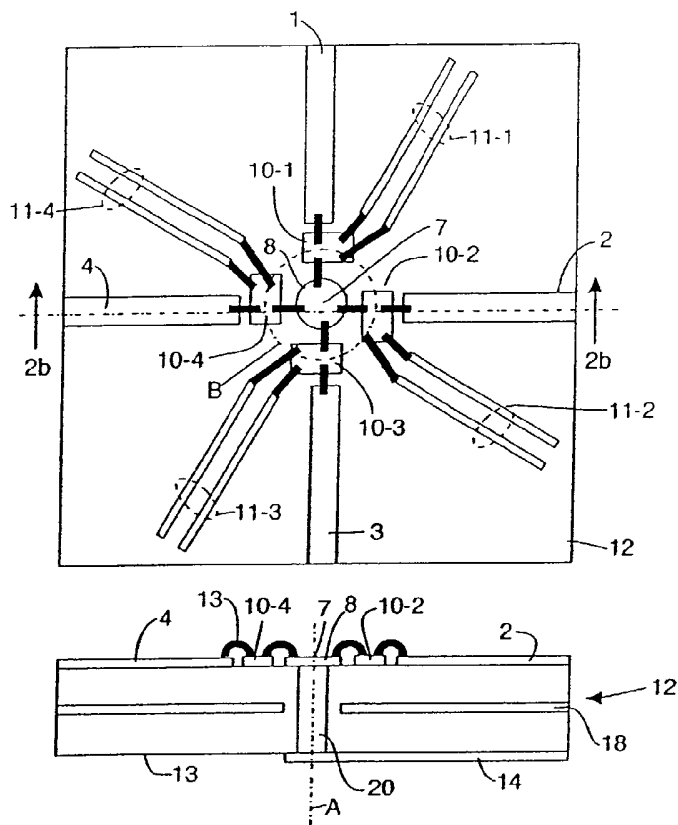

(57) Abstract: A switch arrangement comprises a plurality of MEMS switches arranged on a substrate about a central point, each MEMS switch being disposed on a common imaginary circle centered on the central point. Additionally, and each MEMS switch is preferably spaced equidistantly along the circumference of the imaginary circle. Connections are provided for connecting a RF port of each one of the MEMS switches with the central point.



WO 03/098732 A1



**Published:**

— *with international search report*

*For two-letter codes and other abbreviations, refer to the "Guidance Notes on Codes and Abbreviations" appearing at the beginning of each regular issue of the PCT Gazette.*

## A Switch Arrangement and Method of Making Same

### Cross reference to Related Applications

This application claims the benefit of US Provisional Patent Application 60/381,099 filed on May 15, 2002, which application is incorporated herein by reference.

### 5 Technical Field

The present disclosure relates to single-pole, multi-throw switches that are built using single-pole, single-throw devices combined in a hybrid circuit. The switches of this invention are symmetrically located around a central point which is a vertical via in a multi layer printed  
10 circuit board. The present disclosure describes a single-pole multi-throw switch having low parasitic reactance, and an antenna incorporating the same.

### Background

15 This application incorporates by reference the disclosure of US Provisional Patent Application Serial Number \_\_\_\_\_ filed \_\_\_\_\_ and entitled "RF MEMS Switch with Integrated Impedance Matching Structure" (attorney docket 620650-7).

In one aspect, this invention addresses several problems with existing single-pole, multi-throw  
20 switches built using single-pole, single-throw devices preferably combined in a switch matrix. According to this aspect of the invention, the switches are symmetrically located around a central point which is preferably a vertical via in a multi layer printed circuit board. In this way, a maximum number of switches can be located around the common port with a minimum amount of separation. This leads to the lowest possible parasitic reactance, and gives the circuit  
5 the greatest possible frequency response. Furthermore, any residual parasitic reactance can be

matched by a single element on the common port, so that all ports will have the same frequency response. This patent describes a 1x4 switch, but the concept may be extended to a 1x6 switch or to a 1x8 switch or a switch with even greater fan out (1xN). Also, such a switch can be integrated with an antenna array for the purpose of producing a switched beam diversity  
5 antenna.

The switch arrangement disclosed herein can be conveniently used with a Vivaldi Cloverleaf Antenna to determine which antenna of the Vivaldi Cloverleaf Antenna is active. U.S. patent application serial number 09/525,832 entitled "Vivaldi Cloverleaf Antenna" filed March 12,  
10 2000, the disclosure of which is hereby incorporated herein by this reference, teaches how Vivaldi Cloverleaf Antennas may be made.

The present invention has a number of possible applications and uses. As a basic building block in any communication system, and in microwave systems in general, a single-pole, multi-throw  
15 radio frequency switch has numerous applications. As communication systems get increasingly complicated, and they require diversity antennas, reconfigurable receivers, and space time processing, the need for more sophisticated radio frequency components will grow. These advanced communications systems will need single-pole multi-throw switches having low parasitic reactance. Such switches will be used, for example, in connection with the antenna  
20 systems of these communication systems.

The prior art includes the following:

(1) M. Ando, "Polyhedral Shaped Redundant Coaxial Switch", US Patent No. 6,252,473  
25 issued June 26, 2001 and assigned to Hughes Electronics Corporation. This patent describes a waveguide switch using bulk mechanical actuators.

(2) B. Mayer, "Microwave Switch with Grooves for Isolation of the Passages", US

Patent No. 6,218,912 issued April 17, 2001 and assigned to Robert Bosch GmbH. This patent describes a waveguide switch with a mechanical rotor structure.

Neither of the patents noted above address issues that are particular to the needs of a single-  
5 pole multi-throw switch of the type disclosed herein. Although they are of a radial design, they  
are built using a conventional waveguide rather than (i) MEM devices and (ii) microstrips. It is  
not obvious that a radial design could be used for a MEM device switch and/or a microstrip  
switch because the necessary vertical through-ground vias are not commonly used in microstrip  
circuits. Furthermore, the numerous examples of microstrip switches available in the  
10 commercial marketplace do not directly apply to this invention because they typically use PIN  
diodes or FET switches, which carry certain requirements for the biasing circuit that dictate the  
geometry and which are not convenient for use in a radial design.

There is a need for single-pole, multi-throw switches as a general building block for radio  
15 frequency communication systems. One means of providing such devices that have the  
performance required for modern Radio Frequency (RF) systems is to use RF Micro Electro-  
Mechanical System (MEMS) switches. One solution to this problem would be to simply build a  
1xN monolithic MEMS switch on a single substrate. However, there may be situations in which  
this is not possible, or when one cannot achieve the required characteristics in a monolithic  
20 solution, such as a large fan-out number for example. In these situations, a hybrid approach  
should be used.

There are numerous ways to assemble single-pole, single-throw RF MEMS switches on a  
microwave substrate, along with RF lines to create the desired switching circuit. Possibly the  
25 most convenient way is shown in Figure 1. A common port, represented here as a microstrip  
line 5, ends at a point 6 near which several RF MEMS switches 10-1 through 10-4 are  
clustered. RF MEMS switches 10-1 through 10-4 are preferably spaced equidistantly from a  
centerline of microstrip 5 and laterally on each side of it. Ports 1, 2, 3, and 4 then spread out

from this central point 6, with each port being addressed by a single MEMS switch 10. The substrate, of which only a portion is shown, is represented by element 12. By closing one of the switches (for example, switch 10-4), and opening all of the others (for example, switches 10-1 through 10-3), RF energy can be directed from the common port provided by microstrip line 5 to the chosen selectable port (port 4 in this example) with very low loss. This switching circuit will also demonstrate high isolation between the common port and the three open ports, as well as high isolation between each of the selectable ports.

While the design depicted by Figure 1 is believed to be novel, it has several flaws. Ideally, all four MEMS devices 10-1 through 10-4 should be clustered as close as reasonably possible around a single point 6. In Figure 1, note that switches 10 have different spacings from end point 6. When the switches 10 are separated by a length of transmission line, as is the case in Figure 1, that length of transmission line will then serve as a parasitic reactance to some of the ports. For example, in Figure 1, the length or portion of transmission line designated by the letter "L" appears as an open microstrip stub to ports 1 and 2. This length L of microstrip 6 is referred to as a "stub" in the antenna art and it affects the impedance of the circuit in which it appears. The effect, in this embodiment, is likely to be undesirable. Unfortunately, the second pair of ports 3, 4 likely may not be brought any closer to the first pair 1, 2, because this would cause unwanted coupling between the closely spaced sections of microstrip line that would result. Furthermore, if one wanted to compensate for the parasitic reactance caused by the microstrip stub, one would need to separately tune each of the lines because they do not all see the same reactance. There may not be space on the top side of the circuit to allow a separate tuning element for each of the selectable ports, and still allow room for the DC bias lines and the RF signal lines.

25

**Brief Description**

Figure 1 depicts a rather straightforward way of combining single-pole, single-throw RF MEMS switches into a single-pole, multi-throw hybrid design; however, the preferred designs  
5 are described with reference to the remaining figures.

In one aspect, the invention provides a switch arrangement comprising a plurality of MEMS switches arranged on a substrate about a central point, each MEMS switch being disposed on a common imaginary circle centered on said central point, and each MEMS switch being spaced  
10 equidistantly along the circumference of said imaginary circle; and connections for connecting a RF port of each one of said MEMS switches with said central point.

In another aspect, the invention provides a method of making a switch arrangement comprising: disposing a plurality of MEMS switches on a substrate in a circular pattern about a point;  
15 disposing a plurality of RF lines disposed in a radial pattern relative to said point on said substrate; and connecting said plurality of RF strip lines to a common junction point at said point on said substrate via said plurality of MEMS switches whereby operation of a one of said plurality of MEMS switches couples a one of said plurality of RF strip lines to said common  
junction.

20

**Brief Description of the Drawings**

Figure 1 depicts one technique for combining single-pole, single-throw RF MEMS switches into a single-pole, multi-throw hybrid design;  
25

Figures 2a and 2b are top and side elevation views of one embodiment of the present invention;

Figures 3a and 3b are top and side elevation views of another embodiment of the present

invention;

Figure 4 shows a modification to the embodiment of Figures 3a and 3b;

- 5 Figures 5a and 5b are top and side elevation views of yet another embodiment of the present invention;

Figures 6a and 6b are top and side elevation views of still another embodiment of the present invention;

10

Figure 7 depicts a switching arrangement of Figures 5a and 5b used in combination with a flared notch antenna;

- Figure 8 depicts a switching arrangement of Figures 5a and 5b used in combination with a  
15 flared notch antenna having eight flared notch elements; and

Figure 9 depicts another improvement compared to the switch of Figure 1.

## 20 **Detailed Description**

Recall Figure 1 and the fact that this design poses a number of problems in terms of the impedances seen from the common port of the microstrip line 6 when the various ports 1 - 4 are switched on. One solution to this problem is shown in Figures 2a and 2b. The structure of  
25 Figures 2a and 2b preferably consists of a multi-layer printed circuit board 12, on which a common RF line 14 is formed on the bottom side 13 of the board 12, and is fed through a ground plane 18 by a metal plated via 20 to a central point 7 in the center of a 1x4 switch matrix of switches 10-1 through 10-4, which switches may be made as a hybrid on a common



substrate (not shown) or which may be individually attached to surface 9. Switches 10-1 through 10-4 comprise a set of RF MEMS switches 10 (the numeral 10 when used without a dash and another numeral is used herein to refer to these RF MEMS switches in general as opposed to a particular switch). As will be seen, the number of switches 10 in the set can be  
5 greater than four, if desired.

RF MEMS switches 10 are positioned around common point 7, preferably in a radial geometry as shown. The benefit of this geometry is that each of the selectable ports 1 - 4 sees the same RF environment (including the same impedance) by utilizing the same local geometry which is  
10 preferably only varied by rotation about an axis "A" defined through common point 7.

Therefore, each of the ports 1-4 should have the same RF performance (or, at least, nearly identical RF performances to each other). Furthermore, since this geometry permits the MEMS devices 10 to be clustered as closely as possible around common point 7, parasitic reactance should be minimized. Moreover, for the case of a 1x4 switch matrix, control line pairs 11 can  
15 be arranged at right angles to each other, resulting in very low coupling between them. This embodiment has four ports, but, as will be seen, this basic design can be modified to provide a greater (or lesser) number of ports.

The MEMS switches 10 are preferably disposed in a circular arrangement around central point  
20 7 on substrate 12. Note that the switches 10 lie on a circular arrangement as indicated by the circular line identified by the letter B. Note also that the switches are preferably arranged equidistantly along the circumference of the circular line identified by the letter B. The MEMS switches 10 can be placed individually directly on surface 9 of the circuit board 12 or they may be formed on a small substrate (not shown) as a switch hybrid, which is in turn mounted on  
25 surface 9.

Via 20 preferably has a pad 8 on the top surface of the printed circuit board 12 to which the MEMS switches 10 can be wired, for example, using ball bonding techniques. The switches 10

are also wired to the control lines pairs 11 and to the ports 1 - 4.

In Figure 2a common port 7 is fed from the underside of the ground plane through a vertical metal plated via 20 to the top side of the board 12 where it terminates at central point 7. MEMS switches 10 are radially clustered around this central point. The centers of the MEMS switches 10 are preferably spaced a common distance (a common radius) away from an axis A of the via 20. This allows a large number of switches 10 to be fit into a small area, yet allows the coupling between the ports to be minimized. In the particular case of the 1x4 switch, with MEMS switches 10-1 - 10-4, the coupling is further minimized by the fact that the RF microstrip lines directed to ports 1 - 4 are disposed at right angles to each other. The substrate 12 of this structure preferably is a multi-layer microwave substrate with a buried ground plane 18.

The RF microstrip lines coupling to ports 1 - 4 may form the driven elements of an antenna structure, for example, or may be coupled to antenna elements. Such elements may be used for sending and/or receiving RF signals.

Figures 3a and 3b show another embodiment of the present invention, in which some of the DC bias lines are implemented as vias 21 which connect with the buried ground plane 18 in substrate 12. The vias 21 may have pads 8 formed on their top surfaces in order to facilitate connecting the ground connections on the MEMS switches 10 thereto. Since each bias line pair 11 consists of a ground line 24 and a signal or control line 23, each of the ground lines 24-1 - 24-4, may be tied to the RF ground plane 18, with no loss of performance, by means of vias 21. This results in fewer external connections to the circuit because only one DC control connection 23-1 - 23-4 is needed for each switch 10-1 - 10-4, which is half as many total connections compared with the embodiment of Figures 2a and 2b.

An additional possible advantage of the geometry of Figures 3a and 3c is shown in Figure 4. A feed-through via 20 such as that used for the common port 7 can sometimes have its own

parasitic reactance. By providing a complementary reactance  $Z$  as an external lumped element 25, one may optimize the RF match of the circuit. In Figure 4 the reactance  $Z$  couples via 20 to ground using one of the vias 21 coupled to ground plane 18. Since the impedance match is done on the central port 7, and all other ports are symmetrical, the same matching structure  $Z$  will  
5 work for all of the ports. This lumped element solution is one example of a matching structure, and others will be apparent to those skilled in the art of RF design. The ground connections of the MEMS switches 10 are wired to metal plated vias 21 directly or to their associated pads 8, either of which is in electrical communication with the buried ground plane 18. Note that the via 20 that provides the central RF port passes through a hole or opening 19 in the ground plane  
10 18, while the vias 21 contact the ground plane 18.

As in the case of Figures 2a and 2b, the plurality of MEMS switch devices 10-1 10-4 of Figures 3a, 3b and 4 are arranged on substrate 12 about a vertical axis A through the substrate, each switch 10 being disposed in a circular arrangement centered on axis A (central point 7)  
15 with each switch 10 being preferably spaced equidistantly along the circumference of the imaginary circle B defining the circular arrangement. Thus, the MEMS switches 10 are preferably disposed in a circular arrangement around central point 7 on substrate 12. Note that the switches 10 lie on indicated by the circular line identified by the letter B. Note also that the switches are preferably arranged equidistantly along the circumference of the circular line  
20 identified by the letter B.

In Figures 2a and 3a the DC control lines 11 and 22 are depicted as being thinner than are the RF lines 1 - 4. If the DC lines are much thinner than the RF lines, they will have a higher impedance and coupling with the RF lines will be thereby reduced. While the percentage by  
25 which the DC are made thinner than the RF lines is somewhat a matter of tradeoffs, it is believed their width should preferably be about 25% of the width of the RF lines or less. The DC lines should be separated by at least one RF line width from the RF lines to reduce unwanted coupling. The MEMS switches may be wired to their RF lines, DC control lines,

ground pads or lines by means of wires 13 bonded to the respective switches 10 and their various lines and/or pads.

Yet another embodiment of this structure is shown in Figures 5a and 5b. In this embodiment, both the DC bias switch control lines 23, 24 associated with each switch 10 are fed through vertical metal plated vias 21, 26. For each switch 10, one of the lines (line 24) is grounded by means of via 21 contacting ground plane 18 and the other line (line 23) is connected, by means of a via 26 through a hole in the ground plane 18, to a trace 27 on the back side of the board 12 which functions as a MEMS switch 10 control line. This reduces clutter (lines which do not directly assist the RF capabilities of the switch arrangement) on the front of the board, and can allow for more complex switching circuits and for reduced coupling between the RF lines and the DC bias lines 11.

In the embodiment of Figures 5a and 5b, all of the DC bias lines 11 pass through metal plated vias 21, 26. Half of them contact the ground plane 18 and the other half pass through the ground plane to contact traces 27 on the back side 13 of the board 12.

Several geometries have been described which are based on a common theme of a radial switching structure, with discrete RF MEMS devices 10 assembled around a common input port 7 of microstrip line 14, and routing RF energy to one of several output ports (for example, ports 1 - 4 in a four port embodiment).

It should be understood that the operation of the disclosed device is reciprocal, in that the various ports described as the output ports could also serve as a plurality of alternate input ports which are fed to a common output port which is the central point 7. Furthermore, it should be understood that although 1x4 switching circuits have been shown, other numbers of switches in the switching circuits are possible such as 1x6 and 1x8 and possibly even higher numbers, and that these designs will be apparent to one skilled in the art of RF design after fully

understanding the disclosure of this patent document. However, a large number of ports may be difficult to realize due to crowding of the RF lines and the DC bias lines. This issue can be addressed by using the modification shown in Figures 6a and 6b. In this embodiment, the RF and DC signals share lines 1, 2, 3, 4. Both the RF and the DC ports of the MEMS switches 10-1 ... 10-4 are connected together, as shown in Figure 6a. The DC portion of the signal may be separated from the RF portion by using an inductor 32-1 ... 32-4 in each of the switches' DC circuit. This may be either a lumped element, a printed inductor, or an inductive structure such as a very high-impedance RF line. Another inductor 34 may be needed to separate the RF signal from the DC ground as shown in Figure 6b. In that case, the end of inductor 34 remote from the connection to via 20 is coupled to a line 15 at ground potential. If it is necessary to prevent the DC signal from reaching other RF components, then an external DC blocking capacitor may be used on each of the RF lines. These capacitors are not shown in the figures. Figures 6a and 6b show a four port arrangement, but it is to be understood that this modification would be more apt to be used where space constraints do not allow the other embodiments to be easily utilized.

In another aspect of this invention, the radial switching structure described above is combined with a printed antenna structure which may or may not share the same substrate 12. In the embodiment of Figure 7, the printed antenna structure 40 preferably includes four conductive cloverleaf elements 36 which define flared notch antennas 37 therebetween. The DC bias lines 11a disposed on the back side of the board, as well as the common RF line 14, also on the backside of the board, are shown in dashed lines. The selectable RF lines on the front side of the board are shown in solid lines. The conductive cloverleaf elements are preferably formed on one surface of board 12 using conventional printed circuit board fabrication techniques. Thus, the cloverleaf elements 36 may be made by appropriately etching a copper-clad printed circuit board, for example. The lines on the bottom side (shown dashed) can be similarly made by appropriately etching a copper-clad printed circuit board.

Each flared notch 37 is fed by a separate microstrip line 1- 4, each of which crosses over the notch of an antenna and is shorted to the ground plane 18 (see, e.g., Figure 5b) on the opposite side of board 12 at vias 39. These microstrip lines correspond to the similarly numbered ports 1-4 discussed with respect to the switch arrangements of the earlier mentioned figures. RF energy passing down these microstrip lines is radiated from the associated antenna structure in a direction that antenna is pointing (i.e. along the mid-points of the notch of the notch antenna which is excited). The DC bias lines 11 and 11a are preferably routed to a common connector 41 on the bottom side of the board 12 and the RF input preferably comprises a single feed point 42 which is routed to one of the four antenna structures (by means of one of the microstrips 1 - 4) as determined by which MEMS switch 10 (see Figure 5a - the switches 10 are too small to be shown clearly on Figure 7, but they are clustered around point 7) is closed. Bias lines 11 are disposed on the top side of board 12 while bias lines 11a are disposed on the bottom side thereof. They are coupled together through the board 12 by means of vias. A pad 8 of one via is numbered in Figure 7 (the other vias are unnumbered due to the limited space available around them for reference numerals, but the vias can, nevertheless, be easily seen). The vias in Figure 7 are shown spaced further from the center point 7 than they would be in an actual embodiment, merely for ease of illustration.

An embodiment more complicated than that of Figure 7 is shown in Figure 8. This embodiment has eight flared notches 37 defined by cloverleaf elements 36 and a single 1x8 array of RF MEMS switches 10 at the central point 7 (see Figure 5a - the switches 10 are again too small to be shown easily on Figure 8, but they are nevertheless clustered around central point 7). This antenna uses the 1x8 MEMS switch to route the common input port to one of eight flared notch antennas 37. This drawing only shows the general concept of the structure and does not show the required DC bias lines or inductors. But those bias lines would be similar to those shown in Figure 7, but more numerous given the fact that this embodiment has eight notches 37 rather than four notches 37.

Figures 7 and 8 demonstrate that the matrix of single-pole, multi-throw MEMS switches can be combined with an antenna structure 40 to create a switched beam diversity antenna of rather inexpensive components. The structure shown by Figure 7 uses four flared notches 37, which are addressed by a 1x4 MEMS switch matrix preferably arranged in the radial configuration  
5 described above.

The preferred embodiment of the hybrid single-pole, multi-throw switch has been described with reference to Figures 3a and 3b. It is felt that this embodiment can be rather easily manufactured. The antenna cloverleaf design of Figure 8 is preferred since eight slots provide  
10 good diversity control. However, there may be other embodiments, and other ways of solving the problems associated with the candidate structure described with reference to Figure 1. One such solution is shown in Figure 9.

The embodiment of Figure 9 is not a presently preferred embodiment of this invention, but it is  
15 an embodiment that may have sufficient advantages in certain applications, such as when metal plated vias cannot be used, that some practicing the present invention may choose to utilize it. This may be the case when a monolithic approach is taken, when vias and internal ground layers may not be feasible or may not be simple to realize. This embodiment builds on the concept that the individual MEMS devices 10 are preferably clustered as closely as possible  
20 around a central point 7 to avoid parasitic reactance. This embodiment also recognizes that this may not be possible for a design to have a large number of ports, because when the microstrip transmission lines are brought too close to each other, unwanted coupling occurs. To address both of these problems, a 1x3 switching unit SU is used as a building block for a 1xN switch of any desired size. Each SU has a pair of MEMS switches 10 for coupling the transmission lines  
25 to a central point 7 of the SU. Each transmission line port 1,2 of a first unit is accessed through a MEMS device 10, while subsequent transmission line ports (for example, ports 3,4 of a second SU) are accessed through one or more third MEMS device(s) 45 which route the RF signals along sections of central transmission line 46 (which may now be of any length required

to minimize coupling between ports) to a next 1x3 switching unit SU. Each switching unit SU comprises two (or possibly more) MEMS switches 10 clustered around its own central point 7 for coupling the transmission lines thereto and another MEMS switch 45 for passing the incoming signal to yet another switching unit SU. In this and in each subsequent block SU, two additional (or more) transmission lines may be addressed each through their own individual MEMS device 10, or the signals may be sent to the next SU through the third MEMS device 45. Since unused sections of transmission line are switched off when they are not used, they do not present unwanted parasitic reactance. Of course, all of the DC bias methods described in previous embodiments may be applied to this structure as well. Furthermore, other structures that use the 1x3 building block in this way, to allow necessary but unwanted sections of transmission lines to be turned off when not in use, will be apparent after this invention is understood. One example of another design would be a corporate switching structure, as opposed to the linear one presented here. In a corporate structure one input feeds two outputs, each of which in turn feed two more outputs, and those outputs each in turn feed two more outputs, until you have  $2^n$  outputs at the end. When it is drawn, it looks like a corporate organization chart with many layers of middle management (hence the name).

Figure 9 thus depicts an alternate design that may be used if a central metal-plated via 20 feature of the earlier embodiments is not feasible. The design of Figure 9 uses a 1x3 switch SU as a building block for a 1xN switch of any size. It benefits from the knowledge that dangling sections of RF line will cause parasitic reactance when they are not used. In each 1x3 unit SU, the third switch 45 is opened if one of the ports on that unit is selected by means of closing its associated MEMS switch 10. If neither switch 10 is selected, the third switch 45 is closed, and the signal is routed to the next SU. By using this geometry, the sections of RF line between units can be as long as is needed to minimize coupling between the selectable ports, because those sections of RF line are switched off when not in use. Of course, this building-block approach can be used to make any geometry of 1xN switch.



The MEMS switches 10 are preferably disposed in a circular arrangement around central point 7. Note that in this embodiment the switches 10, 45 also preferably lie on an imaginary circle, here again identified by the letter B. Note also that the switches 10, 45 and segment 46 are preferably arranged equidistantly along the circumference identified by the letter B.

In the numbering of the elements in this description and in the drawings, numbers such as 10-2 appear. The first portion (the 10 in this case) refers to the element type (a MEMS switch in this case) and the second portion (the 2 in this case) refer to a particular one of those elements (a second MEMS switch 10 in this case). This numbering scheme is likely self-explanatory, but it is nevertheless here explained for the reader who might not have previously encountered it.

The MEM switches 10-1 ... 10-4 and 45 may be provided with integral impedance matching elements, such as capacitors, in order to increase the return loss to more than 20 dB. For that reason, the MEM switches disclosed by US Provisional Patent Application Serial Number \_\_\_\_\_ filed \_\_\_\_\_ and entitled "RF MEMS Switch with Integrated Impedance Matching Structure" (attorney docket 620650-7) are believed to be the preferred MEM switches for use in connection with this invention.

One embodiment according to the present invention is

a switch arrangement comprising plurality of MEMS switches arranged on a substrate about a central point, each MEMS switch being disposed on a common imaginary circle centered on the central point. Additionally, each MEMS switch is preferably spaced equidistantly along the circumference of the imaginary circle. Connections are provided for connecting a RF port of each one of the MEMS switches with the central point.

Having described the invention in connection with certain embodiments thereof, modification will now certainly suggest itself to those skilled in the art. As such, the invention is not to be limited to the disclosed embodiments except as required by the appended claims.

What is claimed is:

1. A switch arrangement comprising:
  - (a) a plurality of MEMS switches arranged on a substrate about an axis through said substrate, each MEMS switch being disposed on a common imaginary circle centered on said axis, and each MEMS switch being spaced equidistantly along the circumference of said imaginary circle;
  - (b) a conductive via in said substrate arranged parallel to and on said axis; and
  - (c) connections for connecting a RF port of each one of said plurality of MEMS switches with said conductive via.
  
2. A switch arrangement comprising a plurality of switch units, each switch unit having at least two MEMS switches coupled to a central point, the at least two MEMS switches of the switch unit being arranged to couple selectively at least two transmission line ports to said central point, and at least a third MEMS switch coupled to said central point and adapted to be connected to a central point associated with an adjacent one of said plurality of switch units.
  
3. A switch arrangement comprising:
  - (a) a plurality of MEMS switches arranged on a substrate about a central point, each MEMS switch being disposed on a common imaginary circle centered on said central point, and each MEMS switch being spaced equidistantly along the circumference of said imaginary circle; and
  - (b) connections for connecting a RF port of each one of said MEMS switches with said central point.
  
4. A method of making a switch arrangement comprising:
  - (a) disposing a plurality of MEMS switches on a substrate in a circular pattern about a point;
  - (b) disposing a plurality of RF lines disposed in a radial pattern relative to said point on said substrate; and

(c) connecting said plurality of RF lines to a common junction point at said point on said substrate via said plurality of MEMS switches whereby operation of a one of said plurality of MEMS switches couples a one of said plurality of RF strip lines to said common junction.

5. The switch arrangement of claim 1 wherein the substrate has a ground plane therein, said conductive via passing through said ground plane without contacting said ground plane.

6. The switch arrangement of claim 5 further including a plurality of strip lines, each one of said plurality of strip lines being coupled to a RF contact of one of said plurality of MEMS switches.

7. The switch arrangement of claim 6 wherein said plurality of strip lines are radially arranged relative to said axis.

8. The switch arrangement of claim 3 wherein at least two of the MEMS switches are arranged to couple selectively at least two transmission lines to said central point and wherein a pair of the at least two transmission lines are disposed co-linearly of each other.

9. The switch arrangement of claim 8 wherein at least one of the MEMS switches is arranged to couple selectively the central point of the switch arrangement to a central point associated with another switch arrangement via a transmission line segment.

10. The switch arrangement of claim 8 wherein the substrate has a ground plane therein and the switch arrangement further includes a conductive via in said substrate arranged parallel to and on a vertical axis which is normal to a major surface of substrate and which passes through said central point, the conductive via passing through said ground plane without contacting same.

11. The switch arrangement of claim 10 further including a plurality of strip lines, each one of said plurality of strip lines being coupled to a RF contact of one of said plurality of MEMS switches.
12. The switch arrangement of claim 11 wherein said plurality of strip lines are radially arranged relative to said central point.
13. The switch arrangement of claim 7 or claim 12 wherein said plurality of strip lines and said plurality of MEMS switches are disposed on a first major surface of said substrate.
14. The switch arrangement of claim 13 further including a plurality of control lines disposed on said first major surface of said substrate, each control line being coupled to an associated one of said plurality of MEMS switches and being disposed between two adjacent strip lines of said plurality of strip lines.
15. The switch arrangement of claim 14 further including a plurality of conductive vias in said substrate arranged parallel to said axis and contacting said ground plane, each of said plurality of MEMS switches having a DC ground contact which is wired to a one of a plurality of conductive vias contacting said ground plane.
16. The switch arrangement of claim 15 further including an impedance device coupling a conductive via on the central point to one of the plurality of conductive vias, the impedance device being disposed adjacent a second major surface of said substrate.
17. The switch arrangement of claim 13 further including a plurality of control lines arranged in pairs and disposed on said first major surface of said substrate, each control line pair being coupled to an associated one of said plurality of MEMS switches and being disposed between two adjacent strip lines of said plurality of strip lines.
18. The switch arrangement of claim 14 or claim 17 wherein each of the plurality of control lines has a first width and wherein each of the plurality of strip lines has a second

width, the second width being at least three times greater than the first width.

19. The switch arrangement of claim 2 wherein each switch unit has a centrally disposed transmission line, the centrally disposed transmission line connecting the switch unit to the at least a third MEMS switch associated with an adjacent one of said plurality of switch units.

20. The switch arrangement of claim 19 wherein the centrally disposed transmission line is linearly arranged from the central point of each switch unit towards the at least a third MEMS switch associated with an adjacent one of said plurality of switch units.

21. An antenna comprising a plurality of end fire Vivaldi antennas arranged in a cloverleaf configuration in combination with the switch arrangement of claim 3 for controlling which one or ones of said plurality of end fire Vivaldi antennas is or are active.

22. An antenna comprising a plurality of end fire Vivaldi antennas arranged in a cloverleaf configuration in combination with the switch arrangement of claim 3 for controlling which one of said plurality of end fire Vivaldi antennas is active.

23. The method of claim 4 wherein at least two of the MEMS switches of said plurality of MEMS switches are arranged to couple selectively at least two RF lines to said point and wherein a pair of the at least two RF lines are disposed co-linearly of each other.

24. The method of claim 23 wherein at least one of the MEMS switches of said plurality of MEMS switches is arranged to couple selectively the common junction point to another common junction point associated with another switch arrangement made according to the method of claim 4 via a transmission line segment disposed on said substrate.

25. The method of claim 24 further including providing a ground plane in the substrate and providing a conductive via in said substrate arranged parallel to and on an axis through

said point and normal to a major surface of said substrate, the conductive via passing through said ground plane without contacting same.

26. The method of claim 25 further including disposing a plurality of strip lines on said surface and coupling each one of said plurality of strip lines to a RF contact of one of said plurality of MEMS switches.

27. The method of claim 26 wherein said plurality of strip line and said plurality of MEMS switches are disposed on the first major surface of said substrate.

28. The method of claim 27 further including disposing a plurality of control lines on the first major surface of said substrate, each control line being coupled to an associated one of said plurality of MEMS switches and being disposed between two adjacent strip lines.

29. The method of claim 28 further including providing a plurality of conductive vias in said substrate arranged parallel to said axis and contacting said ground plane, each of said plurality of MEMS switches having a DC ground contact which is wired to a one of the plurality of conductive vias contacting said ground plane.

30. The method of claim 29 further including coupling an impedance device between (i) the conductive via connected to the common junction point and (ii) at least one of the plurality of conductive vias, the impedance device being disposed adjacent a second major surface of said substrate.

31. The method of claim 26 further including disposing a plurality of control lines arranged in pairs on the first major surface of said substrate, each control line pair being coupled to an associated one of said plurality of MEMS switches and being disposed between two adjacent strip lines.

32. A switch arrangement comprising:  
(a) a plurality of MEMS switches arranged on a substrate about a common RF port,

the RF port having a centerline and each MEMS switch being disposed spaced equidistantly from the centerline of said RF port; and

(b) connections for connecting a RF contact of each one of said MEMS switches with said common RF port.

33. The switch arrangement of claim 32 wherein the centerline of the RF port is disposed perpendicular to a major surface of said substrate.

34. The switch arrangement of claim 33 wherein the centerline of the RF port is disposed parallel to a major surface of said substrate.

35. A switch arrangement comprising:  
a plurality of MEMS switches arranged on a substrate;  
a conductive via in said substrate; and  
a connection for connecting a RF port of at least one MEMS switch with said conductive via.

36. A switch arrangement comprising:  
a plurality of MEMS switches arranged on a substrate about a central point; and  
connectors for connecting a RF port of at least one MEMS switch with said central point.

37. A method of making a switch arrangement comprising:  
disposing a plurality of MEMS switches on a substrate about a point;  
disposing a plurality of RF lines on said substrate; and  
connecting said plurality of RF lines to a common junction point at said point on said substrate via said plurality of MEMS switches.

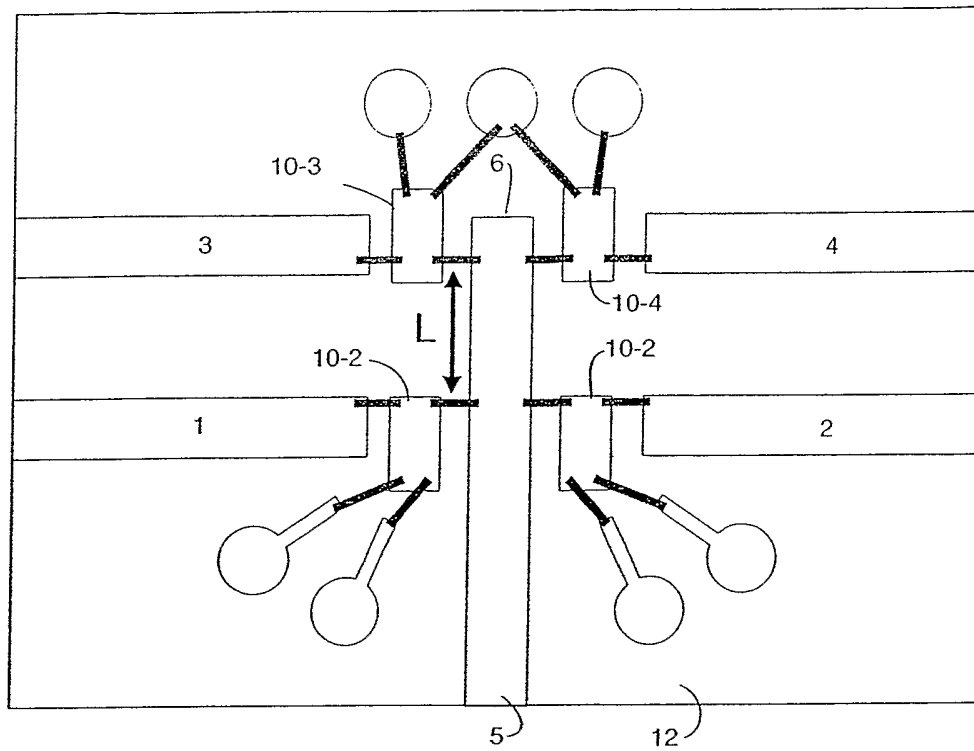

Figure 1





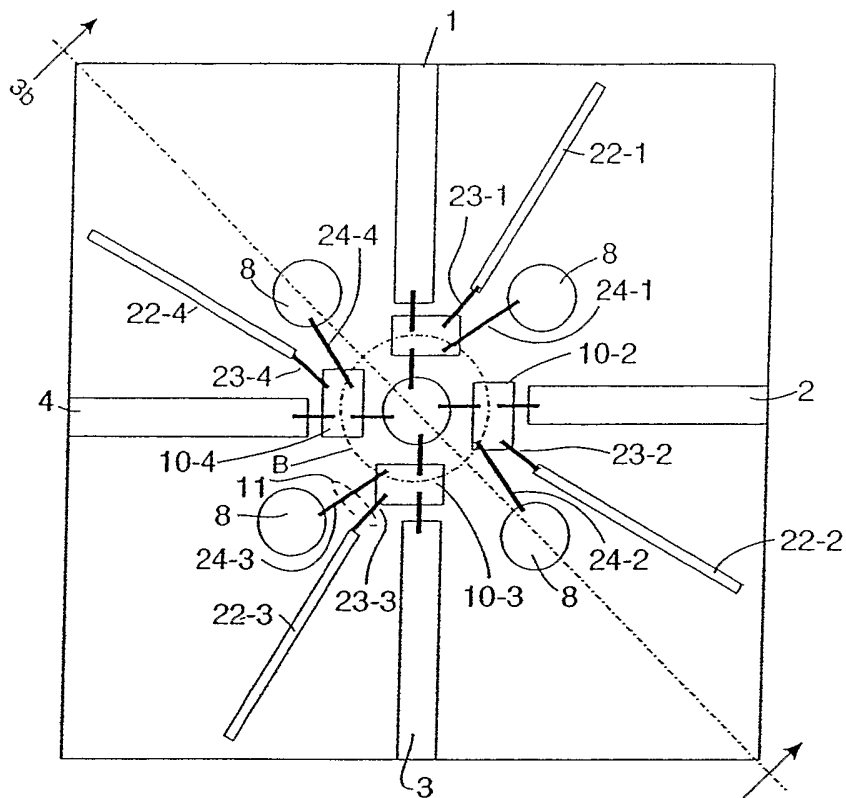

Figure 3a

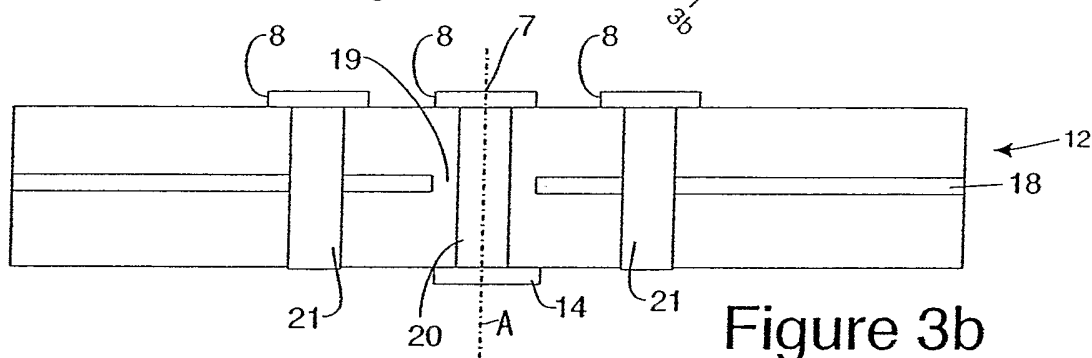

Figure 3b

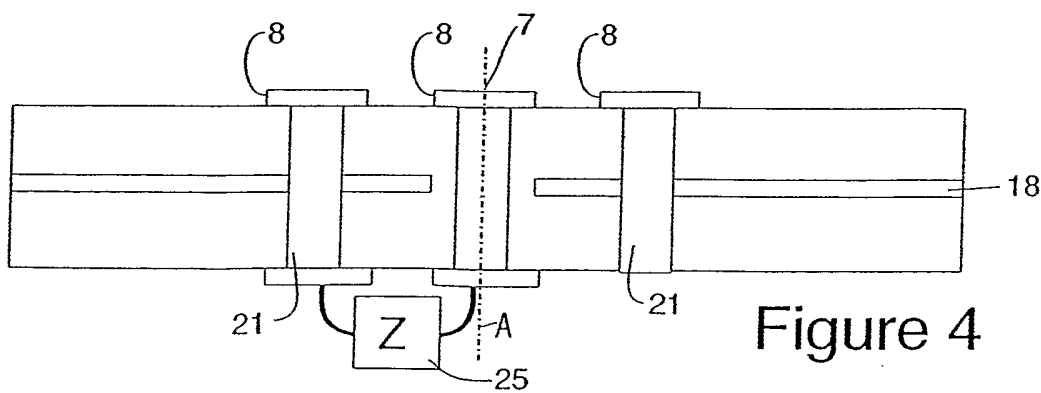

Figure 4

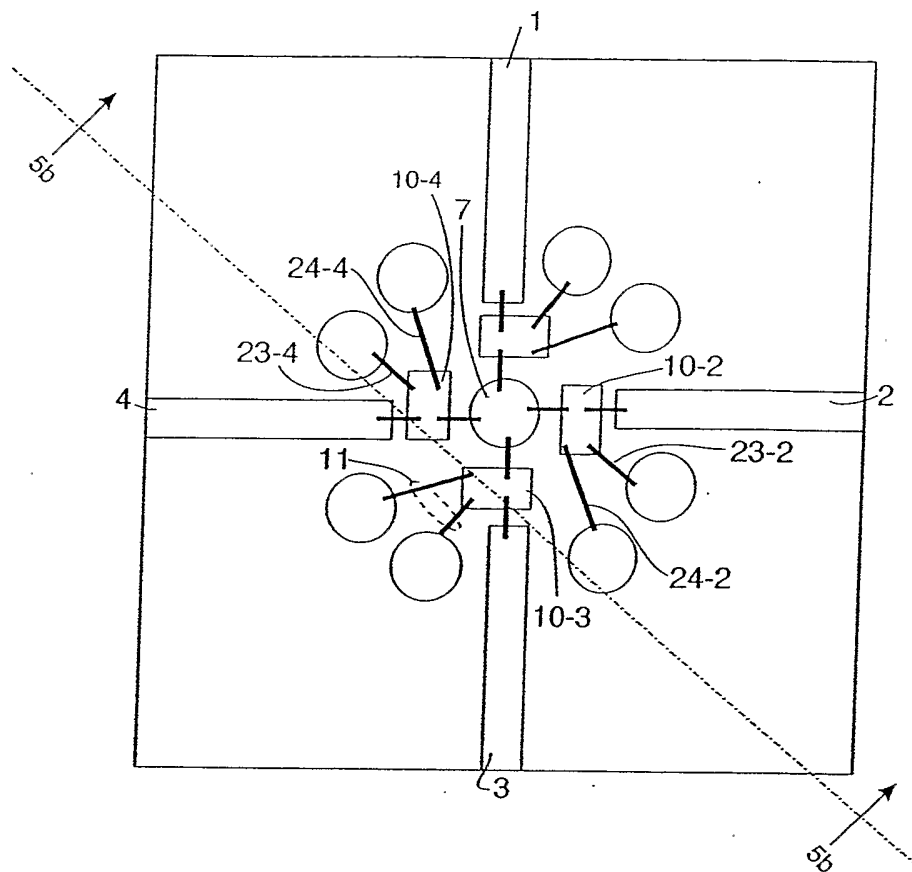

Figure 5a

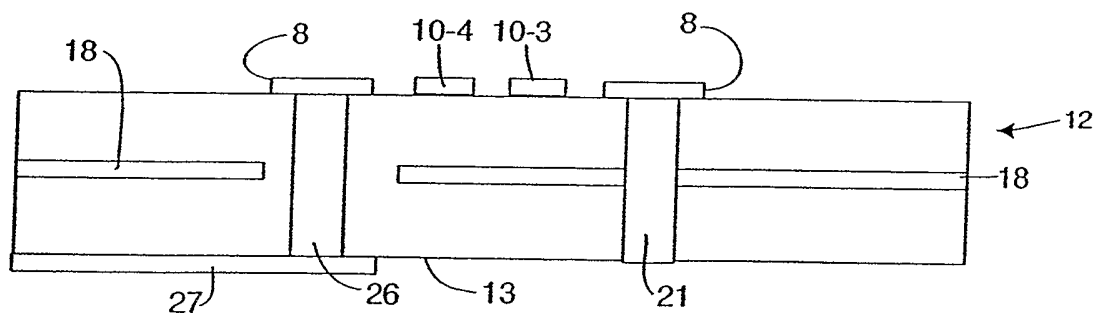

Figure 5b

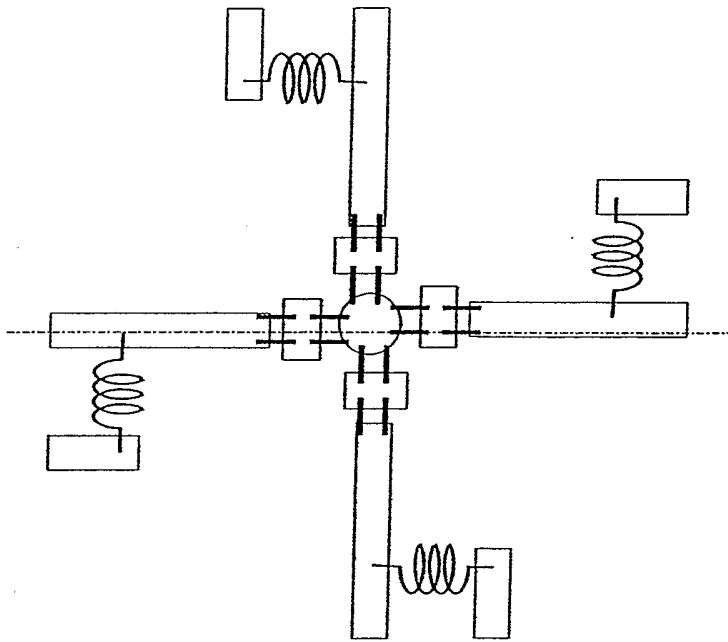

Figure 6a

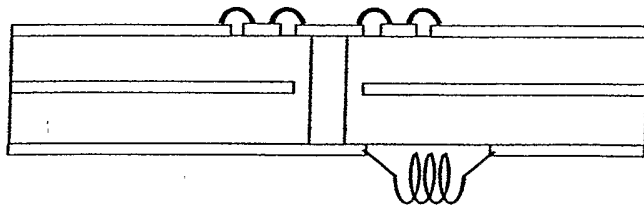

Figure 6b

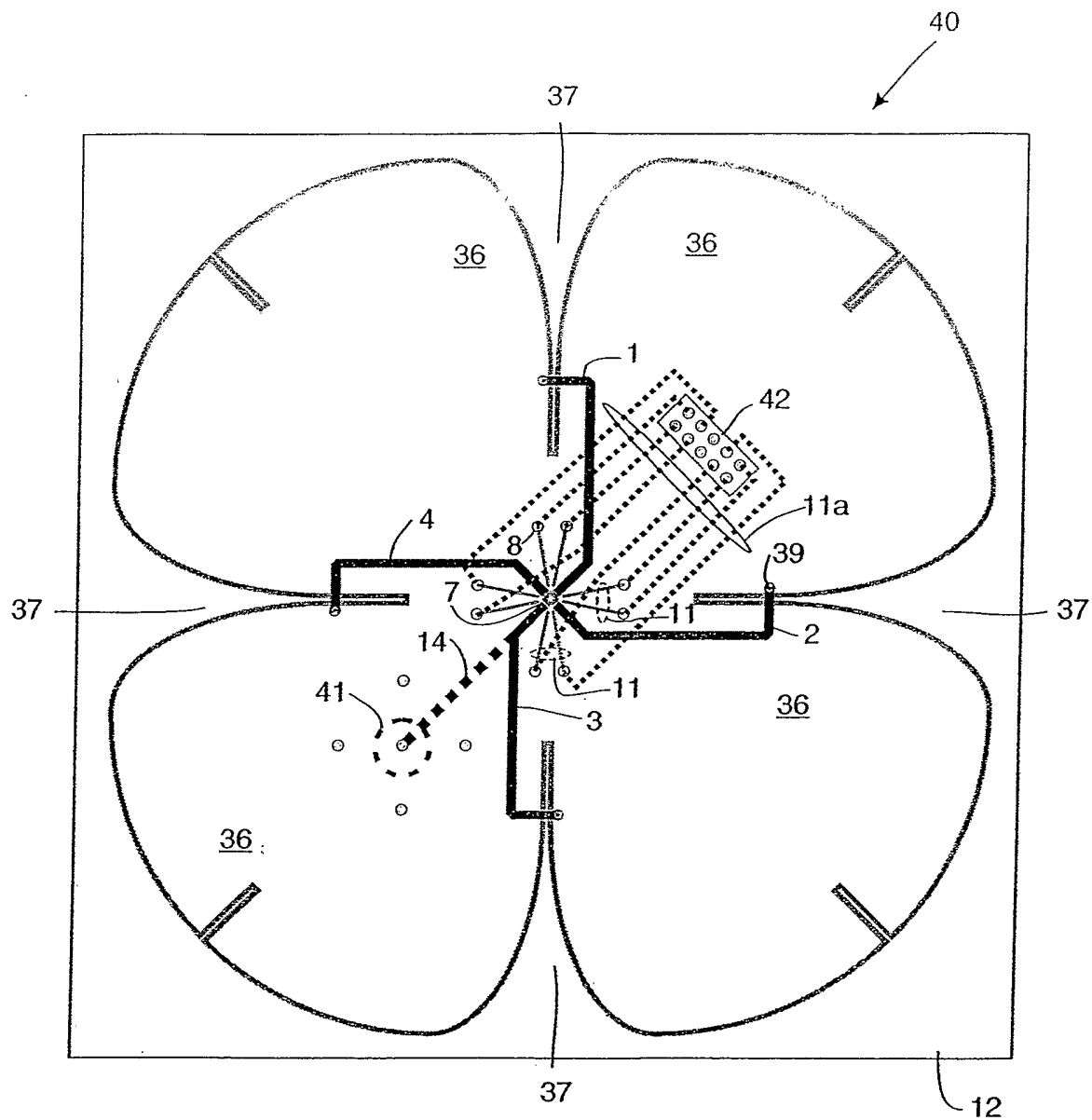

Figure 7

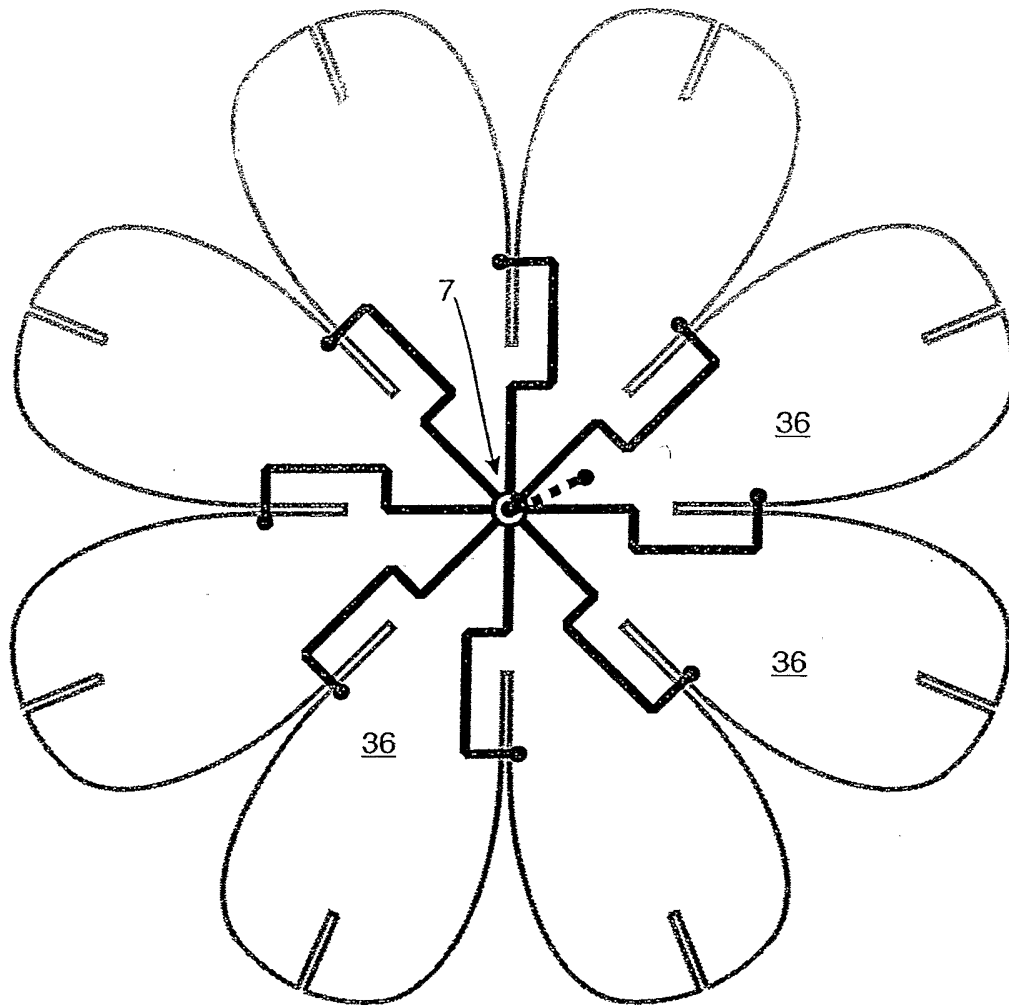

Figure 8

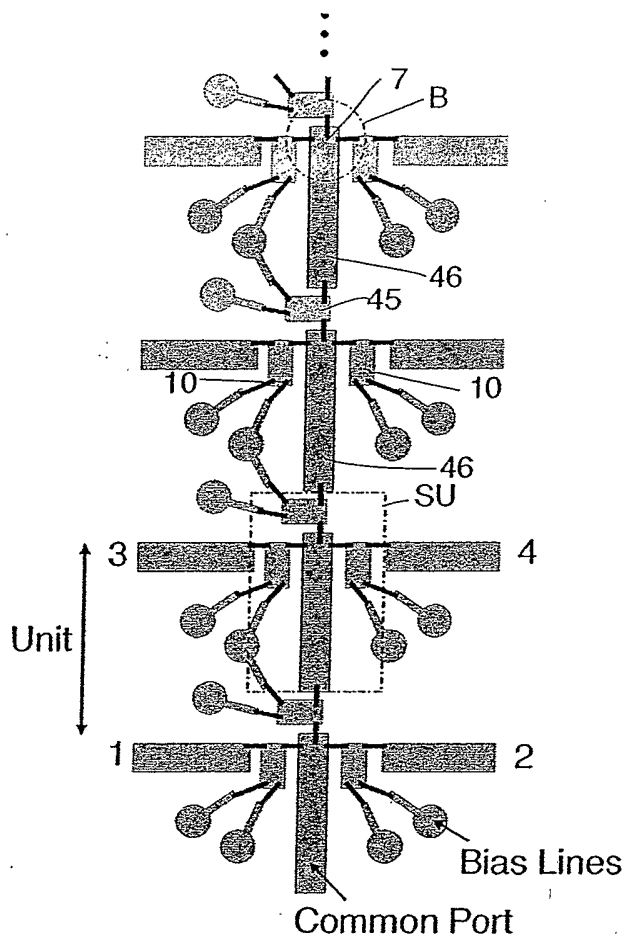

Figure 9

INTERNATIONAL SEARCH REPORT

International Application No  
PCT/US 03/15479

<p><b>A. CLASSIFICATION OF SUBJECT MATTER</b> IPC 7 H01P1/12</p>		
<p>According to International Patent Classification (IPC) or to both national classification and IPC</p>		
<p><b>B. FIELDS SEARCHED</b></p>		
<p>Minimum documentation searched (classification system followed by classification symbols) IPC 7 H01P H01H H01Q</p>		
<p>Documentation searched other than minimum documentation to the extent that such documents are included in the fields searched</p>		
<p>Electronic data base consulted during the international search (name of data base and, where practical, search terms used) EPO-Internal, PAJ</p>		
<p><b>C. DOCUMENTS CONSIDERED TO BE RELEVANT</b></p>		
Category <sup>o</sup>	Citation of document, with indication, where appropriate, of the relevant passages	Relevant to claim No.
X	US 2002/036586 A1 (GOTHARD ET AL.) 28 March 2002 (2002-03-28) paragraphs '0032!', '0033!', '0039!'-'0041!', '0052!'-'0056!; figures 3,4,9	1-4, 32, 33, 35-37
A	GB 1 145 208 A (MARCONI INSTRUMENTS LTD) 12 March 1969 (1969-03-12) page 2, line 101 -page 3, line 6; figure 4 -/--	1-4, 32, 35-37
<p><input checked="" type="checkbox"/> Further documents are listed in the continuation of box C.      <input checked="" type="checkbox"/> Patent family members are listed in annex.</p>		
<p><sup>o</sup> Special categories of cited documents :</p>		
<p>*A* document defining the general state of the art which is not considered to be of particular relevance</p>		
<p>*E* earlier document but published on or after the International filing date</p>		
<p>*L* document which may throw doubts on priority claim(s) or which is cited to establish the publication date of another citation or other special reason (as specified)</p>		
<p>*O* document referring to an oral disclosure, use, exhibition or other means</p>		
<p>*P* document published prior to the international filing date but later than the priority date claimed</p>		
<p>*T* later document published after the international filing date or priority date and not in conflict with the application but cited to understand the principle or theory underlying the invention</p>		
<p>*X* document of particular relevance; the claimed invention cannot be considered novel or cannot be considered to involve an inventive step when the document is taken alone</p>		
<p>*Y* document of particular relevance; the claimed invention cannot be considered to involve an inventive step when the document is combined with one or more other such documents, such combination being obvious to a person skilled in the art.</p>		
<p>*Z* document member of the same patent family</p>		
<p>Date of the actual completion of the international search</p>		<p>Date of mailing of the international search report</p>
<p>1 August 2003</p>		<p>08/08/2003</p>
<p>Name and mailing address of the ISA European Patent Office, P.B. 5818 Patentlaan 2 NL - 2280 HV Rijswijk Tel. (+31-70) 340-2040, Tx. 31 651 epo nl, Fax: (+31-70) 340-3016</p>		<p>Authorized officer Den Otter, A</p>



## INTERNATIONAL SEARCH REPORT

International Application No

PCT/US 03/15479

C.(Continuation) DOCUMENTS CONSIDERED TO BE RELEVANT		
Category °	Citation of document, with indication, where appropriate, of the relevant passages	Relevant to claim No.
A	<p>BIALKOWSKI M E ET AL: "Electronically steered antenna system for the australian mobilesat"            IEE PROCEEDINGS: MICROWAVES, ANTENNAS AND PROPAGATION, IEE, STEVENAGE, HERTS, GB, vol. 143, no. 4,            13 August 1996 (1996-08-13), pages 347-352, XP006006573            ISSN: 1350-2417            page 349, left-hand column, line 13            -right-hand column, line 20; figure 6            ---</p>	1-4, 32, 35-37
A	<p>PATENT ABSTRACTS OF JAPAN            vol. 011, no. 113 (E-497),            9 April 1987 (1987-04-09)            -&amp; JP 61 260702 A (HITACHI LTD),            18 November 1986 (1986-11-18)            abstract; figures 1,2            ---</p>	1-4, 32, 35-37
A	<p>WO 01 31737 A (ALLGON AB ;DONGHUI LIU (SE); ERIKSSON LEIF (SE); BRAUN CHRISTIAN ()) 3 May 2001 (2001-05-03)            page 6, line 15 -page 8, line 11; figure 1            -----</p>	1-4, 32, 35-37

## INTERNATIONAL SEARCH REPORT

International Application No

PCT/US 03/15479

Patent document cited in search report		Publication date	Patent family member(s)	Publication date
US 2002036586	A1	28-03-2002	NONE	
GB 1145208	A	12-03-1969	FR 1540069 A SE 341946 B	20-09-1968 17-01-1972
JP 61260702	A	18-11-1986	NONE	
WO 0131737	A	03-05-2001	SE 515378 C2 AU 1185201 A CN 1387688 T EP 1234352 A1 WO 0131737 A1 SE 9903942 A US 6392610 B1	23-07-2001 08-05-2001 25-12-2002 28-08-2002 03-05-2001 30-04-2001 21-05-2002