

(19) World Intellectual Property
Organization
International Bureau



(43) International Publication Date
2 December 2004 (02.12.2004)

PCT

(10) International Publication Number
WO 2004/103156 A2

- (51) International Patent Classification⁷: **A61B**
- (21) International Application Number:
PCT/US2004/015311
- (22) International Filing Date: 14 May 2004 (14.05.2004)
- (25) Filing Language: English
- (26) Publication Language: English
- (30) Priority Data:
60/470,632 15 May 2003 (15.05.2003) US

(81) Designated States (unless otherwise indicated, for every kind of national protection available): AE, AG, AL, AM, AT, AU, AZ, BA, BB, BG, BR, BW, BY, BZ, CA, CH, CN, CO, CR, CU, CZ, DE, DK, DM, DZ, EC, EE, EG, ES, FI, GB, GD, GE, GH, GM, HR, HU, ID, IL, IN, IS, JP, KE, KG, KP, KR, KZ, LC, LK, LR, LS, LT, LU, LV, MA, MD, MG, MK, MN, MW, MX, MZ, NA, NI, NO, NZ, OM, PG, PH, PL, PT, RO, RU, SC, SD, SE, SG, SK, SL, SY, TJ, TM, TN, TR, TT, TZ, UA, UG, US, UZ, VC, VN, YU, ZA, ZM, ZW.

(71) Applicant (for all designated States except US): **SHERWOOD SERVICES AG** [CH/CH]; Bahnhofstrasse 29, CH-8200 Schaffhausen (CH).

(84) Designated States (unless otherwise indicated, for every kind of regional protection available): ARIPO (BW, GH, GM, KE, LS, MW, MZ, NA, SD, SL, SZ, TZ, UG, ZM, ZW), Eurasian (AM, AZ, BY, KG, KZ, MD, RU, TJ, TM), European (AT, BE, BG, CH, CY, CZ, DE, DK, EE, ES, FI, FR, GB, GR, HU, IE, IT, LU, MC, NL, PL, PT, RO, SE, SI, SK, TR), OAPI (BF, BJ, CF, CG, CI, CM, GA, GN, GQ, GW, ML, MR, NE, SN, TD, TG).

(72) Inventors; and
(75) Inventors/Applicants (for US only): **SHIELDS, Chelsea** [US/US]; 711B Alpine Avenue, Boulder, CO 80304 (US). **MEAGHER, Edward, C.** [US/US]; 12 Alvord Court, Greenlawn, NY 11740 (US).

Published:
— without international search report and to be republished upon receipt of that report

(74) Agents: **FARBER, Mark** et al.; US Surgical, A Division of Tyco Healthcare Group, LP, 150 Glover Avenue, Norwalk, CT 06856 (US).

For two-letter codes and other abbreviations, refer to the "Guidance Notes on Codes and Abbreviations" appearing at the beginning of each regular issue of the PCT Gazette.

(54) Title: TISSUE SEALER WITH NON-CONDUCTIVE VARIABLE STOP MEMBERS AND METHOD OF SEALING TISSUE

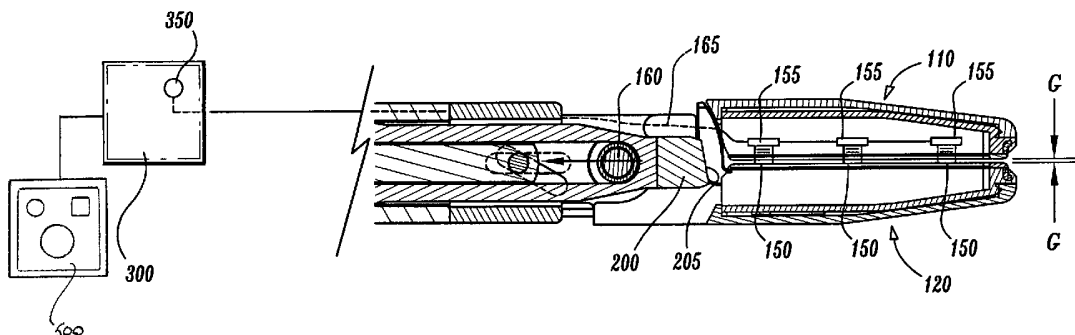

(57) Abstract: A bipolar forceps for sealing tissue includes an elongated shaft having opposing jaw members at a distal end thereof, each of the jaw members including an electrically conductive sealing surface. The jaw members are movable relative to one another from a first position wherein the jaw members are disposed in spaced relation relative to one another to a second position wherein the jaw members cooperate to grasp tissue therebetween. The bipolar forceps is connected to a source of electrical energy such that the jaw members are capable of conducting bipolar energy through tissue held therebetween to effect a seal. The forceps also includes a stop member assembly having at least one non-conductive stop member which is selectively extendible to regulate the distance between the jaw members when tissue is held therebetween.

WO 2004/103156 A2

**TISSUE SEALER WITH NON-CONDUCTIVE VARIABLE STOP MEMBERS
AND METHOD OF SEALING TISSUE**

CROSS REFERENCE TO RELATED APPLICATION

The present application claims the benefit of priority to U.S. Provisional Application Serial No. 60/470,632 filed on May 15, 2003 by Shields et al., the entire contents of which being incorporated by reference herein.

BACKGROUND

The present disclosure relates to an electrosurgical instrument and method for performing electrosurgical procedures. More particularly, the present disclosure relates to an open or endoscopic bipolar electrosurgical forceps and method of using same which includes a selectively-variable, non-conductive stop member associated with one or both of the opposing jaw members. The selectively-variable, non-conductive stop member is designed to control the gap distance between opposing jaw members and enhance the manipulation and gripping of tissue during the sealing process.

Technical Field

Forceps utilize mechanical action to constrict, grasp, dissect and/or clamp tissue. Electrosurgical forceps utilize both mechanical clamping action and electrical energy to effect hemostasis by heating the tissue and blood vessels. By controlling the intensity, frequency and duration of the electrosurgical energy applied

through the jaw members to the tissue, the surgeon can coagulate, cauterize and/or seal tissue.

In order to effect a proper seal with larger vessels or thick tissue, two predominant mechanical parameters must be accurately controlled: the pressure applied to the tissue; and the gap distance between the electrodes. As can be appreciated, both of these parameters are affected by the thickness of vessels or tissue. More particularly, accurate application of pressure is important for several reasons: to reduce the tissue impedance to a low enough value that allows enough electrosurgical energy through the tissue; to overcome the forces of expansion during tissue heating; and to contribute to the end tissue thickness which is an indication of a good seal. It has been determined that fused tissue is optimum between about 0.001 inches to about 0.006 inches for small vessels and tissues and about 0.004 inches to about 0.008 inches for large, soft tissue structures. Below these ranges, the seal may shred or tear and above this range the tissue may not be properly or effectively sealed.

It is thought that the process of coagulating or cauterizing small vessels is fundamentally different than electrosurgical vessel or tissue sealing. "Vessel sealing" or "tissue sealing" is defined as the process of liquefying the collagen, elastin and ground substances in the tissue so that it reforms into a fused mass with significantly-reduced demarcation between the opposing tissue structures. In contrast, the term "cauterization" is defined as the use of heat to destroy tissue (also called "diathermy" or "electrodiathermy") and the term "coagulation" is defined as a process of desiccating tissue wherein the tissue cells are ruptured and dried. Coagulation of small vessels is usually sufficient to

permanently close them, however, larger vessels or tissue need to be "sealed" to assure permanent closure.

Numerous electrosurgical instruments have been proposed in the past for various open and endoscopic surgical procedures. However, most of these instruments cauterize or coagulate tissue and are normally not designed to provide uniformly reproducible pressure on the blood vessel or tissue which, if used for sealing purposes, would result in an ineffective or non-uniform seal. For example, U.S. Patent No. 2,176,479 to Willis, U.S. Patent Nos. 4,005,714 and 4,031,898 to Hildebrandt, U.S. Patent Nos. 5,827,274, 5,290,287 and 5,312,433 to Boebel et al., U.S. Patent Nos. 4,370,980, 4,552,143, 5,026,370 and 5,116,332 to Lottick, U.S. Patent No. 5,443,463 to Stern et al., U.S. Patent No. 5,484,436 to Eggers et al. and U.S. Patent No. 5,951,549 to Richardson et al., all relate to electrosurgical instruments for coagulating, cauterizing, and cutting vessels or tissue.

Many of these instruments include blade members or shearing members which simply cut tissue in a mechanical and/or electromechanical manner and are relatively ineffective for vessel or tissue sealing purposes. Other instruments generally rely on clamping pressure alone to procure proper sealing thickness and are often not designed to take into account gap tolerances and/or parallelism and flatness requirements which are parameters which, if properly controlled, can assure a consistent and effective tissue seal. For example, it is known that it is difficult to adequately control thickness of the resulting sealed tissue by controlling clamping pressure alone for either of two reasons: 1) if too much force is applied, there is a possibility that the two poles will touch and energy will not be transferred through the tissue resulting in an ineffective seal; or 2) if too low a force is applied, a thicker less reliable seal is created.

Thus, a need exists to develop an electrosurgical instrument which effectively and consistently seals tissue and solves the aforementioned problems. This instrument should be designed to regulate the gap distances between opposing jaws members to procure a consistent and effective seal. Preferably, the instrument should also be designed to reduce the chances of the opposing jaws short circuiting during activation and assist in manipulating, gripping and holding the tissue prior to and during electrosurgical activation.

SUMMARY

The present disclosure relates to a bipolar forceps for sealing tissue which includes an elongated shaft having opposing jaw members at a distal end thereof and electrically conductive sealing surfaces attached to each jaw member. The jaw members are movable relative to one another from a first position wherein the electrically conductive sealing surfaces are disposed in spaced relation relative to one another to a second position wherein the electrically conductive sealing surfaces of the jaw members cooperate to grasp tissue therebetween. The electrically conductive sealing surfaces are adapted to connect to a source of electrical energy such that the electrically conductive sealing surfaces are capable of conducting energy through tissue held therebetween to effect a tissue seal. The forceps also includes a stop member assembly having at least one non-conductive stop member which is selectively adjustable to regulate the gap distance between

the opposing electrically conductive sealing surfaces when tissue is held therebetween.

Preferably, the stop member assembly includes at least one controller which is engagable with the stop member and which is configured to extend and retract the stop member in response to a signal from a control source, e.g., an electro-surgical generator. In one embodiment, the forceps includes a sensor disposed on one of the jaw members. Preferably, the sensor is configured to sense information relating to tissue impedance, tissue thickness and/or tissue type. The sensor relays the sensed information to the control source which, in turn, sends a signal to the controller for adjusting the stop member.

In one embodiment, the stop member assembly utilizes a set of gears to selectively extend and retract the stop member. In another embodiment, the stop member assembly utilizes a cam (or series of cams) to regulate the distance the stop member extends from the electrically conductive sealing surface. Other mechanisms are also envisioned, e.g., electro-mechanical actuators, ferroelectric actuators, piezo-electric actuators, piezo-ceramic actuators, hydraulics actuators, pneumatics actuators, magnetostrictors and rotational actuators.

Preferably, the stop member is selectively extendible in the range of about 0.001 inches to about 0008 inches from the electrically conductive sealing surface of at least one jaw member. The stop member may be extendible from one or both jaw members and may be manufactured from materials selected from

polyethylene, nylon and ceramic. The stop member may be adjusted either prior to or during activation. For example, the stop member may be automatically adjusted based upon a pre-surgical condition or tissue type and/or may be automatically adjustable based upon a surgical condition during activation, e.g., tissue impedance, tissue clarity, tissue moisture content, etc. Automatically adjusting the stop member during activation may create better results for large or thick tissues (e.g., liver) or ridged tissue (e.g., bronchus).

The present disclosure also relates to a method of sealing tissue comprising the steps of:

providing a bipolar forceps which includes a shaft having opposing jaw members at a distal end thereof. Each of the jaw members including an electrically conductive sealing surface which cooperate to grasp tissue therebetween. The forceps also includes at least one non-conductive stop member disposed on an electrically conductive surface of at least one of the jaw members. The non-conductive stop member is selectively adjustable to regulate the distance between the electrically conductive sealing surfaces when tissue is held therebetween.

The method also includes the steps of: connecting the electrically conductive sealing surfaces to a source of electrosurgical energy; adjusting the distance that the stop members extend from the electrically conductive sealing surface depending upon a pre-surgical condition; actuating the jaw members to grasp tissue between opposing electrically conductive sealing surfaces; and conducting energy to the electrically conductive sealing surfaces through tissue held

therebetween to effect a seal. The method of sealing tissue may further include the step of severing the tissue along the tissue seal. Additional steps may also be included for automatically adjusting the stop members based upon a pre-surgical condition or sensed surgical condition during surgery as described above.

In another method of sealing tissue according to the present disclosure, the adjusting step further includes the steps of: sensing a pre-surgical condition; and signaling the controller to selectively adjust the stop members relative to the electrically conductive sealing surface depending upon the sensed pre-surgical condition.

Another method according to the present disclosure includes the steps of: providing a bipolar forceps which includes a shaft having opposing jaw members at a distal end thereof which cooperate to grasp tissue therebetween, each of the jaw members including an electrically conductive sealing surface; at least one non-conductive stop member operatively associated with at least one electrically conductive surface of at least one of the jaw members, the non-conductive stop member being selectively adjustable to regulate the distance between the electrically conductive surfaces when tissue is held therebetween.

The method also includes the steps of: connecting the jaw members to a source of electrosurgical energy; actuating the jaw members to grasp tissue between opposing jaw members; conducting energy to the jaw members through tissue held therebetween to effect a tissue seal; and adjusting the distance that the

stop members extend from the electrically conductive sealing surface depending upon a sensed surgical condition during activation.

Preferably, the adjusting step further includes the step of: communicating with a feedback control system which continually senses surgical conditions during activation to automatically regulate the distance that the stop members extend from the electrically conductive sealing surfaces. The adjusting step may also include the step of: communicating with a feedback control system to automatically regulate the distance that the stop members extend from the electrically conductive sealing surfaces based upon at least one of tissue impedance, tissue temperature, tissue thickness, tissue moisture, tissue compliance or tissue clarity during activation.

BRIEF DESCRIPTION OF THE DRAWINGS

Various embodiments of the present disclosure are described herein with reference to the drawings wherein:

Fig. 1A is a perspective view of an endoscopic bipolar forceps which is configured to support a variable stop member assembly according to the present disclosure;

Fig. 1B is a side, partial internal view of an endoscopic forceps showing a selectively adjustable stop member assembly according to the present disclosure;

Fig. 1C is an enlarged view of the area of detail of Fig. 1B;

Fig. 2 is a side, partial internal view of an end effector assembly shown in closed configuration;

Fig. 3 is a rear, perspective view of the end effector of Fig. 2 shown with tissue grasped therein; and

Fig. 4 is an enlarged, perspective view of an electrically conductive sealing surface of the end effector assembly showing a series of selectively adjustable stop members disposed thereon.

DETAILED DESCRIPTION

Referring now to Figs. 1A - 4, an endoscopic bipolar forceps 10 is shown by way of example for use with various endoscopic surgical procedures. Either an endoscopic instrument or an open instrument may be utilized for supporting the variable stop member assembly according to the present disclosure. Obviously, different electrical and mechanical connections and considerations apply to each particular type of instrument, however, the novel aspects with respect to the stop member assembly and its operating characteristics remain generally consistent with respect to both the open or endoscopic designs. Forceps 10 is shown by way of example and other electrosurgical forceps are also envisioned which may support the stop member assembly of the present disclosure. In the drawings and in the description which follows, the term "proximal", as is traditional, will refer to the end of

the forceps 10 which is closer to the user, while the term "distal" will refer to the end of the forceps which is further from the user.

Figs. 1A - 1C show an endoscopic vessel sealing forceps 10 which is configured to support an electrode sealing assembly 100. More particularly, forceps 10 generally includes a housing 20, a handle assembly 30, a rotating assembly 80, a trigger assembly 70 and the end effector assembly 100 which mutually cooperate to grasp, seal and, if warranted, divide tissue. The forceps 10 includes a shaft 12 which has a distal end 14 dimensioned to mechanically engage the end effector assembly 100 and a proximal end 16 which mechanically engages the housing 20 proximate the rotating assembly 80.

Forceps 10 also includes a plug (not shown) which connects the forceps 10 to a source of electrosurgical energy, e.g., an electrosurgical generator 500, via an electrical cable 310. Handle assembly 30 includes a fixed handle 50 and a movable handle 40. Handle 40 moves relative to fixed handle 50 to actuate the end effector assembly 100 and enable a user to grasp and manipulate tissue 400 (See Fig. 3). The end effector assembly 100 includes a pair of opposing jaw members 110 and 120 which each have an electrically conductive sealing surface 112 and 122, respectively, attached thereto for conducting electrosurgical energy through tissue 400 held therebetween. More particularly, the jaw members 110 and 120 move in response to movement of the handle 40 from an open position wherein the electrically conductive sealing surfaces 112 and 122 are disposed in spaced relation relative to one another, to a clamping or closed position wherein the

electrically conductive sealing surfaces 112 and 122 cooperate to grasp tissue therebetween.

The housing 20 encloses a drive assembly (not shown) which cooperates with the movable handle 40 to impart movement of the jaw members 110 and 120 from the open position to the clamping or closed position. One Example of a handle assembly is shown and described in commonly-owned U.S. Application Serial No. 10/389,894 entitled "VESSEL SEALER AND DIVIDER AND METHOD MANUFACTURING SAME" which is hereby incorporated by reference herein in its entirety. The handle assembly of this particular disclosure is generally be characterized as a four-bar mechanical linkage which provides a unique mechanical advantage when sealing tissue between the jaw members 110 and 120. For example, once the desired position for the sealing site is determined and the jaw members 110 and 120 are properly positioned, handle 40 may be compressed fully to lock the electrically conductive sealing surfaces 112 and 122 in a closed position against the tissue. The details relating to the inter-cooperative relationships of the inner-working components of forceps 10 are disclosed in the above-cited commonly-owned U.S. Patent Application No. 10/369,894. When the electrically conductive sealing surfaces 112 and 122 of the jaw members 110 and 120 are fully compressed about the tissue 400, the forceps 10 is now ready for selective application of electrosurgical energy (See Fig. 3). Another example of an endoscopic handle assembly is disclosed in U.S. Patent Application Serial No. 10/460,926 entitled "VESSEL SEALER AND DIVIDER FOR USE WITH SMALL TROCARS AND

CANNULAS", the entire contents of this application being incorporated by reference herein.

Experimental results suggest that the magnitude of pressure exerted on the tissue 400 by the electrically conductive sealing surfaces 112 and 122 is important in assuring a proper surgical seal. Pressures within a working range of about 3 kg/cm² to about 16 kg/cm² and, preferably, within a working range of about 7 kg/cm² to about 13 kg/cm² have been shown to be effective for sealing various small tissue types. Pressure within a working range of about 4.5 kg/cm² to about 8.5 kg/cm² are optimal for large soft tissue structures.

As explained above, movement of the handle assembly 30, e.g., via a four-bar linkage, ultimately causes the opposing jaw members 110 and 120 to move relative to one another. As can be appreciated, the significant mechanical advantage associated with the four-bar linkage permits facile, consistent and uniform compression of the jaw members 110 and 120 about the tissue 400. Other details and advantages of the four-bar mechanical linkage are more fully discussed with respect to the above-mentioned commonly-owned U.S. Patent Application No. 10/369,894.

As best seen in Figs. 1A -1C, forceps 10 also includes a trigger 70 which advances a knife 200 disposed within the end effector assembly 100. Once a tissue seal is formed, the user can activate the trigger 70 to separate the tissue 400 along the tissue seal. Knife 200 preferably includes a sharpened edge 205 for

severing the tissue 400 held between the jaw members 110 and 120 at the tissue sealing site.

A rotating assembly 80 may also be incorporated with forceps 10. Preferably, rotating assembly 80 is mechanically associated with the shaft 12 and the drive assembly (not shown). Movement of the rotating assembly 80 imparts similar rotational movement to the shaft 12 which, in turn, rotates the end effector assembly 100. These features along with the unique electrical configuration for the transference of electrosurgical energy through the handle assembly 20 and the rotating assembly 80 are described in more detail in the above-mentioned commonly-owned U.S. Patent Application Nos. 10/369,894 and 10/460,926.

As best seen with respect to Figs. 1A - 2, end effector assembly 100 attaches to the distal end 14 of shaft 12. The jaw members 110 and 120 are preferably pivotable about a pivot 160 from the open to closed positions upon relative reciprocation, i.e., longitudinal movement, of the drive assembly (not shown). Again, mechanical and cooperative relationships with respect to the various moving elements of the end effector assembly 100 are further described by example with respect to the above-mentioned commonly-owned U.S. Patent Application Nos. 10/369,894 and 10/460,926.

It is envisioned that the forceps 10 may be designed such that it is fully or partially disposable depending upon a particular purpose or to achieve a particular result. For example, end effector assembly 100 may be selectively and releasably

engageable with the distal end 14 of the shaft 12 and/or the proximal end 16 of the shaft 12 may be selectively and releasably engageable with the housing 20 and handle assembly 30. In either of these two instances, the forceps 10 would be considered "partially disposable" or "reposable", i.e., a new or different end effector assembly 100 (or end effector assembly 100 and shaft 12) selectively replaces the old end effector assembly 100 as needed.

Each of the jaw members 110 and 120 includes an electrically conductive sealing surface 112 and 122, respectively disposed on an inner-facing surface thereof. It is envisioned that the electrically conductive surfaces 112 and 122 cooperate to seal tissue 400 held therebetween upon the application of electrosurgical energy. Insulators 116 and 126 (together with the outer, non-conductive surfaces of the jaw members 110 and 120) may be included to limit and/or reduce many of the known undesirable effects related to tissue sealing, e.g., flashover, thermal spread and stray current dissipation (See Fig. 1C).

Preferably, a least one of the electrically conductive surfaces, e.g., 112, of one of the jaw members, e.g., 110, includes a longitudinally-oriented channel 210 defined therein (See Fig. 4) which extends from the proximal end of the electrically conductive sealing surface 112 to the distal end. The channel 210 facilitates longitudinal reciprocation of the knife 200 along a preferred cutting plane to effectively and accurately separate the tissue 400 along a formed tissue seal.

By controlling the intensity, frequency and duration of the electrosurgical energy applied to the tissue 400, the user can selectively seal tissue 400. As mentioned above, two mechanical factors play an important role in determining the resulting thickness of the sealed tissue and effectiveness of the seal, i.e., the pressure applied between opposing jaw members 110 and 120 and the gap distance "G" between the opposing sealing surfaces 112 and 122 of the jaw members 110 and 120, respectively, during the sealing process.

However, thickness of the resulting tissue seal cannot be adequately controlled by force alone. In other words, too much force and the two jaw members 110 and 120 would touch and possibly short resulting in little energy traveling through the tissue 400 thus resulting in a bad tissue seal. Too little force and the seal would be too thick. Applying the correct force is also important for other reasons: to reduce the tissue impedance to a low enough value that allows enough current through the tissue 400; and to overcome the forces of expansion during tissue heating in addition to contributing towards creating the required end tissue thickness which is an indication of a good seal.

In order to achieve a desired spacing between the electrically conductive surfaces 112 and 122 of the respective jaw members 110 and 120, (i.e., gap distance "G") and apply a desired force to seal the tissue 400, at least one jaw member 110 and/or 120 includes at least one stop member, e.g., 150, to limit the movement of the two opposing jaw members 110 and 120 relative to one another. Preferably, the stop member, e.g., 150, extends from at least one of the sealing

surfaces 112, 122 a predetermined distance according to the specific material properties of the stop member 150 (e.g., compressive strength, thermal expansion, etc.) to yield a consistent and accurate gap distance "G" during sealing. Preferably, the gap distance "G" between opposing sealing surfaces 112 and 122 during sealing ranges from about 0.001 inches to about 0.008 inches. Preferably for smaller tissue types the gap distance is optimal between about 0.002 inches to about 0.003 inches and for larger tissue types the gap distance is optimal between about 0.004 inches to about 0.007 inches.

Preferably, stop members 150 are made from an insulative material, e.g., parylene, nylon and/or ceramic and are dimensioned to limit opposing movement of the electrically conductive sealing surfaces 112 and 122 to within the above mentioned gap range "G". It is envisioned that the stop members 150 may be disposed on one or both of the electrically conductive sealing surfaces 112 and 122 depending upon a particular purpose or to achieve a particular result.

As best shown in Figs. 1B and 1C, at least of the jaw members includes a selectively adjustable stop member assembly 140 which allows a surgeon to regulate the gap distance "G" depending upon a particular tissue type and/or tissue thickness. More particularly, at least one of the jaw members, e.g., jaw member 110, includes a cavity 130 disposed therein which is dimensioned to house the stop member assembly 140. Stop member assembly 140 includes a plurality of selectively adjustable stop member control units 145 which includes a stop member 150 and a controller 155. More particularly, the controller 155 is designed to receive

signals from a control source 300 (Fig. 2) which may be attached to an electrosurgical generator 500 or incorporated into the housing of the forceps 10. The control source 300 signals the controller 155 to electrically, mechanically or electro-mechanically adjust the distance the stop member(s) 150 projects or extends from the electrically conductive sealing surface 112 (and/or 122). The distance that the stop member(s) 150 projects from the electrically conductive sealing surface 112 (and/or 122) determines the ultimate gap distance "G" (See Fig. 2).

It is envisioned that the controller 155 may adjust the distance that each stop member 150 extends from the sealing surface 112 in any known fashion. For example, each stop member 150 and its corresponding controller 155 may be threadably connected such that the controller 155 "unscrews" the stop member 150 to adjust the distance that the stop member 150 extends from the sealing surface 112. Thus, by controlling the amount that the stop member 150 unscrews from the controller 155, a surgeon can selectively regulate (or a control source 300 may automatically regulate) the gap distance "G". Other mechanical systems (not shown) are also envisioned to allow selective regulation of the gap distance "G", e.g., gearing mechanisms, camming mechanisms, pneumatic mechanisms, hydraulic mechanisms, etc. Electromechanical systems are also contemplated, e.g., electro-mechanical actuators, ferroelectric actuators, piezo-electric actuators, piezo-ceramic actuators, magnetostrictors and rotational actuators, etc.

It is envisioned that the controller 155 may cooperate with a sensor assembly 170a and 170b (or a plurality of sensors) which determines or measures

tissue thickness, tissue moisture, tissue type, tissue impedance, etc. and automatically signals the control source 300 to signal the controller 155 to adjust the stop members 150 to extend a specific distance (i.e., a "preferred" or "recommended" gap distance "G") from the electrically conductive sealing surface 112 prior to activation. The preferred gap distance "G" (which directly corresponds to the specified distance that the stop members 150 extend from the electrically conductive sealing surface 112) may be selected from a look-up table or determined by a computer algorithm stored within the control source 300. It is envisioned that the stop members are selectively adjustable to protrude about 0.001 inches to about 0.008 inches from the electrically conductive sealing surfaces 112 (and/or 122) of the jaw members 110 (and/or 120).

It is also contemplated that one or more stop members 150 may be individually controllable (via controller 155 or manually) to vary the gap distance along or across the sealing surfaces depending upon a particular purpose or to achieve a particular tissue seal. Moreover, it is envisioned that varying the distance that stop member(s) project from the sealing surface(s) may produce different results for different tissue types and may prove desirable for one or more particular tissue types or one or more different surgical procedures.

The sensors 170a and 170b are connected to the control source 300 (or electrosurgical generator) via cables 171a and 171b, respectively. The sensors 170a and 170b may form a part of a closed-loop control system which automatically adjusts the forceps 10 prior to and/or during activation based on pre-surgical

parameters and continually-sensed parameters. For example, the stop members 150 may be adjusted based upon a pre-surgical parameter such as tissue thickness, tissue type, tissue compliance, tissue impedance, etc. One example of a closed-loop control system is described in commonly-owned U.S. Patent Application Serial No. 10/427,832 filed on May 1, 2003 entitled "METHOD AND SYSTEM FOR CONTROLLING OUTPUT OF RF MEDICAL GENERATOR" the entire contents of which are hereby incorporated by reference herein. For example, the stop member(s) 150 may be set according to a pre-surgical condition (either automatically based upon a sensed condition (e.g., tissue impedance, tissue type, tissue clarity, tissue compliance, etc.)) or manually by the surgeon.

It is also envisioned that the stop member(s) 150 may be adjusted during activation based upon a continually-sensed surgical condition (e.g., tissue impedance, tissue type, tissue clarity, tissue compliance, etc.) utilizing a feed back control loop. It is envisioned that this may allow the control system to achieve a "slow close" condition. More particularly, one preferred technique for sealing larger tissue structures (e.g., lung, liver, bronchus, etc.) is a so-called "slow-close" surgical technique which involves activating the surgical instrument prior to obtaining a fully ratcheted position. As can be appreciated, this type of procedure is very difficult to master manually due to the many variables involved with the sealing process and, as a result, the instrument may short or the sealing cycle may complete prior to obtaining the fully closed ratcheted position. It is envisioned that the automatic stop member adjustment system described above may enable slow close activation which may lead to more effective sealing of large tissue structures. For example,

the surgeon can grasp the tissue in a customary manner and fully ratchet the forceps about the tissue within the preferred pressure ranges. The stop member(s) 150 can be programmed to activate in a "slow close" manner and automatically adjust from a large gap distance e.g., about 0.10 inches to within a preferred gap range of about 0.001 inches to about 0.008 inches during activation. The stop member control assembly 140 may also be coupled to a feedback control system which automatically regulates the "slow close" technique based upon tissue thickness, tissue temperature, tissue impedance, tissue moisture, tissue clarity, tissue compliance during activation. As can be appreciated, this enables any surgeon to perform a slow close technique for sealing larger tissue structures.

A control knob 350 (See Fig. 2) may also be included to permit a surgeon to manually adjust the distance that the stop members 150 protrude from the electrically conductive sealing surface 112 (and/or 122) depending upon a particular purpose.

Fig. 4 shows one contemplated configuration of the stop members 150 disposed on or protruding from the electrically conductive sealing surface 112. It is envisioned that the stop members 150 can be positioned on either or both jaw members 110 and 120 depending upon a particular purpose or to achieve a desired result. More particularly and as illustrated in Fig. 4, a series of longitudinally-oriented tab-like stop members 150 are disposed along either side of the knife channel 210 of jaw member 110. Preferably, the stop members 150 may be configured in any known geometric or polynomial configuration, e.g., triangular, rectilinear, circular,

ovoid, scalloped, etc., depending upon a particular purpose. Moreover, it is contemplated that any combination of different stop members 150 may be assembled along the sealing surfaces 112 (and/or 122) to achieve a desired gap distance "G". A ceramic or insulative coating may be deposited or sprayed onto the tissue engaging surface of the stop members 150. Thermal spraying techniques are contemplated which involve depositing a broad range of heat resistant and insulative materials on the tissue engaging surfaces of the stop members 150, high velocity Oxy-fuel deposition, plasma deposition, etc.

Further, although it is preferable that the stop members 150 are selectively adjustable to protrude about 0.001 inches to about 0.008 inches from the electrically conductive sealing surfaces 112, in some cases it may be preferable to have the stop members 150 protrude more or less depending upon a particular purpose. For example, it is contemplated that the type of material used for the stop members 150 and that material's ability to absorb the preferred range of compressive closure forces between jaw members 110 and 120 will vary and, therefore, the overall distance that the stop members 150 may have to extend from the electrically conductive sealing surfaces 112 may have to be adjusted to compensate for the particular stop member 150 material being utilized to produce the desired gap distance "G".

In other words, the compressive strength of the stop member material along with the desired or ultimate gap distance "G" required for effective sealing are parameters which should be considered during activation since one material may

have to be adjusted differently from another material to achieve the same gap distance "G". For example, the compressive strength of nylon is different from ceramic and, therefore, the nylon material may have to extend a greater distance from the electrically conductive sealing surface 112 to counteract the closing force of the opposing jaw members 110 and 120 and to achieve the same desired gap distance "G". As can be appreciated, these considerations may be automatically regulated or controlled at the control source 300 via a computer algorithm or look up table.

The present disclosure also relates to a method of sealing tissue utilizing a selectively adjustable stop member 150 and includes the steps of: providing a bipolar forceps 10 having a shaft 12 and opposing jaw members 110 and 120 which cooperate to grasp tissue 400 therebetween; at least one selectively extendible and non-conductive stop member 150 disposed on an electrically conductive surface 112 of at least one of the jaw members, e.g., 110, which regulates the distance between the jaw members 110 and 120 when tissue 400 is held therebetween. The method further includes the steps of: connecting the electrically conductive sealing surfaces 112 and 122 of the jaw members 110 and 120 to a source of electrosurgical energy; adjusting the distance that the stop members 150 extend from the electrically conductive sealing surface 112 depending upon a pre-surgical condition or parameter; actuating the jaw members 110 and 120 to grasp tissue 400 between opposing electrically conductive sealing surfaces 112 and 122; conducting energy to the electrically conductive sealing surfaces 112 and 122 through tissue 400 held therebetween to effect a seal.

The adjusting step of the method may further include the steps of: sensing a pre-surgical condition or parameter such as tissue type, tissue thickness, tissue compliance, tissue impedance, etc. and signaling the controller 155 (via the control source 300 or directly) to selectively extend or retract the stop members 150 relative to the electrically conductive sealing surface 112 depending upon the sensed pre-surgical condition or parameter.

At least one of the jaw members, e.g., 110, of the providing step includes may include an electrically conductive sealing surface 112 having a longitudinally-oriented channel 210 defined therein which facilitates actuation of a knife 200 in a longitudinally reciprocating fashion within the channel 210 for severing the tissue 400 proximate the tissue sealing site. As can be appreciated, the method may also include the step of severing the tissue 400 along the tissue seal.

From the foregoing and with reference to the various figure drawings, those skilled in the art will appreciate that certain modifications can also be made to the present disclosure without departing from the scope of the same. For example, it may be preferable to add other features to the forceps 10, e.g., an articulating assembly to axially displace the end effector assembly 100 relative to the elongated shaft 12.

Moreover, it is contemplated that the presently disclosed forceps may include a disposable end effector assembly 100 which is selectively engageable with at least one portion of the electrosurgical instrument, e.g., shaft 12 and/or handle assembly 80. Preferably, the electrically conductive sealing surfaces 112 and 122

of the jaw members 110 and 120 are relatively flat to avoid current concentrations at sharp edges and to avoid arcing between high points. In addition and due to the reaction force of the tissue 400 when engaged, jaw members 110 and 120 are preferably manufactured to resist bending. For example, the jaw members 110 and 120 may be tapered along their respective widths which is advantageous for two reasons: 1) the taper will apply constant pressure for a constant tissue thickness at parallel; 2) the thicker proximal portion of the jaw members 110 and 120 will resist bending due to the reaction force of the tissue 400.

It is also contemplated that one or more stop members may be disposed adjacent to one or both electrically conductive sealing surfaces to regulate the gap distance between conductive surfaces. Alternatively, one or more selectively extendible stop members may be disposed on one or both electrically conductive sealing surface(s) and one or more stop members may be disposed adjacent to at least one of the electrically conductive surfaces. As can be appreciated, both sets of selectively adjustable stop members would cooperate with the controller (or manually) to adjust and regulate the gap distance.

The stop member(s) may be dimensioned in any known geometric configuration and may be disposed on or adjacent to one or both of the electrically conductive tissue sealing surfaces or operatively associated with one or both jaw members. Moreover, the controller and stop member may be integrally associated with one another or may be formed from two or more components so long as the stop member is selectively adjustable to regulate the distance between the jaw members prior to and/or during electrical activation.

While several embodiments of the disclosure have been shown in the drawings and/or discussed herein, it is not intended that the disclosure be limited thereto, as it is intended that the disclosure be as broad in scope as the art will allow and that the specification be read likewise. Therefore, the above description should not be construed as limiting, but merely as exemplifications of preferred embodiments. Those skilled in the art will envision other modifications within the scope and spirit of the claims appended hereto.

WHAT IS CLAIMED IS:

1. A bipolar forceps for sealing tissue, comprising:
 - an elongated shaft having opposing jaw members at a distal end thereof, each of the jaw members including an electrically conductive sealing surface affixed thereto, the jaw members being movable relative to one another from a first position wherein the electrically conductive sealing surfaces are disposed in spaced relation relative to one another to a second position wherein the electrically conductive sealing surfaces cooperate to grasp tissue therebetween;
 - each electrically conductive sealing surface adapted to be connected to a source of electrical energy such that the electrically conductive sealing surfaces are capable of conducting energy through tissue held therebetween to effect a tissue seal; and
 - a stop member assembly operatively associated with at least one jaw member, the stop member including at least one non-conductive stop member, the at least one stop member being selectively adjustable to regulate the distance between the electrically conductive sealing surfaces when tissue is held therebetween.

2. A bipolar forceps for sealing tissue according to claim 1 wherein the stop member assembly includes at least one controller which is engagable with the at least one stop member, the controller being configured to extend and retract the stop member in response to a signal from a control source.

3. A bipolar forceps for sealing tissue according to claim 2 wherein the forceps includes at least one sensor disposed on at least one of the jaw members, the at least one sensor being configured to sense information relating to at least one of tissue impedance, tissue thickness, tissue compliance and tissue type and relaying the sensed information to a control source which, in turn, sends a signal to the controller.
4. A bipolar forceps for sealing tissue according to claim 2 wherein the stop member assembly utilizes at least one gear to selectively extend and retract the stop member from the at least one electrically conductive sealing surface.
5. A bipolar forceps for sealing tissue according to claim 2 wherein the stop member assembly utilizes at least one cam to selectively extend and retract the stop member from the at least one electrically conductive sealing surface.
6. A bipolar forceps for sealing tissue according to claim 2 wherein the stop member assembly utilizes at least one actuator to selectively extend and retract the stop member from the at least one electrically conductive sealing surface, the actuator being selected from the group consisting of electro-mechanical actuators, ferroelectric actuators, piezo-electric actuators, piezo-ceramic actuators, hydraulics actuators, pneumatics actuators, magnetostrictors and rotational actuators.

7. A bipolar forceps for sealing tissue according to claim 1 wherein the stop member is manufactured from the group consisting of parylene, nylon and ceramic.
8. A bipolar forceps for sealing tissue according to claim 1 wherein the forceps includes a selectively extendible knife for severing tissue along the tissue seal.
9. A bipolar forceps for sealing tissue according to claim 1 wherein the at least one stop member is selectively extendible in the range of about 0.001 inches to about 0.008 inches from the electrically conductive sealing surface of at least one jaw member.
10. A bipolar forceps for sealing tissue according to claim 1 wherein the stop member is thermally sprayed onto the at least one electrically conductive sealing surface.
11. A bipolar forceps for sealing tissue according to claim 1 wherein a first selectively extendible stop member is operatively associated with one of the jaw members and at least one second selectively extendible stop member is operatively associated with the other jaw member.

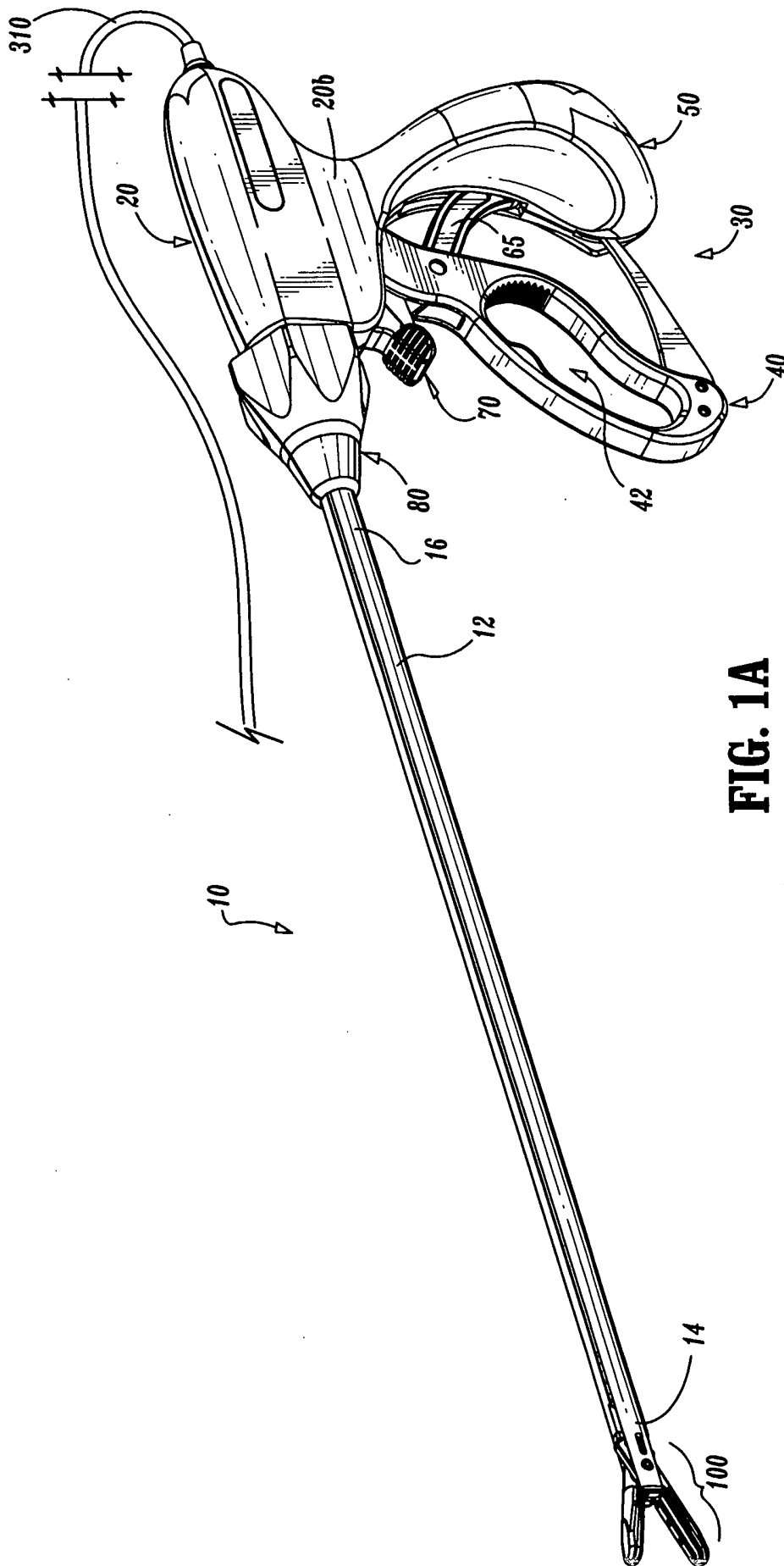

FIG. 1A

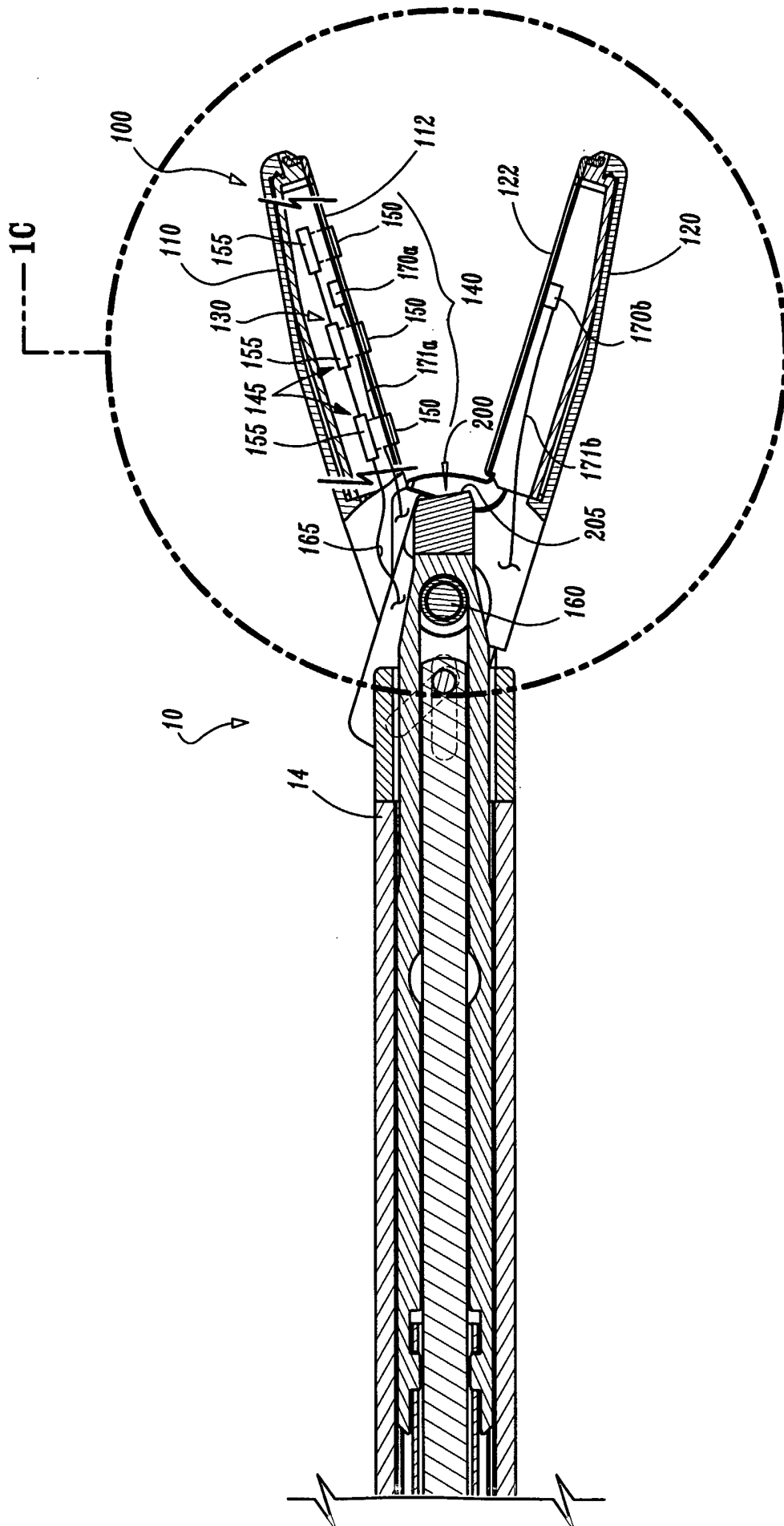

FIG. 1B

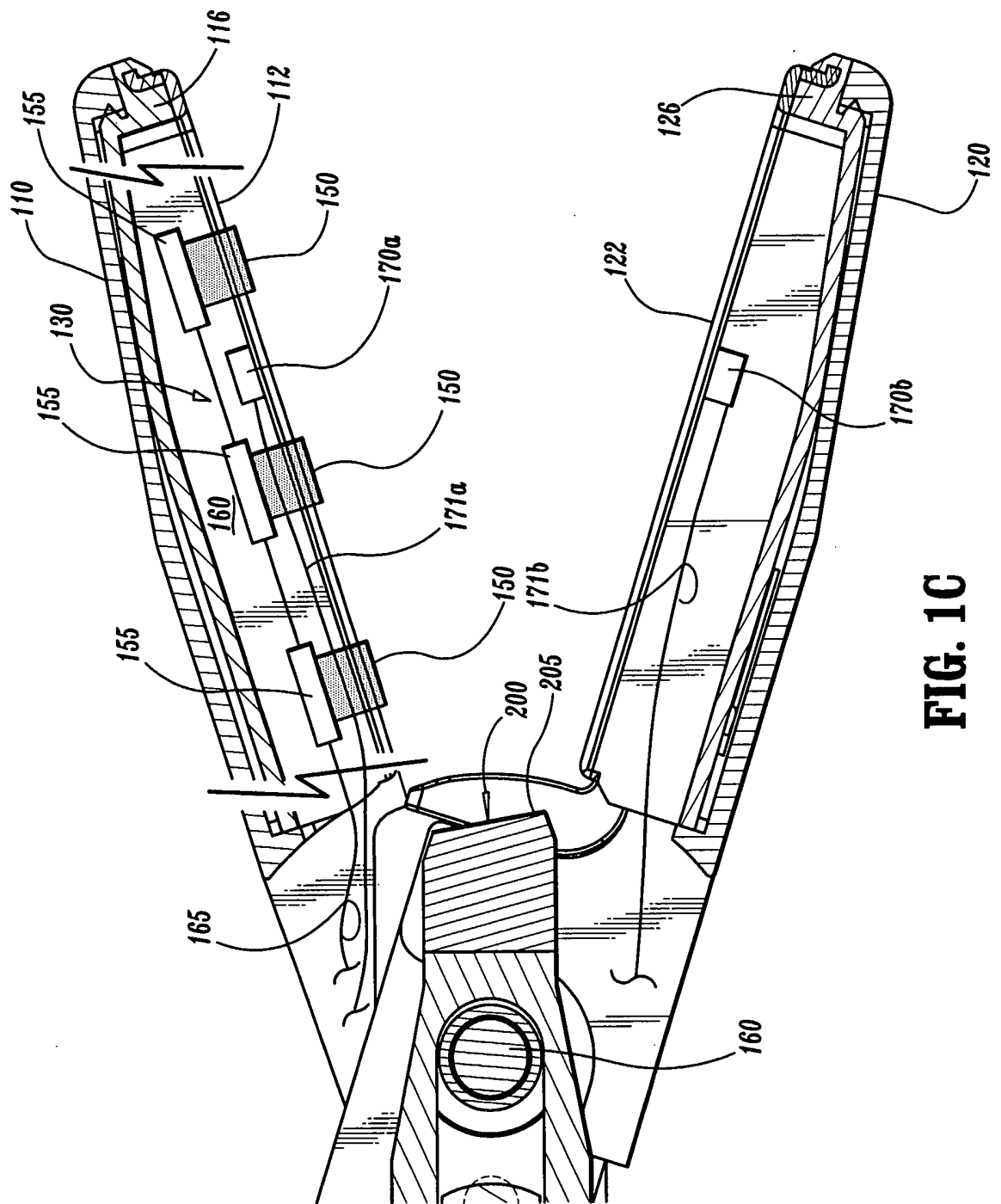

FIG. 1C

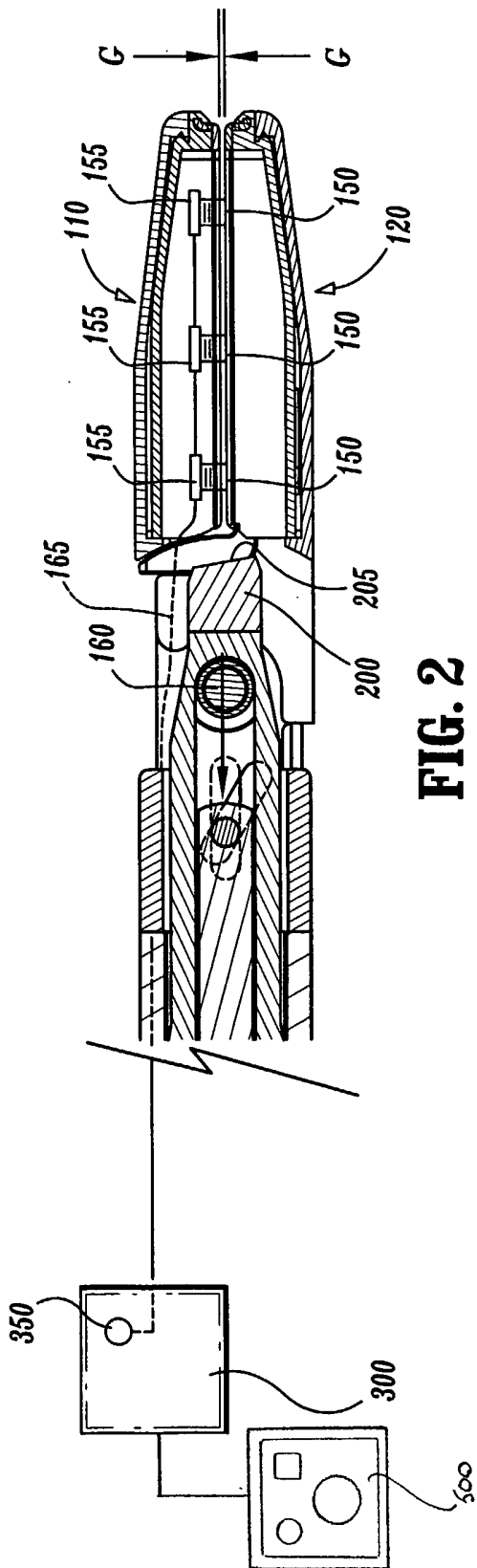

FIG. 2

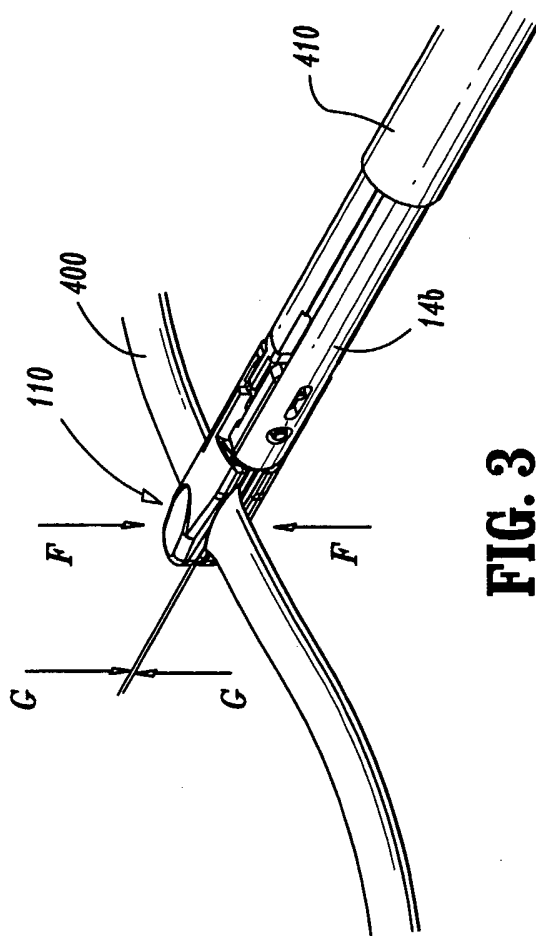

FIG. 3

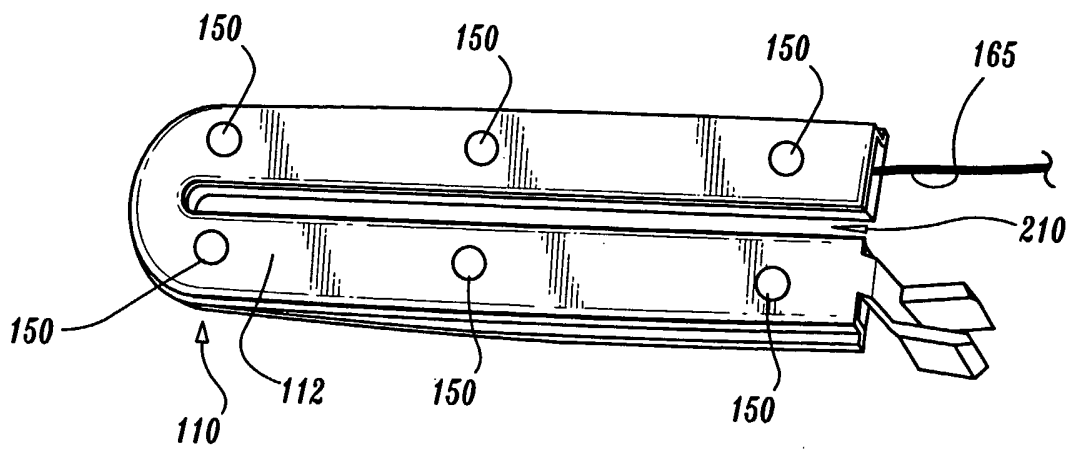

FIG. 4