

(Model.)

A. ASSORATI.
WRENCH.

No. 525,575.

Patented Sept. 4, 1894.

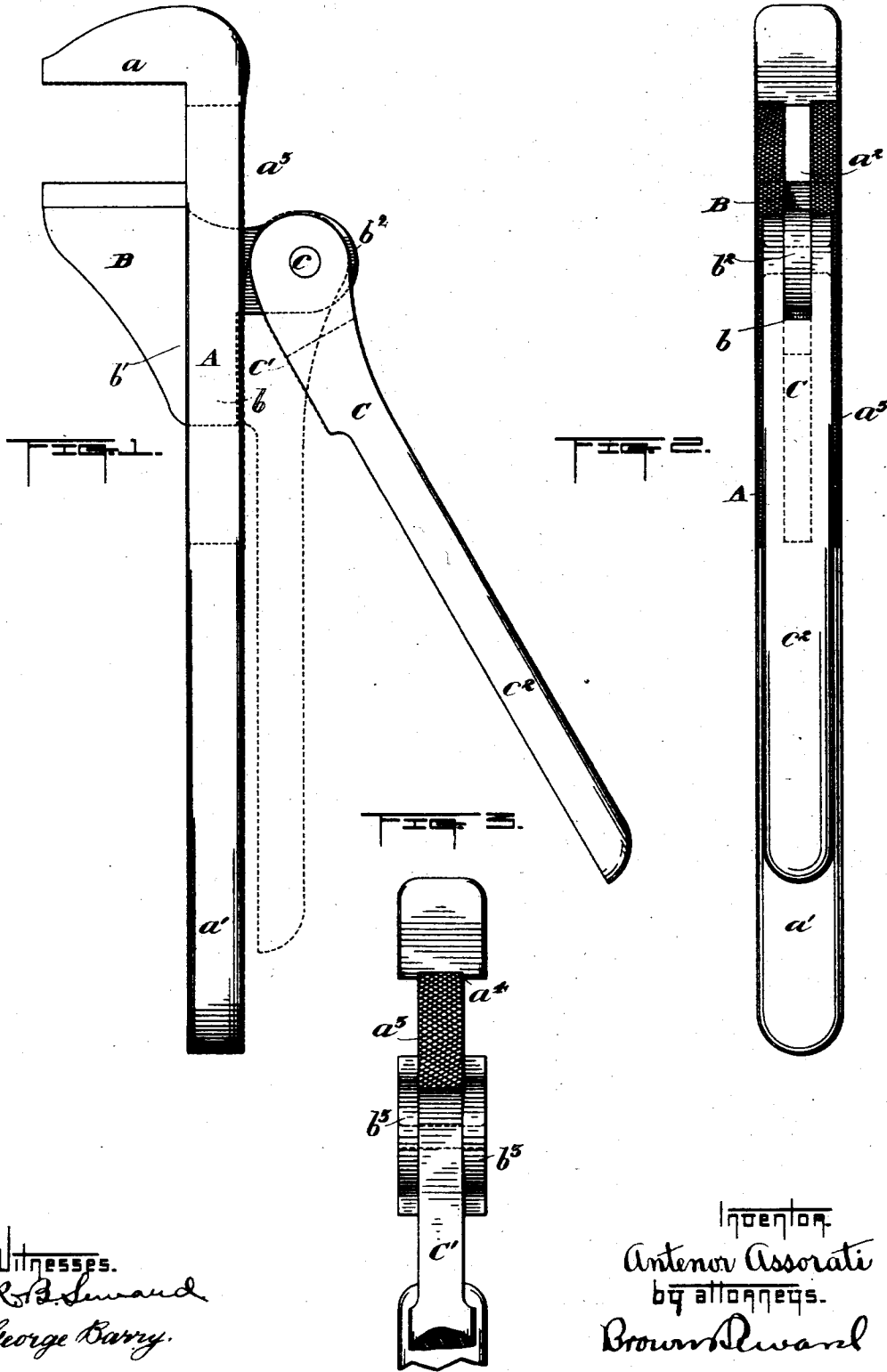

Witnesses.
R. B. Seward
George Barry.

Inventor
Antenor Assorati
by attorneys.
Brown Seward

UNITED STATES PATENT OFFICE.

ANTENOR ASSORATI, OF NEW YORK, N. Y., ASSIGNOR TO RAFAEL R. GOVIN,
OF SAME PLACE.

WRENCH.

SPECIFICATION forming part of Letters Patent No. 525,575, dated September 4, 1894.

Application filed December 5, 1893. Serial No. 492,810. (Model.)

To all whom it may concern:

Be it known that I, ANTENOR ASSORATI, a resident of New York, in the county and State of New York, have invented a new and useful Improvement in Wrenches, of which the following is a specification.

My invention relates to an improvement in wrenches in which a movable jaw is constructed to be slid along the shank toward and away from a stationary jaw to suit the part to be gripped, and to be temporarily locked in its adjusted position.

A practical embodiment of my invention is represented in the accompanying drawings, in which—

Figure 1 is a view of the wrench in side elevation, showing, in full lines, the position of the grip lever when in released adjustment and, in dotted lines, the position of the grip lever when in locked adjustment. Fig. 2 is a view of the wrench in back elevation, and Fig. 3 is a partial back view of a wrench, the sliding jaw being provided with a double web or tongue to embrace a reduced portion of the shank, as distinguished from a single web or tongue, to enter an elongated slot in the shank, as shown in Figs. 1 and 2.

A represents the shank of the wrench terminating at one end in a fixed jaw a and provided at the opposite end with a handle a' . The handle, jaw and shank may either be formed in one piece, or the handle or handle and jaw may be formed separately and fixed to the shank in any well known or approved manner. The fixed jaw a is herein represented as having a straight working face, but it is to be understood that it may be made to assume any well known or approved form as the uses to which the wrench is to be put may suggest.

In the form represented in Figs. 1 and 2, the shank A is provided with an elongated slot a^2 extending through the shank from front to rear.

The movable jaw is denoted by B and has a web or tongue b extending rearwardly from its back face and adapted to enter the slot a^2 in the shank with an easy sliding fit. The jaw B is provided with shoulders b' which, when the jaw is in working position, abut against the front of the shank upon opposite

sides of the slot a^2 . A portion b^3 of the tongue or web b projects through the slot at the back of the shank A and is provided with a transverse perforation to receive the pivot, pin or rivet c which secures the grip lever C to the movable jaw.

The grip lever C has a roughened grip face c' and a handle c^2 which, when the grip face c' is brought into contact with the roughened surface a^3 at the back of the shank, extends along the back of the handle a' in position to be readily grasped by the same hand that grasps the handle of the wrench. The grip face c' of the grip lever is preferably arranged to have an extended area of bearing against the back of the shank to insure a perfect locking of the movable jaw without requiring an undue amount of pressure on the handle of the lever.

In the form shown in Fig. 3, the shank is cut away upon its opposite sides, as shown at a^4 , and the movable jaw is provided with a pair of webs or tongues b^3 adapted to receive between them the reduced portion of the shank. The head of the grip lever C' is, like the head of the grip lever C already referred to, pivoted to backwardly projecting portions of the webs or tongues, in the form shown in Fig. 3, by being inserted between them, while, in the form shown in Figs. 1 and 2, by embracing the opposite sides of the web or tongue.

In practice, the wrench is placed with its jaws upon opposite sides of the pipe, nut or other part to be operated upon and the movable jaw slid up into close contact with said part. The grip lever is then pressed toward the handle a' , bringing its gripping face into contact with the back of the shank and thereby drawing the shoulders b' of the movable jaw into snug contact with the shank and locking the jaw against displacement so long as the pressure is maintained upon the grip lever.

It will be observed that the adjustments of the movable jaw may be made with great celerity and with exactness, since the grip lever will hold the movable jaw in adjustments which do not vary even a hair's breadth from one another, throughout the sliding movement of the jaw. It will also be observed that

the wrench consists of very few parts and these of simple structure.

What I claim is—

1. A wrench, comprising a stationary jaw, 5 a movable jaw arranged to slide toward and away from the stationary jaw and a grip lever pivoted to the movable jaw in position to draw the movable jaw toward the shank to which the stationary jaw is fixed, the handle of the 10 grip lever extending along down the handle of the wrench in position to be grasped by the same hand that grasps the handle of the wrench, and the movable jaw being free to be slid in either direction along the shank of the 15 wrench when the grip lever is released from pressure, without removing it from within the grasp of the hand, substantially as set forth.
2. A wrench, comprising a sliding shank 20 jaw having a web or tongue extended through

the slotted shank and the grip lever pivoted to the projecting end of the web or tongue in position to engage the shank when its handle is pressed toward the handle of the wrench, the engaging faces of the shank and grip lever, 25 being roughened, the handle of the grip lever being extended along the handle of the wrench into position to be grasped by the same hand that grasps the wrench handle and the roughened faces of the grip and wrench 30 being such as to admit of the free sliding movement of the movable jaw along the shank of the wrench in either direction without removing the handle of the grip from the hand which grasps both it and the wrench handle, 35 substantially as set forth.

ANTENOR ASSORATI.

Witnesses:

FREDK. HAYNES,
GEORGE BARRY.