



US006998044B2

(12) **United States Patent**  
**Jangbarwala**

(10) **Patent No.:** **US 6,998,044 B2**  
(45) **Date of Patent:** **Feb. 14, 2006**

(54) **ELECTROPHORETIC CROSS-FLOW  
FILTRATION AND  
ELECTRODEIONIZATION: METHOD FOR  
TREATING EFFLUENT WASTE AND  
APPARATUS FOR USE THEREWITH**

(58) **Field of Classification Search** ..... 210/243,  
210/259, 264, 266, 295, 321.78, 321.87,  
210/638, 639, 650-652, 669, 670, 748, 805,  
210/806, 283, 284; 204/524-533, 630-640  
See application file for complete search history.

(75) **Inventor:** **Juzer Jangbarwala**, Chino Hill, CA  
(US)

(56) **References Cited**

(73) **Assignee:** **The BOC Group, Inc.**, Murray Hill,  
NJ (US)

U.S. PATENT DOCUMENTS

(\* ) **Notice:** Subject to any disclaimer, the term of this  
patent is extended or adjusted under 35  
U.S.C. 154(b) by 128 days.

2,815,320 A \* 12/1957 Kollsman ..... 204/524  
2,854,394 A \* 9/1958 Kollsman ..... 204/524  
3,149,061 A \* 9/1964 Parsi ..... 204/517

(Continued)

(21) **Appl. No.:** **10/380,581**

*Primary Examiner*—Joseph Drodge

(22) **PCT Filed:** **Sep. 14, 2001**

(74) *Attorney, Agent, or Firm*—David A. Hey

(86) **PCT No.:** **PCT/US01/28737**

§ 371 (c)(1),  
(2), (4) **Date:** **May 5, 2003**

(57) **ABSTRACT**

(87) **PCT Pub. No.:** **WO02/22511**

**PCT Pub. Date:** **Mar. 21, 2002**

The present invention provides a method and apparatus for purifying effluent wastewater utilizing electrophoretic cross-flow filtration and electrodeionization. The method first comprises filtering the water in a cross-flow direction with a filter membrane (120) in the presence of an electric field that is operative to drive suspended particles away from a surface of the filter membrane (120). The permeate (134) containing dissolved solids is next passed through a mixture (188) of at least one cation-exchange resin and at least one anion-exchange resin disposed between a cation-selective membrane (184) and an anion-selective membrane (181) in the presence of an electric field. The electric field drives cations in the permeate through the cation-selective membrane (184), and drives anions in the permeate through the anion-selective membrane (181), thereby to form deionized water (192). The apparatus includes cell modules adapted to be used in plate-and-frame or radial flow configurations.

(65) **Prior Publication Data**

US 2003/0213748 A1 Nov. 20, 2003

**Related U.S. Application Data**

(60) **Provisional application No. 60/232,548**, filed on Sep.  
14, 2000.

(51) **Int. Cl.**  
**B01D 61/48** (2006.01)

(52) **U.S. Cl.** ..... **210/243; 204/633; 204/637;**  
**204/638; 204/640; 210/266; 210/283; 210/284**

**11 Claims, 6 Drawing Sheets**

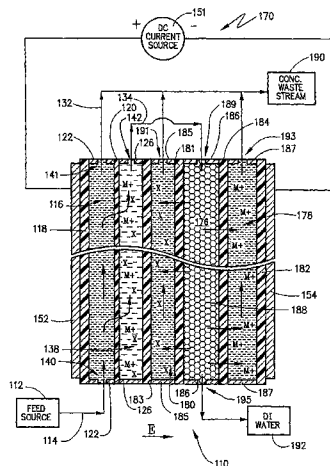

# US 6,998,044 B2

Page 2

---

## U.S. PATENT DOCUMENTS

3,905,886 A *	9/1975	Wang .....	204/532	5,061,376 A	10/1991	MacGregor	
4,032,452 A	6/1977	Davis		5,512,173 A	4/1996	Uchino et al.	
4,165,273 A	8/1979	Azarov et al.		5,951,874 A *	9/1999	Jangbarwala et al. ....	210/662
4,676,908 A *	6/1987	Ciepiela et al. ....	210/638	6,056,878 A *	5/2000	Tessier et al. ....	210/639
4,804,451 A *	2/1989	Palmer .....	204/633	6,274,018 B1 *	8/2001	Hidaka .....	204/524

\* cited by examiner



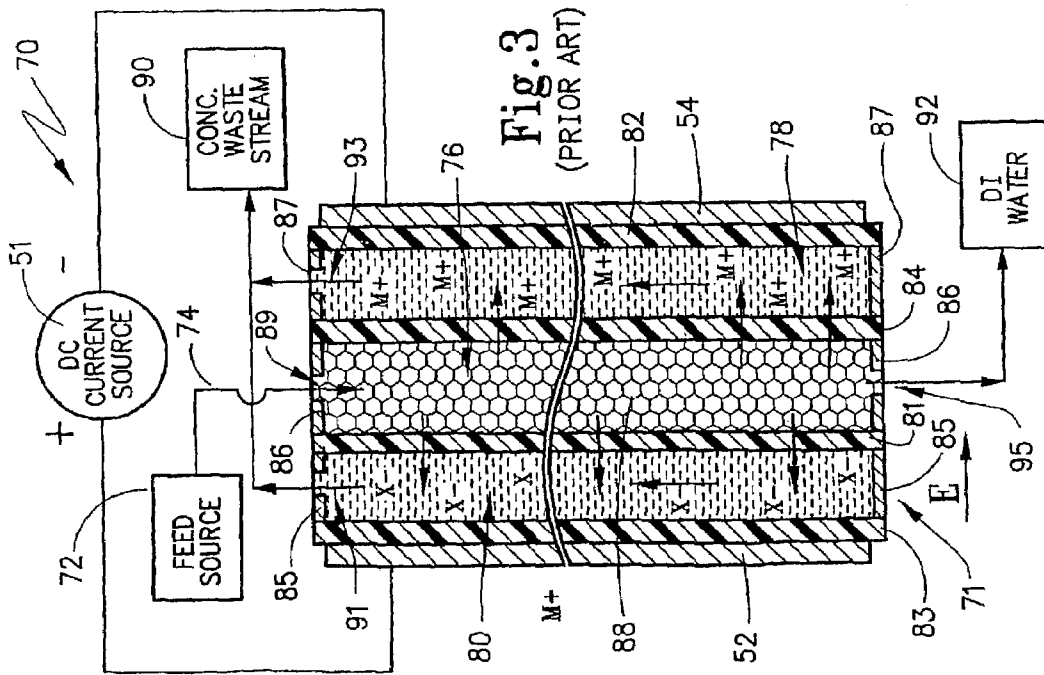
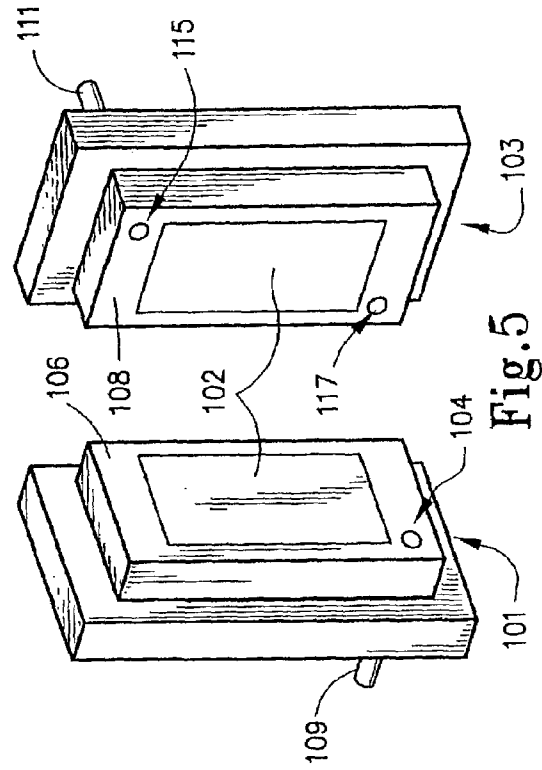
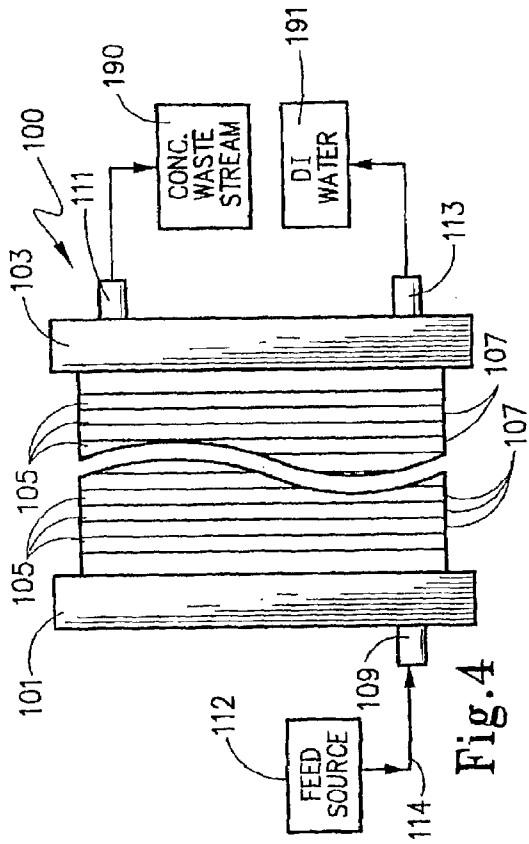

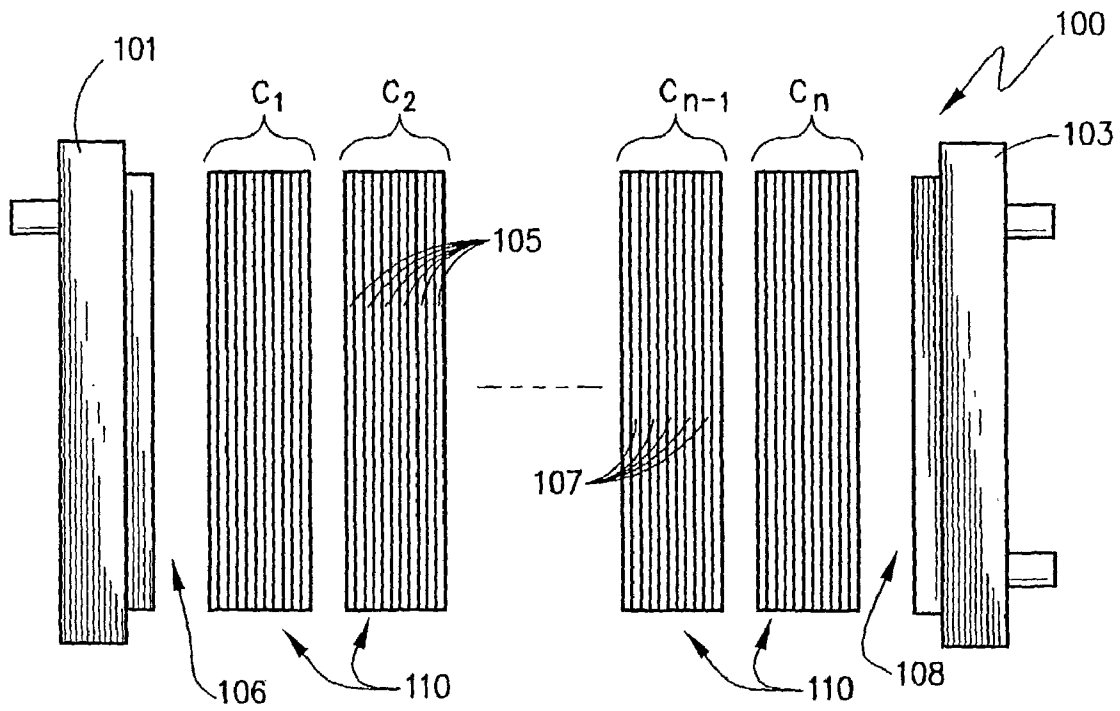

Fig. 6

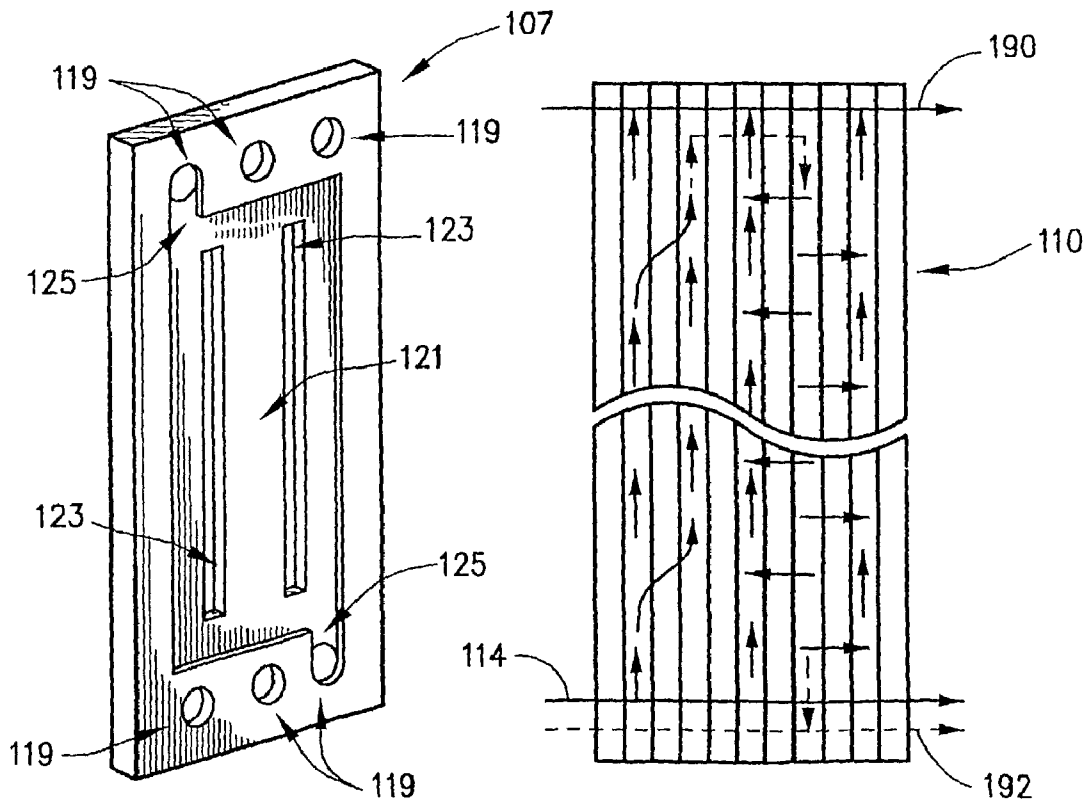

Fig. 7

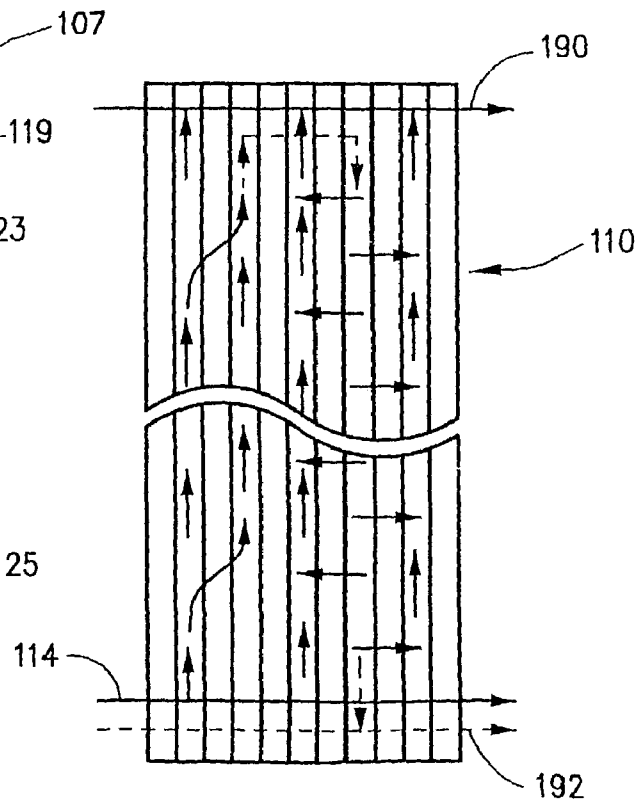

Fig. 9

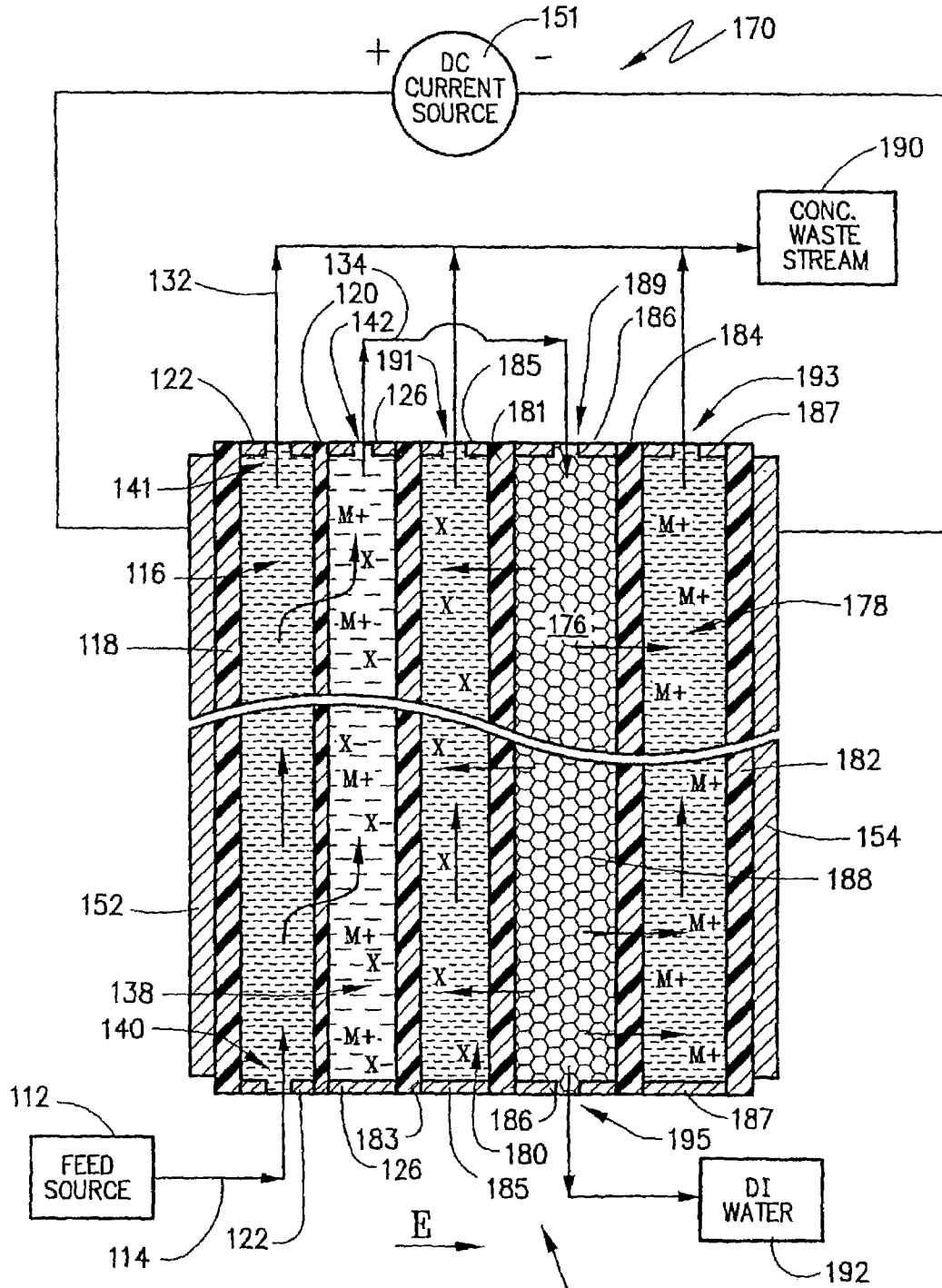

Fig. 8

110

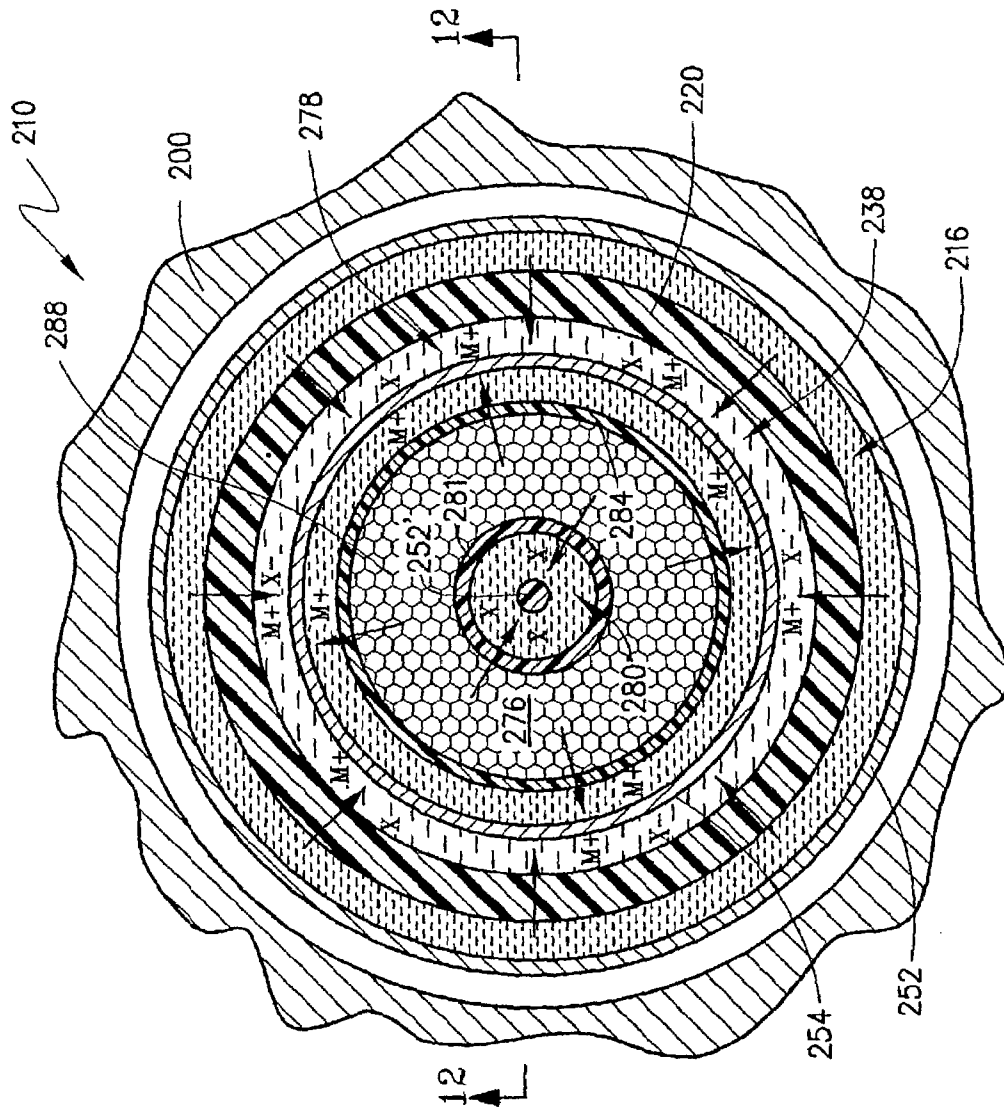

Fig. 11

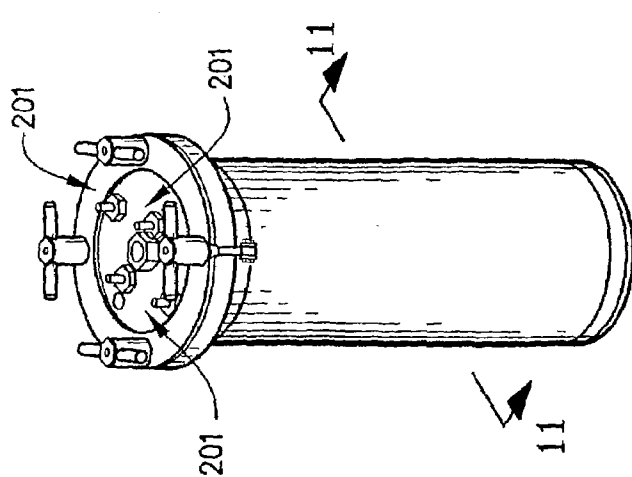

Fig. 10

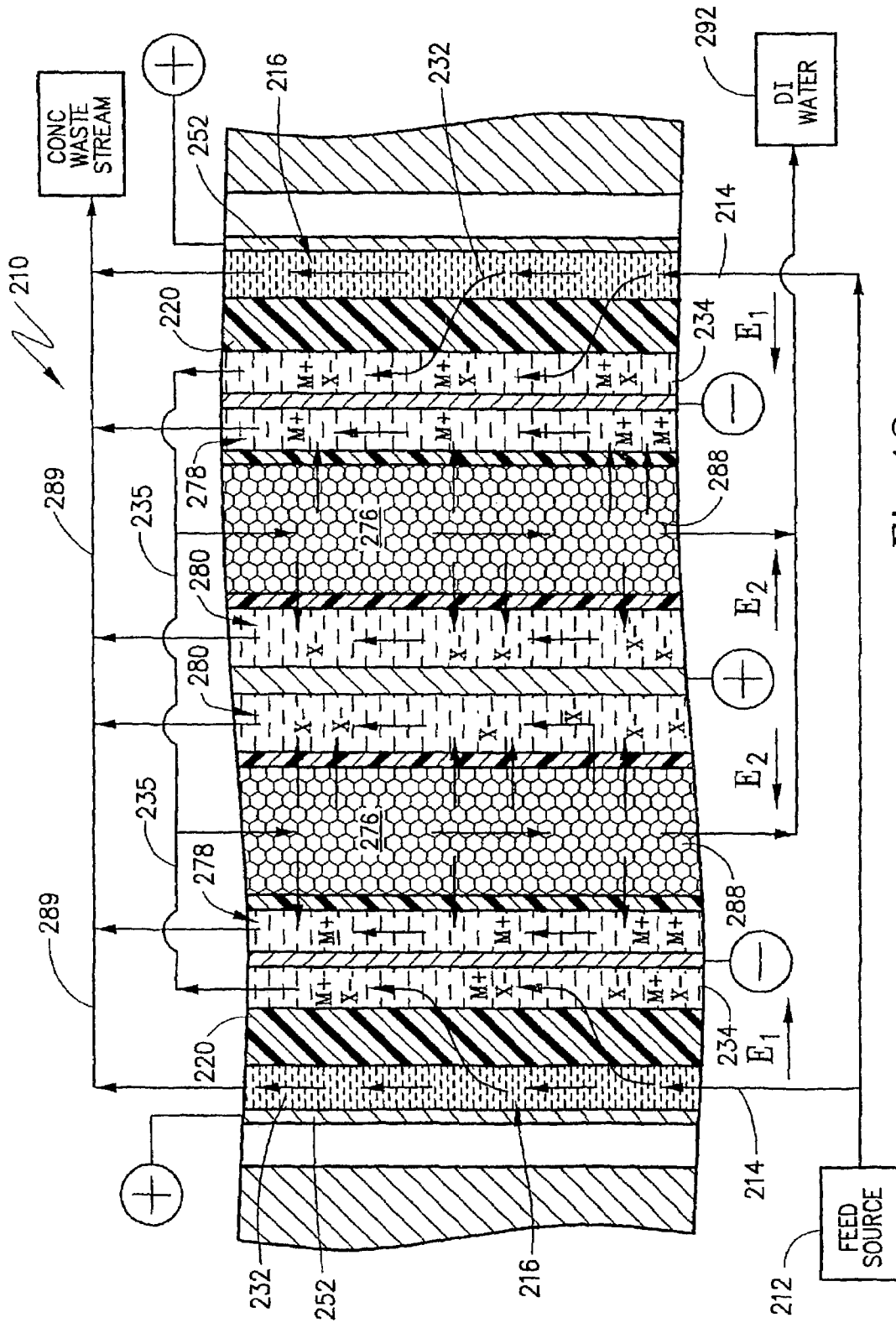

Fig.12

1

**ELECTROPHORETIC CROSS-FLOW  
FILTRATION AND  
ELECTRODEIONIZATION: METHOD FOR  
TREATING EFFLUENT WASTE AND  
APPARATUS FOR USE THEREWITH**

**CROSS-REFERENCE TO RELATED  
APPLICATIONS**

This application claims the benefit of U.S. Provisional 10  
Application No. 60/232,548, filed Sep. 14, 2000.

**FIELD OF THE INVENTION**

The present invention generally relates to the removal and 15  
collection of undesirable wastes from a waste stream, such  
as those produced as byproducts of industrial processes.  
More particularly, the present invention is directed to the  
purification of an effluent waste stream containing sus-  
pended and dissolved solids, such as metal salts. Specifi- 20  
cally, the present invention relates to a method and apparatus  
useful in removing suspended and dissolved solids from a  
solution that contains such waste products, thereby to yield  
a purified water output.

**BACKGROUND OF THE INVENTION**

Various industrial processes, such as semi-conductor fabri-  
cation, generate wastewater having high concentrations of  
suspended and dissolved solids. Such wastewater can be 30  
highly toxic, and accordingly must be purified prior to being  
sent to municipal wastewater treatment plants.

An industrial process known as Chemical Mechanical  
Planerization or polishing, (CMP) is one for which purifi- 35  
cation of the wastewater stream is of particular interest.  
CMP, which can be used in the fabrication of integrated  
circuits having copper interconnects, removes excess copper  
by a hybrid process where copper is polished off the semi-  
conductor wafer by a combination of chemical etching and 40  
physical polishing by fine aluminum oxide slurry. The  
particle size distribution of the slurry ranges generally from  
0.02 micron (200 Angstroms) to 0.10 micron (1000 Ang-  
stroms). The rinsewater wastes contain variable amounts of  
dissolved copper salts in addition to the suspended solids of  
the slurry.

Purification of the rinsewater from CMP processes pre- 45  
sents a significant challenge for waste disposal efforts. It is  
desirable to remove the suspended and dissolved solids from  
the CMP rinsewater stream. However, the solids present in  
the rinsewater can plug the flow path of conventional  
purification systems, such as filter membranes and ion- 50  
exchange resin columns, thus making such processes for  
removing wastes from the CMP rinsewater highly ineffi-  
cient. Further, conventional ion-exchange resins can be  
irreversibly damaged by oxidizers that are commonly  
present in CMP rinsewater. While activated carbon is often 55  
used to eliminate oxidizers from waste streams, the pores of  
activated carbon particles are susceptible to plugging in  
CMP rinsewater due to the particle size distribution of the  
CMP slurry waste. Additionally, the use of conventional 60  
ion-exchange resin technology requires intermittent inter-  
ruption of the purification process for regeneration of the  
resin, thereby decreasing the efficiency of the process.

Accordingly, there remains a need to provide a new and 65  
improved method of purifying wastewater streams contain-  
ing both suspended and dissolved solids, and CMP slurry in  
particular. There is a further need for methodologies for

2

purifying and recycling the wastewater from industrial  
chemical processes. Additionally, there is a need for a new  
and useful apparatus for use with the methods of the present  
invention for the treatment and processing of water contain- 5  
ing suspended and dissolved solids, such as the wastewater  
from copper CMP manufacturing processes. The present  
invention is directed to meeting these needs.

**SUMMARY OF THE INVENTION**

It is an object of the present invention to provide a new  
and useful method for removing suspended and dissolved  
solids from waste generated by industrial processes.

It is another object of the present invention to provide an  
efficient method for filtering suspended solids and removing  
dissolved salts from a wastewater stream.

It is yet another object to provide a new and useful  
apparatus operative to efficiently purify water generated by  
industrial fabrication processes.

A still further object is to provide a method and apparatus  
for purifying wastewater that does not require intermittent  
interruption of the purification process.

According to the present invention then, a method is  
provided for purifying water that contains suspended and 25  
dissolved solids. The method first comprises filtering the  
water in a cross-flow direction with a filter membrane in the  
presence of an electric field that is operative to drive  
suspended particles away from a surface of the filter mem-  
brane. The filter membrane is operative to retain a majority  
of the suspended solids thereby to form a retentate contain- 30  
ing suspended solids, and to pass at least some of the  
dissolved solids thereby to form a permeate containing  
dissolved solids. The method next comprises passing the  
permeate through a mixture of at least one cation-exchange  
resin and at least one anion-exchange resin disposed  
between a cation-selective membrane and an anion-selective  
membrane in the presence of an electric field. The electric  
field is operative to drive a majority of cations in the  
permeate through the cation-selective membrane, and to  
drive a majority of anions in the permeate through the  
anion-selective membrane, thereby to form deionized water.  
The method may further include collecting the retentate and  
the cations and anions for disposal.

The present invention also provides an apparatus for use  
in purifying water that contains suspended and dissolved  
solids. The apparatus comprises a retentate chamber sized  
and adapted to receive a selected volume of fluid, wherein  
the retentate chamber includes an inlet adapted to be placed  
in fluid communication with a source of the water that  
contains suspended and dissolved solids; a permeate cham- 45  
ber adjacent the retentate chamber and sized and adapted to  
receive a selected volume of fluid; a filter membrane inter-  
posed between the retentate chamber and the permeate  
chamber, wherein the filter membrane is operative when the  
inlet is in fluid communication with the source to retain in  
the retentate chamber a majority of the suspended solids  
thereby to form in the retentate chamber a retentate con-  
taining suspended solids, and to pass to the permeate cham-  
ber at least some of the dissolved solids thereby to form in  
the permeate chamber a permeate containing dissolved  
solids; a diluting chamber sized and adapted to receive a  
selected volume of the permeate, wherein the diluting cham-  
ber includes a mixture of at least one cation exchange resin  
and at least one anion exchange resin disposed therein; a first  
conduit interconnecting the permeate chamber and the dilut-  
ing chamber and operative to establish fluid communication  
therebetween; an outlet communicating with the diluting

chamber and operative to receive deionized water therefrom; a cation concentrating chamber adjacent the diluting chamber; a cation-selective membrane interposed between the diluting chamber and the cation-concentrating chamber, wherein the cation-selective membrane is operative to retain anions in the diluting chamber and to pass cations into the cation-concentrating chamber; an anion-concentrating chamber adjacent the diluting chamber; an anion-selective membrane interposed between the diluting chamber and the anion-concentrating chamber, wherein the anion-selective membrane is operative to retain cations in the diluting chamber and to pass anions into the anion-concentrating chamber; a second conduit communicating with at least one of the retentate chamber, cation-concentrating chamber and anion-concentrating chamber and adapted to receive the suspended and dissolved solids therefrom; and at least one cathode and anode operative to create an electric field across the retentate chamber, permeate chamber, diluting chamber, cation-concentrating chamber and anion-concentrating chamber.

The chambers may be formed by a plurality of alternating membranes and spacers, such as gasketed monofilament screen spacers. The alternating membranes and spacers may be sandwiched between an input endplate and an output endplate, where the input and output endplates each include an electrode adapted to be placed in electrical communication with an electrical current source. In particular, the diluting chamber may be defined by a spacer sandwiched between the anion-selective membrane and the cation-selective membrane, while the retentate chamber and permeate chamber may each be defined by a spacer sandwiched between the filter membrane and a cation-selective membrane, and the cation-concentrating chamber and the anion-concentrating chamber may be each defined by a spacer sandwiched between a cation-selective membrane and an anion-selective membrane.

In an alternative embodiment, the anode, cathode, filter membrane, cation-selective membrane and anion-selective membrane may be configured as concentric cylinders, where the apparatus further includes a second anode disposed along a longitudinal axis of the cylinders. The filter membrane may be disposed radially inwardly from the anode thereby to define the retentate chamber therebetween; the cathode may be disposed radially inwardly from the filter membrane thereby to define the permeate chamber therebetween; the cation-selective membrane may be disposed radially inwardly from the cathode thereby to define the cation-concentrating chamber therebetween; and the anion-selective membrane may be disposed radially between the cation-selective membrane and the second anode thereby to define the diluting chamber between the anion-selective membrane and the cation-selective membrane and to define the anion-concentrating chamber between the anion-selective membrane and the second anode.

The present invention also provides a system for use in purifying water that contains suspended and dissolved solids, as well as a cell module for use in an apparatus or system according to the present invention.

These and other objects of the present invention will become more readily appreciated and understood from a consideration of the following detailed description of the exemplary embodiments of the present invention when taken together with the accompanying drawings, in which:

#### BRIEF DESCRIPTION OF THE DRAWINGS

FIG. 1 is a diagrammatic cross-sectional view of a prior art cross-flow filtration cell;

FIG. 2 is a diagrammatic cross-sectional view of a prior art electrophoretic cross-flow filtration cell

FIG. 3 is a diagrammatic cross-sectional view of a prior art electrodeionization cell:

FIG. 4 is a side view in elevation of a new and useful electrophoretic electrodeionization apparatus according to the present invention;

FIG. 5 is a perspective view in elevation of an input endplate and an output endplate detached from the apparatus of FIG. 4;

FIG. 6 is a partially exploded side view in elevation of the apparatus according to FIG. 4;

FIG. 7 is a perspective view of an exemplary spacer for use in the apparatus of the present invention;

FIG. 8 is a diagrammatic cross-sectional view of an electrophoretic electrodeionization cell for use in the apparatus of FIG. 4;

FIG. 9 is a diagrammatic view showing the flow paths of fluid through an electrophoretic electrodeionization cell of the apparatus of FIG. 4;

FIG. 10 is a perspective view of a cylindrical canister housing a second embodiment of the present invention;

FIG. 11 is a diagrammatic top view in cross section of the radial-flow embodiment of FIG. 10; and

FIG. 12 is a diagrammatic cross-sectional side view of the embodiment of FIG. 10.

#### DETAILED DESCRIPTION OF THE EXEMPLARY EMBODIMENTS

The present invention provides a method and apparatus for purifying effluent waste from industrial processes, such as Chemical Mechanical Planerization or polishing (CMP) processes used in various industries, including semi-conductor manufacturing. The effluent waste from such industrial processes may contain high concentrations of dissolved and suspended solids. For example, effluent from CMP processes may contain approximately 500–5000 parts per million (ppm) of suspended solids and 5–250 ppm copper (II) ion. Current environmental regulations require that the effluent be reduced to less than 5 ppm suspended solids and 0.1–2 ppm copper before it may be discharged into a waste treatment system. A single semi-conductor fabrication plant may produce 200 gallons per minute of CMP effluent from copper and other CMP processes, such that the purification of the wastewater streams from such plants is a significant endeavor. Accordingly, it is important to provide an efficient and economical method for purifying effluent from such plants that is able to meet the required regulatory standards.

Toward that end, the present invention provides an apparatus incorporating electrophoretic cross-flow membrane filtration technology combined with electrodeionization technology. In particular, the apparatus includes one or more electrophoretic electrodeionization cells for removing suspended and dissolved solids from a wastewater stream passing therethrough. The present invention is especially advantageous in its ability to remove suspended solids without these solids excessively blocking or plugging the filter membranes. Additionally, the present invention does not require intermittent interruption in the purification process for regeneration procedures, as might be required with conventional ion-exchange resin processes for removing dissolved solids, for example. Further, the apparatus,

according to the present invention may be modified to accommodate the desired flow rate of effluent to be treated. In particular, a greater or lesser number of electrophoretic electrodeionization cells may be incorporated into the apparatus to accommodate a given flow rate of effluent there-through, as well as to accommodate various concentrations of solids therein.

Various technologies have been developed for purifying rinsewater waste streams. In particular, cross-flow membrane filtration and electrophoretic cross-flow membrane filtration technologies have been developed to address the problems associated with removing suspended solids from a solution. Electrodeionization technologies have been developed for removing dissolved solids, such as various metal salts, from a solution.

Turning to FIG. 1, it can be seen that a cross-flow filtration cell 10 includes an inlet chamber 16 defined on one side by a membrane 18, such as a dialyzing cellophane membrane, and on an opposite side by a filter 20, such as an 0.8  $\mu\text{m}$  porosity microfilter, an ultrafilter or other appropriate filter for a selected particulate size distribution. Outlet chamber 38 lies on the opposite side of filter 20 from inlet chamber 16. Outlet chamber 38 is defined on one side by filter 20 and on an opposite side by another membrane 24, which may be a dialyzing membrane similar to membrane 18. Alternatively, supports as known in the art may be used in place of membranes 18 and 24. The remaining sides of inlet chamber 16 and outlet chamber 38 are respectively defined by a first spacer 22 disposed between membrane 18 and filter 20 and a second spacer 26 disposed between filter 20 and membrane 24. Spacers 22 and 26 may be gasketed monofilament screen spacers as known in the art.

As shown in FIG. 1, a feed source 12 provides a solution 14 having suspended solids therein through an inlet aperture 40 in spacer 22. Solution 14 is passed into inlet chamber 16 and passes in a cross-flow direction to filter 20. This method of cross-flow filtration of solution 14 reduces filter membrane fouling by reducing build up of filter cake 28, by continuously sweeping the filter membrane surface in the direction of flow of solution 14, shown by arrow 30.

A retentate 32 and permeate 34 are thus formed. In particular, retentate 32 contains particles having a particle size greater than the pore size of filter membrane 20, and that accordingly do not pass therethrough. An appropriate filter membrane 20 may be chosen to retain suspended solids of a selected particle size distribution, as appropriate for a given application. Permeate 34 includes particles having a particle size smaller than the pore size of filter membrane 20, such as dissolved metal salts. Filter membrane 20 is preferably a non-polar filter membrane that allows both cations and anions to permeate therethrough. The flow of solution 14 in the cross-flow direction 30 to filter membrane 20 extends the life of filter membrane 20 by reducing build-up of filter cake 28, and further helps to sustain the flow of permeate 34 therethrough to outlet chamber 38 as shown by arrows 36. Retentate 32 and permeate 34 flow through outlet apertures 41 and 42 in spacers 22 and 26, respectively, for collection.

To further enhance the filtration of solutions having suspended solids therein, the technology of electrophoretic cross-flow membrane filtration was developed. As shown in FIG. 2, an anode 52 and a cathode 54 are disposed adjacent a cross-flow filtration cell 10, such as that shown in FIG. 1. Anode 52 and cathode 54 may be standard plate-type electrodes as known in the art. In an electrophoretic cross-flow membrane system 50 as shown in FIG. 2, a DC current source 51 in electrical communication with anode 52 and

cathode 54 provides a DC current thereto, thereby to generate an electric field E across the cross-flow membrane filtration cell 10. While anode 52 and cathode 54 are diagrammatically shown placed immediately adjacent membranes 18 and 24, it should be appreciated that anode 52 and cathode 54 may be disposed in varying locations within a system, such as further distances from membranes 18 and 24, provided electric field E is generated therebetween by the positioning thereof. Such varying placement may permit the stacking of a plurality of cells 10 between anode 52 and cathode 54, thereby to form an electrophoretic filtration system comprising a plurality of cells disposed in electric field E.

Inlet chamber 16 is preferably positioned such that it is disposed between anode 52 and filter membrane 20. Outlet chamber 38 is preferably disposed between cathode 54 and filter membrane 20. In electrophoretic cross-flow membrane filtration system 50, electric field E enhances the cross-flow filtration process by electrophoretically driving particles away from the surface of filter membrane 20 in the direction of arrows 56, thereby to suppress formation of a filter cake and maintain the efficiency of filter membrane 20. That is, because the suspended solids in solution 14 provided by feed source 12 generally carry a negative charge, these particles electrophoretically migrate in the direction of anode 52, away from filter membrane 20, and opposite the general direction of flow of permeate 34 through filter 20 as shown by arrows 36. Suspended particles thus remain in retentate 32, which passes through outlet 41 of spacer 22. Retentate 32 containing the suspended solids can thereafter be disposed of by various methods as known in the art.

Electrodeionization technology combines electro dialysis and ion-exchange resin deionization technologies to remove dissolved salts from aqueous streams. In particular, an electric potential forces ions present in an aqueous feed stream that is sent through a diluting chamber into adjacent concentrating chambers. The use of ion-exchange resins in the diluting chamber allows for the efficient migration of ions. That is, the ion-exchange resins act as ion conduits for the transport of cations and anions to a cation concentrating chamber and an anion concentrating chamber, respectively.

A standard electrodeionization apparatus includes alternating layers of anion-selective and cation-selective membranes spaced within a plate-and-frame module, as known in the art, thereby to form parallel diluting and concentrating chambers. Anion-selective membranes are permeable to anions but not to cations or to water. Cation-selective membranes are permeable to cations but not to anions or to water.

In particular, as shown in FIG. 3, an electrodeionization system 70 utilizes one or more electrodeionization cells 71 disposed between an anode 52 and a cathode 54. Each cell 71 has a diluting chamber 76, a cation concentrating chamber 78 and an anion concentrating chamber 80. DC current source 51 provides a DC current to the electrodes, anode 52 and cathode 54 respectively, which operate under a DC voltage potential to generate an electric field E across cell 71. The cation concentrating chamber 78 is disposed between the diluting chamber 76 and the cathode 54, and is defined on the cathode side thereof by an anion-permeable membrane 82 and on the anode side thereof by a cation permeable membrane 84. The anion concentrating chamber 80 is similarly defined on the cathode side thereof by an anion-permeable membrane 81 and on the anode side thereof by a cation-permeable membrane 83. The diluting chamber 76 is disposed between the cation concentrating chamber 78 and the anion concentrating chamber 80 and is

defined on the cathode side by cation-permeable membrane **84** and on the anode side by anion-permeable membrane **81**. The anion-permeable and cation-permeable membranes may be fixed to thin inert polymer frames for support, as known in the art. The remaining sides of each chamber are defined by spacers **85**, **86** and **87**, respectively, such as gasketed monofilament screen spacers as known in the art. In particular, spacer **85** is sandwiched between cation-permeable membrane **83** and anion-permeable membrane **81** to define anion concentrating chamber **80**. Spacer **86** is sandwiched between anion-permeable membrane **81** and cation-permeable membrane **84** to define diluting chamber **76**. Spacer **87** is sandwiched between cation-permeable membrane **84** and anion-permeable membrane **82** to define cation concentrating chamber **78**. Diluting chamber **76** is filled with a mixture of cation and anion exchange resins **88**.

It can be seen that a feed source **72** provides a solution **74** containing metal salts, such as copper salts from a CMP rinsewater stream. Solution **74** is passed through an inlet aperture **89** in spacer **86** into diluting chamber **76** where it contacts the mixture of cation and anion exchange resins **88**. The unwanted ions from the water are exchanged for either hydroxyl or hydrogen ions from the resins, and are then transported to the appropriate concentrating compartment in response to the electric field E. That is, the anion-exchange resins in mixture **88** exchange hydroxyl ions for the anions of the dissolved salts, and the cation-exchange resins in mixture **88** exchange hydrogen ions for the cations of the dissolved salts. The DC electrical potential of electrical field E drives the ions along the surfaces of the ion-exchange resins, which are generally formed in small particles such as beads, and through the membranes into the appropriate concentrating compartment. That is, cations, shown by M+, migrate toward cathode **54** through the cation-permeable membrane **84** that defines the cathode side of diluting chamber **76**. The cations are trapped by the anion-permeable membrane **82** that defines the cathode side of cation concentrating chamber **78**, thereby retaining the cations M+ in the cation concentrating chamber **78**. Anions, shown by X-, migrate toward anode **52** through the anion-permeable membrane **81** that defines the anode side of diluting chamber **76**. The anions are trapped by the cation-permeable membrane **83** that defines the anion side of anion concentrating chamber **80**, thereby retaining the anions X- in the anion concentrating chamber **80**. The concentrated anions and cations are then removed through outlet apertures **91** and **93** in spacers **85** and **87**, respectively, as a concentrate waste stream **90**. Deionized water **92**, resulting from the removal of the undesired cations and anions of the dissolved salts from feed solution **74**, is passed from diluting chamber **76** through outlet aperture **95** in spacer **86**.

EDI technology takes advantage of a phenomenon wherein, under localized areas of high potential gradients from electrical field E, water is "split" into hydrogen ions (H+) and hydroxyl ions (OH-), which results in the constant regeneration of the ion-exchange resins **88** in diluting chamber **76**. Because of this constant regeneration, it is unnecessary to interrupt the water purification process to add regenerative solutions, such as acid or base solutions, as is commonly required in traditional purification procedures utilizing ion-exchange resins.

Turning to FIG. 4, an electrophoretic electrodeionization apparatus **100** according to the present invention comprises an input endplate **101**, an output endplate **103** and a plurality of alternating membranes **105** and spacers **107** sandwiched therebetween. Endplates **101** and **103** are preferably formed of a suitable structurally rigid material such as polycarbon-

ate. Spacers **107** may be gasketed monofilament screen spacers as known in the art for use in plate-and-frame type EDI modules. Membranes **105** are various anion-selective, cation-selective and filter membranes arranged as discussed more fully hereinbelow. The input endplate **101** includes an input port **109** adapted to be placed in fluid communication with a feed source **112** operative to provide a solution **114** containing suspended and dissolved solids. The output endplate **103** includes a waste outlet port **111** and a deionized (DI) water outlet port **113**. The waste outlet port **111** is operative to receive a concentrate waste stream **190** from apparatus **100**, and the DI water outlet port **113** is operative to receive DI water **191** from apparatus **100**. Ports **111** and **113** may be sized and adapted to fluidly communicate with selected conduits, such as waste drains and water taps, for receiving the concentrate waste stream **190** and DI water **191**, respectively.

As shown in FIG. 5, input endplate **101** and output endplate **103** each include an electrode **102** adapted to be placed in electrical communication with a DC current source. Electrodes **102** are preferably platinum plate-type electrodes, which may be inset in endplates **101** and **103** so as to be flush with surfaces **106** and **108**, respectively, of endplates **101** and **103**. Input endplate **101** further includes an input aperture **104** in surface **106**, such as a bore extending through endplate **101** in fluid communication with input port **109**. Output endplate **103** includes a waste outlet aperture **115** and a DI water outlet aperture **117** in surface **108**. Waste outlet aperture **115** is in fluid communication with waste outlet port **111**, and DI water outlet aperture **117** is in fluid communication with DI water outlet port **113**. It should be appreciated that various other constructions of endplates **101** and **103** are contemplated, such as shown for example in U.S. Pat. No. 4,465,573 to O'Hare.

As shown in FIG. 6, apparatus **100** may include a plurality of cells **110**, designated C<sub>1</sub> to C<sub>n</sub>, which are sandwiched between endplates **101** and **103**. Each cell **110** includes a selected number of alternating membranes **105** and spacers **107** as more fully described below. The first cell, C<sub>1</sub>, is disposed adjacent surface **106** of input endplate **101**, and the last cell, C<sub>n</sub>, is disposed adjacent surface **108** of output endplate **103**. It should be appreciated that the number of cells **110** can be varied according to the conditions of operation of apparatus **100**. In particular, the number of cells can be adjusted according to the volume and/or flow rate of the feed solution, as well as according to the concentration of impurities therein. Specifically, it should be appreciated that the cells **110** of apparatus **100** may be fluidly aligned in parallel so that higher flow rates of the feed solution may be accommodated by adding more cells to the apparatus, and to further prevent the concentrate waste stream from becoming increasingly more concentrated with salts as it otherwise would if aligned in series.

An exemplary spacer **107** for use with the present invention is illustrated in FIG. 7. Spacers **107** are preferably generally rectangular in shape, although other geometric shapes are contemplated. Each spacer may include a plurality of apertures **119** and a cut-out channel **121** cut partly or fully through the thickness of spacer **107** and interconnecting various apertures **119**. When cut-out channel **121** is cut only partially through spacer **107**, slots **123** may further be provided through spacer **107** thereby to provide fluid communication from one side of spacer **107** to another. It should be appreciated that when a selected spacer **107** is sandwiched between two membranes **105**, such as shown in FIG. 6, cut-out channel **121** forms a chamber sized and adapted to receive a selected volume of fluid. Inlet/outlet channel

cut-outs **125** positioned between cut-out channel **121** and selected ones of apertures **119** permit fluid to be directed along a selected flow path through the selected ones of apertures **119** and through the chamber formed when spacer **107** is sandwiched between two membranes **105**. It should be appreciated that spacers **107** may include variable numbers of apertures **119** and variations in the positioning of the inlet/outlet channel cut-outs **125**, such that spacers having numerous combinations of flow paths between various apertures **119** may be formed. Additionally, the apertures **119** of adjacent spacers **107** may be aligned with one another so as to create selected flow paths between adjacent spacers.

An electrophoretic electrodeionization system **170** according to the present invention is illustrated in FIG. **8**. System **170** includes at least one electrophoretic electrodeionization cell **110**. Each cell **110** includes an inlet chamber **116**, an outlet chamber **138**, a diluting chamber **176**, a cation concentrating chamber **178** and an anion concentrating chamber **180**. One or more of cells **110** are disposed between anode **152** and cathode **154**, which are in electrical communication with DC current source **151**. DC current source **151** provides a DC current to the electrodes, anode **152** and cathode **154** respectively, which operate under a DC voltage potential to generate an electric field **E** across cell **110**. While anode **152** and cathode **154** are diagrammatically shown placed immediately adjacent membranes **118** and **182**, it should be appreciated that anode **152** and cathode **154** may be disposed in varying locations within a system, such as in endplates **101** and **103** astride a plurality of cells **110**, as apparent with reference to FIGS. **4-6**.

Inlet chamber **116** is defined on one side by a membrane **118**, which is preferably a cation-selective membrane, and on an opposite side by a filter membrane **120**, such as an 0.8  $\mu\text{m}$  porosity microfilter, an ultrafilter or other appropriate filter for a selected particulate size distribution. Filter membrane **120** is preferably a non-polar filter membrane that allows both cations and anions to permeate therethrough. Outlet chamber **138** lies on the opposite side of filter **120** from inlet chamber **116**, and is defined on one side by filter **120** and on an opposite side by cation-permeable membrane **183**. The remaining sides of inlet chamber **116** and outlet chamber **138** are respectively defined by a first spacer **122** disposed between membrane **118** and filter **120** and a second spacer **126** that is disposed between filter **120** and membrane **124**. Spacers **122** and **126** may be gasketed monofilament screen spacers as known in the art, and are preferably formed similarly to the construction of spacer **107** in FIG. **7**.

The cation concentrating chamber **178** is disposed generally between the diluting chamber **176** and the cathode **154**, and is defined on the cathode side thereof by an anion-permeable membrane **182** and on the anode side thereof by a cation-permeable membrane **184**. The anion concentrating chamber **180** is disposed generally between the diluting chamber **176** and the anode **152**, and is defined on the cathode side thereof by an anion-permeable membrane **181** and on the anode side thereof by the cation-permeable membrane **183**. The diluting chamber **176** is disposed between the cation concentrating chamber **178** and the anion concentrating chamber **180** and is defined on the cathode side by cation-permeable membrane **184** and on the anode side by anion-permeable membrane **181**. The various anion-permeable and cation-permeable membranes may be fixed to thin inert polymer frames for support, as known in the art. The remaining sides of each of chambers **180**, **176** and **178** are respectively defined by third spacer **185**, fourth spacer **186** and fifth spacer **187**, which may be gasketed monofilament screen spacers as known in the art, and which

are preferably constructed similarly to the construction of spacer **107** shown in FIG. **7**. In particular, spacer **185** is sandwiched between cation-permeable membrane **183** and anion-permeable membrane **181** to define anion concentrating chamber **180**. Spacer **186** is sandwiched between anion-permeable membrane **181** and cation-permeable membrane **184** to define diluting chamber **176**. Spacer **187** is sandwiched between cation-permeable membrane **184** and anion-permeable membrane **182** to define cation concentrating chamber **178**. Diluting chamber **176** is filled with a mixture of cation and anion exchange resins **188**.

In operation, feed source **112** provides solution **114** containing suspended and dissolved solids, such as the effluent from CMP processes. Solution **114** passes through an inlet aperture **140** in spacer **122**, and into inlet chamber **116** where it passes in a cross-flow direction to filter **120**. Electric field **E** enhances the cross-flow filtration process by electrophoretically driving the generally negatively charged suspended solids particles away from the surface of the filter membrane **120** and in the direction of anode **152**, thereby to suppress formation of a filter cake and maintain the efficiency of filter membrane **120**. A retentate **132** is thus formed which contains particles that do not pass through filter **120**, such as the suspended solids particles which electrophoretically migrate away from the surface of filter membrane **120** in the presence of electric field **E**. Retentate **132** flows through outlet aperture **141** in spacer **122** for collection as the concentrate waste stream **190**.

Additionally, permeate **134** thus formed includes particles having a particle size smaller than the pore size of filter membrane **120**, such as dissolved metal salts having cations and anions shown as  $\text{M}^+$  and  $\text{X}^-$ , respectively, in outlet chamber **138**. Permeate **134** is passed through outlet aperture **142** in spacer **126** and through inlet aperture **189** in spacer **186** into diluting chamber **176** where it contacts the mixture of cation and anion exchange resins **188**. The unwanted cations and anions from permeate **134**, shown as  $\text{M}^+$  and  $\text{X}^-$  respectively, are exchanged for either hydroxyl or hydrogen ions from the resins. The cations and anions then migrate to the appropriate concentrating compartment in response to the electric field **E**. In particular, the anion-exchange resins in mixture **188** exchange hydroxyl ions for the anions of the dissolved salts, and the cation-exchange resins in mixture **188** exchange hydrogen ions for the cations of the dissolved salts. The DC electrical potential of electric field **E** drives the ions along the surfaces of the ion-exchange resins, which are generally formed in small particles such as beads, and through the membranes into the appropriate concentrating compartment. That is, cations, shown by  $\text{M}^+$ , migrate toward cathode **154** through the cation-permeable membrane **184** that defines the cathode side of diluting chamber **176**. The cations are trapped by the anion-permeable membrane **182** that defines the cathode side of cation concentrating chamber **178**, thereby retaining the cations  $\text{M}^+$  in the cation concentrating chamber **178**. Anions, shown by  $\text{X}^-$ , migrate toward anode **152** through anion-permeable membrane **181** that defines the anode side of diluting chamber **176**. The anions are trapped by the cation-permeable membrane **183** that defines the anion side of anion concentrating chamber **180**, thereby to retain the anions  $\text{X}^-$  in the anion concentrating chamber **180**. The concentrated anions and cations are then removed through outlet apertures **191** and **193** in spacers **185** and **187** respectively, and added to concentrate waste stream **190**. Deionized water **192**, resulting from the removal of the undesired

11

cations and anions of the dissolved salts from permeate **134**, is passed from diluting chamber **176** through outlet aperture **195** in spacer **186**.

Water is split by the influence of electric field  $E$  into hydrogen and hydroxyl ions, which regenerate the mixture of ion-exchange resins **188** in diluting chamber **176**, such that it is unnecessary to interrupt the water purification process to add chemicals for regeneration of the ion-exchange resins.

FIG. **9** shows an exemplary diagram of a flow path of fluid through a cell **110** according to the present invention. It should be particularly noted that feed solution **114**, concentrate waste stream **190** and DI water **192** can flow entirely through cell **110** such that multiple cells can be aligned in parallel to receive feed solution **114** and produce the concentrate waste solution **190** and DI water **192** therefrom. This feature is particularly of use in adapting the present invention to variations in volume and flow rate of the feed solution, and the concentration of impurities, such as suspended and dissolved solids, therein.

As shown with reference to FIGS. **10–12**, a second embodiment of the present invention comprises a radial-flow configuration of an electrophoretic electrodeionization apparatus according to the present invention. As shown in FIG. **10**, this embodiment may be housed in a cylindrical canister **200**, such as known in the art for use with radial flow electrowinning cells and the like. Various ports **201**, such as inlet and outlet ports, are provided in canister housing **200** for fluid communication with selected interior portions of the apparatus.

As shown in FIG. **11**, the components of the electrophoretic electrodeionization apparatus **210** are arranged as concentric cylinders within canister housing **200**. It should be noted that the wall of canister housing **200** may be of a selected thickness, as desired, and as such has been shown in partially broken-away form. The components of apparatus **210** are preferably disposed centrally within canister **200** and may be spaced apart from the inner diameter thereof as shown. It should be appreciated that the components of the electrophoretic electrodeionization apparatus **210** are generally similar to those of the plate-and-frame configuration discussed above. In particular, an outer cylindrical anode **252** and an inner cylindrical cathode **254** are provided, which are in electrical communication with an electrical current source as described above to create an electrical field. A second anode **252'** is provided as a central column aligned along a longitudinal axis of canister **200**, and cathode **254** together with anode **252'** provide a further electrical field, as discussed below.

A filter membrane **220** is provided between anode **252** and cathode **254** which thereby defines inlet chamber **216** and outlet chamber **238** as shown. Water to be purified is provided to inlet chamber **216** through one or more inlet ports of canister **200** as discussed above with reference to FIG. **10**. Anion-permeable membrane **281** and cation-permeable membrane **284** together define diluting chamber **276**, which is filled with the mixture of cation and anion exchange resins **288**, as discussed above. Cation-concentrating chamber **278** is thus formed between cathode **254** and cation-permeable membrane **284**, and anion-concentrating chamber **280** is formed between anode **252'** and anion-permeable membrane **281**. Various outlet ports as discussed above with reference to FIG. **10** are in fluid communication with inlet chamber **216**, anion-concentrating chamber **280** and cation-concentrating chamber **278** to collect suspended and dissolved solids, and one or more other outlet ports are

12

in fluid communication with diluting chamber **276** to recover purified water therefrom.

As shown in FIGS. **11** and **12**, radial apparatus **210** operates similarly to the plate-and-frame apparatus discussed above. Feed source **212** provides solution **214**, containing suspended and dissolved solids, to the inlet chamber **216** where it passes in a cross-flow direction to filter **220**. The outer electric field  $E_1$  enhances the cross-flow filtration process by electrophoretically driving the suspended solids away from the surface of the filter membrane **220** and in the direction of anode **252**, thereby to suppress formation of a filter cake and maintain the efficiency of filter membrane **220**. Retentate **232** and permeate **234** are thus formed as described above. Permeate **234** is then passed through a conduit **235** into diluting chamber **276**. In response to inner electric field  $E_2$ , cations  $M^+$  and anions  $X^-$  from permeate **234** migrate through ion-exchange resins **288** to the cation-concentrating chamber **278** and anion-concentrating chamber **280**, respectively. Concentrate waste stream conduit **289** receives suspended solids from inlet chamber **216** and receives cations and anions from chambers **278** and **280**, respectively. Deionized water **292** is recovered from diluting chamber **276**.

From the foregoing, it should be apparent that the present invention contemplates electrophoretic electrodeionization cells and apparatus which may be used in standard EDI type plate-and-frame module configurations or in radial-flow configurations or other configurations as apparent to the ordinarily skilled person. The present invention also contemplates a system for purifying water utilizing electrophoretic electrodeionization cells and/or apparatus according to the present invention, and a method of purifying water comprising the steps of performing electrophoretic cross-flow membrane filtration on a solution thereby to produce a permeate and a retentate and thereafter performing electrodeionization on the permeate thereby to produce purified water. It should further be appreciated that the present invention contemplates variations to the materials and structures used in forming the electrophoretic electrodeionization cells and apparatus according to the present invention. In particular, variations in the types of membranes and ion-exchange resins are contemplated, as well as in the particular materials and structures of the spacers, endplates, electrodes, ports and other components disclosed herein.

Accordingly, the present invention has been described with some degree of particularity directed to the exemplary embodiments of the present invention. It should be appreciated, though, that the present invention is defined by the following claims construed in light of the prior art so that modifications or changes may be made to the exemplary embodiments of the present invention without departing from the inventive concepts contained herein.

I claim:

**1.** An apparatus for use in purifying water that contains suspended and dissolved solids, comprising:

- (a) a retentate chamber sized and adapted to receive a selected volume of fluid,
  - (i) said retentate chamber including an inlet adapted to be placed in fluid communication with a source of the water that contains suspended and dissolved solids;
- (b) a permeate chamber adjacent the retentate chamber and sized and adapted to receive a selected volume of fluid;
- (c) a filter membrane interposed between the retentate chamber and the permeate chamber,

- (i) said filter membrane operative when said inlet is in fluid communication with the source
- (A) to retain in the retentate chamber a majority of the suspended solids thereby to form in the retentate chamber a retentate containing suspended solids, and
- (B) to pass to the permeate chamber at least some of the dissolved solids thereby to form in the permeate chamber a permeate containing dissolved solids;
- (d) a diluting chamber sized and adapted to receive a selected volume of said permeate,
  - (i) said diluting chamber including a mixture of at least one cation exchange resin and at least one anion exchange resin disposed therein;
- (e) a first conduit interconnecting said permeate chamber and said diluting chamber and operative to establish fluid communication therebetween;
- (f) an outlet communicating with the diluting chamber and operative to receive deionized water therefrom;
- (g) a cation concentrating chamber adjacent the diluting chamber;
- (h) a cation-selective membrane interposed between the diluting chamber and the cation-concentrating chamber,
  - (A) said cation-selective membrane operative to retain anions in the diluting chamber and to pass cations into the cation-concentrating chamber;
- (i) an anion-concentrating chamber adjacent the diluting chamber;
- (j) an anion-selective membrane interposed between the diluting chamber and the anion-concentrating chamber,
  - (A) said anion-selective membrane operative to retain cations in the diluting chamber and to pass anions into the anion-concentrating chamber;
- (k) a second conduit communicating with at least one of the retentate chamber, cation-concentrating chamber and anion-concentrating chamber and adapted to receive the suspended and dissolved solids therefrom;
- (l) at least one cathode and anode operative to create an electric field across said retentate chamber, permeate chamber, diluting chamber, cation-concentrating chamber and anion-concentrating chamber; and
- (m) wherein said chamber are formed by a plurality of alternating membranes and spacers.

- 2. An apparatus according to claim 1 wherein said spacers are gasketed monofilament screen spacers.
- 3. An apparatus according to claim 1 wherein said alternating membranes and spacers are sandwiched between an input endplate and an output endplate, where said input and output endplates each include an electrode adapted to be placed in electrical communication with an electrical current source.
- 4. An apparatus according to claim 1 wherein said diluting chamber is defined by a spacer sandwiched between said anion-selective membrane and said cation-selective membrane.
- 5. An apparatus according to claim 1 wherein the retentate chamber and permeate chamber are each defined by a spacer sandwiched between the filter membrane and a cation-selective membrane.
- 6. An apparatus according to claim 1 wherein the cation-concentrating chamber and the anion-concentrating chamber are each defined by a spacer sandwiched between a cation-selective membrane and an anion-selective membrane.
- 7. An apparatus according to claim 1 wherein said anode, cathode, filter membrane, cation-selective membrane and anion-selective membrane are configured as concentric cylinders, and including a second anode disposed along a longitudinal axis of said cylinders.
- 8. An apparatus according to claim 7 wherein said filter membrane is disposed radially inwardly from said anode thereby to define said retentate chamber therebetween.
- 9. An apparatus according to claim 8 wherein said cathode is disposed radially inwardly from said filter membrane thereby to define said permeate chamber therebetween.
- 10. An apparatus according to claim 9 wherein said cation-selective membrane is disposed radially inwardly from said cathode thereby to define said cation-concentrating chamber therebetween.
- 11. An apparatus according to claim 10 wherein said anion-selective membrane is disposed radially between said cation-selective membrane and said second anode thereby to define said diluting chamber between said anion-selective membrane and said cation-selective membrane and to define said anion-concentrating chamber between said anion-selective membrane and said second anode.

\* \* \* \* \*