

A. H. PERKINS.

Treating Coal Tar to Manufacture Roofing Cement.

No. 36,632.

Patented Oct. 7, 1862.

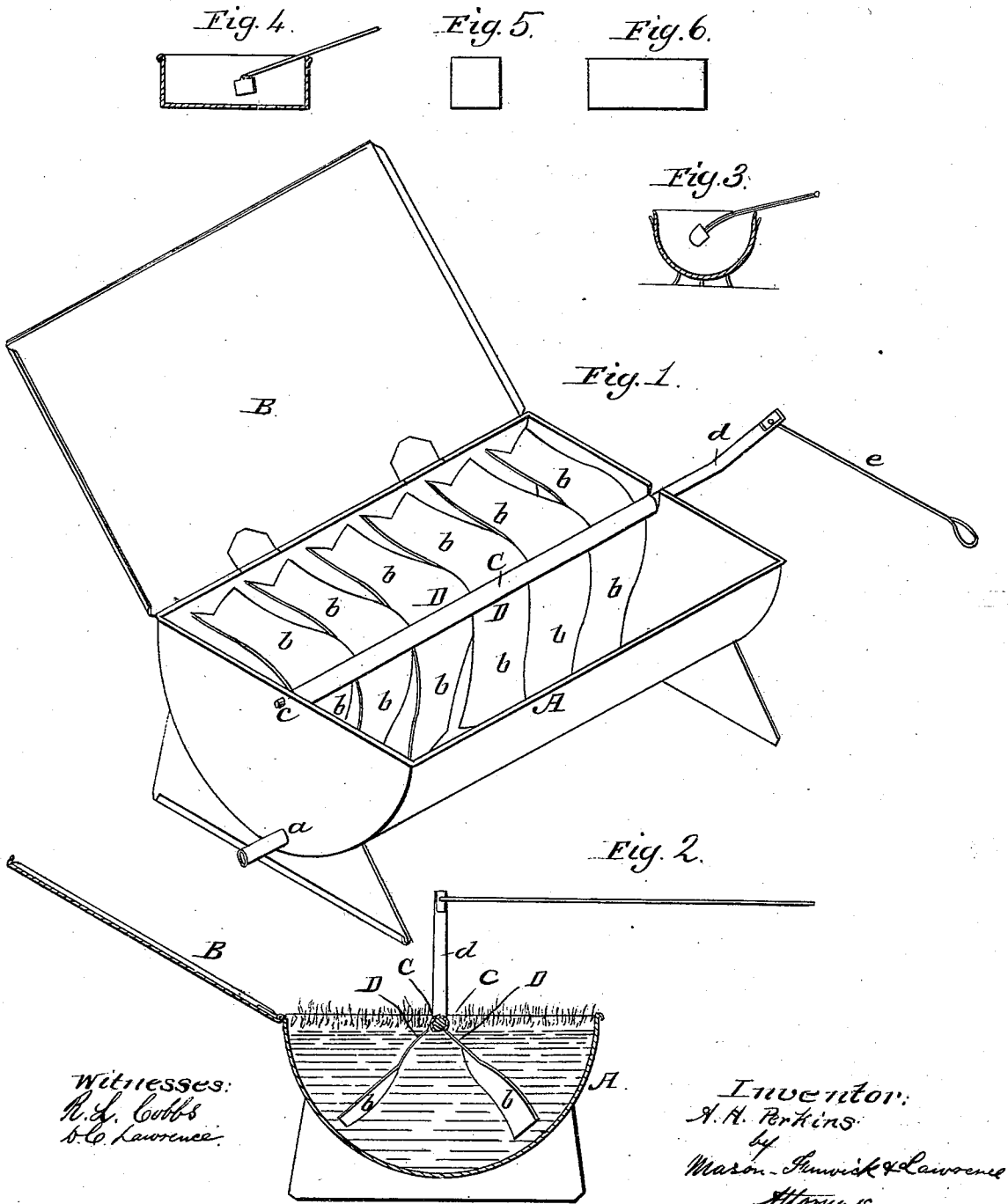

Witnesses:
H. J. Cobbs
D. C. Lawrence.

Inventor:
A. H. Perkins
by
Marion Sumwick & Lawrence
Attorneys.

UNITED STATES PATENT OFFICE.

A. H. PERKINS, OF JANESVILLE, WISCONSIN, ASSIGNOR TO HIMSELF AND JOHN M. MAY, OF SAME PLACE.

IMPROVED PROCESS OF TREATING COAL-TAR TO MANUFACTURE ROOFING-CEMENT.

Specification forming part of Letters Patent No. 36,632, dated October 7, 1862.

To all whom it may concern:

Be it known that I, A. H. PERKINS, of Janesville, county of Rock, State of Wisconsin, have invented a new and Improved Process of Treating Coal-Tar to Form a Cement for Roofing, Paving, and Coating Purposes; and I do hereby declare that the following is a full and accurate description of the same.

Coal-tar in order to be converted into cement requires to be cooked or distilled until the proper consistency is attained. To perform this operation by the old process, expensive boilers and worms were required, reaching in cost several hundred dollars. It also required a fire of such intensity under the boilers that hard coal only could be used, and beside this, many days of time were consumed in operating upon a given quantity of coal-tar.

My new process consists in igniting the bulk of coal-tar itself about its surface, and at the same time subjecting it to an agitation, thus feeding the flame and consuming and evaporating the portions necessary to be disposed of before the proper consistency can be attained.

By my process the use of hard coal or other fuel under the vessel is unnecessary, and a simple plain vessel or boiler may be used, and still the oily part of the tar and the water therein be consumed or evaporated, or so much thereof as to reduce the tar to a cement of the proper consistency for roofing buildings, &c., paving streets, when wooden blocks and timbers are used, for coating wood-surfaces, cloth-felting iron, tin, and metals of other kinds, and for analogous purposes.

In the drawings I have shown several styles of apparatus for aiding in performing the process; but I do not restrict myself to any particular form of vessel, nor to any particular style of agitator, nor to any particular mode of operating the agitator.

A, Figures 1 and 2, represents an oblong vessel with a concave or cylindric configuration in its cross-section. This vessel has an adjustable top, B, and is provided with a discharge-orifice, *a*, near its bottom at one end.

C is a longitudinal shaft with two wings, D D, which are divided up into a series of narrow blades, *b b*, bent in such manner, as shown in the drawings, as to divide and lift up the bulk of coal-tar in their movement through

it, and then allow it to flow back to its original position in the lower part of the vessel. The wings are set at a right angle, or nearly so, to one another, so that when one is horizontal with the surface of the bulk of tar the other will be vertical, or nearly so, in the same. Thus the agitation is kept up continually while the shaft is kept in motion. This agitator has its shaft C hung in bearings *c c* of the ends of the vessel, and on one end of the shaft a crank-arm, *d*, is formed, so that a rod, *e*, may be attached to it and used for rocking or vibrating the agitator in the bulk of tar.

With this apparatus the coal-tar is treated as follows: The tar is poured into the vessel and set on fire on its surface, and then stirred by the agitator sufficiently to bring all the material suitably in contact with the flame for the purpose of feeding the flame and consuming or evaporating enough of the oil and water and other articles mixed with the coal-tar, so that the residue will be of a suitable consistency for adaptation to the kind of work or purposes required. For instance, for a steep roof, very hard; flat roof, quite soft; for coating wood, or iron, or cloth and felting, medium, or as deemed desirable and practicable. When it is brought to the proper consistency, the fire is extinguished by closing the top down upon the vessel. If the lid or top should be of wood, its under surface should be thoroughly saturated or wetted with water when brought down over the flame to extinguish it, in order to obviate scorching or burning of it. The substances may be run off out of the vessel by the orifice *a*, or removed in any other manner deemed best.

In Fig. 3 I have shown a common kettle and an agitator in form of a shovel with curved handle, and in Fig. 4 a circular flaring vessel and an agitator in form of a hoe are shown. With both of these the process is performed by igniting the tar on the surface and agitating the bulk of tar below the flame, so as to bring fresh portions up to the flame continuously until the process is completed.

The vessel may be rectangular, cylindric, spheric, conic, or of any shape desired.

In Figs. 5 and 6 square and oblong vessels are shown.

Some of the advantages of my invention may be summed up as follows:

First. It saves the heavy expenses of boil-

ers, &c., used in distilling, and by which the business is retained in the hands of a few capitalists.

Second. It saves all fuel other than that in the coal-tar, and that fuel being the parts that necessarily must be thrown off or got rid of before the tar can be converted into a cement of the proper consistency.

Third. It saves time. A few hours only are needed instead of days, as with the old method.

Fourth. A greater bulk of cement is made from a given amount of material, and the product is more durable from the fact of its vulcanization by flame directly in contact with it.

Fifth. It can be made at any place, and therefore may be made hard or soft to adapt it to the inclination or flatness of the roof.

Sixth. It saves transportation from the few places where it is now made by the old process, as by the new process it can be made wherever the work of roofing, &c., is to be done, or at the numerous gas-works in the country.

I am aware that surface-burning of coal-tar

in the manufacture of lamp-black is commonly practiced. I also am aware that in the manufacture of lamp-black by burning coal-tar on the surface attempts have been made to render the residue of the coal-tar useful for cement purposes; but as the tar is not subjected to an agitation in either process, and is allowed to burn sufficiently in a still state to produce lamp-black, neither of these processes are the same as mine.

What I claim as my invention, and desire to secure by Letters Patent, is—

The new process herein described, of treating coal-tar to form a cement material, for the purposes set forth.

Witness my hand in the matter of my application for a patent for an improved process of treating coal-tar to form cement for roofs, pavements, &c., this 17th day of June, A. D. 1862.

A. H. PERKINS.

Witnesses:

C. E. HARWOOD,
JOHN THOMSON.