



US00D749174S

(12) **United States Design Patent**
O Connell

(10) **Patent No.:** **US D749,174 S**

(45) **Date of Patent:** **** Feb. 9, 2016**

(54) **SCOOTER**

(71) Applicant: **YVOLVE SPORTS LTD.**, Dublin (IE)

(72) Inventor: **Thomas O Connell**, Castleblayney (IE)

(**) Term: **14 Years**

(21) Appl. No.: **29/508,233**

(22) Filed: **Nov. 4, 2014**

(51) **LOC (10) Cl.** **21-01**

(52) **U.S. Cl.**

USPC **D21/423**

(58) **Field of Classification Search**

USPC D21/419, 421, 423, 426-428, 435,
D21/668-671, 760, 765, 771; D12/1, 8,
D12/108, 111, 112, 113

CPC B62K 3/002; B62K 9/00; B62K 9/02;
B62K 13/00; B62K 13/04; B62K 2202/00

See application file for complete search history.

(56) **References Cited**

U.S. PATENT DOCUMENTS

D191,176 S *	8/1961	Pressnerl	D21/424
D221,568 S *	8/1971	Krause	D21/435
3,751,062 A	8/1973	White	
3,870,324 A	3/1975	Balstad	
D410,058 S *	5/1999	Friend	D21/771
6,286,843 B1	9/2001	Lin	
6,315,304 B1	11/2001	Kirkland et al.	
6,382,646 B1	5/2002	Shaw	

D497,958 S *	11/2004	Campbell	D21/426
D571,863 S *	6/2008	On	D21/424
D579,502 S *	10/2008	Hourdeaux	D21/426
D631,102 S *	1/2011	Jessie, Jr.	D21/424
8,517,403 B2 *	8/2013	Jessie, Jr.	280/87.041
2002/0096846 A1	7/2002	Chen	
2005/0093262 A1	5/2005	Chang	
2007/0164530 A1	7/2007	Horn	
2011/0198819 A1 *	8/2011	Jessie, Jr.	280/7.15
2012/0181773 A1 *	7/2012	Ouboter	280/263
2014/0042717 A1 *	2/2014	Chan	280/5.509

OTHER PUBLICATIONS

EP 12192984, Extended European Search Report, Dec. 5, 2014.

* cited by examiner

Primary Examiner — Cynthia M Chin

(74) *Attorney, Agent, or Firm* — Millman IP Inc.

(57) **CLAIM**

The ornamental design for a scooter, as shown and described.

DESCRIPTION

FIG. 1 is a perspective view from above and to one side of the new design for a scooter;

FIG. 2 is a top plan view thereof;

FIG. 3 is a bottom plan view thereof;

FIG. 4 is a left side elevation view thereof;

FIG. 5 is a right side elevation view thereof;

FIG. 6 is a rear side elevation view thereof; and,

FIG. 7 is a front side elevation view thereof.

The portions of the scooter shown in broken lines are to show the environment only and form no part of the claimed design.

1 Claim, 6 Drawing Sheets

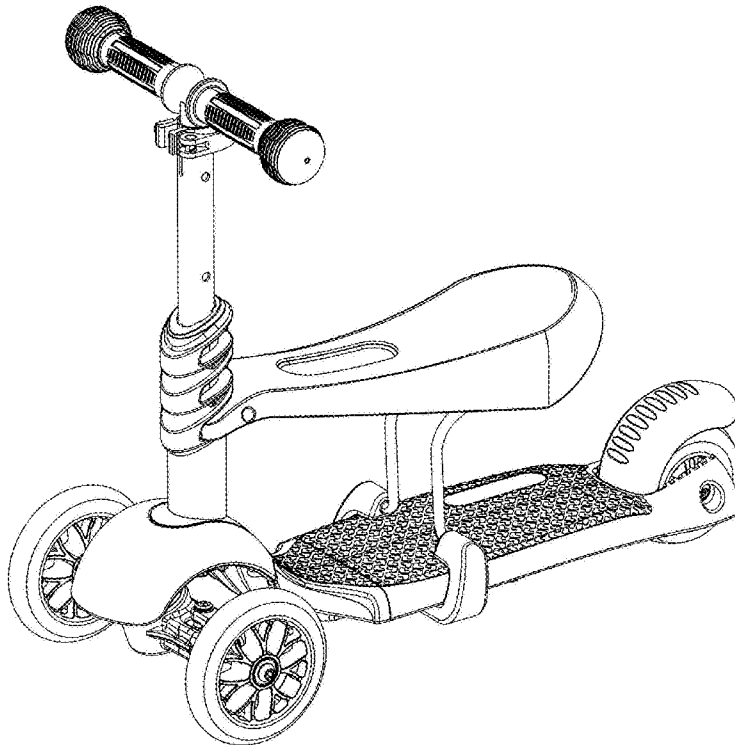

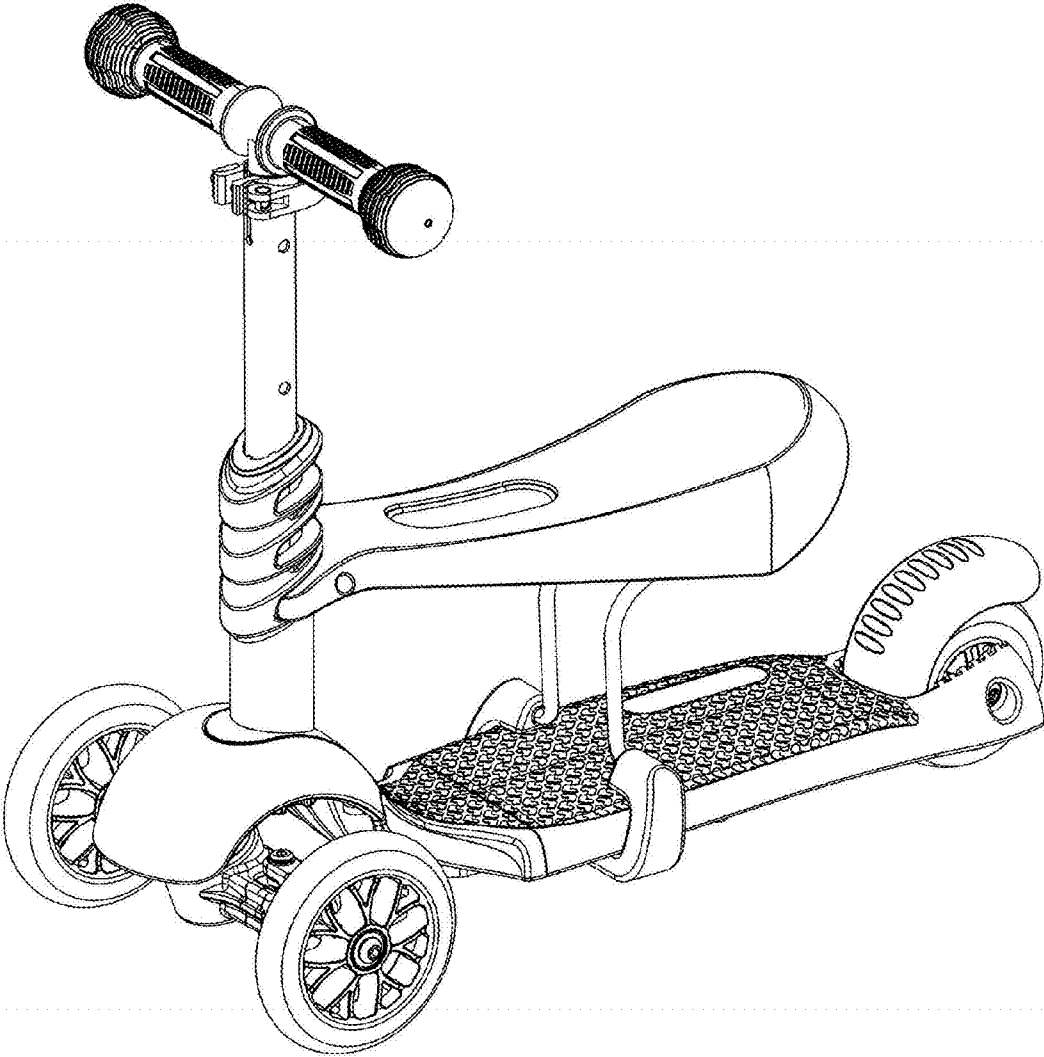

FIG. 1

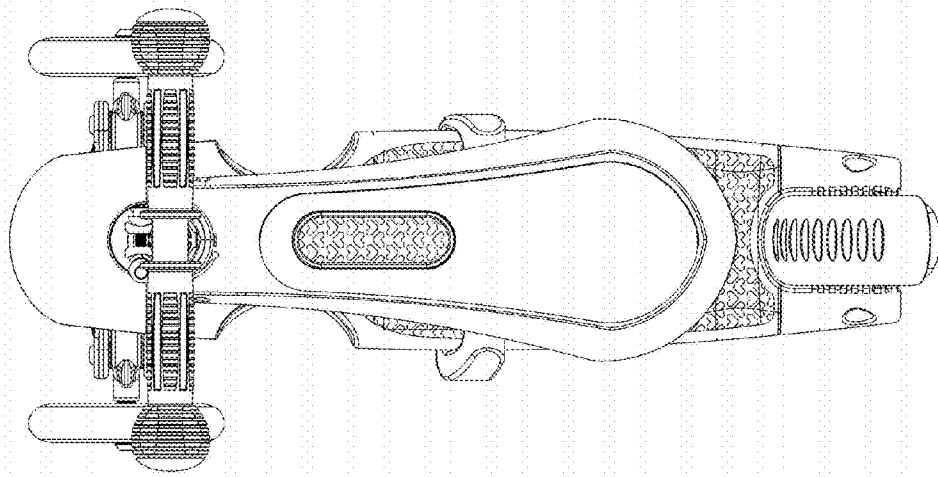

FIG. 2

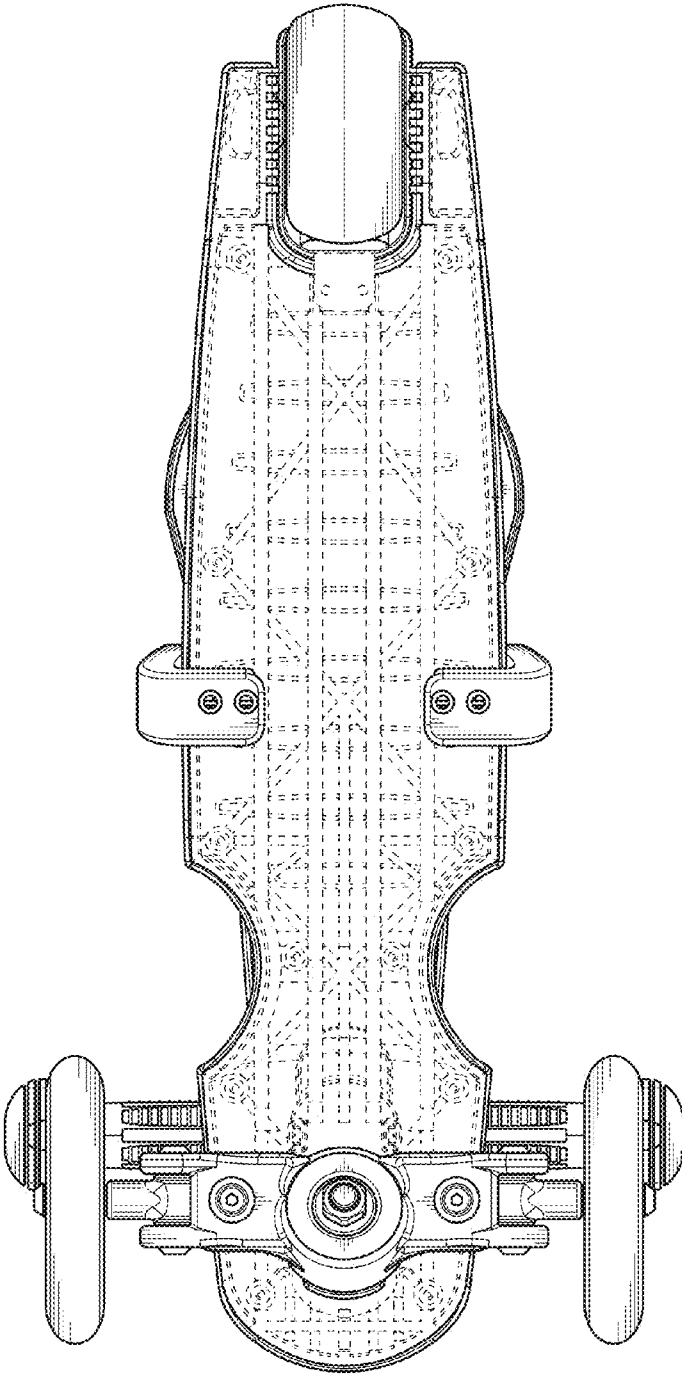

FIG. 3

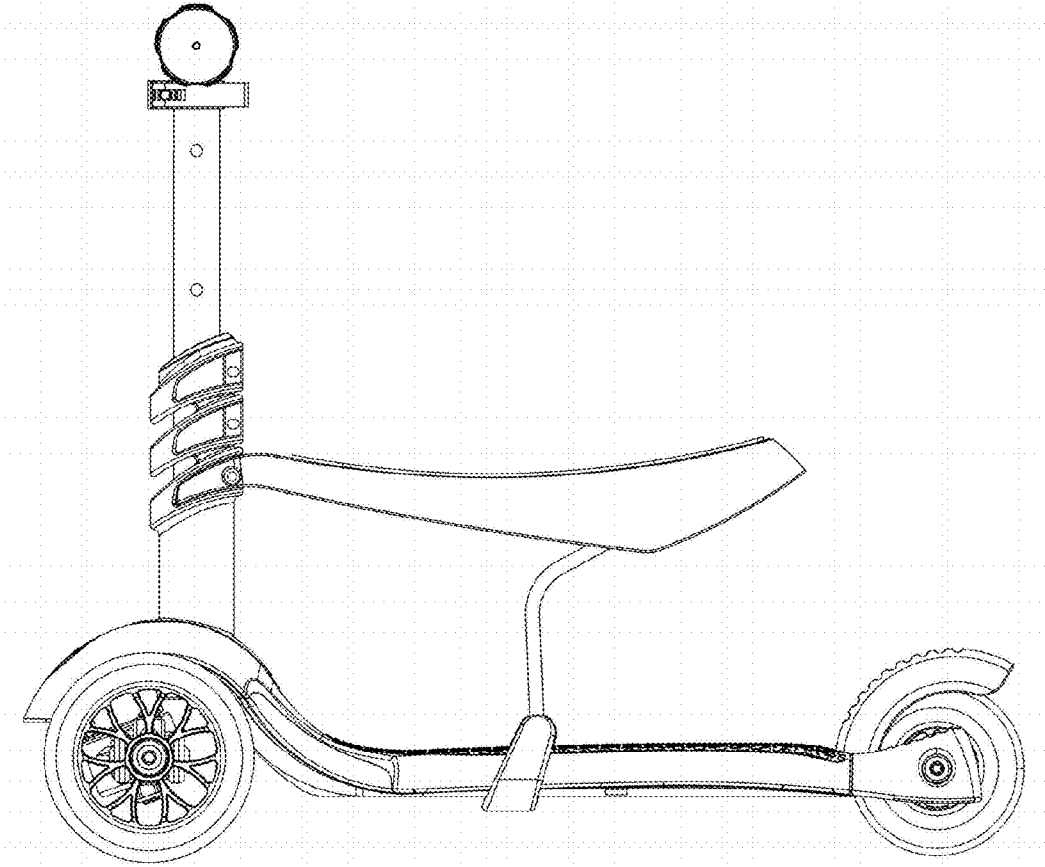

FIG. 4

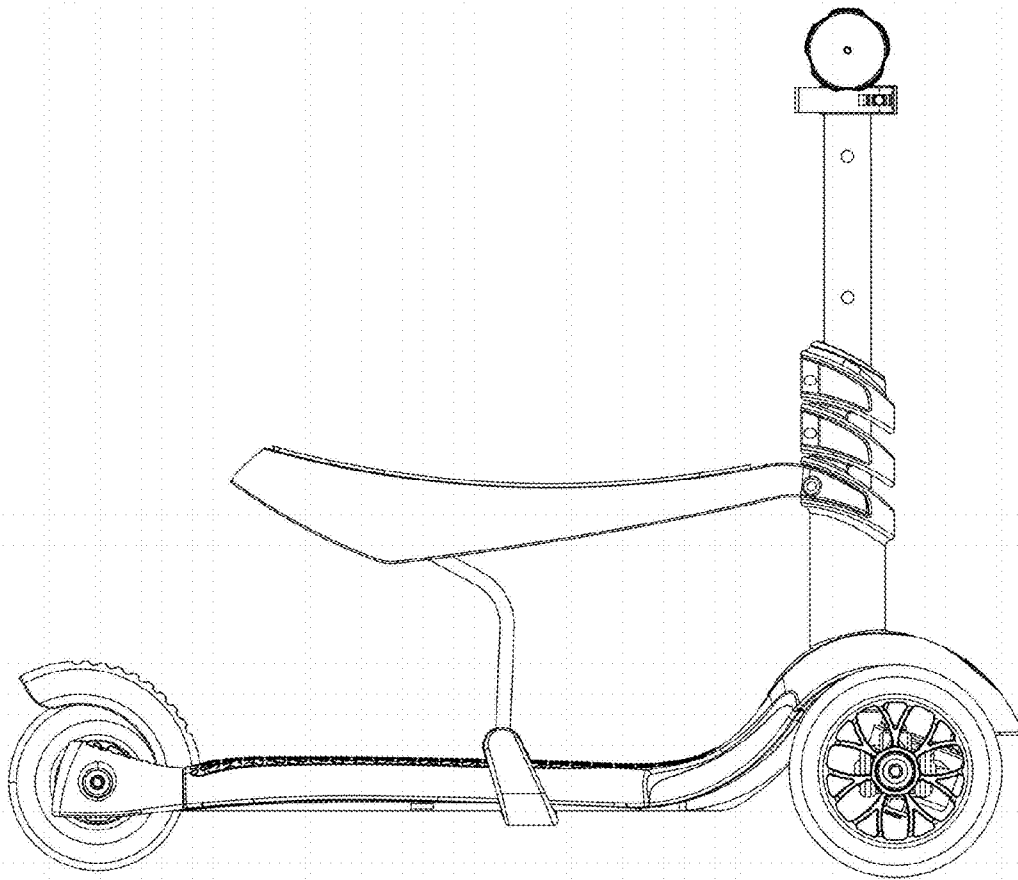

FIG. 5

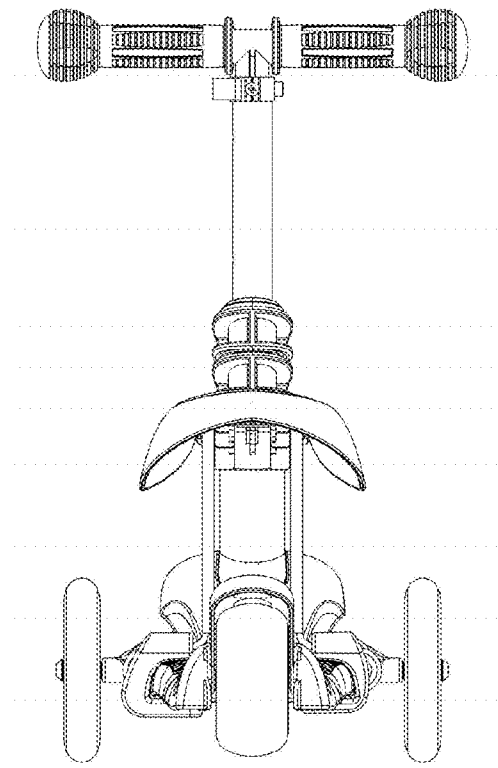

FIG. 6

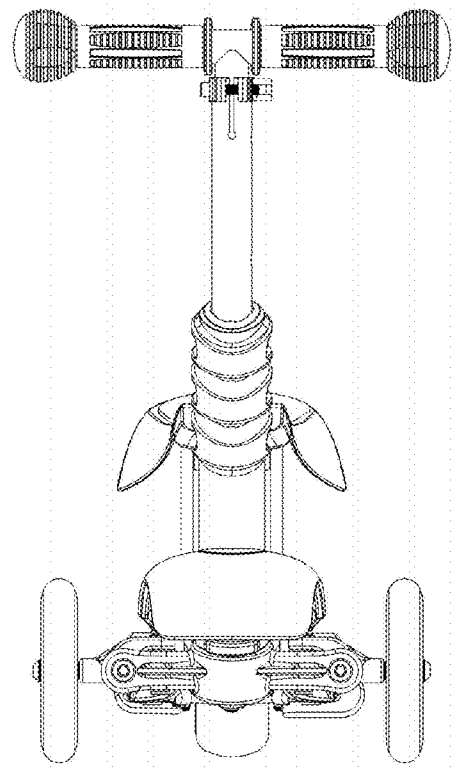

FIG. 7