

Nov. 17, 1953

H. TER MEER
FRICTION LATCH

2,659,620

Filed Oct. 16, 1950

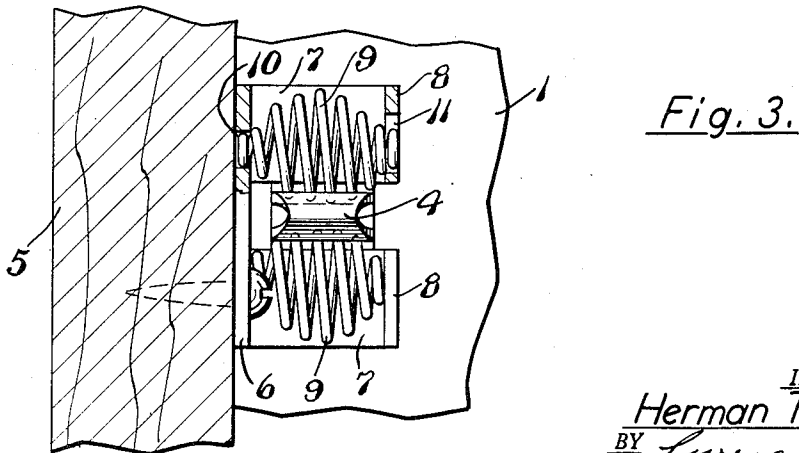
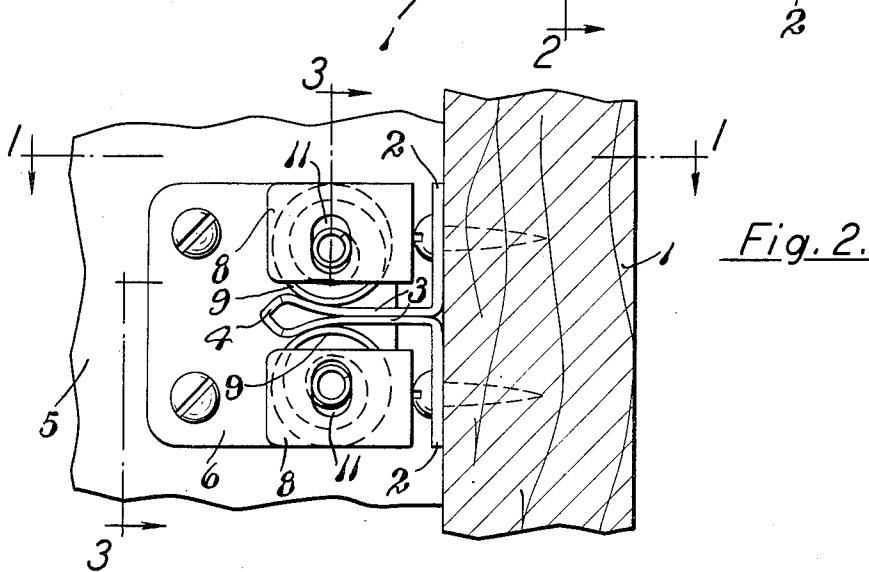
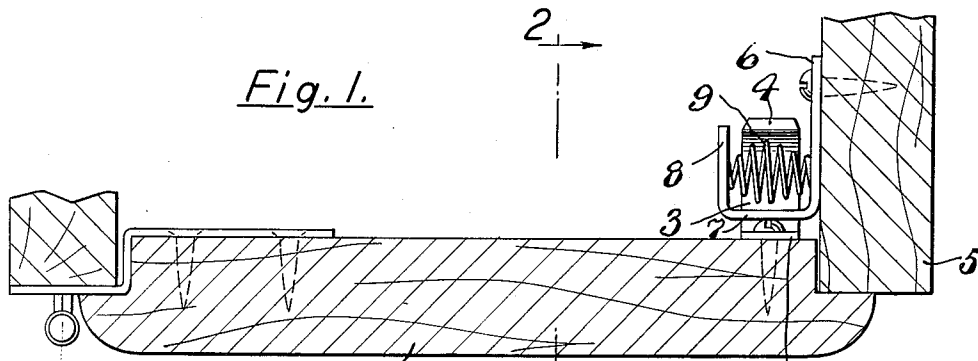

INVENTOR.
Herman Ter Meer
BY *Lucas and Van Antwerp*
Attorneys

UNITED STATES PATENT OFFICE

2,659,620

FRICITION LATCH

Herman Ter Meer, Grand Rapids, Mich., assignor
to National Brass Company, Grand Rapids,
Mich., a corporation of Michigan

Application October 16, 1950, Serial No. 190,271

4 Claims. (Cl. 292—15)

1

This invention relates to a particularly simple, novel and effective friction latch, ordinarily used on lightweight doors, and the doors of cupboards, kitchen cabinets and the like, though not limited thereto.

It is an object and purpose of the present invention to provide a latch which will automatically engage with a keeper or strike therefor to yieldingly hold a door in a closed position, which may be readily opened by an outward pull upon the door, the latch being very simple in structure, economical to produce and effective in use.

An understanding of the invention may be had from the following description, taken in connection with the accompanying drawing, in which,

Fig. 1 is a horizontal section and plan view, the plans of the section being that indicated by the line 1—1 of Fig. 2, through a door and an adjacent side of a casing upon which the latch structure is mounted, showing the door in closed position.

Fig. 2 is a vertical section and side elevation, the section being upon the plane of line 2—2 of Fig. 1 and,

Fig. 3 is a generally vertical section and partial side elevation upon the plane of the broken line 3—3 of Fig. 2, all views being taken in the directions indicated by the arrows associated with the section lines.

Like reference characters refer to like parts in the different figures of the drawing.

The door 1, adapted to be hingedly connected at one vertical edge to a side of a kitchen cabinet or other similar article of furniture, at its inner side and adjacent its free vertical edge has a latch keeper or strike mounted thereon which, as shown, preferably is made from a single length of flat metal which is bent midway between its ends, terminates at both ends thereof in oppositely extending flanges 2 which may be screw attached at the inner side of the door. Said flanges at adjacent edges have sections 3 which lie alongside each other at right angles to the flanges 2, and are integrally connected by the head portion 4 of the strike of the form shown, the sections 3 being curved away from each other and then directed angularly toward each other to provide a head having angular sides diverging away from the integral bend connecting the sections 3 for a distance, and then reversely curved as shown.

The strike at the rear side of the door is adapted to engage with the novel latch mechanism of my invention secured at the inner side of the adja-

2

cent side or end of the cabinet, cupboard or the like with which the invention is used. The latch structure includes a flat base plate 6, to be screw connected at the inner side of the end 5 of the cabinet, and which at its edge nearest the door is extended in two spaced sections 7 at right angles to the plate 6 and parallel to the inner side of the door. Said sections 7 terminate in return bent sections 8 spaced from and parallel to the plate 6. The metal is cut away to provide space between the adjacent edges of the sections 7 and 8 so that the strike may pass between them when the door is closed.

Between each of the terminal sections 8 and the base plate 6 a coiled spring 9 is located and held. Spring 9 has its largest coil midway between its ends, and from such largest coil, the coils progressively decrease in diameter toward and to the ends of the springs. In the base plate 6 circular openings 10 are made into each of which one end coil of each of the springs 9 is received. Each of the sections 8 at the opposite ends of the associated springs has a somewhat elongated slot 11 therein, the width of which is slightly greater than the diameter of the end coil of the spring 9 received therein. The length of the slots 11 is parallel to the base plate 6. Because of the progressively increasing diameter of the coils from the smallest end coils toward the largest middle coil of the springs, only the end coils of the springs are receivable in the circular openings 10 and the slots 11, the next adjacent coils being too large in diameter for entering said openings and slots and, therefore, bearing against the sides of the base plate 6 and the sections 8 as shown in Fig. 3.

The springs 9 normally have their longitudinal axes parallel to each other, with the end coils of said springs in the slots 11 at the ends thereof nearest the adjacent edges of said sections 8. When a door is closed the head 4 passing between the springs engages them and moves them at the ends which are in the slots 11 away from each other so that the axes of the springs 9 diverge away from the side 5 of the cabinet to which the latch is attached until the opposite ends of the slots 11 are reached by the end coils of the springs located therein, whereupon, if necessary, the intermediate coils of the springs 9 may yield and separate for the passage of the head 4 of the strike or keeper until such head passes between said springs and, at the curved portions of the sections 3, the intermediate coils of the spring and particularly, the coils of largest diameter thereof press against opposite sides of the strike,

3

On opening the door a pull applied to a handle attached to the door will swing the springs at the ends thereof located in the slots 11 away from each other with the same divergence of the axes of the springs until the keeper has passed by them, whereupon the springs return to their normal position with axes parallel to each other. The action of the latch is soft and easy, both closing and opening the door being easily accomplished.

The structure of latch described is of a very practical, effective, simple and economical form. For the whole latch assembly there is required merely two pieces of flat metal and two duplicate springs. The assembly of the springs with the base plate 6 and the sections 8 is by merely inserting one end of each spring into its receiving opening 10 and compressing the springs until the other end coil of each spring is received in its cooperating slot 11; or such steps of assembly may be reversed.

The invention is defined in the appended claims and is to be considered comprehensive of all forms of structure coming within their scope.

I claim:

1. A structure of the class described comprising, a support and two coiled springs having end coils of smallest diameter, the other coils of the springs being larger in diameter, circular openings in the support of a diameter substantially equal to the diameter of said end coils of said springs into which like end coils of said springs are received and held, whereby the longitudinal axes of the spring are substantially parallel to each other, elongated openings in the support, said elongated openings having a width equal to the diameter of said circular openings, said elongated openings receiving the other end coils in the springs, the location of said elongated openings being such that on passage of a strike between said springs, the last mentioned end coils traverse said elongated openings and the axes of said springs diverge.

2. A structure as defined in claim 1, the coils of the springs next to said end coils bearing against said support around said circular openings and across said elongated openings therein.

3. In a structure of the class described, a support having connected spaced parallel members,

4

one of said members having two circular openings therein spaced from each other, and the other of said members having two elongated openings spaced from each other, said elongated openings having a width substantially equal to the diameter of said circular openings, two coiled springs each having an end coil snugly received in a circular opening and having an opposite end coil received in an elongated opening, the coils of said springs between the end coils being of larger diameter than the end coils.

4. A latch structure adapted to have detachable engagement with a keeper comprising: a base plate, two spaced outwardly extending sections extending from an edge of the base plate, substantially at right angles thereto and terminating in end sections spaced from and parallel to the base plate, adjacent ends of said first mentioned end terminal sections being spaced from each other, and two coil springs, each having end coils of smaller diameter, the coils of the springs progressively increasing in diameter from each end coil to an intermediate coil, mounted with their axes in generally parallel relation, said base plate having two openings, each of said openings having a diameter approximately equal to the diameter of the end coil of one of the said springs, an end coil of one of said springs being received into each opening, such end coils being held against movement, and each of said terminal sections having a slot therein of width greater than said end coils and smaller than the remainder of said coils of said springs, said slots each receiving an opposite end coil of a spring, such last mentioned end coils being movable lengthwise of the slots for angular change of the longitudinal axes of said springs when a keeper is passed between them, whereby the longitudinal axes of these springs diverge away from said base plate.

HERMAN TER MEER.

References Cited in the file of this patent

UNITED STATES PATENTS

Number	Name	Date
2,317,277	Knuth	Apr. 20, 1943
2,499,818	Dedricks	Mar. 7, 1950
2,559,145	Borchers	July 3, 1951