

G. A. SABINE.
BURGLAR ALARM.
APPLICATION FILED AUG. 5, 1910.

1,000,847.

Patented Aug. 15, 1911.

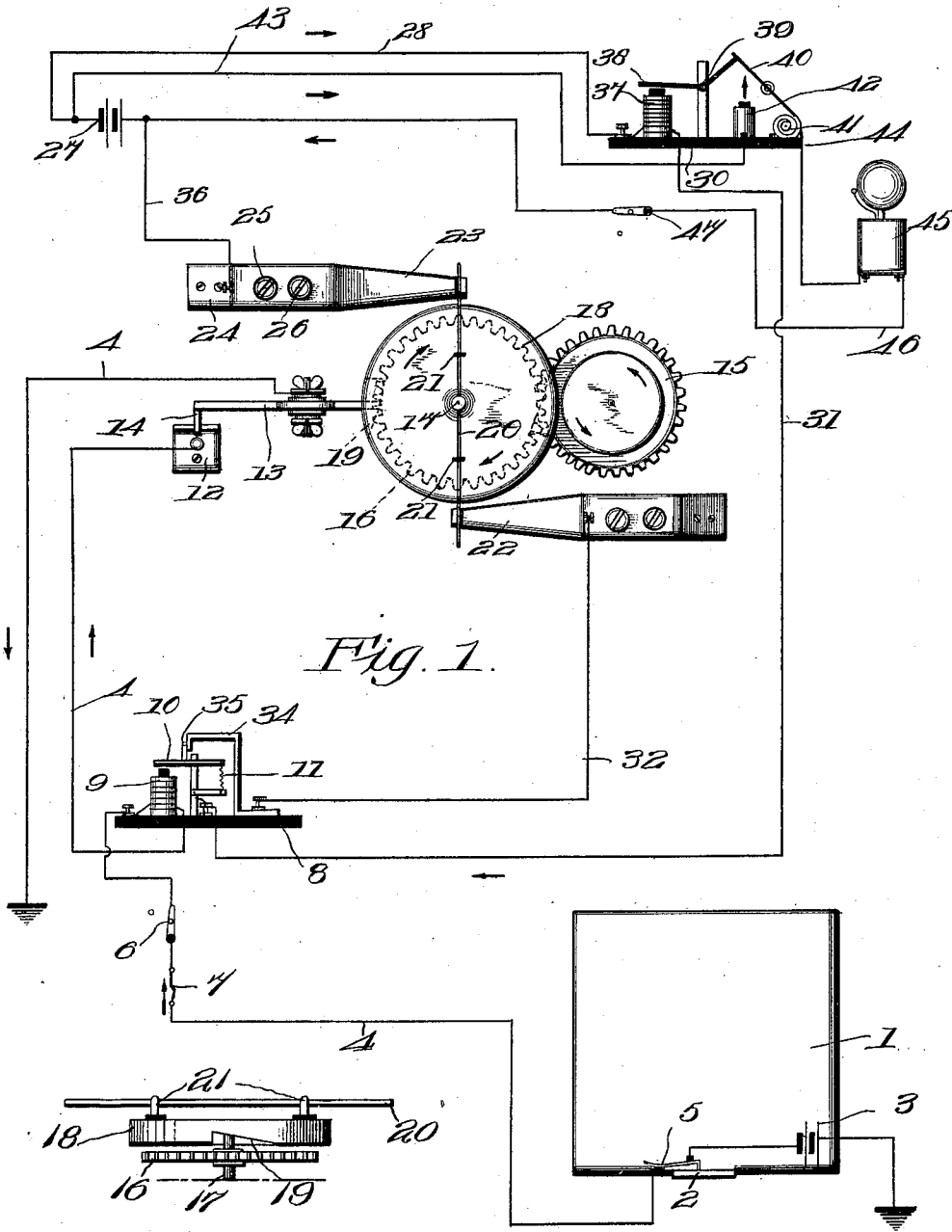

Witnesses
Jas. E. Dodge.
H. b. Lodge.

Inventor
Gustavus A. Sabine,
by Wilkinson, Fisher & Witherspoon.
Attorneys

UNITED STATES PATENT OFFICE.

GUSTAVUS A. SABINE, OF ROBINSON, MARYLAND.

BURGLAR-ALARM.

1,000,847.

Specification of Letters Patent. **Patented Aug. 15, 1911.**

Application filed August 5, 1910. Serial No. 575,835.

To all whom it may concern:

Be it known that I, GUSTAVUS A. SABINE, a citizen of the United States, residing at Robinson, in the county of Anne Arundel and State of Maryland, have invented certain new and useful Improvements in Burglar-Alarms; and I do hereby declare the following to be a full, clear, and exact description of the invention, such as will enable others skilled in the art to which it appertains to make and use the same.

My invention relates to improvements in burglar alarms and is especially adapted to furnish an automatically acting signaling device adapted for use with distant buildings and to give an alarm at the central station.

It is especially valuable for farmers' use, so that the various out-buildings, as well as the house itself, may be all connected up in a general alarm system.

With these objects in view, my invention consists in the construction and combinations of parts as hereinafter described and claimed.

In the accompanying drawings, Figure 1 is a diagrammatic view, showing my invention, and Fig. 2 is a side elevation of the rotary disk.

1 represents an out-building which it is desired to protect, provided with a door 2. Within this building is a battery 3. The circuit from the battery 3 passes through the main line wire 4 and is connected to the door by contacts, as shown at 5, so that the opening of the door will break the circuit.

The wire 4 is preferably provided with a switch 6 and a fuse plug 7 of ordinary construction. From the switch, the wire 4 passes to a binding post on the base 8 of an ordinary telegraphic instrument, and to a magnet 9, having an armature 10, normally held by the spring 11 out of contact with the magnet. From the magnet 9 of the telegraphic instrument, the wire 4 passes to a contact block 12 and thence through a movable arm 13, and finally to ground. The movable arm 13 is provided with a weight 14 at one end, which normally tends to fall and strike the block 12, thus completing the circuit through the main wire 4.

15 represents a gear wheel, meshing with another gear wheel 16. The gear wheel 15 may be the gear wheel of an eight-day clock, for example, or it may be driven by

any suitable power, as by a small water motor, for example. On the shaft 17 of the gear wheel 16 is mounted a disk 18, and this disk on its lower face is provided with a cut away portion 19, two of said cut away portions being preferably provided, located opposite to each other. One end of the arm 13 is adapted to contact with the under side of the disk 18 and when, as said disk moves, the end of this arm comes to the cut away portion 19, the weight 14 pulls the arm down and strikes the contact block 12, whereupon the circuit through the main wire is completed, giving a clicking noise on the telegraphic instrument. The apparatus is so arranged that these clicks may occur at any desired space of time, as two a minute or less frequently, if desired.

On the face of the disk 18, is secured a wire or metal strip 20, insulated from said disk by the holders 21. The ends of this wire are adapted to momentarily contact with the ends of spring contact arms 22 and 23, located on either side of the disk 18. These arms are held in a base plate 24 by means of screws 25, and the ends thereof are adjustable by means of screws 26, so that contact will not be made between the ends of the wire or strip 20 and the arms 22 and 23 except on the very ends of said arms.

27 represents a battery, which is connected up with the arms 22 and 23 and also with a signal apparatus, as hereinafter described.

28 represents the second circuit wire leading from the battery 27 and which passes to a plate 30 and to a binding post on an electro-magnet 37 thereon. A wire 31 leads from the magnet 37 back to form a circuit with the armature 10 of the telegraphic instrument.

34 represents a bent arm on the base plate 8, and the armature 10 is provided with a contact piece 35, so that the spring 11 will ordinarily hold the circuit closed above the base plate 8. A wire 32 leads from the bent arm 34 to the contact arm 32. From the contact plate 23 runs a wire 36 back to the battery 27, the wires 28, 31, 32, and 36 constituting, with the intermediate connections, the second circuit. There is still a third circuit, which acts to ring a bell, or otherwise give an alarm, and this is brought into effect by the operation of the second circuit in the following manner:—38 represents a bent armature, pivoted at 39 on a

suitable post projecting from the plate 30. The other end of said armature is adapted to engage a plate 40, which is normally forced downward by the tension of the spring 41, if it were not prevented from so moving by said armature. 42 represents a contact post on the plate 30. 43 represents a wire leading from the battery 27 to the contact post 42, and 44 represents a wire leading from the spring 41 to an alarm bell 45 of the usual type, and from this signaling device, which may be a bell or any other suitable means of giving a signal, a wire 46, preferably provided with a switch 47, although this is not necessary, leads back to the battery.

The operation is as follows:—As the disk 18 revolves under the influence of the clock-work or similar driving mechanism, twice during every revolution the cut away portion 19 comes over the end of the lever 13, whereupon the weight 14 falls against the contact block 12, thus completing the main circuit if the door 2 has not been opened, the circuit running from the battery 3 through the wire 4, the magnet 9 of the telegraphic instrument, the contact block 12, arm 13, and wire 4, back to the ground. If then the door is closed, this gives clicks at regular intervals and the battery 27 and the parts operated thereby are all this time entirely inoperative. If, however, the door 2 should be opened the main circuit is broken and the magnet 9 will not attract the armature 10. The wire 20, twice during each revolution, will touch the ends of the contact plates 23 and 22 thereby closing the second circuit, the current momentarily passing from the battery 27 through the wire 23, the magnet 37, the wire 31, the armature 10 and contact piece 35 carried thereby and the part 34 of the telegraphic instrument, the wire 32, the contact plate 22, the strip or wire 20, the contact plate 23, and the wire 36, back to the battery 27. The closing of the second circuit is, however, only instantaneous, because the magnet 37 immediately attracts the armature 38, releasing the plate 40, which under the influence of the spring 41 falls down and strikes the contact post 42, breaking the second circuit and completing the third circuit, the current then passing through the wire 43, contact post 42, plate 40, wire 44, signaling device 45, and wire 46, back to the battery. The third circuit will continue to operate the signaling device until it has been reset; that is to say, until the plate 40 has been lifted by hand and the end thereof supported by the end of the armature 38. It will thus be seen that as long as the protected buildings have not been tampered with, the central apparatus will give clicks at regular intervals like a telegraphic instrument, the rest of the apparatus being entirely inoperative. Should,

however, any one of these buildings be opened or tampered with, an alarm will at once be given by the signaling device. In case of several buildings, an annunciator may be used, showing just which building has been tampered with.

While I have thus described my invention, I wish it to be distinctly understood that I do not limit myself to the exact details shown and described, as these could be varied widely without departing from the spirit of my invention.

This invention was primarily designed for a burglar alarm, but obviously the same may be used in any other form of signaling devices. The rotating part may be operated by a clock, by electric power, water power, or any other desired way. The gist of the invention is that the alarm devices are in a normally open circuit, so that the battery operating them will not run down, and that the apparatus when set will give a constant and periodic indication that it is not out of order. If the device gets out of order from a defect in the apparatus, or because some of the protected buildings are tampered with, an alarm is instantly given, which alarm continues until the apparatus is reset. The details of the make and break mechanism, both in the primary as well as the secondary and tertiary circuits, may be varied almost indefinitely.

The advantages of this system are that in the main circuit, the current being intermittent, only a minimum supply is used. When set, it gives a periodic indication showing that the apparatus is in good order, and that the protected buildings have not been tampered with. If the main circuit gets out of order for any reason, as for instance by the batteries running down, an alarm will at once be given. If the main signal wire is cut, crossed or grounded, it will also give an alarm. It prevents the cutting of the wires by persons in collusion with burglars to throw the apparatus out of commission. As a light current is used, the wire can be strung anywhere without damage, doing away with the heavy cost of an underground cable, etc.

Having thus described my invention, I claim:—

1. In an alarm system, the combination of a normally open main circuit and devices for closing the same at regular intervals, said devices including a pivoted weighted arm, a revolving disk with which one end of said arm contacts, said disk being provided with a cut away portion to allow said arm to drop, and means for rotating said disk, substantially as described.

2. In an alarm system, the combination of a normally open circuit having therein signaling means, an alarm, devices for closing the circuit at regular intervals for operating

the signaling means, and means for operating the alarm when the signaling means fails to act, substantially as described.

3. In an alarm system, the combination of a
5 normally open main circuit, signaling means arranged in the main circuit, means for closing the main circuit at regular intervals to operate the signaling means, a secondary circuit adapted to be brought into action by
10 failure of the main circuit to act, and a third circuit including an alarm brought into action by the action of the second circuit to sound the alarm, substantially as described.

4. In an alarm system, the combination of
15 a main circuit having therein signaling means, means for intermittently opening and closing said main circuit for operating the signaling means at regular intervals, a secondary circuit normally open and intermit-
20 tently closed when the main circuit fails to operate the signaling means, and a third circuit including an alarm device, normally open but closed by the closing of the second circuit to actuate said alarm device, substan-
25 tially as described.

5. In an alarm system, the combination of a main circuit including an electric device for giving notice at regular intervals that the apparatus is in order, a second circuit including a rotary disk, a pivoted contact
30 arm arranged in the main circuit and controlled by the rotary disk, a rod carried by said rotary disk, contact arms adapted to be engaged by the rod for momentarily closing
35 the second circuit, said second circuit including an electro-magnet provided with an armature and a spring operated contact plate pressed in engagement with said arma-
40 ture, and a third circuit including an alarm and a contact post adapted to be engaged by the spring contact plate when the second circuit is closed for closing the third circuit to sound the alarm, substantially as de-
scribed.

In testimony whereof, I affix my signa- 45
ture, in presence of two witnesses.

GUSTAVUS A. SABINE.

Witnesses:

J. A. WALTON,
G. W. MINER.