

(19)



(11)

EP 4 174 414 B1

(12)

EUROPEAN PATENT SPECIFICATION

(45) Date of publication and mention of the grant of the patent:
02.04.2025 Bulletin 2025/14

(51) International Patent Classification (IPC):
F25D 23/00^(2006.01) F25D 11/02^(2006.01)
F25D 23/10^(2006.01)

(21) Application number: **21857477.0**

(52) Cooperative Patent Classification (CPC):
F25D 23/003; F25D 23/006; F25D 23/10

(22) Date of filing: **29.07.2021**

(86) International application number:
PCT/CN2021/109163

(87) International publication number:
WO 2022/037382 (24.02.2022 Gazette 2022/08)

(54) **EMBEDDED REFRIGERATOR**

EINGEBETTETER KÜHLSCHRANK

RÉFRIGÉRATEUR INTÉGRÉ

(84) Designated Contracting States:
AL AT BE BG CH CY CZ DE DK EE ES FI FR GB GR HR HU IE IS IT LI LT LU LV MC MK MT NL NO PL PT RO RS SE SI SK SM TR

- **LI, Weijie**
Qingdao, Shandong 266101 (CN)
- **LIU, Lei**
Qingdao, Shandong 266101 (CN)

(30) Priority: **18.08.2020 CN 202010833852**

(74) Representative: **Ziebig Hengelhaupt Intellectual Property Attorneys**
Patentanwaltskanzlei PartGmbB
Leipziger Straße 49
10117 Berlin (DE)

(43) Date of publication of application:
03.05.2023 Bulletin 2023/18

- (73) Proprietors:
- **Qingdao Haier Refrigerator Co., Ltd.**
Laoshan District
Qingdao
Shandong 266101 (CN)
 - **Haier Smart Home Co., Ltd.**
Qingdao, Shandong 266101 (CN)

- (56) References cited:
- | | |
|----------------------------|----------------------------|
| EP-A1- 2 743 618 | EP-A1- 3 447 414 |
| WO-A1-2009/141117 | CN-A- 1 467 465 |
| CN-A- 103 189 693 | CN-A- 108 413 686 |
| CN-A- 110 375 482 | CN-A- 110 375 506 |
| CN-A- 110 375 507 | CN-A- 110 375 508 |
| CN-U- 202 511 546 | CN-U- 208 688 080 |
| CN-U- 208 817 830 | CN-U- 208 817 832 |
| CN-U- 208 817 833 | CN-U- 209 893 736 |
| CN-U- 210 036 003 | DE-A1- 19 746 962 |
| JP-A- 2012 202 567 | JP-A- H10 334 327 |
| KR-A- 20060 120 752 | KR-A- 20100 062 019 |
| US-A- 5 881 567 | |

- (72) Inventors:
- **MA, Jian**
Qingdao, Shandong 266101 (CN)
 - **ZHU, Xiaobing**
Qingdao, Shandong 266101 (CN)

EP 4 174 414 B1

Note: Within nine months of the publication of the mention of the grant of the European patent in the European Patent Bulletin, any person may give notice to the European Patent Office of opposition to that patent, in accordance with the Implementing Regulations. Notice of opposition shall not be deemed to have been filed until the opposition fee has been paid. (Art. 99(1) European Patent Convention).

Description**FIELD OF THE INVENTION**

[0001] The present disclosure relates to an embedded refrigerator.

BACKGROUND OF THE INVENTION

[0002] In order to solve the problem of heat dissipation, most of the embedded refrigerators in the prior art choose to set an air outlet and an air inlet at a bottom of a refrigerator body, and form a heat dissipation air flow by means of a heat dissipation fan to carry out heat dissipation on a condenser.

[0003] The air outlet and the air inlet in the existing solution are generally provided in a front surface of the refrigerator, while a compressor compartment is disposed at a rear portion of the refrigerator body, which greatly extends the length of the heat dissipation air flow and reduces the air dispersion efficiency. Furthermore, since the air outlet and the air inlet are located in the front surface of the refrigerator body, the appearance of the refrigerator will also be affected.

[0004] JP 2012 202567 A discloses how to provide a refrigerator having improved efficiency of energy by improving the cooling performance of a compressor in the refrigerator. The refrigerator includes a cooling fan which cools a compressor provided in a rear lower part of a refrigerator body, and a partition plate which is projected in a floor direction from a bottom plate of the refrigerator body to extend in front-rear directions, and which partitions the space between the bottom plate and a floor surface into right and left part when viewed from the front, the partition plate being arranged in parallel with side surfaces of the refrigerator so that air energized by the cooling fan flows including a side part of the refrigerator body such that one of the right and left side is a suction-side air course and the other side is an exhaustion-side air course.

[0005] DE 19746962A1 discloses a cooling or freezing apparatus that has a first channel for guiding in ambient air and a second channel for guiding away the ambient air to separate the first channel from the second channel, a variable separating part is provided. The first channel and the second channel are located in the bottom group of the apparatus. The first channel opens out in the second channel to a channel system and in this channel system, a coolant liquefier and a fan are located. The separating part is fastened to a base grille and lies on a floor-pan under spring force. The separating part is folded in zigzag fashion.

[0006] CN 110375482 A discloses a refrigerator capable of dissipating heat from the bottom. The refrigerator comprises a refrigerator body, a door body and a refrigeration system, wherein a compressor bin and a storage space are defined inside the refrigerator body, the compressor bin is arranged at the rear side of the bottom of

the refrigerator body, and the compressor bin is in communication with an external space below the refrigerator body through a heat dissipation air inlet and a heat dissipation air outlet which are transversely arranged at the bottom of the refrigerator body side by side; the door body is arranged on the front surface of the refrigerator body so as to be operable to open and close the storage space; and the refrigeration system is configured to provide a cold energy to the storage space, comprises a condenser, a heat dissipation fan and a compressor sequentially arranged in the compressor bin along the transverse direction, wherein the condenser is arranged on the side close to the heat dissipation air inlet, the compressor is arranged on the side close to the heat dissipation air outlet, so that air outside the refrigerator enters the compressor bin through the heat dissipation air inlet, and sequentially passes through the condenser, the heat dissipation fan and the compressor and then is discharged through the heat dissipation air outlet so as to dissipate heat of the compressor bin.

[0007] CN 202511546 U discloses a refrigerator, in particular a refrigerator provided with heat insulating parts. The refrigerator provided with the heat separating part aims at solving the problems that refrigeration efficiency of the refrigerator is influenced and electric quantity is increased due to reflux of hot air caused by unreasonable design of the refrigerator at present. The heat insulating parts are additionally arranged on a rat-prevention plate, a base plate and a chassis of the refrigerator so as to stop the air flowing between an air inlet and an air outlet. Hot air subjected to heat exchange in a mechanical chamber is effectively prevented from being discharged from an air vent on one side and enters the mechanical chamber again by aid of air reflux at the positions of the base plate and a wall.

[0008] CN 1101375506 A discloses a delay-locked loop that includes: an adjustable frequency source for generating a clock signal having an adjustable frequency; an adjustment and tap selection controller for determining a first frequency as a function of a second frequency and for causing the frequency source to adjust the frequency of the clock signal to substantially the first frequency, the second frequency being the desired frequency of a first output signal; a delay line configured to receive the clock signal for generating a plurality of phase-shifted clock signals; and a first selection circuit for receiving the plurality of phase-shifted clock signals and for selecting, one at a time and under the control of the adjustment and tap selection controller, a first sequence of the phase-shifted clock signals for generating the first output signal having substantially the second frequency.

BRIEF DESCRIPTION OF THE INVENTION

[0009] An object of the present disclosure is to provide an embedded refrigerator that solves at least any aspect of the above-mentioned problems.

[0010] A further object of the present disclosure is to improve the heat dissipation efficiency of the embedded refrigerator.

[0011] Another further object of the present disclosure is to avoid damage to an air shielding strip during transportation.

[0012] The present invention is defined by the embedded refrigerator of independent claim 1. In the following, in case parts of the description and drawing referring to embodiments, which are not covered by the claims are not presented as embodiments of the invention, but as examples useful for understanding the invention.

[0013] The present invention provides an embedded refrigerator, which includes: a refrigerating system, including a compressor and a condenser connected to the compressor; a refrigerator body, a compressor compartment being disposed at a rear of a bottom thereof, the compressor and the condenser being disposed in the compressor compartment at an interval in a transverse direction of the refrigerator body, and a bottom wall of the compressor compartment being provided with an air flow suction inlet in front of the condenser, and provided with an air flow exhaust outlet in front of the compressor; a heat dissipation fan, disposed between the compressor and the condenser to facilitate the formation of a heat dissipation air flow that enters from the air flow suction inlet and flows through the condenser for heat exchange, and is then discharged to the air flow exhaust outlet through the compressor; and an air shielding strip, disposed on a lower surface of the refrigerator body, a middle portion of the air shielding strip being a flexible section that can be bent under a force, such that the air shielding strip is in an air shielding state by bending the flexible section, and in the air shielding state, the air shielding strip divides a space between a lower part of the refrigerator body and a ground supporting the refrigerator into an air inlet area communicated with the air flow suction inlet and an air outlet area communicated with the air flow exhaust outlet.

[0014] Further, the bottom wall of the compressor compartment includes: a compressor support plate, disposed at a rear portion of the bottom wall; an air inlet plate, extending forward from a front end of an area where the condenser is located in the compressor support plate, the air flow suction inlet being formed in the air inlet plate; and an air outlet plate, extending forward from a front end of an area where the compressor is located in the compressor support plate, the air flow exhaust outlet being formed in the air outlet plate, and the air shielding strip extending linearly along a front end of the compressor support plate when the flexible section is not bent.

[0015] Further, the air shielding strip includes: a first shielding section, fixed between the front end of the compressor support plate and the air inlet plate; the flexible section, one end of which is connected to an end, positioned at a middle portion of the refrigerator body, of the first shielding section; and a second shielding section, connected to the other end of the flexible section,

disposed in an area in front of the compressor, and changing an extension direction according to a bending degree of the flexible section.

[0016] Further, when the air shielding strip is in the air shielding state, the flexible section is bent into an arc shape, and the second shielding section extends obliquely forward from a position between the air inlet plate and the air outlet plate with an inclination direction from back to the front biased towards a side where the compressor is positioned.

[0017] Further, the refrigerator further includes a partition, disposed between the air inlet plate and the air outlet plate, used to separate an area in front of the compressor and an area in front of the condenser in the compressor compartment, and including: a bottom plate, positioned between the air inlet plate and the air outlet plate; a first side plate, extending upward from an end, close to the air outlet plate, of the bottom plate to isolate the area in front of the compressor; and a second side plate, extending upward from an end, close to the air inlet plate, of the bottom plate to isolate the area in front of the condenser, where a lower surface of the bottom plate is provided with a claw for fixing the second shielding section, so as to limit the position of the second shielding section when the air shielding strip is in the air shielding state.

[0018] Further, a limit slot adapted to the shape of a front end of the heat dissipation fan is formed in a rear end wall of the first side plate for accommodating a front portion of the heat dissipation fan, and the heat dissipation fan extends from a rear portion of the first side plate to a position between the compressor and the condenser.

[0019] Further, the refrigerator further includes an air deflector, extending from the first side plate to a front of the compressor to allow the heat dissipation air flow flowing through the compressor to flow from a side away from the first side plate to the air flow exhaust outlet, a projection of a tail end of the air deflector in a depth direction of the refrigerator body being aligned with a middle portion of the compressor.

[0020] Further, a cross section of the air shielding strip is L-shaped, where a horizontal side edge of the air shielding strip is attached to the lower surface of the refrigerator body, a vertical side edge of the air shielding strip is perpendicular to the lower surface of the refrigerator body, and the height of the vertical side edge matches the height from the lower surface of the refrigerator body to the ground supporting the refrigerator.

[0021] Further, grilles are respectively formed at the air flow suction inlet and the air flow exhaust outlet to prevent foreign matters from entering the refrigerator body.

[0022] Further, the condenser is cuboid in an overall shape, and is installed to allow its radiating fins to extend along the depth direction of the refrigerator body, so that the air entering from the air flow suction inlet flows to the compressor through passages between the radiating fins.

[0023] The embedded refrigerator of the present disclosure is provided with the air flow suction inlet and the

air flow exhaust outlet on the lower surface of the refrigerator body, air below the refrigerator body is utilized to implement convective heat dissipation with the compressor compartment, so that a heat dissipation channel is short, and the heat dissipation effect is better. Moreover, the embedded refrigerator of the present disclosure is provided with the air shielding strip, and the air shielding strip has the flexible section, which can isolate the air flow suction inlet from the air flow exhaust outlet by bending, so as to prevent the heat dissipation air flow from circulating within a small range at the bottom of the refrigerator body, and further improve the heat dissipation efficiency.

[0024] Further, in a transportation process of the embedded refrigerator of the present disclosure, when the flexible section of the air shielding strip is not bent, the air shielding strip can extend linearly along the front end of the compressor support plate, which is convenient to cooperate with a packaging box during transportation, thus reducing the risk of collision damage.

[0025] Furthermore, the embedded refrigerator of the present disclosure improves the layout of parts in the compressor compartment, so as to facilitate the heat dissipation of the condenser and the compressor compartment. In addition, because the bottom of the partition is used for clamping the air shielding strip, the installation convenience is also improved.

[0026] The above and other objects, advantages and features of the present disclosure will be more apparent to those skilled in the art from the following detailed description of the specific embodiments of the present disclosure in conjunction with the accompanying drawings.

BRIEF DESCRIPTION OF THE DRAWINGS

[0027] Hereinafter, some specific embodiments of the present disclosure will be described in detail in an exemplary rather than restrictive manner with reference to the accompanying drawings. The same reference numerals in the accompanying drawings indicate the same or similar components or parts. Those skilled in the art should understand that these accompanying drawings are not necessarily drawn to scale. In figures:

FIG. 1 is a schematic front view of an embedded refrigerator according to an embodiment of the present disclosure;

FIG. 2 is a schematic side sectional view of the embedded refrigerator shown in FIG. 1;

FIG. 3 is a schematic three-dimensional diagram of a compressor compartment in the embedded refrigerator shown in FIG. 2, in which a compressor compartment cover plate is hidden;

FIG. 4 is a schematic bottom view of the compressor compartment in the embedded refrigerator shown in FIG. 3, which shows an air shielding state of an air shielding strip;

FIG. 5 is still a schematic bottom view of the com-

pressor compartment in the embedded refrigerator shown in FIG. 3, which shows a received state of the air shielding strip;

FIG. 6 is a schematic exploded view of the compressor compartment in the embedded refrigerator shown in FIG. 3;

FIG. 7 is a schematic three-dimensional diagram of a partition in an embedded refrigerator according to an embodiment of the present disclosure; and

FIG. 8 is a schematic bottom view of the partition in the embedded refrigerator shown in FIG. 7.

DETAILED DESCRIPTION

[0028] In the description of this embodiment, it should be understood that the orientations or the positional relationships indicated by the terms 'transverse', 'upper', 'lower', 'front', 'back', 'top', 'bottom', 'depth', etc. are based on the orientation of a refrigerator under a normal use status as reference, and can be determined with reference to the orientations or the positional relationships shown in the accompanying drawings. For example, 'front' indicating the orientation refers to a side of the refrigerator facing a user, and 'transverse' refers to a direction parallel to the width direction of the refrigerator. This is only to facilitate the description of the present disclosure and to simplify the description, and is not intended to indicate or imply that the device or element referred to must have a particular orientation and be constructed and operated in a particular orientation, and therefore should not be construed as a limitation of the present disclosure.

[0029] FIG. 1 is a schematic front view of an embedded refrigerator according to an embodiment of the present disclosure. FIG. 2 is a schematic side sectional view of the embedded refrigerator shown in FIG. 1. The refrigerator may generally include a refrigerator body 10, and the refrigerator body 10 includes a housing, a liner and other accessories. The housing is an outer structure of the refrigerator and protects the entire refrigerator. In order to isolate the heat conduction with the outside, a heat insulating layer is additionally disposed between the housing and the liner of the refrigerator body 10, and the heat insulating layer is generally formed by a foaming process. The liner can be divided into one or more, and the liner can be divided into a refrigerating liner, a variable temperature liner, a freezing liner and the like according to the functions. The specific number and functions of liners can be configured according to the use requirements of the refrigerator. In the embodiment, the liner at least includes a bottom liner 101, and the bottom liner 101 can generally be the freezing liner.

[0030] The bottom liner 101 is the liner at the bottom-most part of the refrigerator body 10, and defines a storage space 300 and a cooling chamber 100 located below the storage space 300. An evaporator 60 may be disposed in a middle front portion of the cooling chamber 100 slantingly upward from front to back along the depth

direction of the refrigerator body. A bottom wall of the bottom liner 101 has a liner tilt portion, which is inclined upward from front to back, at a rear portion of the cooling chamber 100, and a tilt angle range is set to 30° to 40°, for example, the tilt angle can be set to be 33°, 35° or 38°, preferably 36.7°, thus providing a sufficient space for a compressor compartment 200. The storage space 300 can generally be used as a freezing space of the refrigerator.

[0031] The embedded refrigerator includes a refrigerating system. The refrigerating system includes a throttling element (not shown in the figures), the evaporator 60, a refrigeration fan 40, a compressor 20 and a condenser 30 connected to the compressor 20. Since the circulation structure and working principle of the refrigerating system itself are well known to those skilled in the art and are easy to implement, in order not to conceal and obscure the improvements of the present application, the refrigerating system itself will not be described in detail below.

[0032] As shown in FIG. 3, the compressor compartment 200 is formed at a rear of a bottom of the refrigerator body 10 in the embodiment. The compressor compartment 200 is defined by a bottom wall 220, a back plate 240 disposed at a rear end of the bottom wall 220, side plates 230 disposed at both ends of the bottom wall 220, and a compressor compartment cover plate 210 disposed above the bottom wall 220. The compressor compartment 200 is internally at least equipped with the compressor 20, the condenser 30 and a heat dissipation fan 50. The compressor 20 and the condenser 30 are disposed in the compressor compartment 200 at an interval in a transverse direction of the refrigerator body 10. In some embodiments, the condenser 30 can be a finned condenser, and fins of the condenser 30 are disposed from front to back along the depth direction of the refrigerator body 10, so that a heat dissipation air flow can pass through gaps between the fins directly, and the contact area with the heat dissipation air flow is therefore enlarged.

[0033] The bottom wall 220 of the compressor compartment 200 is provided with an air flow suction inlet 2220 in front of the condenser 30, and an air flow exhaust outlet 2230 in front of the compressor 20. Grilles are respectively formed at the air flow suction inlet 2220 and the air flow exhaust outlet 2230, that is, the air flow suction inlet 2220 and the air flow exhaust outlet 2230 are communicated with an outside of the refrigerator body 10 by means of ventilation holes formed among the grilles, so that foreign matters (such as small animals) are prevented from entering the refrigerator body 10 through the air flow suction inlet 2220 and the air flow exhaust outlet 2230. The air outside the refrigerator body 10 can enter the compressor compartment 200 from the air flow suction inlet 2220, take away heat from the condenser 30 by exchanging heat with the condenser 30, then enter a side where the compressor 20 is positioned in the compressor compartment 200 through the heat dissipation fan 50 to

take away heat generated by the operation of the compressor 20, and is then discharged outside from the air flow exhaust outlet 2230 so as to achieve the purpose of dissipating heat from equipment in the compressor compartment 200.

[0034] The compressor compartment cover plate 210 of the embodiment includes an inclined front cover 211 and a top cover 212. The inclined front cover 211 is inclined upward from front to back in the depth direction of the refrigerator body 10 from front sides of the air flow suction inlet 2220 and the air flow exhaust outlet 2230. The top cover 212 extends horizontally rearward from a rear end of the inclined front cover 211 until being connected to the back plate 240. That is, the compressor compartment cover plate 210 is inclined to save an internal space of the refrigerator body 10 as much as possible and further increase the volume of the storage space 300 above the compressor compartment 200, thus improving the overall space utilization rate. The projection of the compressor compartment 200 on a horizontal plane is located behind the projection of the evaporator 60 on the horizontal plane, that is, the compressor compartment 200 and the evaporator 60 are placed in a staggered manner in a horizontal direction, which reduces the installation height of the evaporator 60 and increases the volume of the storage space 300.

[0035] The refrigerator includes the heat dissipation fan 50. The heat dissipation fan 50 is disposed between the compressor 20 and the condenser 30 to facilitate the formation of a heat dissipation air flow that enters from the air flow suction inlet 2220 and flows through the condenser 30 for heat exchange, and is then discharged to the air flow exhaust outlet 2230 through the compressor 20. The heat dissipation fan 50 may be an axial flow fan, and its rotation axis is parallel to the transverse direction of the refrigerator body 10. An air inlet side of the heat dissipation fan 50 faces the condenser 30, and an air outlet side thereof faces the compressor 20, and the heat dissipation fan 50 is used to promote the formation of the heat dissipation air flow that enters from the air flow suction inlet 2220 and flows through the condenser 30 for heat exchange, and is then discharged to the air flow exhaust outlet 2230 through the compressor 20. In some embodiments, a bracket and fan blades of the heat dissipation fan 50 can be assembled into an integral structure, and the outer periphery of the bracket of the fan is provided with an assembly structure to be directly fixed with a compartment wall of the compressor compartment 200. It is not necessary to set other brackets for fixing the fan in the compressor compartment 200, so that the structure in the compressor compartment 200 is simpler, the fixing effect is better, and the heat dissipation fan 50 operates more stably.

[0036] According to the refrigerator of the invention, an air shielding strip 280 is disposed on a lower surface of the refrigerator body 10. The air shielding strip 280 is disposed on the lower surface of the refrigerator body 10, and a middle portion of the air shielding strip 280 is a

flexible section 283 that can be bent under a force, such that by bending the flexible section 283, the air shielding strip 280 is in an air shielding state in which the air shielding strip 280 divides a space between a lower part of the refrigerator body 10 and a ground supporting the refrigerator into an air inlet area communicated with the air flow suction inlet 2220 and an air outlet area communicated with the air flow exhaust outlet 2230. The flexible section 283 of the air shielding strip 280 can isolate the air flow suction inlet 2220 from the air flow exhaust outlet 2230 by bending, so as to prevent the heat dissipation air flow from circulating within a small range at the bottom of the refrigerator body 10, and further improve the heat dissipation efficiency.

[0037] As shown in FIG. 4-FIG. 8, the bottom wall 220 includes a compressor support plate 221, an air inlet plate 222, and an air outlet plate 223. The compressor support plate 221 is disposed at a rear portion of the bottom wall 220. The air inlet plate 222 extends forward from a front end of an area where the condenser 30 is located in the compressor support plate 221, and is provided with the air flow suction inlet 2220. The air outlet plate 223 extends forward from a front end of an area where the compressor 20 is located in the compressor support plate 221, and is provided with the air flow exhaust outlet 2230. When the flexible section 283 is not bent, the air shielding strip 280 extends linearly along a front end of the compressor support plate 221. That is, the air shielding strip 280 has two states. In an actual use process, the air shielding strip 280 is in the air shielding state (as shown in FIG. 4), and the air shielding strip 280 is bent to isolate the air flow suction inlet 2220 from the air flow exhaust outlet 2230, so as to avoid the circulation of the heat dissipation air flow in the small range at the bottom of the refrigerator body 10, and improve the heat dissipation efficiency; and during transportation, the air shielding strip 280 is in a received state (as shown in FIG. 5), and extends in a straight line along the front end of the compressor support plate 221, which is convenient to cooperate with a packaging box during transportation and handling, thus avoiding damage caused by collision.

[0038] The air shielding strip 280 includes a first shielding section 281, the flexible section 283, and a second shielding section 282. The first shielding section 281 is fixed between the front end of the compressor support plate 221 and the air inlet plate 222. One end of the flexible section 283 is connected to one end of the first shielding section 281 located in a middle portion of the refrigerator body 10. The second shielding section 282 is connected to the other end of the flexible section 283 and disposed in an area in front of the compressor 20, and changes the extension direction according to a bending degree of the flexible section 283. The first shielding section 281 is always fixed on the lower surface of the refrigerator body 10, and the second shielding section 282 can rotate on the lower surface along with the bending of the flexible section 283 to separate the air flow suction inlet 2220 from the air flow exhaust outlet 2230,

so as to avoid the circulation of the heat dissipation air flow in the small range at the bottom of the refrigerator body 10 and improve the heat dissipation efficiency. In the received state, the second shielding section 282 is fixed between the front end of the compressor support plate 221 and the air outlet plate 223, and cooperates with the packaging box during transportation so as to avoid the damage caused by collision.

[0039] When the air shielding strip 280 is in the air shielding state, the flexible section 283 is bent into an arc shape, and the second shielding section 282 extends obliquely forward from a position between the air inlet plate 222 and the air outlet plate 223 with an inclination direction from back to the front biased towards a side where the compressor 20 is positioned. By cooperating the second shielding section 282 with the lower surface of the refrigerator body 10, the air outlet area is limited to the front side of the refrigerator body 10, so that the heat dissipation air flow can quickly leave the surrounding environment of the refrigerator, and the problem that the hotter heat dissipation air flow is scattered over an accommodation space of the embedded refrigerator after the heat exchange is completed, which causes the environment where the refrigerator is located to be hotter and increases the energy consumption of the refrigerator is therefore avoided. The air inlet area is restricted by the first shielding section 281 to be the other area around the refrigerator body 10 than the air outlet area.

[0040] The air enters the compressor compartment 200 through the air flow suction inlet 2220 communicated with the air inlet area, fully exchanges heat with the condenser 30, then enters the side where the compressor 20 is positioned through the heat dissipation fan 50 to take away the heat generated by the operation of the compressor 20, enters the air outlet area from the air flow exhaust outlet 2230, and then leaves the bottom of the refrigerator body 10.

[0041] A cross section of the air shielding strip 280 is L-shaped, where a horizontal side edge of the air shielding strip 280 is attached to the lower surface of the refrigerator body 10, a vertical side edge of the air shielding strip 280 is perpendicular to the lower surface of the refrigerator body 10, and the height of the vertical side edge matches the height from the lower surface of the refrigerator body 10 to the ground supporting the refrigerator, so as to fully separate the air flow suction inlet 2220 from the air flow exhaust outlet 2230; and therefore, the possibility that the heat dissipation air flow returns from the air flow exhaust outlet 2230 directly to the air inlet area through a gap between the air shielding strip 280 and the supporting ground is reduced, the circulation of the heat dissipation air flow within a small range at the bottom of the refrigerator body 10 is avoided, and the heat dissipation efficiency is improved.

[0042] The refrigerator of the embodiment further includes a partition 270. The partition 270 is disposed upward between the air inlet plate 222 and the air outlet plate 223 to separate an area in front of the compressor

20 and an area in front of the condenser 30 in the compressor compartment 200. The partition 270 includes a bottom plate 276, a first side plate 271 and a second side plate 272. The bottom plate 276 is positioned between the air inlet plate 222 and the air outlet plate 223. The first side plate 271 extends upward from an end, close to the air outlet plate 223, of the bottom plate 276 to isolate the area in front of the compressor 20. The second side plate 272 extends upward from an end, close to the air inlet plate 222, of the bottom plate 276 to isolate the area in front of the condenser 30. The partition 270 isolates the air flow suction inlet 2220 from the air flow exhaust outlet 2230, so that the heat dissipation air flow can only be discharged from the air flow exhaust outlet 2230 through the air flow suction inlet 2220, the condenser 30, the heat dissipation fan 50 and the compressor 20, which makes the heat dissipation more sufficient. A lower surface of the bottom plate 276 is provided with a claw 275 for fixing the second shielding section 282, so as to limit the position of the second shielding section 282 when the air shielding strip 280 is in the air shielding state.

[0043] A limit slot 274 adapted to the shape of a front end of the heat dissipation fan 50 is formed in a rear end wall of the first side plate 271 for accommodating a front portion of the heat dissipation fan 50. By connecting and fixing the partition 270 and the heat dissipation fan 50, all parts in the compressor compartment 200 are more closely connected and more integrated. Moreover, the above installation method using the limit slot 274 is convenient and fast, and simplifies the installation steps of the heat dissipation fan 50. In addition, the heat dissipation fan 50 extends from a rear portion of the first side plate 271 to a position between the compressor 20 and the condenser 30. The compressor compartment 200 is divided into a compressor side and a condenser side by the heat dissipation fan 50 and the partition 270. After fully exchanging heat with the condenser 30, the heat dissipation air flow can enter the compressor 20 side through the heat dissipation fan 50, and can be discharged out of the refrigerator body 10 from the air flow exhaust outlet 2230 only after taking away the heat generated during the operation of the compressor 20.

[0044] According to the embodiment, a drain pipe 110 of the embedded refrigerator extends from a drain outlet at a bottom of the liner above the compressor compartment cover plate 210 to an evaporating dish 250 through an area between the first side plate 271 and the second side plate 272. The arrangement of a reserved opening between the first side plate 271 and the second side plate 272 can effectively save an internal space of the compressor compartment 200, and further make an internal structure of the refrigerator body 10 more compact, thus increasing the overall space utilization rate of the refrigerator.

[0045] The embedded refrigerator of the embodiment is provided with an air deflector 273. The air deflector 273 extends from the first side plate 271 to a front of the compressor 20 to allow the heat dissipation air flow

flowing through the compressor 20 to flow from a side away from the first side plate 271 to the air flow exhaust outlet 2230, and a projection of a tail end of the air deflector 273 in the depth direction of the refrigerator body 10 is aligned with a middle portion of the compressor 20. After the air deflector 273 is disposed in the compressor compartment 200, the heat dissipation space in the compressor compartment 200 will be further compressed for a fully embedded refrigerator, so an end point of the air deflector 273 should not be too long. A starting point of the air deflector 273 is disposed at a position where the heat dissipation fan 50 is located, so as to prevent the diffusion of heat dissipation; and the end point thereof is aligned with the middle portion of the compressor 20, which can guide all the heat dissipation air flow to the whole surface of the compressor 20 to maximize the heat dissipation of the compressor 20, thus preventing the air volume loss when the heat dissipation air flow moves from an initial point to an apex, and further effectively lowering the temperature of the compressor 20. In addition, due to the arrangement of the air deflector 273, the air volume swirl is reduced, the temperature of the condenser 30 is lowered, and effective energy conservation is achieved.

[0046] According to the embodiment, the condenser 30 is cuboid in an overall shape, and is installed to allow its radiating fins to extend along the depth direction of the refrigerator body 10, so that the air entering from the air flow suction inlet 2220 flows along passages between the radiating fins for heat exchange, and then flows to the heat dissipation fan 50 from an interval between the condenser 30 and the back plate 240. The radiating fins are in parallel arrangement along the depth direction. After entering from the air flow suction inlet 2220, the air can smoothly contact and exchange heat with all the fins through gaps between the radiating fins, thus greatly enhancing the heat dissipation effect. In some embodiments, the condenser 30 can be tilted upward from front to back along the depth direction of the refrigerator body 10, which can effectively utilize the air inhaled in the air flow suction inlet 2220 to increase the full contact area between the air and the condenser 30 and enhance the heat dissipation effect. In some other embodiments, the condenser 30 may also use a micro-channel heat exchanger.

[0047] According to the embedded refrigerator of the embodiment, an air guide assembly 290 can also be disposed in the compressor compartment 200. The air guide assembly 290 is disposed at an outer periphery of the condenser 30, and is configured to guide the air inhaled from the air flow suction inlet 2220 to completely cross the condenser 30, so as to avoid the air flow escaping from the outer periphery of the condenser 30, and allow the air flow to flow to the heat dissipation fan 50 only from the interval between the condenser 30 and the back plate 240. The heat dissipation air flow can be enabled to fully contact the condenser 30, so that the heat dissipation performance is improved.

[0048] According to the embedded refrigerator of the invention, the air shielding strip 280 is disposed on the lower surface of the refrigerator body 10, the air shielding strip 280 has the flexible section 283, and the air flow suction inlet 2220 can be isolated from the air flow exhaust outlet 2230 by bending the flexible section 283, so that the circulation of the heat dissipation air flow within the small range at the bottom of the refrigerator body 10 is avoided, and the heat dissipation efficiency is increased.

[0049] Further, the air shielding strip 280 extends linearly along the front end of the compressor support plate 221 when the flexible section 283 is not bent, which is convenient to cooperate with the packaging box during transportation, thus reducing the risk of collision damage.

Claims

1. An embedded refrigerator, comprising:

a refrigerating system, comprising a compressor (20) and a condenser (30) connected to the compressor (20);

a refrigerator body (10), a compressor compartment (200) being disposed at a rear of a bottom thereof, the compressor (20) and the condenser (30) being disposed in the compressor compartment (200) at an interval in a transverse direction of the refrigerator body, a bottom wall of the compressor compartment (200) being provided with an air flow suction inlet (2220) in front of the condenser (30), and provided with an air flow exhaust outlet (2230) in front of the compressor, and the bottom wall of the compressor compartment (200) comprising a compressor support plate (221) disposed at a rear portion of the bottom wall;

a heat dissipation fan, disposed between the compressor (20) and the condenser to facilitate the formation of a heat dissipation air flow that enters from the air flow suction inlet (2220) and flows through the condenser (30) for heat exchange, and is then discharged to the air flow exhaust outlet (2230) through the compressor; and

an air shielding strip (280), disposed on a lower surface of the refrigerator body (10), the air shielding strip (280) having an air shielding state and a received state,

a middle portion of the air shielding strip (280) being a flexible section (283) that can be bent under a force, such that the air shielding strip (280) is in the air shielding state by bending the flexible section (283) and in the received state when the flexible section (283) is not bent, wherein

in the air shielding state, the air shielding strip (280) divides a space between a lower part of the

refrigerator body (10) and a ground supporting the refrigerator into an air inlet area communicated with the air flow suction inlet (2220) and an air outlet area communicated with the air flow exhaust outlet (2230); and

in the received state, the air shielding strip (280) extends linearly along a front end of the compressor support plate (221), **characterized in that** the bottom wall of the compressor compartment (200) further comprises:

an air inlet plate (222), extending forward from a front end of an area where the condenser (30) is located in the compressor support plate (221), the air flow suction inlet (2220) being formed in the air inlet plate (222); and

an air outlet plate (223), extending forward from a front end of an area where the compressor (20) is located in the compressor support plate (221), the air flow exhaust outlet (2230) being formed in the air outlet plate (223), wherein the air shielding strip (280) comprises:

a first shielding section (281), fixed between the front end of the compressor support plate (221) and the air inlet plate (222);

the flexible section (283), one end of which is connected to an end, positioned at a middle portion of the refrigerator body, of the first shielding section (281); and

a second shielding section (282), connected to the other end of the flexible section (283), disposed in an area in front of the compressor, and changing an extension direction according to a bending degree of the flexible section (283), wherein

when the air shielding strip (280) is in the air shielding state, the flexible section (283) is bent into an arc shape, and the second shielding section (282) extends obliquely forward from a position between the air inlet plate (222) and the air outlet plate (223) with an inclination direction from back to the front biased towards a side where the compressor (20) is positioned.

2. The embedded refrigerator according to claim 1, further comprising:

a partition, disposed between the air inlet plate (222) and the air outlet plate (223), used to separate an area in front of the compressor (20) and an area in front of the condenser (30) in the compressor com-

partment (200), and comprising:

a bottom plate, positioned between the air inlet plate (222) and the air outlet plate (223);
 a first side plate, extending upward from an end, close to the air outlet plate (223), of the bottom plate to isolate the area in front of the compressor; and
 a second side plate, extending upward from an end, close to the air inlet plate (222), of the bottom plate to isolate the area in front of the condenser (30), wherein
 a lower surface of the bottom plate is provided with a claw for fixing the second shielding section (282), so as to limit the position of the second shielding section (282) when the air shielding strip (280) is in the air shielding state.

3. The embedded refrigerator according to claim 2, wherein

a limit slot adapted to the shape of a front end of the heat dissipation fan is formed in a rear end wall of the first side plate for accommodating a front portion of the heat dissipation fan, and the heat dissipation fan extends from a rear portion of the first side plate to a position between the compressor (20) and the condenser (30).

4. The embedded refrigerator according to claim 2 or 3, further comprising:

an air deflector, extending from the first side plate to a front of the compressor to allow the heat dissipation air flow flowing through the compressor to flow from a side away from the first side plate to the air flow exhaust outlet, a projection of a tail end of the air deflector in a depth direction of the refrigerator body (10) being aligned with a middle portion of the compressor.

5. The embedded refrigerator according to any one of claims 1 to 4, wherein

a cross section of the air shielding strip (280) is L-shaped, wherein a horizontal side edge of the air shielding strip (280) is attached to the lower surface of the refrigerator body, a vertical side edge of the air shielding strip (280) is perpendicular to the lower surface of the refrigerator body, and the height of the vertical side edge matches the height from the lower surface of the refrigerator body (10) to the ground supporting the refrigerator.

6. The embedded refrigerator according to any one of claims 1 to 5, wherein

grilles are respectively formed at the air flow suction inlet (2220) and the air flow exhaust outlet (2230) to prevent foreign matters from entering the refrigerator

body.

7. The embedded refrigerator according to any one of claims 1 to 6, wherein
 the condenser (30) is cuboid in an overall shape, and is installed to allow its radiating fins to extend along the depth direction of the refrigerator body, so that the air entering from the air flow suction inlet (2220) flows to the compressor (20) through passages between the radiating fins.

Patentansprüche

1. Eingebauter Kühlschrank umfassend:

ein Kühlsystem, das einen Kompressor (20) und einen Kondensator (30) umfasst, der an den Kompressor (20) angeschlossen ist;
 einen Kühlschrankkörper (10), wobei ein Kompressorraum (200) an einer Rückseite eines Bodens des Kühlschrankkörpers versehen ist, wobei der Kompressor (20) und der Kondensator (30) im Kompressorraum (200) im Abstand in der Querrichtung des Kühlschrankkörpers versehen sind, wobei eine Bodenwand des Kompressorraums (200) mit einem Luftstrom-Saugeinlass (2220) vor dem Kondensator (30) und mit einem Luftstrom-Abgasauslass (2230) vor dem Kompressor versehen ist, und wobei die Bodenwand des Kompressorraums (200) eine Kompressorträgerplatte (221) umfasst, die an einem hinteren Abschnitt der Bodenwand angeordnet ist;
 einen Wärmeableitungslüfter, der zwischen dem Kompressor (20) und dem Kondensator angeordnet ist, um die Bildung eines Wärmeableitungsluftstroms zu erleichtern, der vom Luftstrom-Saugeinlass (2220) eintritt und zum Wärmeaustausch durch den Kondensator (30) fließt und dann durch den Kompressor zum Luftstrom-Abgasauslass (2230) abgeleitet wird; und
 einen Luftschirmstreifen (280), der auf einer Unterfläche des Kühlschrankkörpers (10) angeordnet ist, wobei der Luftschirmstreifen (280) einen Luftschirmzustand und einen Empfangszustand aufweist,
 wobei ein Mittelteil des Luftschirmstreifens (280) ein flexibler Abschnitt (283) ist, der unter einer Kraft verbiegen werden kann, so dass der Luftschirmstreifen (280) durch Biegen des flexiblen Abschnitts (283) im Luftschirmzustand ist und im Empfangszustand ist, wenn der flexible Abschnitt (283) nicht verbiegen ist, wobei im Luftschirmzustand der Luftschirmstreifen (280) einen Raum zwischen einem unteren Teil des Kühlschrankkörpers (10) und einem Boden,

der den Kühlschrank trägt, in einen Lufteinlassbereich, der mit dem Luftstrom-Saugeinlass (2220) kommuniziert, und einen Luftauslassbereich unterteilt, der mit dem Luftstrom-Abgasauslass (2230) kommuniziert; und wobei im Empfangszustand sich der Luftschirmstreifen (280) linear entlang eines Vorderenden der Kompressorträgerplatte (221) erstreckt, **dadurch gekennzeichnet, dass** die Bodenwand des Kompressorraums (200) ferner umfasst:

eine Lufteinlassplatte (222), die sich von einem vorderen Ende eines Bereichs nach vorne erstreckt, in dem sich der Kondensator (30) in der Kompressorträgerplatte (221) befindet, wobei der Luftstrom-Saugeinlass (2220) in der Lufteinlassplatte (222) gebildet wird; und

eine Luftauslassplatte (223), die sich von einem vorderen Ende eines Bereichs nach vorne erstreckt, in dem sich der Kompressor (20) in der Kompressorträgerplatte (221) befindet, wobei der Luftstrom-Abgasauslass (2230) in der Luftauslassplatte (223) gebildet wird, wobei der Luftschirmstreifen (280) umfasst:

einen ersten Abschirmabschnitt (281), der zwischen dem Vorderenden der Kompressorträgerplatte (221) und der Lufteinlassplatte (222) befestigt ist; den flexiblen Abschnitt (283), dessen eines Ende mit einem in einem Mittelteil des Kühlschrankkörpers angeordneten Ende des ersten Abschirmabschnitts (281) verbunden ist; und einen zweiten Abschirmabschnitt (282), der mit dem anderen Ende des flexiblen Abschnitts (283) verbunden ist, in einem Bereich vor dem Kompressor versehen ist und eine Ausdehnungsrichtung entsprechend dem Biegegrad des flexiblen Abschnitts (283) ändert,

wobei der flexible Abschnitt (283) in eine Bogenform gebogen ist, und der zweite Abschirmabschnitt (282) sich schräg nach vorne von einer Position zwischen der Lufteinlassplatte (222) und der Luftauslassplatte (223) mit einer Neigungsrichtung von hinten nach vorne erstreckt, die zu einer Seite hin geneigt ist, wo der Kompressor (20) positioniert ist, wenn sich der Luftschirmstreifen (280) im Luftschirmzustand befindet.

2. Eingebauter Kühlschrank gemäß Anspruch 1, ferner umfassend:
eine Trennwand, die zwischen der Lufteinlassplatte (222) und der Luftauslassplatte (223) versehen ist und verwendet wird, um einen Bereich vor dem Kompressor (20) und einen Bereich vor dem Kondensator (30) im Kompressorraum (200) zu trennen und Folgende umfasst:

eine Bodenplatte, die zwischen der Lufteinlassplatte (222) und der Luftauslassplatte (223) positioniert ist;

eine erste Seitenplatte, die sich von einem Ende der Bodenplatte in der Nähe der Luftauslassplatte (223) nach oben erstreckt, um den Bereich vor dem Kompressor zu isolieren; und eine zweite Seitenplatte, die sich von einem Ende der Bodenplatte in der Nähe der Lufteinlassplatte (222) nach oben erstreckt, um den Bereich vor dem Kondensator (30) zu isolieren, wobei

eine Unterfläche der Bodenplatte mit einer Klaue zum Fixieren des zweiten Abschirmabschnitts (282) versehen ist, um die Position des zweiten Abschirmabschnitts (282) zu begrenzen, wenn sich der Luftschirmstreifen (280) im Luftschirmzustand befindet.

3. Eingebauter Kühlschrank gemäß Anspruch 2, wobei

wobei in einer hinteren Endwand der ersten Seitenplatte ein an die Form eines vorderen Endes des Wärmeableitungslüfters angepasster Begrenzungsschlitz zur Aufnahme eines vorderen Abschnitts des Wärmeableitungslüfters ausgebildet ist, und der Wärmeableitungslüfter sich von einem hinteren Abschnitt der ersten Seitenplatte bis zu einer Position zwischen dem Kompressor (20) und dem Kondensator (30) erstreckt.

4. Eingebauter Kühlschrank gemäß Anspruch 2 oder 3, ferner umfassend:

einen Luftableiter, der sich von der ersten Seitenplatte bis zur Vorderseite des Kompressors erstreckt, um den durch den Kompressor fließenden Wärmeableitluftstrom von einer Seite entfernt von der ersten Seitenplatte zum Luftstrom-Abgasauslass zu ermöglichen, wobei eine Projizierung eines Endends des Luftableiters in Tiefenrichtung des Kühlschrankkörpers (10) mit einem Mittelteil des Kompressors ausgerichtet ist.

5. Eingebauter Kühlschrank gemäß einem der Ansprüche 1 bis 4, wobei

ein Querschnitt des Luftschirmstreifens (280) L-förmig ist, wobei eine horizontale Seitenkante des Luftschirmstreifens (280) an der Unterfläche des Kühl-

schrankkörpers befestigt ist, eine vertikale Seitenkante des Luftschirmstreifens (280) senkrecht zur Unterfläch e des Kühlschranks (10) bis zum Boden entspricht, der den Kühlschrank trägt.

6. Eingebauter Kühlschrank gemäß einem der Ansprüche 1 bis 5, wobei Gitter jeweils am Luftstrom-Saugeinlass (2220) und am Luftstrom-Abgasauslass (2230) ausgebildet sind, um zu verhindern, dass Fremdstoffe in den Kühlschrankkörper gelangen.
7. Eingebauter Kühlschrank gemäß einem der Ansprüche 1 bis 6, wobei der Kondensator (30) eine quaderförmige Gesamtgestalt aufweist und so installiert ist, dass seine Kühlrippen entlang der Tiefenrichtung des Kühlschranks ausdehnen können, so dass die Luft, die aus dem Luftstrom-Saugeinlass (2220) eintritt, durch Durchgänge zwischen den Kühlrippen in den Kompressor (20) fließt.

Revendications

1. Réfrigérateur encastré, comprenant :

un système de réfrigération, comprenant un compresseur (20) et un condenseur (30) connecté au compresseur (20) ;
 un corps de réfrigérateur (10), un compartiment de compresseur (200) étant disposé à l'arrière d'une partie inférieure de celui-ci, le compresseur (20) et le condenseur (30) étant disposés dans le compartiment de compresseur (200) à un intervalle dans une direction transversale du corps de réfrigérateur, une paroi inférieure du compartiment de compresseur (200) étant pourvue d'une entrée d'aspiration de flux d'air (2220) devant le condenseur (30), et pourvue d'une sortie d'évacuation de flux d'air (2230) devant le compresseur, et la paroi inférieure du compartiment de compresseur (200) comprenant une plaque de support de compresseur (221) disposée au niveau d'une partie arrière de la paroi inférieure ;
 un ventilateur de dissipation de chaleur, disposé entre le compresseur (20) et le condenseur pour faciliter la formation d'un flux d'air de dissipation thermique qui entre par l'entrée d'aspiration de flux d'air (2220) et s'écoule à travers le condenseur (30) pour un échange thermique, et est ensuite évacué vers la sortie d'évacuation de flux d'air (2230) à travers le compresseur ; et
 une bande de protection contre l'air (280), disposée sur une surface inférieure du corps de

réfrigérateur (10), la bande de protection contre l'air (280) ayant un état de protection contre l'air et un état rétracté,

une partie centrale de la bande de protection contre l'air (280) étant une section flexible (283) qui peut être pliée sous l'effet d'une force, de sorte que la bande de protection contre l'air (280) soit en l'état de protection contre l'air en pliant la section flexible (283) et en l'état rétracté lorsque la section flexible (283) n'est pas pliée, dans lequel

dans l'état de protection contre l'air, la bande de protection contre l'air (280) divise un espace entre une partie inférieure du corps de réfrigérateur (10) et un sol supportant le réfrigérateur en une zone d'entrée d'air communiquant avec l'entrée d'aspiration de flux d'air (2220) et une zone de sortie d'air communiquant avec la sortie d'évacuation de flux d'air (2230) ; et

dans l'état rétracté, la bande de protection contre l'air (280) s'étend linéairement le long d'un bord avant de la plaque de support de compresseur (221), **caractérisé en ce que** la paroi inférieure du compartiment de compresseur (200) comprend en outre :

une plaque d'entrée d'air (222), s'étendant vers l'avant depuis un bord avant d'une zone où est situé le condenseur (30) dans la plaque de support de compresseur (221), l'entrée d'aspiration de flux d'air (2220) étant formée dans la plaque d'entrée d'air (222) ; et

une plaque de sortie d'air (223), s'étendant vers l'avant depuis un bord avant d'une zone où le compresseur (20) est situé dans la plaque de support de compresseur (221), la sortie d'évacuation de flux d'air (2230) étant formée dans la plaque de sortie d'air (223), dans lequel la bande de protection contre l'air (280) comprend :

une première section de protection (281), fixée entre le bord avant de la plaque de support de compresseur (221) et la plaque d'entrée d'air (222) ; la section flexible (283), dont une extrémité est connectée à une extrémité, positionnée au niveau d'une partie centrale du corps de réfrigérateur, de la première section de protection (281) ; et

une deuxième section de protection (282), connectée à l'autre extrémité de la section flexible (283), disposée dans une zone devant le compresseur, et changeant de direction d'extension en fonction d'un degré de pliage de la

section flexible (283), dans lequel lorsque la bande de protection contre l'air (280) est en l'état de protection contre l'air, la section flexible (283) est pliée en forme d'arc, et la deuxième section de protection (282) s'étend obliquement vers l'avant depuis une position entre la plaque d'entrée d'air (222) et la plaque de sortie d'air (223) avec une direction d'inclinaison de l'arrière vers l'avant biaisée vers un côté où est situé le compresseur (20).

2. Réfrigérateur encastré selon la revendication 1, comprenant en outre :

une cloison, disposée entre la plaque d'entrée d'air (222) et la plaque de sortie d'air (223), utilisée pour séparer une zone devant le compresseur (20) et une zone devant le condenseur (30) dans le compartiment de compresseur (200), et comprenant :

une plaque inférieure, positionnée entre la plaque d'entrée d'air (222) et la plaque de sortie d'air (223) ;

une première plaque latérale, s'étendant vers le haut depuis une extrémité, proche de la plaque de sortie d'air (223), de la plaque inférieure pour isoler la zone devant le compresseur ; et

une deuxième plaque latérale, s'étendant vers le haut depuis une extrémité, proche de la plaque d'entrée d'air (222), de la plaque inférieure pour isoler la zone devant le condenseur (30), dans lequel

une surface inférieure de la plaque inférieure est pourvue d'une griffe pour fixer la deuxième section de protection (282), de manière à limiter la position de la deuxième section de protection (282) lorsque la bande de protection contre l'air (280) est en l'état de protection contre l'air.

3. Réfrigérateur encastré selon la revendication 2, dans lequel

une fente de limitation adaptée à la forme d'un bord avant du ventilateur de dissipation thermique est formée dans une paroi d'extrémité arrière de la première plaque latérale pour recevoir une partie avant du ventilateur de dissipation thermique, et

le ventilateur de dissipation thermique s'étend depuis une partie arrière de la première plaque latérale jusqu'à une position entre le compresseur (20) et le condenseur (30).

4. Réfrigérateur encastré selon la revendication 2 ou 3, comprenant en outre :

un déflecteur d'air, s'étendant depuis la première plaque latérale jusqu'à l'avant du compresseur pour

permettre au flux d'air de dissipation thermique s'écoulant à travers le compresseur de s'écouler depuis un côté éloigné de la première plaque latérale vers la sortie d'évacuation de flux d'air, une projection d'une extrémité arrière du déflecteur d'air dans une direction de profondeur du corps de réfrigérateur (10) étant alignée avec une partie centrale du compresseur.

5. Réfrigérateur encastré selon l'une quelconque des revendications 1 à 4, dans lequel

une section transversale de la bande de protection contre l'air (280) est en forme de L, dans laquelle un bord latéral horizontal de la bande de protection contre l'air (280) est attaché à la surface inférieure du corps de réfrigérateur, un bord latéral vertical de la bande de protection contre l'air (280) est perpendiculaire à la surface inférieure du corps de réfrigérateur, et la hauteur du bord latéral vertical correspond à la hauteur de la surface inférieure du corps de réfrigérateur (10) au sol supportant le réfrigérateur.

6. Réfrigérateur encastré selon l'une quelconque des revendications 1 à 5, dans lequel

des grilles sont respectivement formées au niveau de l'entrée d'aspiration de flux d'air (2220) et de la sortie d'évacuation de flux d'air (2230) pour empêcher les matières étrangères d'entrer dans le corps de réfrigérateur.

7. Réfrigérateur encastré selon l'une quelconque des revendications 1 à 6, dans lequel

le condenseur (30) est de forme globalement cuboïde, et est installé pour permettre à ses ailettes de rayonnement de s'étendre le long de la direction de profondeur du corps de réfrigérateur, de sorte que l'air entrant par l'entrée d'aspiration de flux d'air (2220) s'écoule vers le compresseur (20) à travers des passages entre les ailettes de rayonnement.

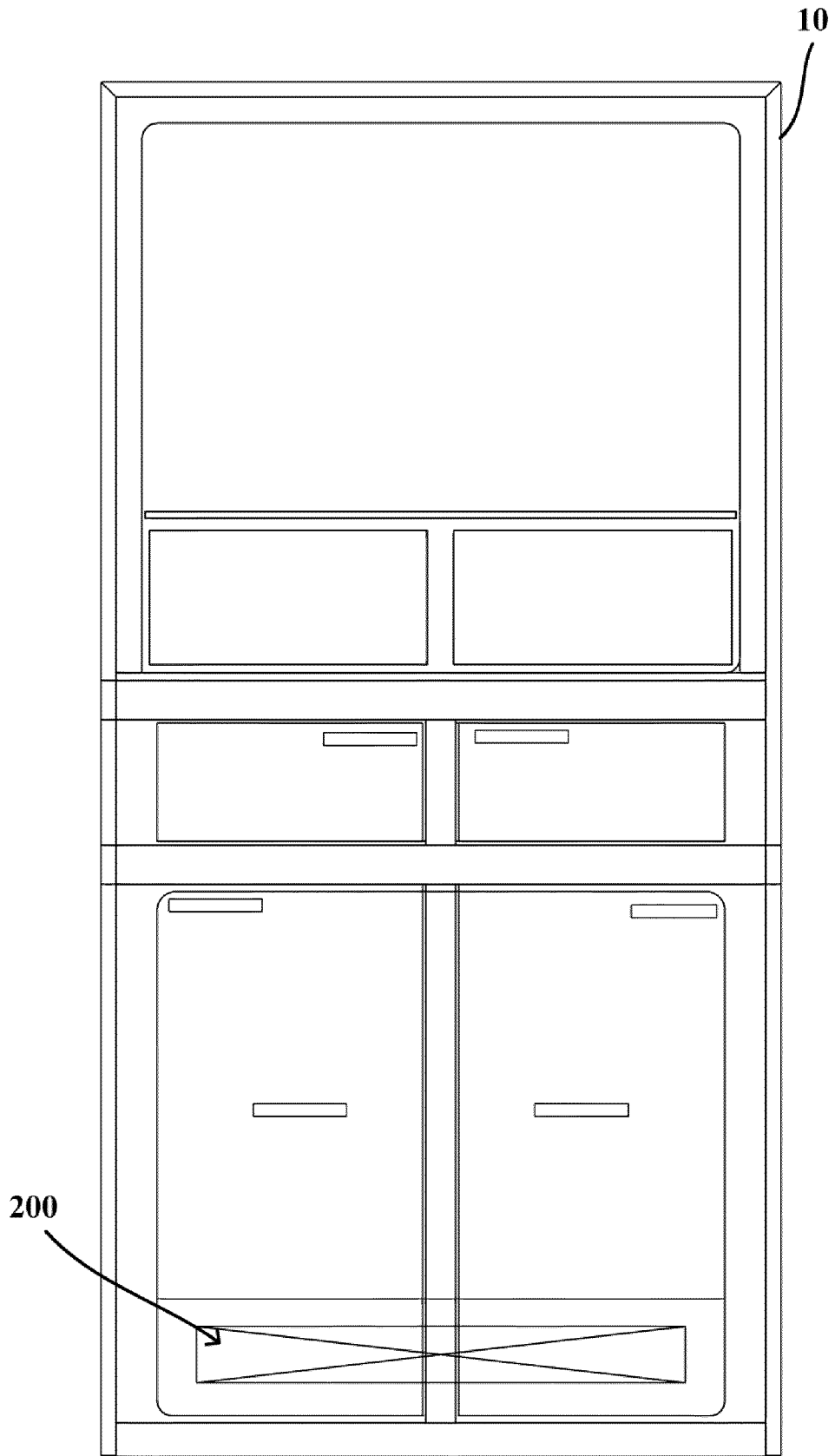

Fig. 1

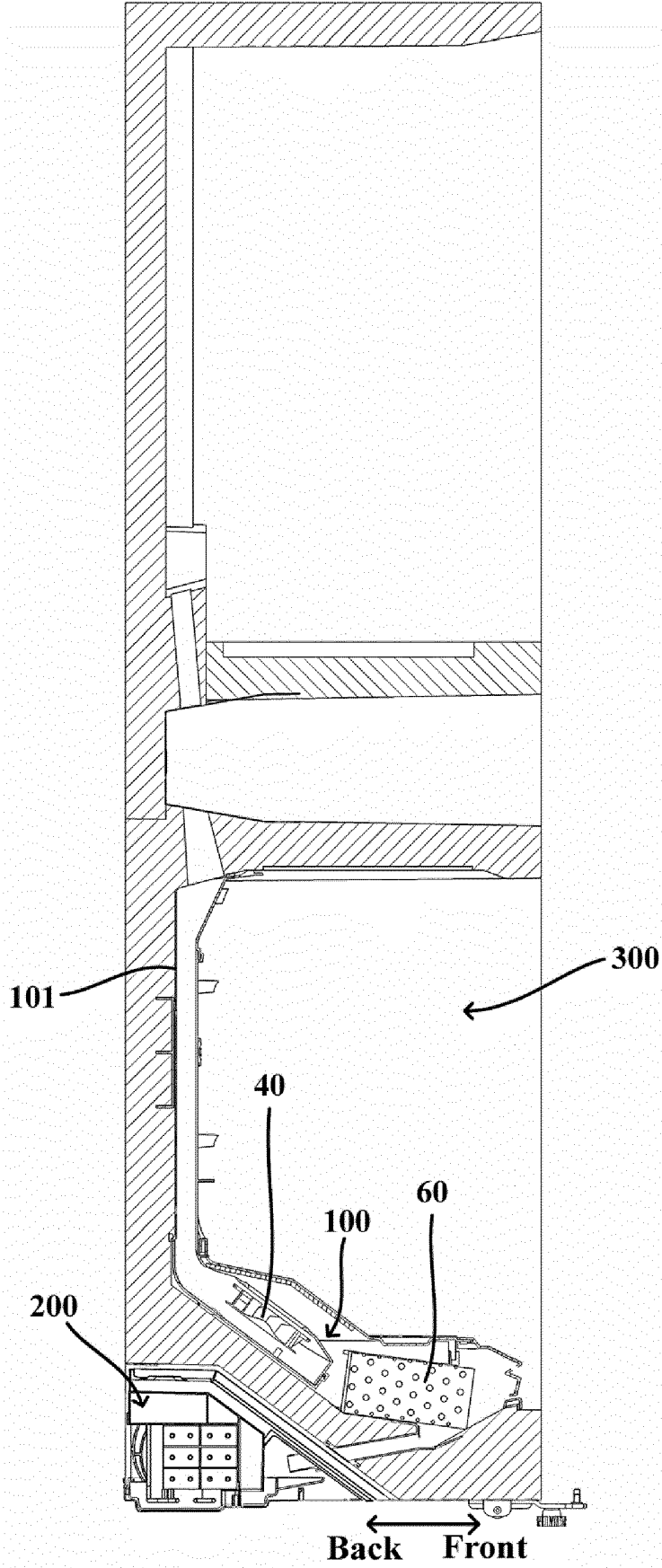

Fig. 2

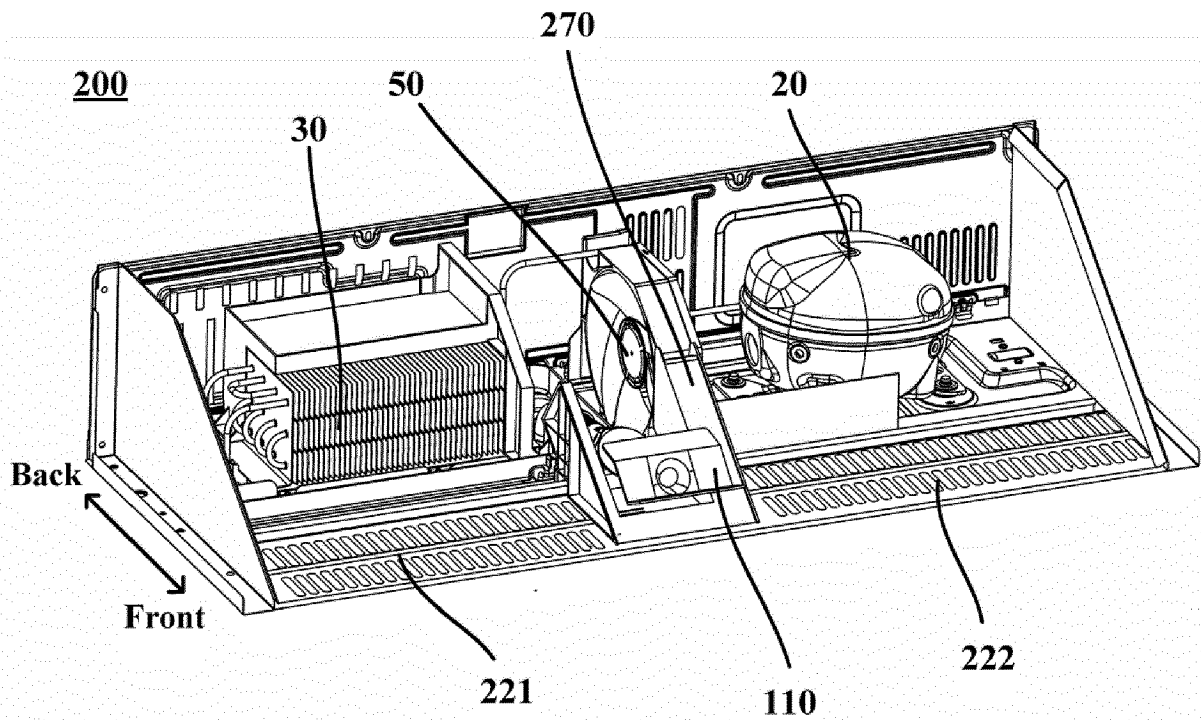

Fig. 3

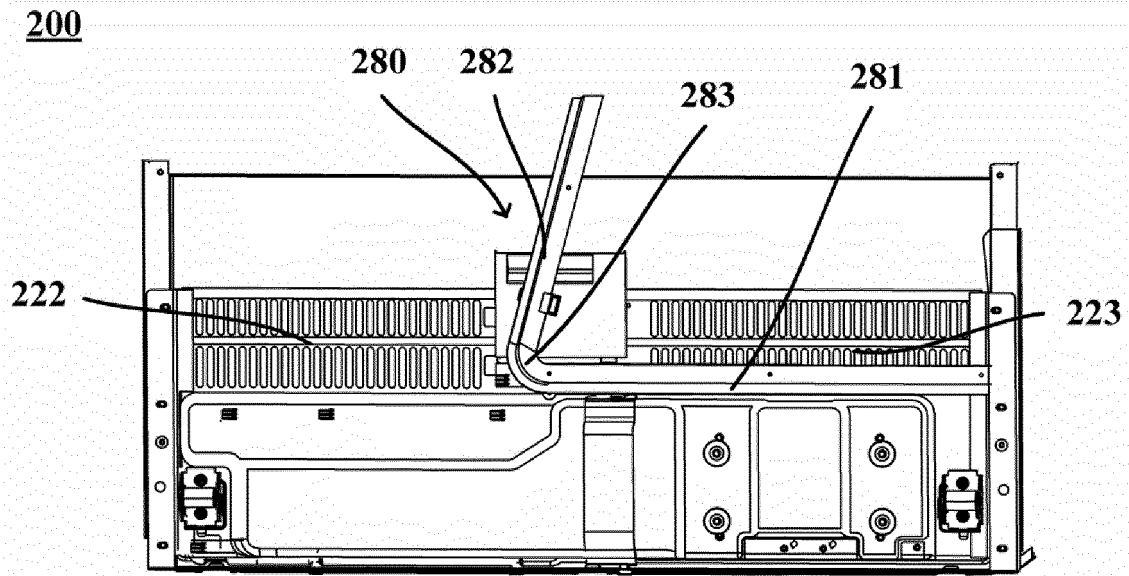

Fig. 4

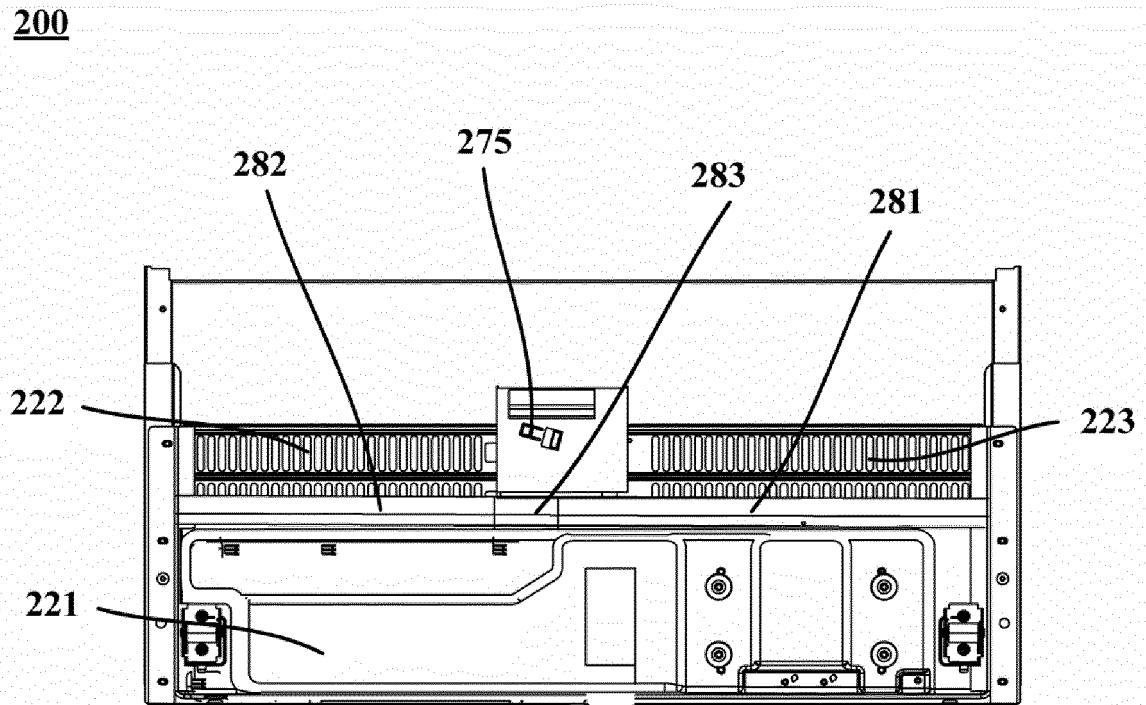

Fig. 5

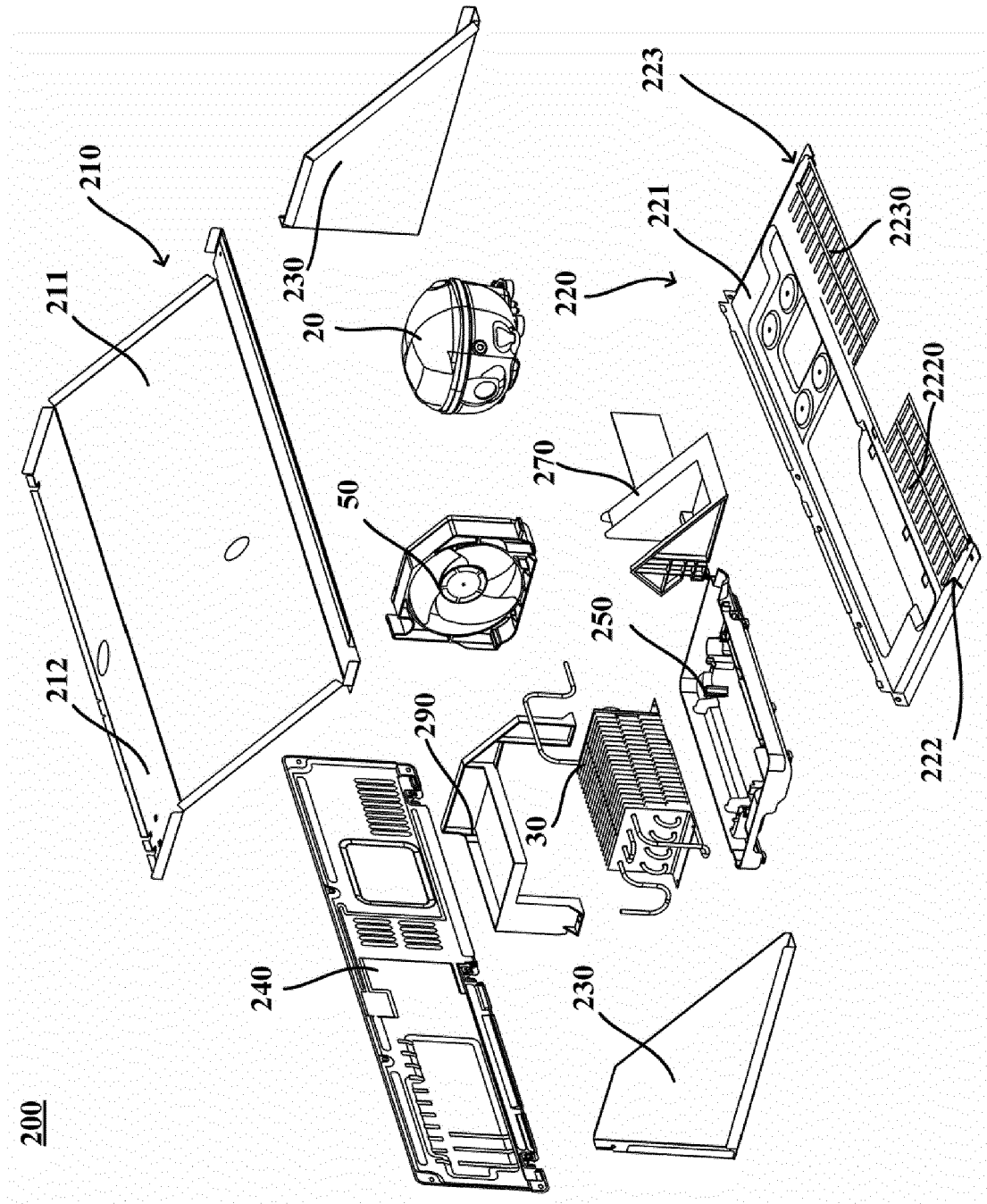

Fig. 6

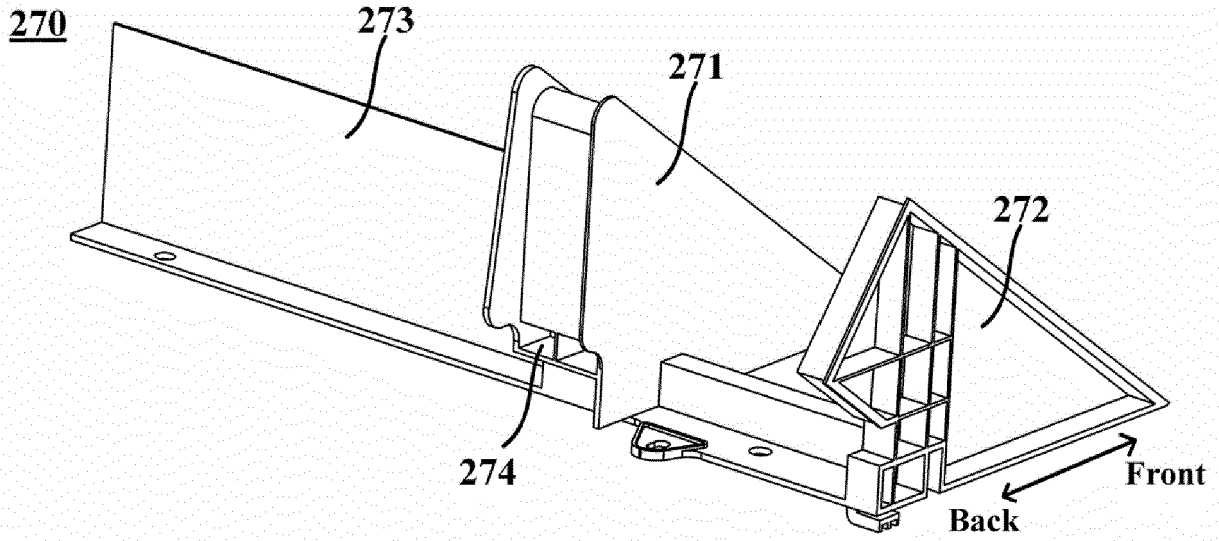

Fig. 7

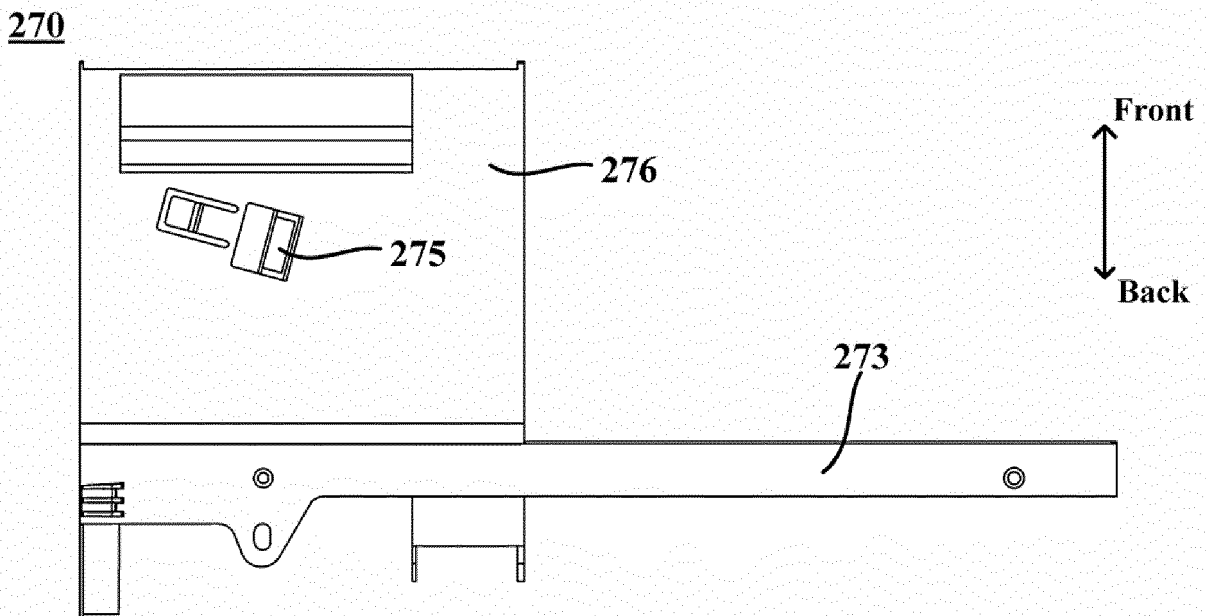

Fig. 8

REFERENCES CITED IN THE DESCRIPTION

This list of references cited by the applicant is for the reader's convenience only. It does not form part of the European patent document. Even though great care has been taken in compiling the references, errors or omissions cannot be excluded and the EPO disclaims all liability in this regard.

Patent documents cited in the description

- JP 2012202567 A [0004]
- DE 19746962 A1 [0005]
- CN 110375482 A [0006]
- CN 202511546 U [0007]
- CN 1101375506 A [0008]