



INTERNATIONAL APPLICATION PUBLISHED UNDER THE PATENT COOPERATION TREATY (PCT)

(51) International Patent Classification ⁵ : C12N 15/82, 5/10, A01H 5/00	A1	(11) International Publication Number: WO 93/21334 (43) International Publication Date: 28 October 1993 (28.10.93)
(21) International Application Number: PCT/GB93/00764 (22) International Filing Date: 13 April 1993 (13.04.93) (30) Priority data: 9208117.3 13 April 1992 (13.04.92) GB 9208954.9 24 April 1992 (24.04.92) GB (71) Applicant (for all designated States except US): ZENECA LIMITED [GB/GB]; Imperial Chemical House, 9 Millbank, London SW1P 3JF (GB). (72) Inventors; and (75) Inventors/Applicants (for US only) : CADDICK, Mark, Xavier [GB/GB]; 23 Regent Road, Crosby, Liverpool 23 (GB). GREENLAND, Andrew, James [GB/GB]; Tree Tops, Kingswood Court, Braywick Road, Maidenhead SL6 1DA (GB). RIDDELL, Kay, Victoria [GB/GB]; Lawshead Croft, Tarbrax, West Calder, West Lothian EH55 8LW (GB). SCHUCH, Wolfgang, Walter [DE/GB]; 14 Greenfinch Close, Heathlake Park, Crowthorne, Berkshire RG11 6TZ (GB). TOMSETT, Arthur, Brian [GB/GB]; 77 Upton Park Drive, Upton, Wirral, Merseyside L49 6JW (GB).		(74) Agent: HUSKISSON, Frank, Mackie; Zeneca Limited, Group Patent Services Department, P.O. Box No. 6, Bessmer Road, Welwyn Garden City, Herts AL7 1HD (GB). (81) Designated States: AU, BB, BG, BR, CA, CZ, FI, HU, JP, KP, KR, LK, MG, MN, MW, NO, NZ, PL, RO, RU, SD, SK, UA, US, European patent (AT, BE, CH, DE, DK, ES, FR, GB, GR, IE, IT, LU, MC, NL, PT, SE), OAPI patent (BF, BJ, CF, CG, CI, CM, GA, GN, ML, MR, NE, SN, TD, TG). Published <i>With international search report.</i>
(54) Title: DNA CONSTRUCTS AND PLANTS INCORPORATING THEM		
(57) Abstract <p>The invention relates to a chemically-inducible plant gene expression cassette and to plant cells transformed therewith. The expression cassette is suitable for use in any dicotyledonous or monocotyledonous plant. It comprises a first promoter operatively linked to a regulator sequence which encodes a regulator protein, and an inducible promoter operatively linked to a target gene, the inducible promoter being activated by the regulator protein in the presence of an effective exogenous inducer whereby application of the inducer causes expression of the target gene. The regulator sequence may be derived from the <i>alcR</i> gene, and the inducible promoter may be derived from the <i>alcA</i> gene promoter (both obtainable from <i>Aspergillus nidulans</i>) A chimeric promoter comprising an upstream regulatory region and a heterologous downstream transcription initiation region is also disclosed. The regulatory sequence may be derived from the <i>alcA</i> gene promoter.</p>		

FOR THE PURPOSES OF INFORMATION ONLY

Codes used to identify States party to the PCT on the front pages of pamphlets publishing international applications under the PCT.

AT	Austria	FR	France	MR	Mauritania
AU	Australia	GA	Gabon	MW	Malawi
BB	Barbados	GB	United Kingdom	NL	Netherlands
BE	Belgium	GN	Guinea	NO	Norway
BF	Burkina Faso	GR	Greece	NZ	New Zealand
BG	Bulgaria	HU	Hungary	PL	Poland
BJ	Benin	IE	Ireland	PT	Portugal
BR	Brazil	IT	Italy	RO	Romania
CA	Canada	JP	Japan	RU	Russian Federation
CF	Central African Republic	KP	Democratic People's Republic of Korea	SD	Sudan
CG	Congo	KR	Republic of Korea	SE	Sweden
CH	Switzerland	KZ	Kazakhstan	SK	Slovak Republic
CI	Côte d'Ivoire	EJ	Liechtenstein	SN	Senegal
CM	Cameroon	LK	Sri Lanka	SU	Soviet Union
CS	Czechoslovakia	LU	Luxembourg	TD	Chad
CZ	Czech Republic	MC	Monaco	TG	Togo
DE	Germany	MG	Madagascar	UA	Ukraine
DK	Denmark	ML	Mali	US	United States of America
ES	Spain	MN	Mongolia	VN	Viet Nam
FI	Finland				

DNA CONSTRUCTS AND PLANTS INCORPORATING THEM

The present invention relates to DNA constructs and plants incorporating them. In particular, it relates to expression cassettes and promoter sequences for the expression of genes in plants.

Gene expression is controlled by regions upstream (5') of the protein encoding region, commonly referred to as the "promoter". A promoter may be constitutive, tissue-specific, developmentally-programmed or inducible.

Manipulation of crop plants to improve characteristics (such as productivity or quality) requires the expression of foreign or endogenous genes in plant tissues. Such genetic manipulation therefore relies on the availability of means to control gene expression as required; for example, on the availability and use of suitable promoters which are effective in plants. It is advantageous to have the choice of a variety of different promoters so that the most suitable promoter may be selected for a particular gene, construct, cell, tissue, plant or environment. A range of promoters are known to be operative in plants.

Within the promoter region there are several domains which are necessary for full function of the promoter. The first of these domains lies immediately upstream of the structural gene and forms the "core promoter region" containing consensus sequences, normally 70 base pairs

immediately upstream of the gene. The core promoter region contains the characteristic CAAT and TATA boxes plus surrounding sequences, and represents a transcription initiation sequence which defines the transcription start point for the structural gene. The precise length of the core promoter region is indefinite but it is usually well-recognisable. Such a region is normally present, with some variation, in all promoters. The base sequences lying between the various well-characterised "boxes" appear not to be of great importance.

The presence of the core promoter region defines a sequence as being a promoter: if the region is absent, the promoter is non-functional. Furthermore, the core promoter region is insufficient to provide full promoter activity. A series of regulatory sequences upstream of the core constitute the remainder of the promoter. The regulatory sequences determine expression level, the spatial and temporal pattern of expression and, for an important subset of promoters, expression under inductive conditions.

Several naturally-occurring promoters and associated gene expression systems are known. The best characterised regulatory systems are those of bacteria in which the specific interactions between DNA-binding proteins (repressors) and the target DNA sequences (operators) results in the negative repression of gene activity.

The alcA/alcR gene activation system from the

fungus Aspergillus nidulans is also well characterised. The ethanol utilization pathway in A nidulans is responsible for the degradation of alcohols and aldehydes. Three genes have been shown to be involved in the ethanol utilization pathway. Genes alcA and alcR have been shown to lie close together on linkage group VII and aldA maps to linkage group VIII (Pateman JH et al, 1984, Proc. Soc. Lond, B217:243-264; Sealy-Lewis HM and Lockington RA, 1984, Curr. Genet, 8:253-259). Gene alcA encodes ADHI in A nidulans and aldA encodes AldDH, the second enzyme responsible for ethanol utilization. The expression of both alcA and aldA are induced by ethanol and a number of other inducers (Creaser EH et al, 1984, Biochemical J, 255:449-454) via the transcription activator alcR. The alcR gene and a co-inducer are responsible for the expression of alcA and aldA since a number of mutations and deletions in alcR result in the pleiotropic loss of ADHI and aldDH (Felenbok B et al, 1988, Gene, 73:385-396; Pateman et al, 1984; Sealy-Lewis & Lockington, 1984). The ALCR protein activates expression from alcA by binding to three specific sites in the alcA promoter (Kulmberg P et al, 1992, J. Biol. Chem, 267:21146-21153).

The alcR gene was cloned (Lockington RA et al, 1985, Gene, 33:137-149) and sequenced (Felenbok et al, 1988). The expression of the alcR gene is inducible, autoregulated and subject to glucose repression mediated by the CREA repressor (Bailey C and Arst HN, 1975, Eur. J. Biochem, 51:573-577; Lockington RA et al, 1987, Mol. Microbiology, 1:275-281; Dowzer CEA and Kelly JM, 1989, Curr.

Genet, 15:457-459; Dowzer CEA and Kelly JM, 1991, Mol. Cell. Biol, 11:5701-5709). The ALCR regulatory protein contains 6 cysteines near its N terminus coordinated in a zinc binuclear cluster (Kulmberg P et al, 1991, FEBS Letts, 280:11-16). This cluster is related to highly conserved DNA binding domains found in transcription factors of other ascomycetes. Transcription factors GAL4 and LAC9 have been shown to have binuclear complexes which have a cloverleaf type structure containing two Zn(II) atoms (Pan T and Coleman JE, 1990, Biochemistry, 29:3023-3029; Halvorsen YDC et al, 1990, J. Biol. Chem, 265:13283-13289). The structure of ALCR is similar to this type except for the presence of an asymmetrical loop of 16 residues between Cys-3 and Cys-4. ALCR positively activates expression of itself by binding to two specific sites in its promoter region (Kulmberg P et al, 1992, Molec. Cell. Biol, 12:1932-1939).

20

The regulation of the three genes, alcR, alca and aldA, involved in the ethanol utilization pathway is at the level of transcription (Lockington et al, 1987; Gwynne D et al, 1987, Gene, 51:205-216; Pickett et al, 1987, Gene, 51:217-226).

25

There are two other alcohol dehydrogenases present in A nidulans. ADHII is present in mycelia grown in non-induced media and is repressible by the presence of ethanol. ADHII is encoded by alcB and is also under the control of alcR (Sealy-Lewis & Lockington, 1984). A third alcohol dehydrogenase has also been cloned by complementation with a adh-

30

strain of S cerevisiae. This gene alcC, maps to linkage group VII but is unlinked to alcA and alcR. The gene, alcC, encodes ADHIII and utilizes ethanol extremely weakly (McKnight GL et al, 1985, EMBO J, 4:2094-2099). ADHIII has been shown to be involved in the survival of A nidulans during periods of anaerobic stress. The expression of alcC is not repressed by the presence of glucose, suggesting that it may not be under the control of alcR (Roland LJ and Stromer JN, 1986, Mol. Cell. Biol, 6:3368-3372).

In summary, A nidulans expresses the enzyme alcohol dehydrogenase I (ADH1) encoded by the gene alcA only when it is grown in the presence of various alcohols and ketones. The induction is relayed through a regulator protein encoded by the alcR gene and constitutively expressed. In the presence of inducer (alcohol or ketone), the regulator protein activates the expression of the alcA gene. The regulator protein also stimulates expression of itself in the presence of inducer. This means that high levels of the ADH1 enzyme are produced under inducing conditions (ie when alcohol or ketone are present). Conversely, the alcA gene and its product, ADH1, are not expressed in the absence of inducer. Expression of alcA and production of the enzyme is also repressed in the presence of glucose.

30

Thus the alcA gene promoter is an inducible promoter, activated by the alcR regulator protein in the presence of inducer (ie by the protein/alcohol or protein/ketone combination).

The alcR and alcA genes (including the respective promoters) have been cloned and sequenced (Lockington RA et al, 1985, Gene, 33:137-149; Felenbok B et al, 1988, Gene, 73:385-396; Gwynne et al, 1987, Gene, 51:205-216).

Alcohol dehydrogenase (adh) genes have been investigated in certain plant species. In maize and other cereals they are switched on by anaerobic conditions. The promoter region of adh genes from maize contains a 300 bp regulatory element necessary for expression under anaerobic conditions. However, no equivalent to the alcR regulator protein has been found in any plant. Hence the alcR/alcA type of gene regulator system is not known in plants. Constitutive expression of alcR in plant cells does not result in the activation of endogenous adh activity.

The knowledge of mechanisms by which gene expression is regulated in eukaryotes is much less detailed than the knowledge of bacterial systems. In yeast and mammalian cells a large number of binding sites for putative regulatory proteins have been identified in promoter sequences, and in some cases the proteins responsible have also been isolated. However, only in a few instances are the molecular details known of the protein-DNA interactions and the mechanism by which transcription is regulated. In plants, regulation of gene expression is understood at only a rudimentary level. Several regulatory elements have been identified in promoter sequences, and some regulatory proteins examined at a preliminary

level. Many such proteins have yet to be isolated and the details of the mechanisms involved have yet to be elucidated.

5 The control of expression of heterologous
genes in plant tissues is important for successful
genetic manipulation of plants to alter and/or
improve phenotypic characteristics. Promoters
and/or regulatory components from bacteria,
10 viruses, fungi and plants have been used to control
gene expression in plant cells. For example, two
well-characterised bacterial operator-repressor
systems have been used to show negative (down)
regulation of gene expression in plant cells. A
15 modified bacterial tet operator-repressor system
has been shown to repress gene expression in
electroporated plant cells. Gene expression from
the CAT gene was reduced by the placing of tet
operators in the 35S promoter (Gatz and Quail,
20 1988, Proc. Natl. Acad. Sci. USA, 85:1394-1397).
Functional tet repressor expressed from an
integrated gene also represses expression from an
integrated β -glucuronidase gene (gus) driven by
the 35S promoter containing two inserted tet
25 operators (Gatz et al, 1991, Mol. Gen. Genet,
227:229-237).

 The lac operator-repressor system has been
used to repress gene expression in tobacco cells.
30 Functional LacI protein expressed from a stably
integrated lacI gene repressed expression from a
stably integrated gus gene controlled by the maize
chlorophyll a/b binding protein (CAB) promoter
containing a lac operator. Derepression of gus

activity occurred when the cells were incubated with the inducer iso-propyl thiogalactoside (IPTG) showing that repression of gene activity is specifically due to the lacI gene product (Wilde RJ et al, 1992, EMBO J, 11:1251-1259).

As stated above, successful genetic manipulation relies on the availability of means to control gene expression as required. The scientist may use a suitable expression cassette (incorporating one or more promoters and other components) to regulate gene expression in the desired manner. The ability to enhance or reduce gene expression to achieve a desired phenotypic effect according to external circumstances is particularly advantageous. We now provide a novel plant gene expression cassette which allows external activation of target gene expression within plants.

According to a first aspect of the invention, there is provided a chemically-inducible plant gene expression cassette comprising a first promoter operatively linked to a regulator sequence which encodes a regulator protein, and an inducible promoter operatively linked to a target gene, the inducible promoter being activated by the regulator protein in the presence of an effective exogenous inducer whereby application of the inducer causes expression of the target gene.

The first promoter may be constitutive, or tissue-specific, developmentally-programmed or even inducible. The regulator sequence is preferably

the alcR gene obtainable from Aspergillus nidulans, encoding the alcR regulator protein.

5 The inducible promoter is preferably the alca gene promoter obtainable from Aspergillus nidulans, or a "chimeric" promoter derived from the regulatory sequences of the alca promoter and the core promoter region from a gene promoter which operates in plant cells (including any plant gene
10 promoter). The alca promoter or a related "chimeric" promoter is activated by the alcR regulator protein when an alcohol or ketone inducer is applied.

15 The inducible promoter may also be derived from the aldA gene promoter, the alcb gene promoter or the alcc gene promoter obtainable from Aspergillus nidulans.

20 The target gene may be an endogenous plant gene or a foreign gene, and may be a single gene or a series of genes. The target gene sequence encodes at least part of a functional protein or an antisense sequence.

25 The inducer may be any effective chemical (such as an alcohol or ketone). Suitable chemicals for use with an alca/alcr-derived cassette include those listed by Creaser et al (1984, Biochem J, 225, 449-454) such as butan-2-one (ethyl methyl
30 ketone), cyclohexanone, acetone, butan-2-ol, 3-oxobutyric acid, propan-2-ol, ethanol.

The gene expression cassette is responsive to

an applied exogenous chemical inducer enabling external activation of expression of the target gene regulated by the cassette. The expression cassette is highly regulated and suitable for
5 general use in plants.

The two parts of the expression cassette may be on the same construct or on separate constructs. The first part comprises the regulator cDNA or gene
10 sequence subcloned into an expression vector with a plant-operative promoter driving its expression. The second part comprises at least part of an inducible promoter which controls expression of a downstream target gene. In the presence of a
15 suitable inducer, the regulator protein produced by the first part of the cassette will activate the expression of the target gene by stimulating the inducible promoter in the second part of the cassette.

20

As an example of the invention, a gene expression cassette was constructed comprising the Aspergillus nidulans alcR gene under control of a constitutive promoter and an alcA:35S inducible
25 "chimeric" promoter linked to the chloramphenicol acetyl transferase (CAT) gene from E coli. Constructs representing the two parts of this expression cassette were tested in Aspergillus nidulans. For example:

30 (1) An alcR cDNA was expressed in A nidulans by placing it downstream from the CaMV 35S or nos promoter. Transformants of an alcR⁻ strain were shown to be wild type (alcR⁺) with respect to growth on ethanol as sole carbon

source, showing that the alcR construct was expressing the regulator protein.

5 (2) A construct containing a CAT gene downstream from the alcA:35S "chimeric" promoter was tested in a (alcR⁺) A nidulans strain. The CAT gene was used as the target gene because it is a suitable reporter gene for monitoring gene expression. CAT activity was alcohol-inducible (ie repressor protein plus
10 inducer were activating the "chimeric" promoter), showing that the "chimeric" promoter is functional.

15 (3) The regulator alcR construct and the alcA reporter construct were co-transformed into an alcR⁻A⁻ deletion strain. Any expression of the CAT reporter gene is induced by the alcR regulator protein produced by the regulator construct, without interference from a wild-type regulator protein. The alcA:35S
20 chimeric promoter is inducible: the promoter drives expression of the CAT reporter gene when the regulator protein and inducer are present. Thus the gene expression cassette (comprising the alcR and alcA constructs) is
25 functional and chemically-inducible (ie subject to external activation).

30 This invention is based on the construction of the above type of expression cassette and on our recognition that the functional elements of the cassette are suitable for application in other organisms, particularly in plants (such as tobacco, tomato, canola, sugarbeet, sunflower, maize, or wheat).

In practice the construct or constructs comprising the expression cassette of the invention will be inserted into a plant by transformation. Expression of target genes in the construct, being
5 under control of the chemically switchable promoter of the invention, may then be activated by the application of a chemical inducer to the plant.

Any transformation method suitable for the
10 target plant or plant cells may be employed, including infection by Agrobacterium tumefaciens containing recombinant Ti plasmids, electroporation, microinjection of cells and
15 protoplasts, microprojectile transformation and pollen tube transformation. The transformed cells may then in suitable cases be regenerated into whole plants in which the new nuclear material is
20 stably incorporated into the genome. Both transformed monocot and dicot plants may be obtained in this way.

Examples of genetically modified plants which may be produced include field crops, cereals, fruit and vegetables such as: canola, sunflower, tobacco,
25 sugarbeet, cotton, soya, maize, wheat, barley, rice, sorghum, tomatoes, mangoes, peaches, apples, pears, strawberries, bananas, melons, potatoes, carrot, lettuce, cabbage, onion.

30 The invention further provides a plant cell containing a gene expression cassette according to the invention. The gene expression cassette may be stably incorporated in the plant's genome by transformation. The invention also provides a

plant tissue or a plant comprising such cells, and plants or seeds derived therefrom.

5 The invention further provides a method for
controlling plant gene expression comprising
transforming a plant cell with a
chemically-inducible plant gene expression cassette
which has a first promoter operatively linked to a
regulator sequence which encodes a regulator
10 protein, and an inducible promoter operatively
linked to a target gene, the inducible promoter
being activated by the regulator protein in the
presence of an effective exogenous inducer whereby
application of the inducer causes expression of the
15 target gene.

As an example of the invention, we have
demonstrated the functioning of alcR/alcA
constructs in plant cells, and have shown that the
20 system is useful as an inducible plant gene
expression cassette. Regulator and reporter
constructs were transformed separately and together
into maize plant protoplasts for transient gene
expression assays. Expression of the CAT gene from
25 the alcA promoter in maize protoplasts incubated in
the presence of ethanol (inducer) is dependent on
the presence of the alcR gene (expressing the
regulator protein). Stably transformed tobacco
plants containing the alcR/alcA-CAT expression
30 cassette were also produced. High levels of
reporter (CAT) gene expression were only obtained
in the presence of the alcR regulator gene product
and following chemical induction by cyclohexanone.
High levels of activity from the alcA-CAT reporter

gene construct were not obtained under a range of growth conditions such as anaerobis, indicating that reporter gene expression was not induced by conditions that might normally be expected to induce plant alcohol dehydrogenases.

The inducible promoter forming part of the gene expression cassette according to the invention may be a "chimeric" promoter sequence, created as described above by fusing heterologous upstream and downstream regions. Such a chimeric promoter may have independent utility as an alternative plant promoter for use in genetic manipulation. Comai et al have previously described a chimeric plant promoter combining elements of the CaMV35S and the mannopine synthase (mas) promoters (1990, Plant Mol Biol, 15:373-381). In electroporated tobacco cells, the yeast GAL4 protein has been shown to stimulate CAT gene expression controlled from a 35S promoter which had GAL4 binding sites upstream from the TATA box (Ma J et al, 1988, Nature, 334:631-633).

According to a second aspect of the invention, there is provided a chimeric promoter comprising an upstream region containing a promoter regulatory sequence and a downstream region containing a transcription initiation sequence, characterised in that said upstream and downstream regions are heterologous.

The upstream region may contain a constitutive, a tissue-specific, a developmentally-programmed or an inducible promoter

regulatory sequence. There may be one or more regulatory sequences in the upstream region. The downstream region is a core promoter region. The upstream and downstream regions correspond to sequences isolated respectively from different sources. The upstream or downstream regions are fused together. The upstream and/or downstream regions may be synthesised.

The upstream sequence is preferably derived from the inducible alcA gene promoter obtainable from Aspergillus nidulans. The upstream sequence may also be derived from the aldA, alcB or alcC gene promoters obtainable from Aspergillus nidulans. The downstream sequence may be derived from the core promoter region of any plant-operative promoter (such as the CaMV35S promoter, MFS14, MFS18, GSTII-27, pMR7, Polygalacturonase promoters), or may be synthesised from consensus sequences.

The chimeric promoter may be operatively linked to one or more target gene sequences encoding at least part of a functional protein or an antisense RNA. The target gene may be any endogenous plant gene or any foreign gene.

In practice the promoter of the invention will be inserted as a promoter sequence in a recombinant gene construct destined for use in a plant. The construct will then be inserted into the plant by transformation. Any plant species may be transformed with the construct, and any suitable transformation method may be employed.

The invention further provides a plant cell containing a chimeric promoter according to the invention. The chimeric promoter may be stably incorporated in the plant's genome by transformation. The invention also provides a plant tissue or a plant comprising such cells, and plants or seeds derived therefrom.

As an example of the invention, a chimeric gene promoter sequence has been produced by fusing a regulatory region from the Aspergillus nidulans alcA gene promoter to part of the -70 core region of the Cauliflower mosaic virus (CaMV) 35S promoter (see Example 2 and Figure 3). The alcA:35S chimeric promoter sequence was linked to the chloramphenicol acetyl transferase (CAT) gene from E coli and transformed into an (alcR⁺) A nidulans strain. The CAT gene was used as a reporter gene to monitor gene expression. CAT production indicated that the chimeric promoter was functioning correctly (see Example 3).

The alcA:35S chimeric promoter is also suitable for use in any plant. Transient expression assays in maize protoplasts (Example 4) and expression from stably-incorporated genes in tobacco (Example 5) have shown that the alcA:35S promoter is fully functional in plant cells.

The invention will now be described by way of example only with reference to the accompanying drawings in which:

Figure 1 shows a scheme for the production of the 35S regulator construct.

Figure 2 shows a scheme for the production of the pNOS regulator construct.

Figure 3 shows the production of the reporter construct.

5 Figure 4 is a graph showing CAT expression from A nidulans alcA-CAT transformants.

Figure 5 is a graph showing CAT expression from an A nidulans alcA-CAT transformant against cyclohexanone concentration.

10 Figure 6 is a graph showing CAT expression from an A nidulans alcA-CAT transformant and a 35S-CAT transformant.

Figure 7 is a graph showing relative CAT expression levels in maize protoplasts.

15 Figure 8 is a graph showing relative CAT expression levels in maize protoplasts.

Figure 9 is a graph showing relative CAT expression levels in stably transformed tobacco.

20

EXAMPLE 1

PRODUCTION OF THE alcR REGULATOR CONSTRUCT.

25 The alcR genomic DNA sequence has been published, enabling isolation of a sample of alcR cDNA.

30 The alcR cDNA was cloned into two different expression vectors, pJR1(pUC) and pNOS. pJR1 contains the Cauliflower Mosaic Virus 35S promoter and pNOS contains the nos gene promoter from the Ti Plasmid of Agrobacterium tumefaciens. Both of these promoters are constitutive plant promoters

and will continually express the regulator protein. The nos polyadenylation signal is used in both the expression vectors.

5 Figure 1 illustrates the production of the
35S regulator construct by ligation of alcR cDNA
into pJR1. Partial restriction of the alcR cDNA
clone with BamHI was followed by electrophoresis in
an agarose gel and the excision and purification of
10 a 2.6 Kb fragment. The fragment was then ligated
into the pJR1 vector which had been restricted with
BamHI and phosphatased to prevent
recircularisation. The alcR gene was thus placed
under control of the CaMV 35S promoter and the nos
15 3' polyadenylation signal in this "35S-alcR"
construct.

 Figure 2 illustrates the production of the
pNOS regulator construct by ligation of alcR cDNA
20 into pNOS. Restriction of the alcR cDNA clone with
EcoRI and SalI was followed by electrophoresis and
the excision and purification of a 2.8 Kb fragment.
The pNOS vector was restricted with EcoRI and XhoI,
phosphatased and then ligated to the 2.8 Kb alcR
25 fragment. The alcR gene was thus placed under the
control of the nos gene promoter and the nos 3'
polyadenylation signal in this "nos-alcR"
construct.

EXAMPLE 2

PRODUCTION OF THE alca-CAT REPORTER CONSTRUCT CONTAINING THE CHIMERIC PROMOTER.

The plasmid pCaMVCN contains the bacterial
5 chloramphenicol transferase (CAT) reporter gene
between the 35S promoter and the nos transcription
terminator (the "35S-CAT" construct).

The alca promoter was subcloned into the
10 vector pCaMVCN to produce an "alca-CAT" construct.
Fusion of part of the alca promoter and part of the
35S promoter created a chimeric promoter which
allows expression of genes under its control.

15 Figure 3 illustrates the production of the
reporter construct. The alca promoter and the 35S
promoter have identical TATA boxes which were used
to link the two promoters together using a
recombinant PCR technique: a 246 bp region from the
20 alca promoter and the 5' end of the CAT gene from
pCaMVCN (containing part of the -70 core region of
the 35S promoter) were separately amplified and
then spliced together using PCR. The recombinant
fragment was then restriction digested with BamHI
25 and HindIII. The pCaMVCN vector was partially
digested with BamHI and HindIII, then
electrophoresed so that the correct fragment could
be isolated and ligated to the recombinant
fragment.

30

The ligation mixtures were transformed into E
coli and plated onto rich agar media. Plasmid DNA
was isolated by miniprep from the resultant
colonies and recombinant clones were recovered by

size electrophoresis and restriction mapping. The ligation junctions were sequenced to check that the correct recombinants had been recovered.

5

EXAMPLE 3

EXPRESSION IN ASPERGILLUS NIDULANS.

The completed alcR and alcA constructs were transformed into A nidulans to test their
10 functioning. Integration of the constructs into the genome is verified by Southern blotting of DNA fragments, while correct expression is shown by northern blotting to identify RNA transcripts.

15 Growth conditions

A nidulans was maintained on complete or minimal media containing 1 % agar. A nidulans mycelia was grown from conidial suspensions in supplemented minimal media with 1 % glucose as the
20 carbon source, and 10 mM ammonium tartrate as the nitrogen source for 16 hours, at 200 revs/min in an orbital incubator at 37°C. The mycelia was harvested by sieving through nylon fabric and washing with chilled distilled water. The mycelia
25 was pressed dry between sheets of absorbent paper and frozen in liquid nitrogen. The mycelia could be stored at -70°C if necessary.

Transformation of A nidulans

30 The A nidulans transformation procedure was developed from the methods of Ballance and Turner (1983) and Cambell EJ et al. (1989, Curr. Genet, 16:53-56). Plasmids were transformed into A nidulans strains by the co-transformation method. A

plasmid containing the argB gene or the N crassa
pyr4 gene was used to complement the argB2 or
pyrG89 mutation in A nidulans. Transformants were
obtained by selecting transformed protoplasts on
5 minimal media without the argB or pyr4 supplements.
By adding a five fold excess of another plasmid
with the complementing plasmid, some transformants
were obtained which also contained a genomic copy
of the other plasmid. Cellophane discs, 9 cm in
10 diameter were placed onto petri dishes of complete
medium. A conidial suspension was made up by
scraping 1 cm² of conidia from a fresh confluent A
nidulans plate and resuspending it into 3 ml of
distilled water. The conidial suspension was spread
15 onto 10 cellophane plates, 200 μ l per plate, and
incubated at 37°C for 15 hours until the spores had
germinated. The cellophane's were then transferred
to two petri dishes each containing 15 ml of
20 novozyme 234 solution, (5 mg/ml novozyme 234 in 0.8
M MgSO₄, 10 mM PO₄ buffer pH 5.8) and incubated at
30°C for 1.5-2 hours. The cellophane's were washed
in 30 ml of solution A, (0.8 M MgSO₄ in 10 mM PO₄
buffer pH 5.8) and the wash solution and the
25 novozyme solution was sieved through a glass
scintillation funnel, size 1. The protoplasts were
centrifuged at 3000 revs/min for 10 minutes and
resuspended in 6 ml of solution B, (1.2 M sorbitol,
50 mM CaCl₂, 10 mM Tris pH 7.5). The protoplasts
were centrifuged at 2500 revs/min for 5 minutes and
30 resuspended in 6 ml of solution B and then
centrifuged at 2500 revs/min for 5 minutes. The
protoplast pellet was then resuspended in 400 μ l of
solution B. 50 μ l aliquots of the protoplast
suspension were transferred into plastic bijou's

and up to 5 mg of plasmid DNA (1 mg/ml) was added. The ratio of the plasmids transformed was 5:1, (i.e., five times as much of the plasmid of interest was used compared to the transforming plasmid). 12.5 μ l of solution C, (50% PEG 4000, 50 mM CaCl₂, 10 mM Tris pH7.5), was added to each bijou of protoplasts and the suspension was gently mixed. The cells were incubated on ice for 20 minutes and then 0.5 ml of solution C was added and mixed with the cells. Immediately, 1 ml of solution B was added, and the cells were mixed with 5 ml of precooled (55°C) selection medium containing 1.2 M sorbitol and 10 mM sodium nitrate as the sole nitrogen source. An aliquot of untransformed protoplasts was added to selection medium as a control. The protoplasts were incubated at 30°C overnight then at 37°C for 2-3 days until conidiating colonies were obtained. Transformed colonies were tested for their markers on selective media before being experimented on.

Induction of *A nidulans* mycelia

Conidial suspensions of *A nidulans* were grown in supplemented minimal medium containing 0.1% fructose as the carbon source, for 20 hours at 200 revs/min in an orbital incubator at 37°C. Inducing chemical was added to the mycelia at 20 hours and allowed to grow for a further 4 hours. The mycelia was harvested as before. Uninduced mycelia was allowed to grow for 24 hours in the medium described above.

Protein extractions from *A nidulans* mycelia

300 mgs of mycelia, frozen in liquid nitrogen,

was ground in a chilled pestle and mortar with an equal amount of acid washed sand for 20 seconds. 1 ml of extraction buffer, (0.1 M Tris pH 7.5), was added and the mycelia ground for a further 30
5 seconds. Another 1 ml of extraction buffer was added and the mycelia was ground again for 30 seconds. 1 ml of the ground mycelia mixture was transferred into eppendorfs and centrifuged at 13,000 revs/min for 5 minutes in a microcentrifuge.
10 The supernatant was transferred to new eppendorfs and the protein concentration estimated using the Bradford's assay.

DNA extractions from A nidulans mycelia

15 300 mgs of mycelia was ground in a precooled pestle and mortar in liquid nitrogen until a fine powder was obtained. The mycelia was transferred to a 30 ml corex tube containing 7 ml of DNA extraction buffer and then 7 ml of phenol was added
20 and mixed. 7 ml of chloroform: iaa was added and the extraction mixture was gently mixed for 10 minutes. The mixture was centrifuged at 14,000 revs/min for 30 minutes and then the supernatant was carefully transferred into several 1.5 ml
25 eppendorf tubes. The supernatant was extracted with an equal volume of phenol, then phenol/ chloroform, then chloroform. 100 μ l of heat treated RNase, (5 mg/ml), was added and incubated at 37°C for 30 minutes. Two volumes of ethanol and 0.1 volumes of
30 3 M sodium acetate was added and mixed and incubated at room temperature for 10 minutes. The DNA was pelleted by centrifugation at 13,000 revs/min for 10 minutes in a microcentrifuge and then washed in 70% ethanol and dried at room

temperature for 30-60 minutes. The DNA was redissolved in TE or sterile distilled water at a concentration of 1 mg/ml.

5

RESULTS

(A) The regulator (alcR) constructs

10 Experiments have established that the alcR regulator constructs function in A nidulans. The constitutive promoters drive expression of the alcR gene to produce regulator protein.

15 The alcR constructs were transformed into A nidulans strain alcR125 (alcR⁻A⁺) using the above standard techniques. Strain alcR125 is a null mutant strain which carries a point mutation in alcR and cannot express the regulator protein. Expression of the alcR gene introduced on the
20 regulator construct was tested by assaying alcohol dehydrogenase I (ADH1), since the alcR gene product is known to switch on the alca gene coding for ADH1. ADH1 activity was restored in the presence of inducer, demonstrating that the introduced alcR
25 regulator construct was functional in A nidulans. The alcR gene product may also be assayed directly by Western blotting of proteins using antibodies raised against purified alcR gene product expressed in E coli. The transformed strain was back-crossed
30 to the parent strain to determine whether the regulator construct had integrated heterologously into the genome. This experiment showed that the restoration of ADH1 activity was due to the presence of the regulator construct and not

reversion of the point mutation in alcR125. As a control comparison, the alcR cDNA was transformed into A nidulans without an associated promoter.

5 Further details of these experiments are given below.

(i) The transformation of alcR125 A nidulans with the alcR cDNA regulator construct:

10

The alcR125, argB2 strain of A nidulans was co-transformed with the p35SalcR/pUC and pILJ16 plasmids using the PEG method. The p35SalcR/pUC plasmid contains the alcR cDNA between the 35S
15 promoter and the nos transcription terminator. The pILJ16 plasmid contains a genomic copy of the argB2 gene from A nidulans and can complement argB2 mutations in A nidulans.

20 Five independent A nidulans transformants were obtained which were able to grow to wild type levels on media containing ethanol as the sole source of carbon. The ability of a strain to grow on ethanol-containing media is the phenotype of a
25 functional alcR gene. The transformants varied in their ability to grow on ethanol, presumably the result of the genomic position of the alcR regulatory construct.

30 (ii) Back-crossing of the alcR+ transgenic A nidulans strains with an alcR+ wild type strain:

Two of the alcR+ transformants were back-crossed with an alcR+ wild type strain and the

progeny tested for their ability to grow on ethanol-containing media. The alcR⁺ wild type strain was also wild type for spore colour. Two hundred of the progeny obtained from the mature cleistothesium were grown on ethanol-containing media and scored for their alcR phenotype. The ratio of alcR⁺ to alcR⁻ phenotype found in the progeny was 3:1. The ratio of the green to yellow phenotype in the same two-hundred progeny was found to be 1:1.

(iii) Back-crossing of the alcR⁺ transgenic A nidulans strains with an alcR125 strain:

The above two alcR⁺ transformants were crossed with an alcR125 strain and the progeny obtained were scored for alcR phenotype. The alcR125 strain also had the panto mutation. Two hundred progeny were grown on ethanol-containing media and were found to exhibit an alcR⁺ to alcR⁻ ratio of 1:1. The ratio of the panto mutation to wild type gene was also found to be 1:1.

25 (B) The chimeric promoter

The generation of stably transformed wild type A nidulans with the alcA-CAT reporter construct established that the chimeric promoter is operative in A nidulans. Functioning of the alcA chimeric promoter introduced on the reporter construct was tested by assaying expression of the CAT gene. Initiation of CAT gene expression under inducing conditions demonstrated that the chimeric alcA:35S promoter was functioning correctly.

The alcA-CAT reporter construct was transformed into a wild type A nidulans strain (alcR⁺A⁺). The wild type strain has a normal alcR gene producing the regulator protein necessary for
5 activation of the alcA promoter in the presence of inducer.

Stably transformed A nidulans was obtained by co-transforming a pyrG89 strain with the pDJB3 and
10 palcA-CAT/pUC plasmids using the PEG method. Plasmid palcA-CAT/pUC contains the CAT reporter gene between the alcA:35S chimeric promoter and the nos transcription terminator. Two independent transformants (GA2-1 and GA2-5) were obtained which
15 contained uninterrupted copies of the alcA-CAT construct. This was shown by probing genomic DNA, restricted with HindIII, with the 0.7 kb SallI fragment of the CAT gene.

20 The CAT activity of the alcA-CAT A nidulans transformants was measured when they were grown under a variety of conditions. Figure 4 is a graph showing CAT expression from the GA2-1 and GA2-5 transformants (wild type with alcA-CAT construct)
25 growing in 0.1% fructose (F) or 1% glucose (G) in the absence or presence of 50 mM ethyl methyl ketone as inducer (I). The CAT activity of the alcA-CAT reporter construct in the transformed A nidulans strains was found to be high only when the
30 transformants were grown in 0.1% fructose and in the presence of inducer. The induction of CAT was prevented when the transformants were grown in 1% glucose even in the presence of inducer indicating the carbon catabolyte repression function of the

alcA promoter was retained. The two transformants, GA2-1 and GA2-5, exhibited different CAT induction abilities, most likely due to the differing genomic positions of the alcA-CAT reporter constructs.

5

Transformant GA2-1 was found to be over three times more inducible than transformant GA2-5 when 50 mM ethyl methyl ketone was used as the inducer. Cyclohexanone was found to induce CAT expression in the GA2-1 transformant. A concentration curve showed that cyclohexanone had an optimal inducing ability on the GA2-1 transformant when used at 25 mM. Figure 5 is a graph showing the effect of cyclohexanone concentration (mM) on CAT expression in the transformant GA2-1 growing in 0.1% fructose (F) or 1% glucose (G).

10

15

Stably transformed A nidulans was also obtained by co-transforming the pCamVCN plasmid (35S-CAT construct) with the pDJB3 plasmid into the wild type strain using the PEG method. The plasmid pDJB3 contains the pyr4 gene from N crassa, which compliments the pyrG89 mutation in A nidulans. One independent A nidulans transformant (GCMV-11) was obtained which was found to contain the 35S-CAT construct in uninterrupted form when genomic DNA, restricted with HindIII, was probed with the 0.7 kb SalI fragment of the CAT gene, in a Southern hybridisation. Digestion of the genomic DNA with XhoI and hybridisation with the 0.7 kbp SalI fragment of the CAT gene revealed multiple copies of the 35S-CAT sequence in the transformant. The function of the 35S promoter was tested by measuring the CAT expression obtained from the

20

25

30

35S-CAT A nidulans transformant. Figure 6 is a graph showing CAT expression from the GA2-5 transformant (wild type with alcA-CAT construct) and the GCMV-11 transformant (wild type with
5 35S-CAT construct) growing in 0.1% fructose (F) or 1% glucose (G) in the absence or presence of 50 mM ethyl methyl ketone as inducer (I). The expression of CAT in the 35S-CAT A nidulans transformant was found to be at a much lower level than that of the
10 alcA-CAT A nidulans transformants.

(C) The gene expression cassette

The following experiments established that the
15 gene expression cassette (comprising the alcR regulator construct and the alcA reporter construct) functions in A nidulans.

The alcA construct was transformed alone into
20 mutant A nidulans strain alc500 (alcR⁻A⁻). This mutant contains a deletion extending over both the alcR and the alcA genes: hence the reporter protein is not naturally present. There was a very low rate of CAT gene expression. Thus, the alcA
25 construct was not functional in the absence of alcR regulator protein. As a control comparison, the pCamVCN plasmid (containing the CAT gene under the control of the constitutive CaMV 35S promoter) was transformed into the A nidulans deletion strain
30 alc500.

The regulator alcR construct and the alcA reporter construct were then co-transformed into the alcR⁻A⁻ deletion strain alc500. Any expression

of the CAT reporter gene is induced by the alcR regulator protein produced by the regulator construct, without interference from a wild-type regulator protein. Transformants were grown either on fructose or glucose and subjected to inducing conditions (4 hours in the presence of ethyl methyl ketone, EMK) or non-inducing conditions (in the absence of EMK). Results of the CAT assays are shown in Table 1.

10

TABLE 1
CAT assays

EMK (INDUCER)	CARBON SOURCE	μg CAT/mg protein
YES	fructose	5.67/4.58
NO	fructose	0.12/0.08
YES	glucose	0.01/0.00
NO	glucose	0.07/0.00

The results show that the CAT reporter gene is correctly expressed under conditions which would normally induce expression of the ADH1 gene: that is, growth on fructose in the presence of inducer.

25

Growth on glucose results in poor expression of the CAT reporter gene. Glucose is known to repress ADH1 expression in wild type A nidulans strains.

30

The alcA:35S chimeric promoter is inducible. The promoter drives expression of the CAT reporter gene when the regulator protein and inducer are present. Thus the gene expression cassette
5 (comprising the alcR and alcA constructs) is functional and chemically-inducible.

Similar studies were conducted using a construct with the CaMV promoter alone fused to
10 CAT. In these experiments, low levels of CAT activity were detected following growth on glucose and were not induced by treatment with inducer.

Expression vectors lacking the alcR regulator
15 gene were also transformed into A nidulans with the alcA constructs. There was only a low level of CAT gene expression, showing that it is the regulator gene which controls the expression of the reporter gene, through the action of the regulator protein
20 on the alcA fusion promoter.

EXAMPLE 4

25 EXPRESSION IN PLANTS: TRANSIENT EXPRESSION IN MAIZE PROTOPLASTS.

The alcA-CAT and 35S-alcR constructs were introduced into maize protoplasts to determine CAT expression in transient assays after incubation in
30 the present of ethanol.

Isolation of protoplasts from maize

Maize protoplasts were prepared from a suspension culture of Black Mexican Sweet (BMS)

cells using the following method.

The cells were harvested two days after a subculture and digested in E1 enzyme solution, (2.0% cellulase RS, 0.2% pectolase Y23, 0.5M mannitol, 5mM CaCl₂.2H₂O, 0.5% MES pH5.6). 10 ml of enzyme solution was added to each gramme of tissue and incubated for 2 hours at 25°C in dim light while gently rotating. The digestion mixture was sieved sequentially through 250 µm and 38 µm sieves, rinsing with wash buffer (0.358 M KCl, 1.0 mM NH₄.NO₃, 5.0 mM CaCl₂.2H₂O, 0.5 mM KH₂PO₄ pH4.8). The protoplasts were centrifuged at 700 revs/min for 3.5 minutes and resuspended in 30 ml of wash buffer twice. The protoplasts were counted using a Fuchs-Rosenthal haemocytometer. The protoplasts were then used for transient assays.

Introduction of DNA into maize protoplasts

DNA was introduced into the protoplasts by the PEG uptake procedure. The protoplasts were resuspended at 2×10^6 /ml in MaMg medium and aliquoted out at 0.5 ml per treatment. The protoplasts were heat shocked at 45°C for 5 minutes, then allowed to cool to room temperature for 10 minutes. A standard quantity of DNA, (at 1 mg/ml), was added to the protoplast aliquots. 25 µg of the control plasmid was added to an aliquot of protoplasts; the amount of other plasmids added varied according to their size. 0.5 ml of PEG solution at 45°C was added and mixed gently with the protoplasts. The protoplasts were incubated at room temperature for 20 minutes then 5 ml of KCl solution was added, 1 ml at a time. The

protoplasts were incubated at room temperature for 10-15 minutes and then were centrifuged at 700 revs/min for 3.5 minutes. The supernatant was removed and each sample was resuspended in 1.5 ml of BMS + 9% mannitol and incubated at 25°C in the dark for 22 hours.

The maize protoplasts were transformed with the following constructs:

- 10 (a) CaMV35S promoter fused to the chloramphenicol acetyl transferase gene (35S-CAT);
- (b) alcA:35S chimeric promoter fused with the CAT gene (alcA-CAT);
- (c) 35S promoter fused to the alcR gene, plus
15 the alcA-CAT construct (alcA-CAT/35S-alcR);
- (d) 35S promoter fused to maize intron I and the alcR gene, plus the alcA-CAT construct (alcA-CAT/35S-I1-alcR).

[Intron I from the maize adhI gene has
20 previously been shown (Callis et al, 1987, Genes and Development, 1:1183-1200) to increase expression from a number of genes in maize cells].

Each plasmid combination was introduced into the
25 protoplasts in three separate aliquots.

Transient CAT expression assays

Following incubation for 22 hours in media containing 17 mM ethanol as an inducer of the alcR
30 gene product, protoplasts were harvested and proteins extracted as follows.

The protoplast samples were transferred to eppendorfs and centrifuged at 13,000 revs/min for 3

minutes. 100 μ l of 0.1 M Tris pH7.8 was added and the cells were resuspended using a micro pipette. The eppendorfs were vortexed for 30 seconds and then centrifuged again at 13,000 revs/min for 5
5 minutes. 50 μ l of the supernatant was used to measure the CAT activity and the rest to estimate the protein concentration using the Bradford's method.

10 CAT activity was measured in samples of the protein extract. CAT assays were undertaken according to the Dupont method, where a scintillation counter was used to measure transfer of [14 C] acetyl chloramphenicol from the protein
15 extract into an immiscible scintillation fluid over time.

50 μ l of protein extract was put in a plastic disposable scintillation vial, together with 200 μ l
20 of 1.25 mM chloramphenicol in 100 mM Tris pH7.8, and 0.1 μ Ci of [14 C] acetyl CoA. 5 ml of Econofluor, (950 ml/L toluene and 50 ml/L scint 7) was gently overlaid onto the reaction mixture and the vials were capped. The vials were counted
25 (cpm) sequentially in a scintillation counter for 30 seconds for a period of 1-2 hours. The cpm values of the samples were plotted against time and the gradient taken as a measure of the CAT activity of the sample. The protein concentrations of the
30 samples were measured using Bradford's method. The CAT activities of the samples were expressed as 14-[C]-acetyl chloramphenicol produced per minute per mg of protein.

RESULTS

The data from this experiment are shown in Figure 7. CAT gene expression is given as a percentage of the CAT activity observed in cells transformed with the 35S-CAT construct (production of CAT under control of a constitutive promoter). The CAT activity from the 35S-CAT construct was expressed as 100% in order to compare results from separate batches of protoplasts. The expression from untransformed protoplasts is also shown.

Cells containing the alcA-CAT construct alone showed a similar level of CAT activity as present in control cells containing no DNA (the untransformed protoplasts).

Cells containing the alcA-CAT and the regulator constructs (35S-alcR and 35S-I1-alcR) show levels of CAT expression that are 7-fold and 16-fold higher respectively than cells containing the alcA-CAT gene alone. This establishes that expression of the CAT gene from the alcA:35S promoter in maize protoplasts incubated in media containing 17 mM ethanol (as the inducer) is dependent on the presence of the alcR gene. Also there is an apparent increase in CAT expression in the presence of the 35S-I1-alcR construct, presumably due to a higher level of expression of alcR mediated by the inclusion of maize intron I. The 35S-I1-alcR construct increases CAT expression from the alcA-CAT construct from 13% to 31% of that from the 35S-CAT construct.

Further experiments with maize protoplasts have shown that the plant gene expression cassette is functioning correctly. For example, Figure 8 is a graph showing the effect of the 35S-alcR regulator construct on CAT expression from the alcA-CAT construct in the presence of 17 mM ethanol. A 35S-I1-CAT construct was used as the positive control in this experiment.

10

EXAMPLE 5

TIME COURSE OF EXPRESSION IN A STABLY TRANSFORMED TOBACCO PLANT

15

Construction of tobacco transformation vectors

Bin19 derivatives of the alcA-CAT construct and 35S-alcR/alcA-CAT construct were produced using standard procedures. Bin19 is a known plant transformation vector (Bevan, 1984, Nucleic Acids Research 12, 8711-8721).

20

The plasmid palca-CAT/BIN contains the CAT reporter gene between the alcA:35S chimeric promoter and the nos transcription terminator. It was constructed as follows: The 1.4 kbp HindIII fragment from from the alcA-CAT/pUC plasmid (containing the alcA:35S fusion promoter, the CAT gene and the nos transcription terminator) was cloned into the HindII site of the pJR11/BIN19 vector. Transformed colonies were transferred to nylon membrane and were probed with the alcA-CAT sequence. Positive colonies were shown to be correct when minipreped plasmid DNA digested with

25

30

HindIII gave a 1.4 kbp fragment.

5 The plasmid p35SalcR-alcA-CAT/BIN contains the alcR cDNA between the 35S promoter and the nos transcription terminator, and the CAT reporter gene between the alcA:35S chimeric promoter and the nos transcription terminator. It was constructed as follows: Plasmid 35S-alcR/pUC was fully digested with HindIII and partially digested with EcoRI.
10 The 3.5 kbp fragment was isolated and cloned into the pJR1i/BIN19 vector which had been restricted with EcoRI and HindIII. The 1.4 kbp HindIII fragment containing the alcA-CAT sequence from palcA-CAT/pUC was then cloned into the HindIII site
15 in the 35S-alcR/JR1i/BIN plasmid. The correct plasmid was shown to contain the 1.4 kbp HindIII fragment from the alcA-CAT sequence, and the 3.0 kbp and 0.5 kbp EcoRI fragments from the 35S-alcR sequence. A 3.5 kbp partial EcoRI/HindIII fragment
20 could be seen in the same digest. The orientation of the alcA-CAT sequence to the 35S-alcR sequence in the final plasmid is estimated to be head to tail.

25 Transformation of Agrobacterium tumefaciens

The disarmed Agrobacterium tumefaciens strain LBA4404 (pAL4404) (Hoekema et al, 1983, Nature 303, 179-180) was transformed with the above vectors using the freeze-thaw method. A single colony was
30 grown up in 40 ml of LB medium at 28°C in an orbital incubator at 200 revs/min overnight until the culture reaches an O.D.₅₈₀ of 0.5-1.0. The cells were resuspended in 1 ml of ice cold 20 mM CaCl₂ solution, and then dispensed into prechilled

eppendorfs, 100 μ l per tube. DNA was added to the cells, 0.1 μ g/100 μ l of cells, and then the cells were frozen in liquid nitrogen. The cells were then thawed at 37°C in a water bath for 5 minutes. 5 1 ml of LB medium was added to each tube and the cells were incubated at 28°C for 2-4 hours with gentle shaking to allow the bacteria to express the antibiotic resistance genes. The cells were centrifuged for 30 seconds at 13,000 revs/min in a 10 microcentrifuge and the supernatant was discarded. The cells were resuspended in 100 μ l of LB medium. The cells were spread onto LA agar plates containing 50 μ g/ml kanamycin, or other antibiotic selection afforded by the introduced plasmid. The 15 plates were incubated at 28°C for 2 days, when colonies were likely to appear.

Plasmid minipreps from *Agrobacterium tumefaciens*

Single colonies were grown in 20 ml of LB 20 medium containing antibiotic as the selective agent overnight at 28°C in an orbital incubator. The cells were centrifuged at 3000 revs/min for 5 minutes and the pellet was resuspended in 0.5 ml of miniprep solution, (5 mg/ml lysozyme in 50 mM 25 glucose, 10 mM EDTA, 25 mM Tris-HCl pH 8.0). The cells were incubated on ice for an hour, and then 1 ml of alkaline SDS (0.2 M NaOH, 1% SDS) was added. After incubation on ice for 10 minutes, 0.75 ml of 30 3 M sodium acetate was added, and the mixture was left on ice for 30 minutes. The lysis mixture was centrifuged at 15,000 revs/min for 10 minutes at 4°C, and the supernatant was transferred to 15 ml corex tubes. 5 ml of cold ethanol was added and the tubes were stored at -70°C for 30 minutes. The

tubes were then centrifuged at 15,000 revs/min for 15 minutes at 4°C and the supernatant was removed. The pellet was dissolved in 0.5 ml of T.E. and transferred to eppendorfs. The DNA solution was
5 extracted with an equal volume of phenol/chloroform three times and once with an equal volume of chloroform. The DNA was precipitated by adding 1 ml of ethanol and incubating at -70°C for 30
10 minutes. After centrifugation at 13,000 revs/min for 15 minutes in a microcentrifuge the DNA pellet was washed with 70% ethanol, dried at room temperature for a few minutes, and redissolved in 50µl T.E. 20µl of DNA solution was used per
15 restriction digest. Generally, a 2-3 fold increase in restriction enzyme and at least 4 hours digestion was required for the Agrobacterium DNA to be digested adequately.

Tobacco transformations

20 Transgenic tobacco was generated by the leaf disc method using transformed Agrobacterium tumefaciens. About 20 tissue culture grown plants were required per transformation. The plants were about 3-4 weeks old and were grown on M.S medium
25 without antibiotics. All manipulations were carried out in sterile hoods using sterile implements.

30 Leaves were cut from the tissue culture plants, placed on NBM medium in petri dishes, and incubated overnight in a plant growth room. The transformed Agrobacterium strain was grown up overnight in 100ml of LB containing kanamycin at 50 µg/ml. The next day the culture was centrifuged at

3000 revs/min for 10 minutes and resuspended in an equal volume of MS solution. 20 ml of Agrobacterium solution was placed in 9 cm petri dishes. Leaf discs were made from the leaves, using a sterile scalpel, and were put into the Agrobacterium solution in the petri dishes for 20 minutes. The leaf pieces were then transferred to the NBM plates and incubated overnight in a plant growth room. After 48 hours the leaf discs were transferred to NBM medium containing carbenicillin at 500 $\mu\text{g/ml}$ and kanamycin at 100 $\mu\text{g/ml}$ in neoplant pots. The pots were incubated in a plant growth room for 4-6 weeks. Shoots emerging from callous tissue were transferred to MS medium containing carbenicillin at 200 $\mu\text{g/ml}$ and kanamycin at 100 $\mu\text{g/ml}$ in neoplant pots, (7 to a pot). After 3 weeks, shoots that had rooted were transferred to fresh MS medium and grown on until they were about 5 cm in height. Extra cuttings were taken at this stage. The plants were then transferred to compost in 13 cm pots and sealed in polythene bags to prevent dehydration for the first few weeks.

Induction of transgenic tobacco plants

Cyclohexanone was applied to the plant leaves as a paint. The cyclohexanone paint consisted of a 10% solution of 950 g/L cyclohexanone, 35g/L syperonic NDE 1800, 16.5 g/L Tween 85 in thickener. Both surfaces of the leaf were applied with paint at 100 μl solution per 16-25 cm^2 of leaf surface, on days 0 and 2. Leaf tissue was harvested prior to inducer application and at appropriate times after the second application of paint. 1 cm^2 of leaf tissue was removed with a sterile scalpel, put

in an eppendorf, and immersed in liquid nitrogen. CAT assays were undertaken within 4 hours of leaf sampling.

5 Protein extractions from tobacco leaf tissue

The leaf tissue was allowed to defrost at room temperature for several minutes after storage in liquid nitrogen. A sterile micropestle was used to grind the leaf tissue in the eppendorf for 30
10 seconds and then 100 μ l of 100 mM Tris pH 7.8 was added. The plant mixture was then vortexed for 20 seconds and centrifuged at 13,000 revs/min for 5 minutes. The supernatant was transferred to a new eppendorf. 50 μ l of leaf extract was used for a
15 CAT assay and the rest was used to determine the protein concentration with the Bradford's method.

CAT assays

CAT assays were undertaken according to the
20 Dupont method as described in Example 4.

RESULTS

25 (A) Generation of stably transformed tobacco with the alca-CAT reporter construct

The plasmid palca-CAT/BIN was used to produce transgenic tobacco plants. Forty-four independent tobacco transformants were obtained, of which
30 twenty-three were shown to contain the alca-CAT construct when genomic DNA was amplified using PCR with the oligo's C3 and A3. Four plants were shown to contain the construct in uninterrupted form when

genomic DNA, restricted with HindIII, was probed with the 0.7 kb SalI of the CAT gene.

5 (B) Generation of stably transformed tobacco with the alca-CAT reporter and the alcr-cDNA regulator cassette

10 The plasmid p35Salcr-alca-CAT/BIN was used to produce transgenic tobacco plants. Twelve independent tobacco transformants were obtained, and analysed for the presence of the alcr regulatory and alca-CAT reporter constructs using PCR. Ten of these plants were shown to contain the alcr regulatory construct using the oligos, L4 and L6, in PCR. One of those plants, D3, was shown to
15 contain the alca-CAT reporter construct by PCR using the oligos, A3, and C3.

20 (C) Analysis of the CAT expression found in the transgenic tobacco before induction

Leaf tissue was used to measure the CAT activity of the transgenic plants. All of the alca-CAT transgenic plants were found to exhibit low CAT activity levels. The CAT expression levels varied between individual plants but none were found to
25 have higher CAT expression levels than those of the control tobacco plants. None of the alcr regulatory/alca-CAT reporter transgenic tobacco plants were found to have high CAT expression levels. The CAT activities were low and were not
30 above those of the control tobacco.

(D) The effect of cyclohexanone on the CAT activities of the plants

None of the alca-CAT transgenic plants were found to have high CAT expression levels after the application of the cyclohexanone paint to the leaves. The CAT expression levels varied between plants, but none were found to have expression levels higher than those of the control tobacco plants. Of the 35S-alcR/alca-CAT transgenic tobacco plants, one, D3, was found to exhibit a high CAT expression level after application of cyclohexanone to its leaves. The level was much higher than that found in control tobacco plants.

(E) Time course experiment following CAT activity after application of cyclohexanone

The plant known as D3 was shown by PCR to contain both the alcR regulatory and the alca-CAT reporter gene fusions (ie the entire gene expression cassette).

This experiment was a time course analysis of plant D3 compared with a plant containing only the alca-CAT construct (known as S34) and with an untransformed control (known as T1), following treatment with a formulated leaf paint containing the alcR inducer, cyclohexanone. The latter has been shown previously to be a potent inducer of ADHI expressed from the alca gene in Aspergillus cells.

The data obtained from this analysis are shown in Figure 9: at each time point, results are given in the order S34:D3:T1. Leaves were treated with

cyclohexanone leaf paint on day 0 and day 2. Samples of leaf tissue were taken immediately prior to each treatment (0-0 and 2-0 in Figure 9) and thereafter at seven intervals up until day 3.

5 Protein extracts were made from the leaf samples and CAT activity determined in the samples using the diffusion assay described above.

Following painting with cyclohexanone, CAT
10 activity increases in the leaves of plant D3 (containing the 35S-alcR/alcA-CAT genes), reaching a peak at 160 minutes after the second inductive treatment, and thereafter declines (Figure 9).

15 In contrast, treatment with cyclohexanone had no effect on the untransformed plant (T1) or the plant containing only the alcA-CAT gene (S34). In these plants, CAT activity remained at about 5-20% of the maximum activity seen in the
20 35S-alcR/alcA-CAT leaves.

This experiment established that in stably transformed plants containing the gene expression cassette 35S-alcR/alcA-CAT, high levels of
25 expression of the reporter gene (CAT) are only obtained in the presence of the alcR regulator gene product and following exogenous treatment with the inducing chemical, cyclohexanone. The inducer cyclohexanone has no effect on CAT gene expression
30 plants containing alcA-CAT alone.

(F) The effect of wounding on the CAT expression in the plants

Leaves of the plants were lacerated with a razor blade and the effect on CAT expression was measured. Samples of leaf tissue taken 240 minutes after laceration showed no increase in CAT activity in any of the plants (ie no induction of gene expression). Therefore wounding was found to have no effect on the alc expression cassette by this method.

(G) The effect of iso-propanol on the CAT expression of the plants

Iso-propanol is a weak inducer and a substrate for alcA, whereas cyclohexanone is an inducer but not a substrate (Creaser et al, 1984, Biochem J, 255:449-454). Iso-propanol has no apparent effect on the alc expression cassette.

The leaves of the plants were painted with a 10% iso-propanol solution at 0 and 60 minutes and the CAT expression of leaf samples was measured at 240 minutes. The CAT expression found in the alcA-CAT and alcA-CAT/35S-alcR transgenic plants at 0 minutes was low as it was in the control untransformed tobacco plants. After 240 minutes no significant increase in CAT activity was detected in any of the plant types.

CLAIMS

1. A chemically-inducible plant gene expression cassette comprising a first promoter operatively linked to a regulator sequence which encodes a regulator protein, and an inducible promoter operatively linked to a target gene, the inducible promoter being activated by the regulator protein in the presence of an effective exogenous inducer whereby application of the inducer causes expression of the target gene.
2. A plant gene expression cassette as claimed in claim 1 wherein the regulator sequence is derived from the alcR gene.
3. A plant gene expression cassette as claimed in claim 1 or claim 2 wherein the inducible promoter is derived from the alca gene promoter.
4. A plant gene expression cassette as claimed in claim 3 wherein the inducible promoter is a chimeric promoter.
5. A plant cell containing a gene expression cassette as claimed in claim 1.
6. A plant cell as claimed in claim 5 wherein the gene expression cassette is stably incorporated in the plant's genome.
7. A plant tissue comprising a plant cell as claimed in claim 6.

8. A plant comprising a plant cell as claimed in claim 6.
9. A plant derived from a plant as claimed in claim 8.
10. A seed derived from a plant as claimed in claim 8 or claim 9.
11. A method for controlling plant gene expression comprising transforming a plant cell with a chemically-inducible plant gene expression cassette which has a first promoter operatively linked to a regulator sequence which encodes a regulator protein, and an inducible promoter operatively linked to a target gene, the inducible promoter being activated by the regulator protein in the presence of an effective exogenous inducer whereby application of the inducer causes expression of the target gene.
12. A chimeric promoter comprising an upstream region containing a promoter regulatory sequence and a downstream region containing a transcription initiation sequence, characterised in that said upstream and downstream regions are heterologous.
13. A chimeric promoter as claimed in claim 12 wherein the regulatory sequence is derived from the alcA gene promoter.
14. A chimeric promoter as claimed in claim 12 or claim 13 wherein the transcription initiation sequence is derived from the core promoter

region of a promoter which is active in plant cells.

15. A chimeric promoter as claimed in claim 12 or claim 13 which is chemically inducible.
16. A plant cell containing a chimeric promoter as claimed in claim 12.
17. A plant cell as claimed in claim 16 wherein the chimeric promoter is stably incorporated in the plant's genome.
18. A plant tissue comprising a plant cell as claimed in claim 17.
19. A plant comprising a plant cell as claimed in claim 17.
20. A plant derived from a plant as claimed in claim 19.
21. A seed derived from a plant as claimed in claim 19 or claim 20.
22. A plant cell as claimed in claim 5 or claim 16 which is a monocotyledonous plant cell.
23. A plant cell as claimed in claims 22 which is a maize cell.
24. A plant cell as claimed in claim 5 or claim 16 which is a dicotyledonous cell.
25. A plant cell as claimed in claim 24 which is a tobacco cell.

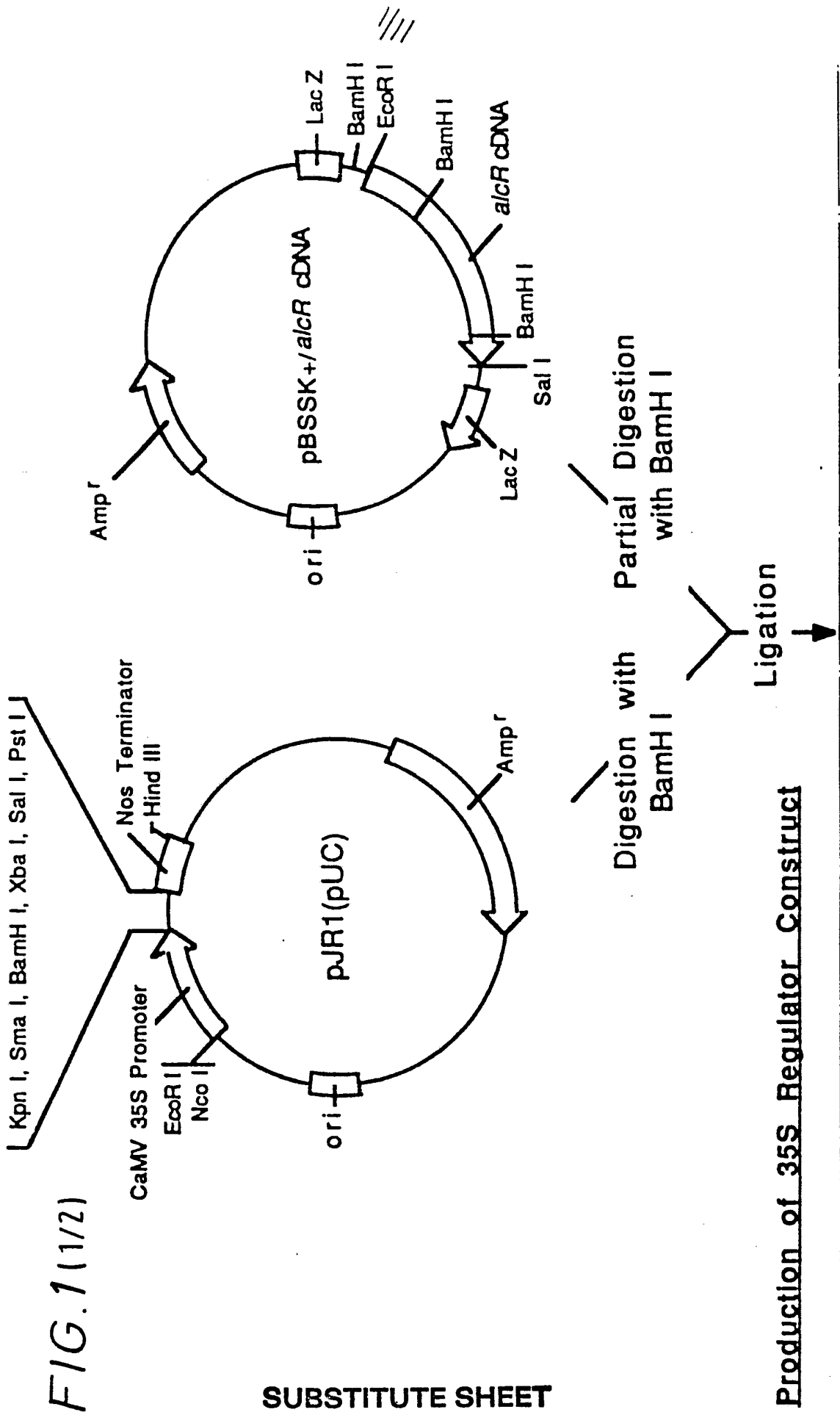

2/11

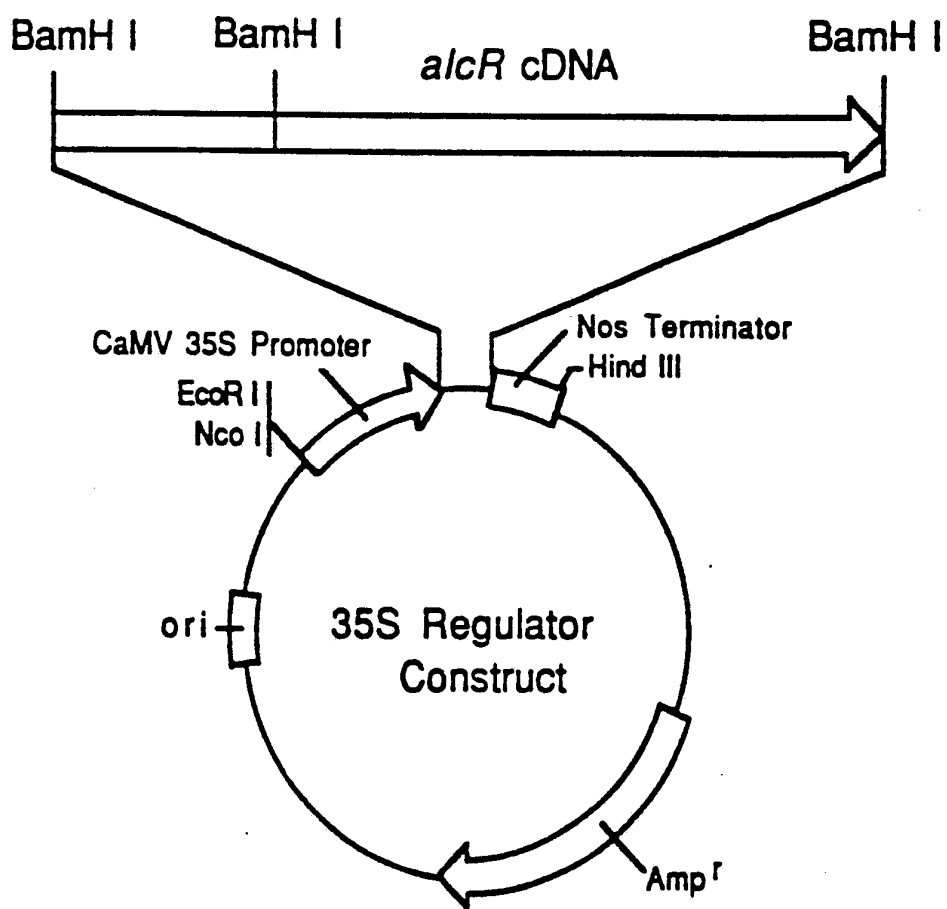
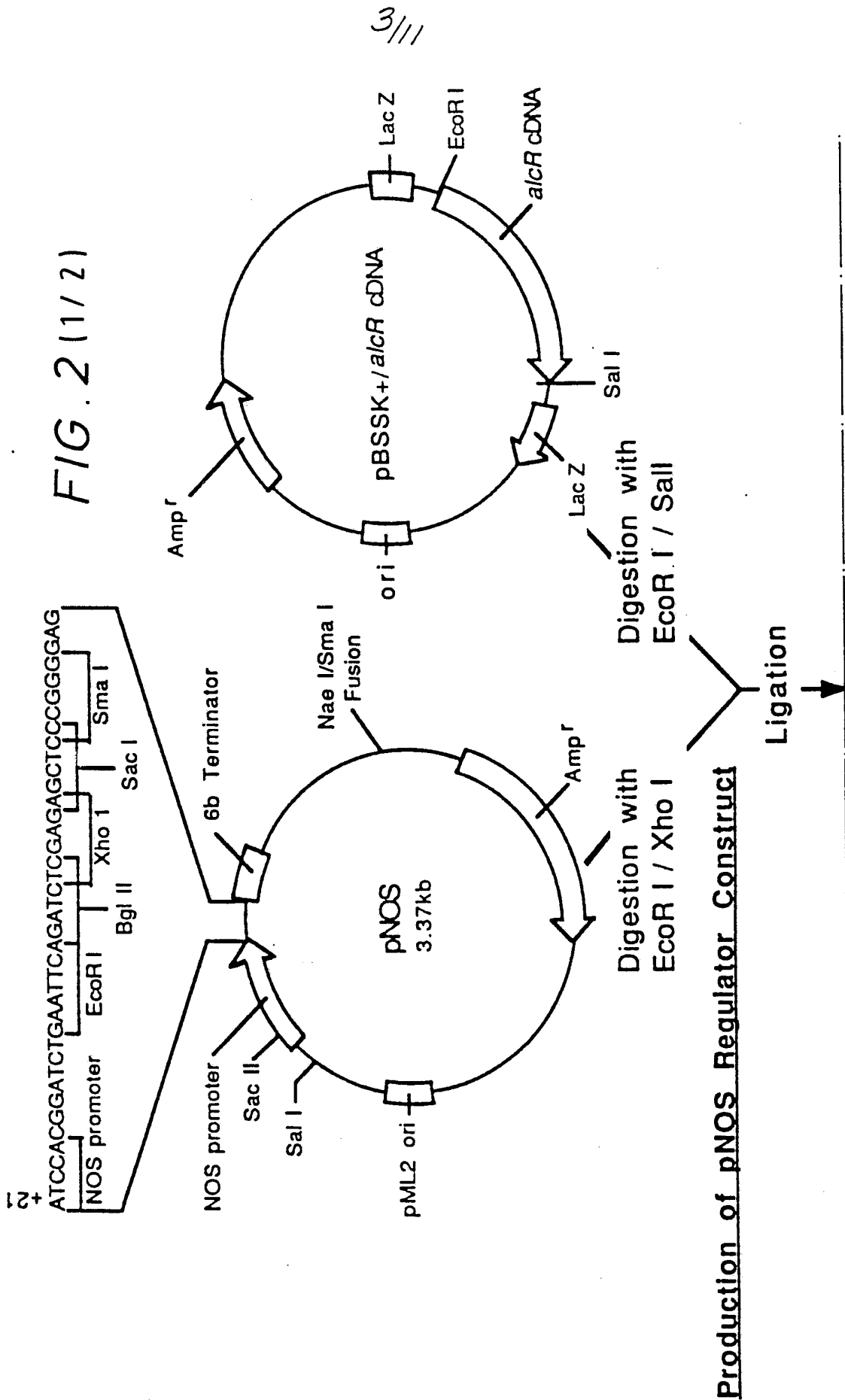

FIG. 1 (2/2)



4/11

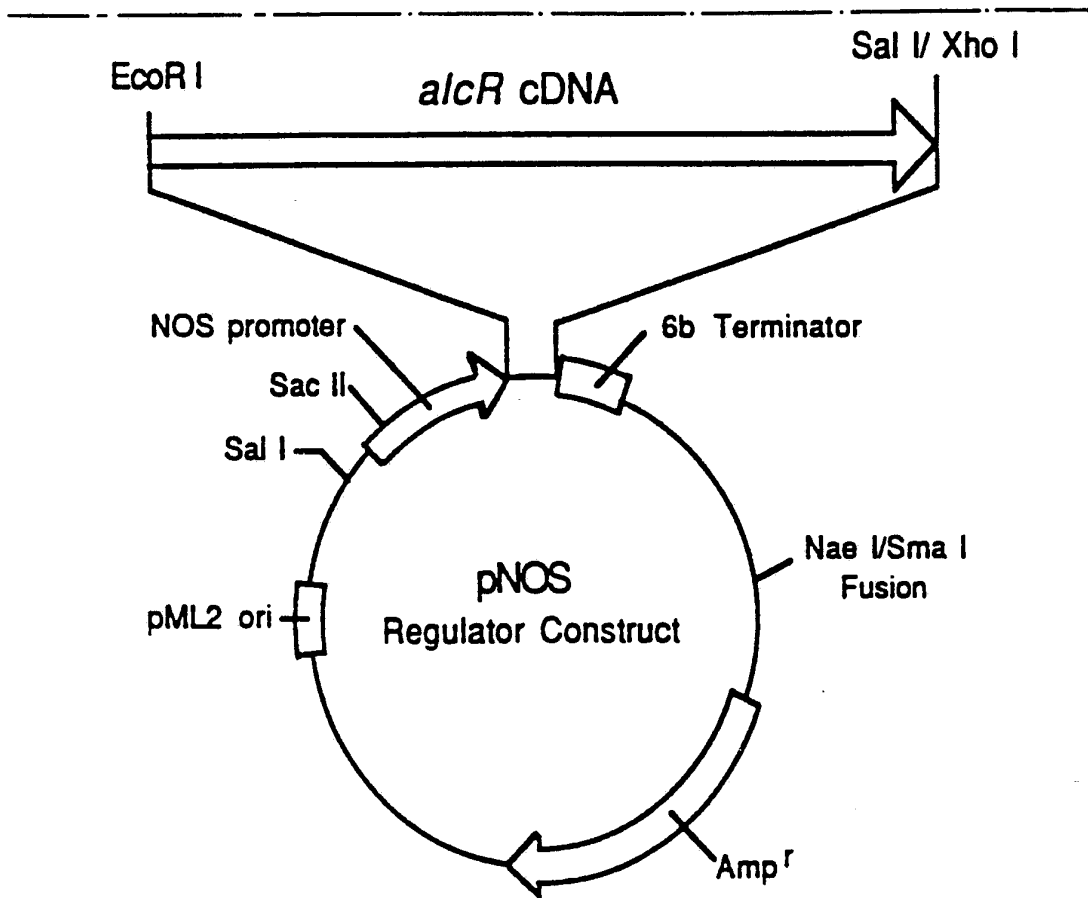
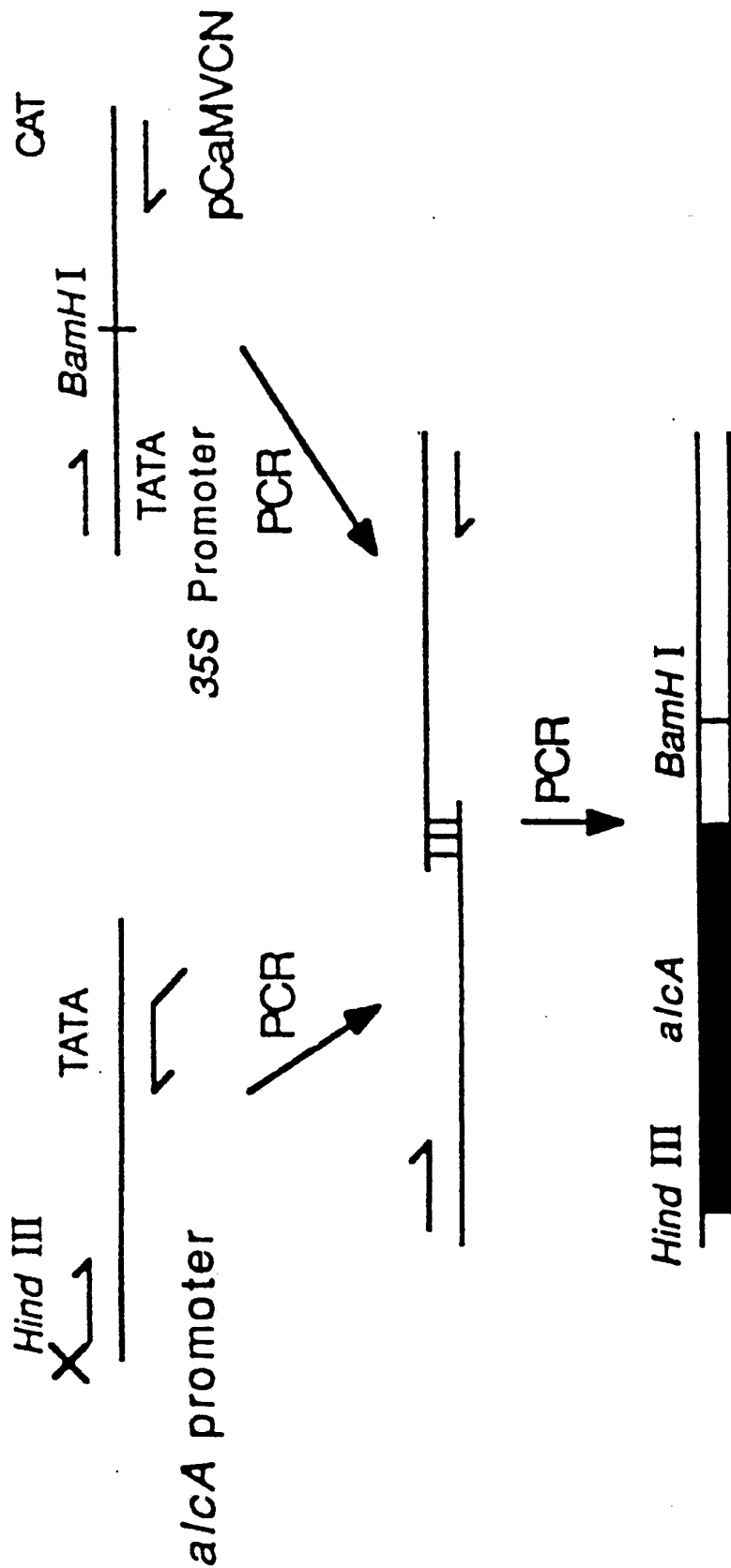
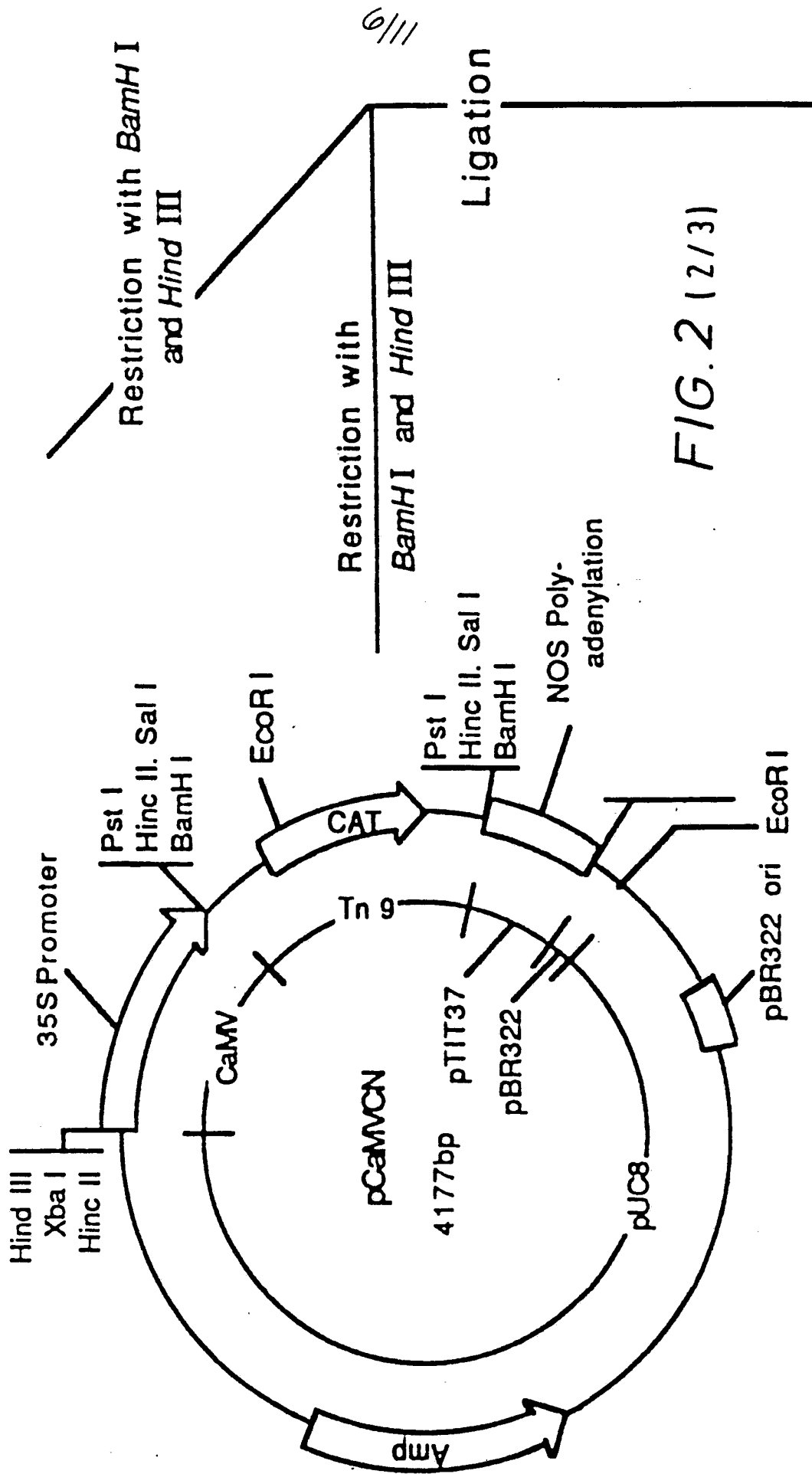

FIG. 2 (2/2)

FIG. 3 (1/3)
Production of Reporter Construct





7/11

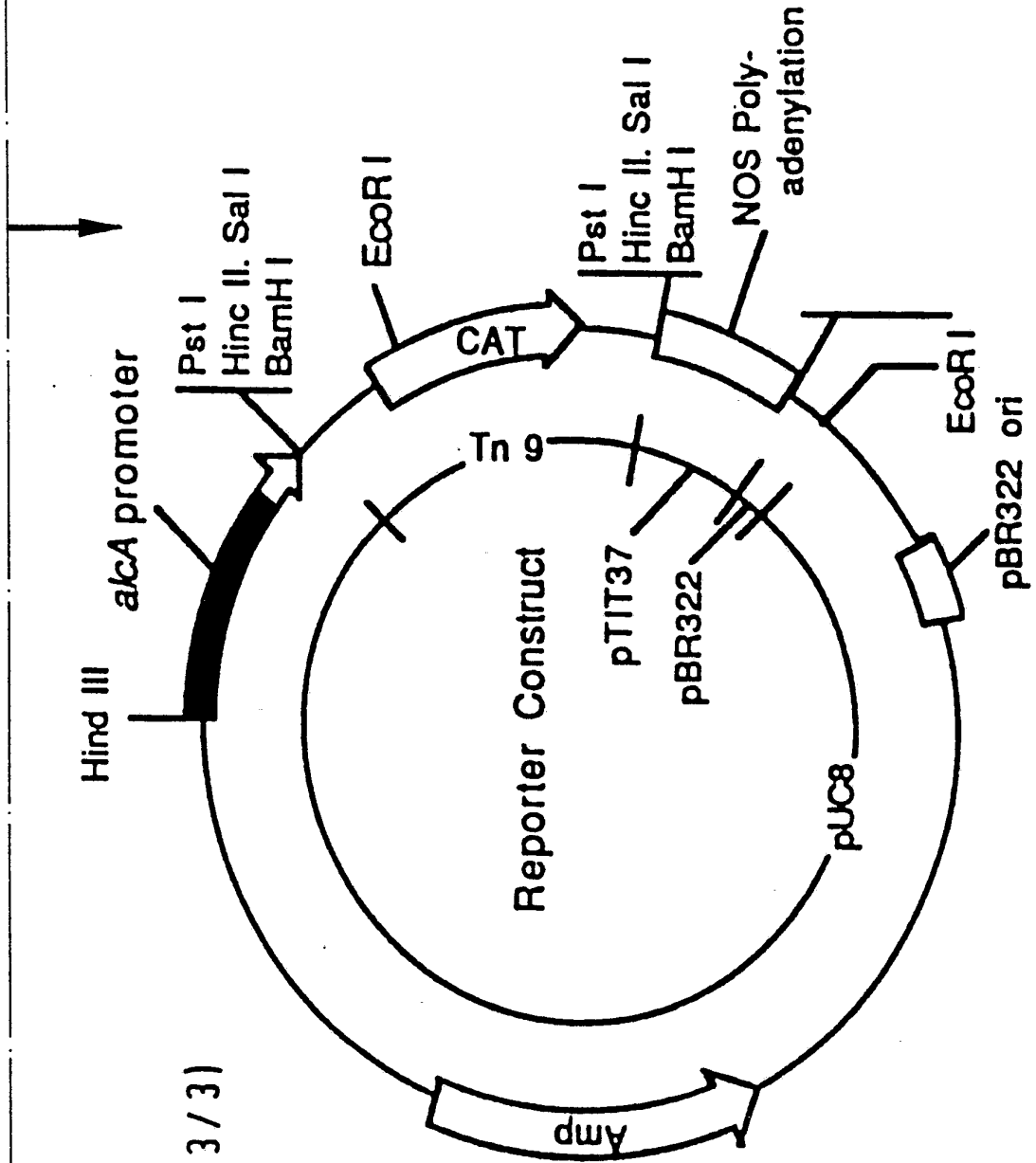
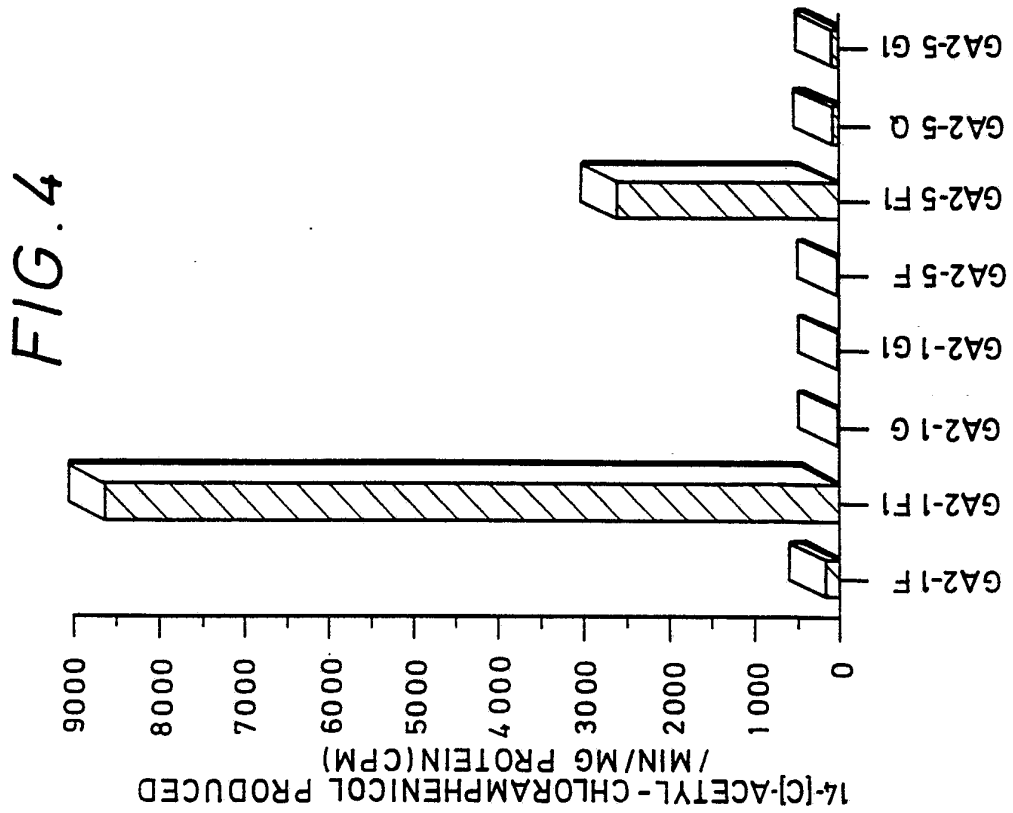
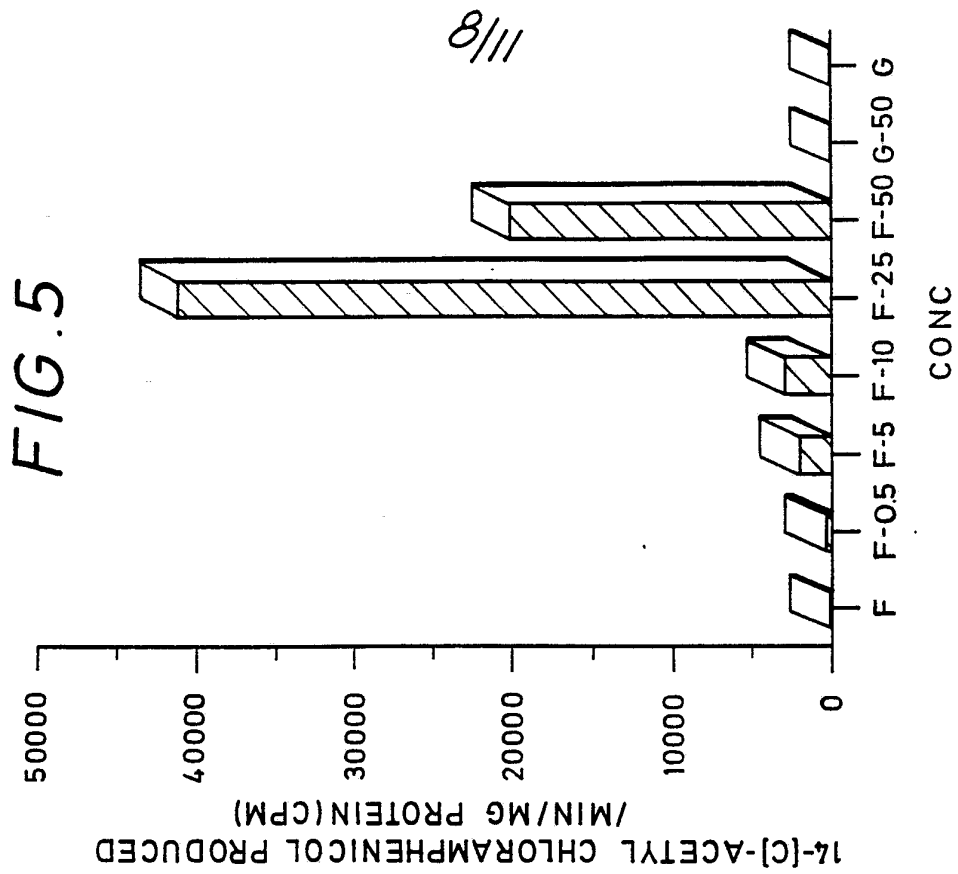

FIG. 3(3/3)



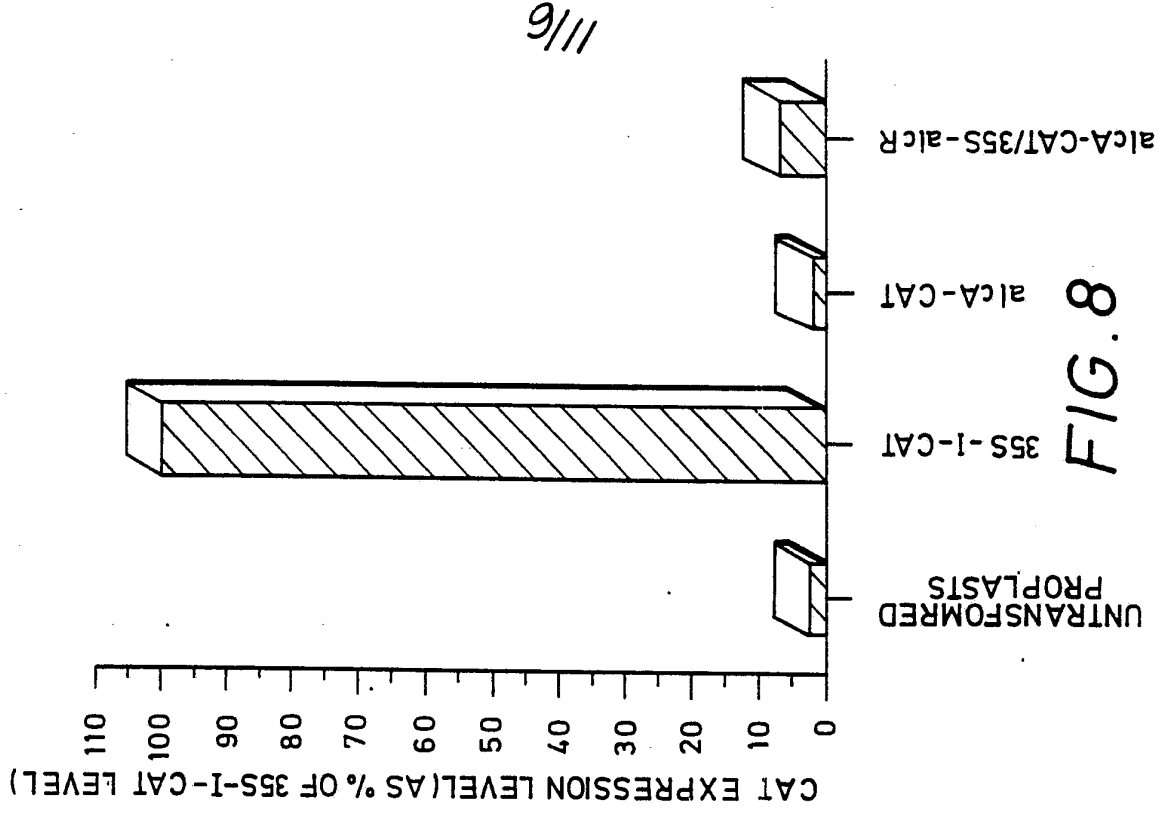

FIG. 8

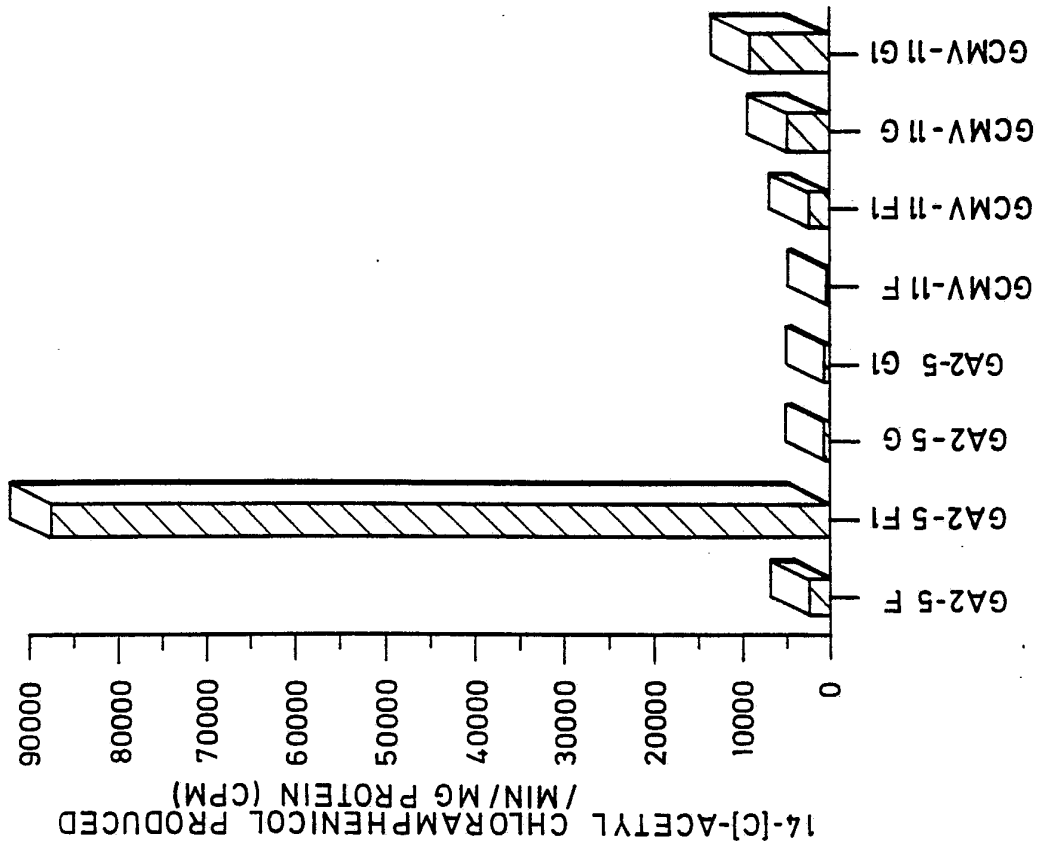
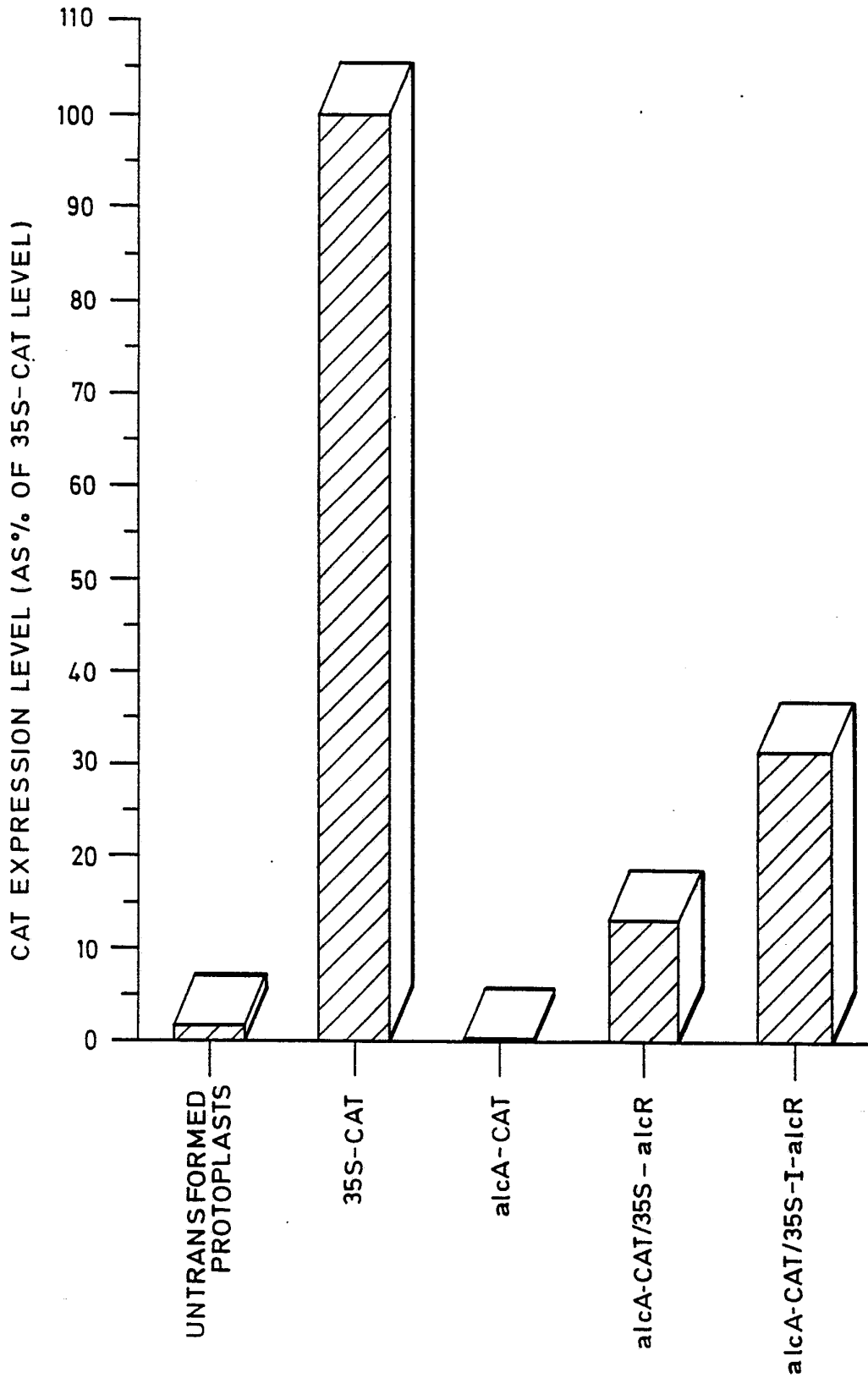

FIG. 6

10/11

FIG. 7



SUBSTITUTE SHEET

//////
FIG. 9

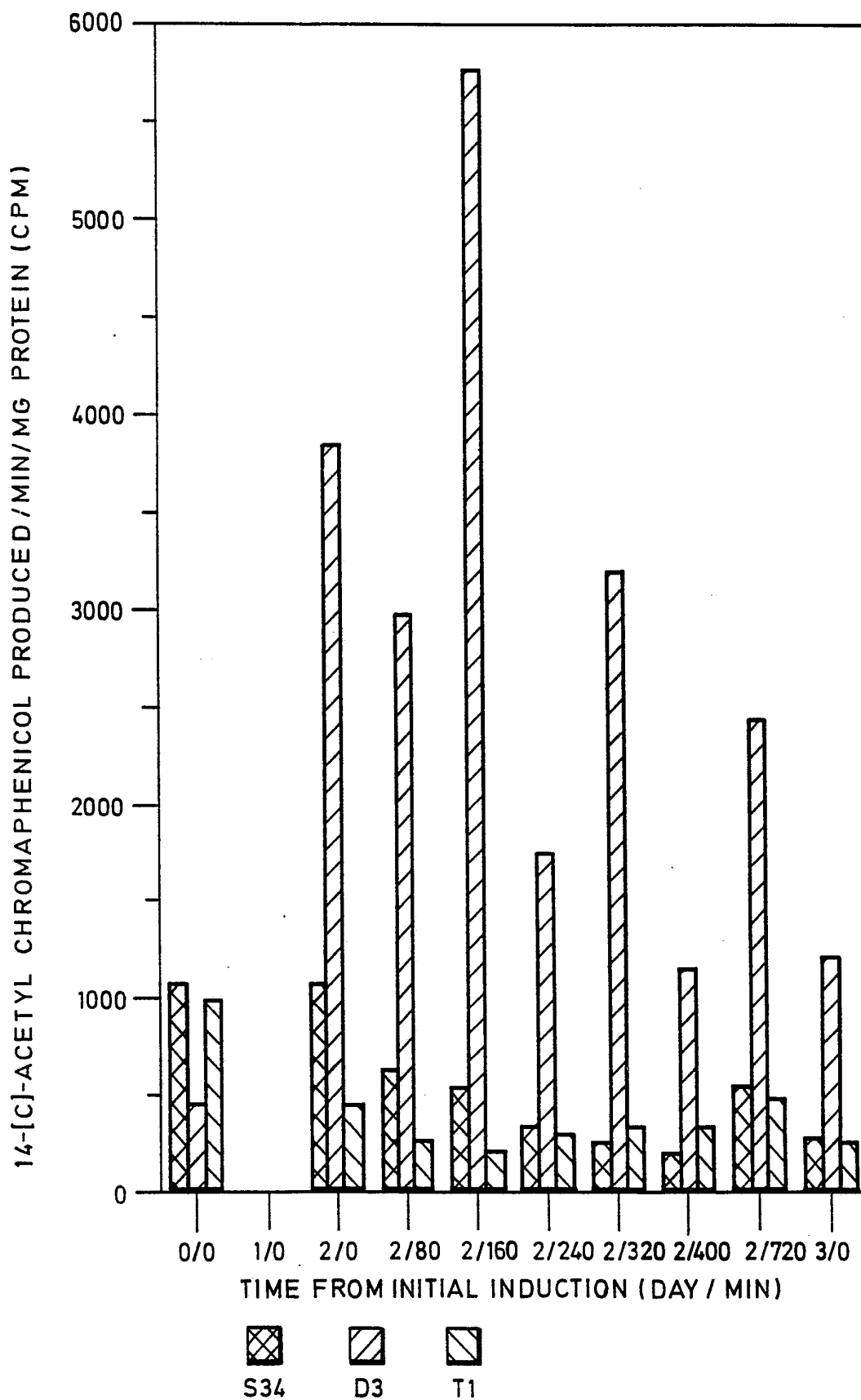

INTERNATIONAL SEARCH REPORT

International Application No

PCT/GB 93/00764

I. CLASSIFICATION OF SUBJECT MATTER (if several classification symbols apply, indicate all) ⁶		
According to International Patent Classification (IPC) or to both National Classification and IPC		
Int.Cl. 5 C12N15/82; C12N5/10; A01H5/00		
II. FIELDS SEARCHED		
Minimum Documentation Searched ⁷		
Classification System	Classification Symbols	
Int.Cl. 5	C12N ; A01H	
Documentation Searched other than Minimum Documentation to the Extent that such Documents are Included in the Fields Searched ⁸		
III. DOCUMENTS CONSIDERED TO BE RELEVANT⁹		
Category ¹⁰	Citation of Document, ¹¹ with indication, where appropriate, of the relevant passages ¹²	Relevant to Claim No. ¹³
X	PROCEEDINGS OF THE NATIONAL ACADEMY OF SCIENCES OF USA vol. 88, December 1991, WASHINGTON US pages 10421 - 10425 SCHENA, M., ET AL. 'A steroid-inducible gene expression system for plants' see the whole document ---	1,5-9, 11,12, 15,16, 18-20, 24,25
X	THE PLANT CELL. vol. 2, no. 4, April 1990, ROCKVILLE, MD, USA. pages 357 - 366 VAN DE RHEE, M.D., ET AL. 'Analysis of regulatory elements involved in the induction of two tobacco genes by salicylate treatment and virus infection' see page 360, left column ---	12,14-21
	-/--	
<p>¹⁰ Special categories of cited documents:</p> <p>"A" document defining the general state of the art which is not considered to be of particular relevance</p> <p>"E" earlier document but published on or after the international filing date</p> <p>"L" document which may throw doubts on priority claim(s) or which is cited to establish the publication date of another citation or other special reason (as specified)</p> <p>"O" document referring to an oral disclosure, use, exhibition or other means</p> <p>"P" document published prior to the international filing date but later than the priority date claimed</p> <p>"T" later document published after the international filing date or priority date and not in conflict with the application but cited to understand the principle or theory underlying the invention</p> <p>"X" document of particular relevance; the claimed invention cannot be considered novel or cannot be considered to involve an inventive step</p> <p>"Y" document of particular relevance; the claimed invention cannot be considered to involve an inventive step when the document is combined with one or more other such documents, such combination being obvious to a person skilled in the art.</p> <p>"&" document member of the same patent family</p>		
IV. CERTIFICATION		
Date of the Actual Completion of the International Search	Date of Mailing of this International Search Report	
14 JULY 1993	30. 07. 93	
International Searching Authority	Signature of Authorized Officer	
EUROPEAN PATENT OFFICE	MADDOX A.D.	

III. DOCUMENTS CONSIDERED TO BE RELEVANT (CONTINUED FROM THE SECOND SHEET)		
Category ^o	Citation of Document, with indication, where appropriate, of the relevant passages	Relevant to Claim No.
X	PLANT MOLECULAR BIOLOGY. vol. 15, 1990, DORDRECHT, THE NETHERLANDS. pages 593 - 604 OLIVE, M.R., ET AL. 'Functional properties of the anaerobic responsive element of the maize Adh 1 gene' see the whole document ----	12,22,23
X	PLANT MOLECULAR BIOLOGY. vol. 17, 1991, DORDRECHT, THE NETHERLANDS. pages 985 - 993 VILARDELL, J., ET AL. 'Regulation of the maize rab17 gene promoter in transgenic heterologous systems' see the whole document ----	22
A	NATURE vol. 334, 18 August 1988, LONDON GB pages 631 - 633 MA, J., ET AL. 'Yeast activators stimulate plant gene expression' see the whole document ----	1-25
E	WO/A,9 309 237 (SANDOZ) 13 May 1993 see page 23 - page 24 -----	1,5,11, 12, 14-16, 22,23

**ANNEX TO THE INTERNATIONAL SEARCH REPORT
ON INTERNATIONAL PATENT APPLICATION NO.**

GB 9300764
SA 72487

This annex lists the patent family members relating to the patent documents cited in the above-mentioned international search report.
The members are as contained in the European Patent Office EDP file on
The European Patent Office is in no way liable for these particulars which are merely given for the purpose of information. 14/07/93

Patent document cited in search report	Publication date	Patent family member(s)	Publication date
WO-A-9309237	13-05-93	None	

EPO FORM P0479

For more details about this annex : see Official Journal of the European Patent Office, No. 12/82