

(19) World Intellectual Property Organization
International Bureau



(43) International Publication Date
29 December 2004 (29.12.2004)

PCT

(10) International Publication Number
WO 2004/114598 A1

- (51) International Patent Classification⁷: H04L 12/28, 12/56, 12/407
- (21) International Application Number: PCT/IB2004/050956
- (22) International Filing Date: 22 June 2004 (22.06.2004)
- (25) Filing Language: English
- (26) Publication Language: English
- (30) Priority Data: 03101876.5 25 June 2003 (25.06.2003) EP
- (71) Applicant (for DE only): PHILIPS INTELLECTUAL PROPERTY & STANDARDS GMBH [DE/DE]; Stein-damm 94, 20099 Hamburg (DE).
- (71) Applicant (for all designated States except DE, US): KONINKLIJKE PHILIPS ELECTRONICS N. V. [NL/NL]; Groenewoudseweg 1, NL-5621 BA Eindhoven (NL).
- (72) Inventors; and
- (75) Inventors/Applicants (for US only): HIERTZ, Guido [DE/DE]; c/o Philips Intellectual Property & Standards GmbH, Weissshausstr. 2, 52066 Aachen (DE). BAGUL,

Rajesh, Shantaram [IN/DE]; c/o Philips Intellectual Property & Standards GmbH, Weissshausstr. 2, 52066 Aachen (DE). WISCHHUSEN, Olaf [DE/DE]; c/o Philips Intellectual Property & Standards GmbH, Weissshausstr. 2, 52066 Aachen (DE). HABETHA, Jörg [DE/DE]; c/o Philips Intellectual Property & Standards GmbH, Weissshausstr. 2, 52066 Aachen (DE). MAY, Klaus, Peter [DE/DE]; c/o Philips Intellectual Property & Standards GmbH, Weissshausstr. 2, 52066 Aachen (DE).

(74) Agent: MEYER, Michael; Philips Intellectual Property & Standards GmbH, Weissshausstr. 2, 52066 Aachen (DE).

(81) Designated States (unless otherwise indicated, for every kind of national protection available): AE, AG, AL, AM, AT, AU, AZ, BA, BB, BG, BR, BW, BY, BZ, CA, CH, CN, CO, CR, CU, CZ, DE, DK, DM, DZ, EC, EE, EG, ES, FI, GB, GD, GE, GH, GM, HR, HU, ID, IL, IN, IS, JP, KE, KG, KP, KR, KZ, LC, LK, LR, LS, LT, LU, LV, MA, MD, MG, MK, MN, MW, MX, MZ, NA, NI, NO, NZ, OM, PG, PH, PL, PT, RO, RU, SC, SD, SE, SG, SK, SL, SY, TJ, TM, TN, TR, TT, TZ, UA, UG, US, UZ, VC, VN, YU, ZA, ZM, ZW.

(84) Designated States (unless otherwise indicated, for every kind of regional protection available): ARIPO (BW, GH,

[Continued on next page]

(54) Title: A METHOD OF DECENTRALIZED MEDIUM ACCESS CONTROL IN A COMMUNICATIONS NETWORK

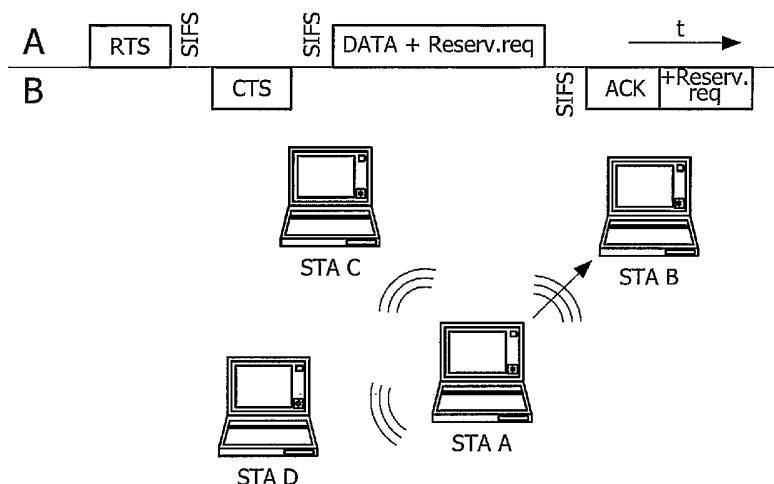

(57) Abstract: A method of decentralized medium access control in a communications network consisting of a plurality of stations, wherein a sending station transmits a reservation request for a future transmission to an intended receiving station, said intended receiving station being in a reception range of said sending station, said reservation request signalling reservation information including starting point and duration of the transmission, defining a time period of said future transmission, and, in case of a multi-channel system, frequency or code of the channel of said future transmission, so establishing a reservation, and stations active in said reception range overhear said reservation request and other stations than said intended receiving station perform the actions of storing said reservation information locally and defer from medium access during the time period and on the channel of the future transmission.

WO 2004/114598 A1



GM, KE, LS, MW, MZ, NA, SD, SL, SZ, TZ, UG, ZM, ZW), Eurasian (AM, AZ, BY, KG, KZ, MD, RU, TJ, TM), European (AT, BE, BG, CH, CY, CZ, DE, DK, EE, ES, FI, FR, GB, GR, HU, IE, IT, LU, MC, NL, PL, PT, RO, SE, SI, SK, TR), OAPI (BF, BJ, CF, CG, CI, CM, GA, GN, GQ, GW, ML, MR, NE, SN, TD, TG).

— *before the expiration of the time limit for amending the claims and to be republished in the event of receipt of amendments*

Published:

— *with international search report*

For two-letter codes and other abbreviations, refer to the "Guidance Notes on Codes and Abbreviations" appearing at the beginning of each regular issue of the PCT Gazette.

A method of decentralized medium access control in a communications network

5

The invention relates to a method of decentralized medium access control in a communications network consisting of a plurality of stations.

10

Wireless local area networks (WLANs) based on Institute of Electronics and Electrical Engineering (IEEE) 802.11 constantly conquer new markets, the home user market being the most important of them all. Despite WLANs in business use, a home WLAN will not offer infrastructure for the network. Therefore, all centralized support for Quality of Service (QoS) is of lower importance than in the business network. A decentralized support for QoS is needed.

15

In decentralized WLANs, no co-ordination instance can reserve the wireless medium for time bounded services. Co-ordination functions as the EDCF of 802.11e work on a probability driven basis, such that there is still the possibility of collisions on the wireless medium, not only between traffic derived from sources of the same priority, but also from different priorities. These collisions reduce the throughput as they generate overhead and increase the delay. For periodic real time traffic like VoIP it may even be unacceptable to tolerate this delay.

20

To the satisfaction of the home user, a new co-ordination function regarding multihop connections is needed. It shall combine multihop capability with the support for Quality of Service. Existing co-ordination functions for 802.11 are not useful for multihop connections, since they are designed for single hop connections only.

25

Therefore it is the object of the invention to overcome the disadvantages of the standard 802.11 collision avoidances and to propose a method of decentralized

30

medium access control to reserve the wireless medium to the needs of Quality of Service applications.

This object is solved by a method as defined in claim 1 and a communications network as defined in claim 13.

5 According to the invention, a method of decentralized medium access control in a communications network consisting of a plurality of stations offers that a sending station transmits a reservation request for a future transmission to an intended receiving station, said intended station being in a reception range of said sending station, said reservation request signalling reservation information including starting
10 point and duration of the transmission, defining a time period of said future transmission, and, in case of a multi-channel system, frequency or code of the channel of said future transmission, so establishing a reservation, and stations active in said reception range overhear said reservation request and other stations than said intended receiving station perform the actions of storing said reservation information locally and
15 defer from medium access during the time period and on the channel of the future transmission.

The invention foresees that stations which are planning a data transmission, announce the starting point in time, duration of the transmission and eventually even the frequency or code channel in a reservation packet. This reservation
20 packet is overheard by the other stations in the reception range of the sending station of the reservation request. The other stations store this information and defer from any medium access at the announced point in time on the respective frequency code channel and for the duration of the planned transmission.

In a preferred embodiment, said intended receiving station acknowledges
25 said reservation request by returning a message repeating said reservation information, and other stations than the intended receiving station active in the reception range for transmissions of said receiving station perform the actions of storing said reservation information locally and defer from medium access during the time period and on the channel of the future transmission upon overhearing said acknowledgement message.
30 Thereby, in order to clear the medium also on the receiver side, the reservation packet is sent back by the intended receiving station, when it is received from the sending station. By these means, the other stations in the reception range of the intended receiving

station are informed about the planned transmission of the sending station and can also defer from any medium access during the announced period.

The overhead of the reservation mechanism can be reduced by transmitting the reservation request piggy-back to normal data frames. Also said
5 acknowledgement message can be transmitted piggy-back in an acknowledgement frame of a data packet or another data packet.

In a further preferred embodiment, the reservation request includes information on the priority or priority class of the future transmission, said priority information being used in that active stations in said reception range of said sending
10 station replace an existing reservation information stored for the respective time period by new reservation information of a most recently received reservation request, if the existing reservation request has a lower priority than the most recently received reservation request; and the station that has been previously allocated the channel for the respective time period withdraws or delays its future transmission, if the most
15 recently received reservation has a higher priority.

Also, when the acknowledgement message includes information on the priority or priority class of the future transmission, the priority information is used in that active stations in the reception range of that receiving station replace an existing reservation information as explained above.

20 According to the decentralized nature of the new protocol different reservations may overlap or stations may wish to transmit at the same time. Therefore, a reservation collision resolution algorithm is needed. Each station which desires to reserve an interval is to check existent reservation entries in its local table. As each reservation belongs to a certain priority, the station checks the priority of its own
25 reservation request against the colliding reservation. If it has lower priority, the station has to defer its reservation request. This step may be repeated until a slot is found which fits the desired length of the stations own reservation duration. In case of reservation requests of the same priority, the older reservation request may be given higher priority.

In a preferred embodiment, several periodic transmissions can be
30 signalled by a single reservation request, and a time period derived from reservation information of a reservation request of a first future transmission being interpreted as period also of the following future transmissions and stations active in the reception

range overhear said reservation request and other stations than said intended receiving station perform the actions of storing said reservation information locally and defer from medium access during all signalled time periods on all respective channels of the future transmissions.

5 The signalled starting point of the future transmission can be defined relatively to the beginning or end of the sending time or the beginning or end of the time slot of said reservation request, so that no global synchronization of clocks is required. Correspondingly, when the starting point of the future transmission signalled in the acknowledgement message will be defined relatively to the beginning or end of the
10 sending time or the beginning or end of the time slot as a time base of said acknowledgement message, the starting point information from the sending station is adapted to the time base of said acknowledgement message.

Collisions of reservation requests can be resolved by a collision resolution mechanism, for example, a reservation request of shorter duration of
15 transmission can replace an existing reservation of longer duration of transmission, or reservation information of a most recent reservation request replaces an existing reservation, if the most recent reservation request has an earlier due time than the existing information.

If a reservation request is to be revoked, the sending station transmits a
20 revocation message to said intended receiving station for the purpose of deleting one or several of its reservation requests; and stations active in the reception range for transmissions of said sending station overhear said revocation message and other stations than said intended receiving station locally delete the corresponding reservation information. The intended receiving station can then acknowledge said revocation
25 message by returning a message repeating said revocation information; and other stations than the intended receiving station active in the reception range for transmissions of said receiving station perform the actions of locally deleting the reservation information corresponding to the revocation information.

It may also be provided that a station broadcasts a copy of its locally
30 stored reservation information; and stations active in the reception range for transmissions of said station compare the received reservation information with their locally stored information and add missing reservations to their locally stored

reservation information.

The invention also relates to a communications network consisting of a plurality of stations, wherein the method as described herein is used.

The invention will be further explained in detail with reference to the
5 accompanying drawings, wherein

Fig. 1 shows an example how the distributed reservation can be embedded in the frame structure of the IEEE 802.11 system; and
10 Fig. 2 shows an example of the data frame exchange including a reservation request.

In figure 1, the reservation information is included in the frame body.
15 Alternatively, the reservation information could also be included in the frame header. The reservation information consists of the following fields: - period of the traffic, - duration of the medium reservation, - priority of data transmission, - number of future reservation periods.

The period of the traffic informs other stations when the next frame will
20 be transmitted. The duration field informs other stations about the duration of the next data transmission of this stream, including time for the acknowledgement message. The priority field includes information about the traffic category this stream belongs to. By designating the priority of the future transmission, it is possible to support different Quality of Service levels in the network. In case that two transmissions are planned for
25 the same time period, the higher priority traffic will gain the medium access and the lower priority sending station will automatically withdraw or delay its reservation.

An optional field informs other stations about the number of future reservation periods to be made. This allows a station to make a periodic reservation by a single reservation packet. The period between two transmissions is given in the "period
30 of traffic" field, and the constant duration of each transmission in the "duration of the medium reservation" field.

As shown in figure 2, station (STA) A transmits a frame to station B. The

data frame also includes a reservation request. Station C and station D overhear this data transmission and copy the reservation request information. Thus they can set up a table of reservation requests. As already mentioned above, the receiving station will optionally repeat the reservation information in its acknowledgement message for the purpose of dealing with the hidden station problem. This acknowledgement message can be received by stations which are hidden to the sender and therefore might interfere during the reserved duration as they are in the reception range of the receiver but out of the reception range of the sending station.

With every overheard or received reservation request, every station updates its internal reservation request table, includes the most recently received reservation requests and eventually replaces an already stored reservation in case that the new reservation has a higher priority.

As different stations may independently chose different reservation periods and reservation duration, a collision avoidance mechanism is needed. First of all, the priority of the reservation request has to be considered. Stations requesting a reservation for a lower priority stream delay to higher priority streams. Stations requesting a reservation of the same priority may chose strategies like "shortest job first" or "first come, first serve" for collision avoidance. Conflicting reservation requests which partially overlap shall be reordered in the most efficient way. This may lead to increased delays for low priority streams, which must not delay VoIP frames etc. If still a reservation conflict occurs, the oldest reservation request shall be prioritised. New arriving reservation requests may not rule out old reservation requests.

Especially when every reservation request reserve only its succeeding frame, a revocation procedure for reservation requests is not generally needed. In case a large number reservation requests is made in advance, the next requested reservation may be used to transmit a revocation frame for the purpose of deleting reservation requests in other stations tables.

In addition to the reservation requests scheme described above, stations may also transmit their reservation request table in every beacon frame they generate. As all stations of an Independent Basic Service Set (IBSS) participate in the generation of a beacon frame, the station which generates the beacon frame may also transmit its local reservation request table inside the beacon to achieve a better synchronization of

the reservation request table of all stations. This may also help to achieve a coherent reservation request table between partial overlapping Basic Service Sets (BSS).

According to the invention, using the reservation information, every station of the BSS can predict transmissions from neighbouring stations and refrain
5 from channel access at the desired time. For the support of time bounded services, the protocol shall optionally allow a BSS wide etiquette that stations are not allowed to start any own transmission if the during of their own transmission does not end before the
beginning of the reservation. Therefore, the requested reservation will be safe from any delay. If this strict behaviour, which might decrease overall throughput, is not desired,
10 the station which requested the reservation will become a 1-persistent station. It has highest priority then, as it will start its own transmission immediately after the ongoing transmission.

The invention avoids time consuming, delay increasing and throughput decreasing collisions on the wireless medium. Especially multihop connections will
15 benefit from the protocol as it makes it possible to schedule transmissions and to behave more intelligent than just drawing a random number in trying to transmit after a random period. The benefit is the distribution of transmission intentions of neighbouring stations. This allows to further enhance the protocol by extensions which make use of the fact that the time of a future transmission is known.

CLAIMS:

1. A method of decentralized medium access control in a communications network consisting of a plurality of stations, wherein - a sending station transmits a reservation request for a future transmission to an intended receiving station, said intended receiving station being in a reception range of said sending station, said
5 reservation request signalling reservation information including starting point and duration of the transmission, defining a time period of said future transmission, and, in case of a multi-channel system, frequency or code of the channel of said future transmission, so establishing a reservation, and - stations active in said reception range
10 overhear said reservation request and other stations than said intended receiving station perform the actions of storing said reservation information locally and defer from medium access during the time period and on the channel of the future transmission.
2. The method of claim 1, wherein - said intended receiving station acknowledges said reservation request by returning a message repeating said reservation
15 information; and - other stations than the intended receiving station active in the reception range for transmissions of said receiving station perform the actions of storing said reservation information locally and defer from medium access during the time period and on the channel of the future transmission upon overhearing said
20 acknowledgement message.
3. The method of claim 1, wherein said reservation request is transmitted piggy-back to a data packet in a frame or in another signalling frame.
4. The method of claim 3, wherein said acknowledgement message is
25 transmitted piggy-back in an acknowledgement frame of said data packet or another data packet.

5. The method of claim 1, wherein said reservation request includes information on the priority or priority class of said future transmission, said priority information being used in that - active stations in said reception range of said sending station replace an existing reservation information stored for the respective time period by new reservation information of a most recently received reservation request, if the existing reservation request has a lower priority than the most recently received reservation request; and - the station that has been previously allocated the channel for the respective time period withdraws or delays its future transmission, if the most recently received reservation has a higher priority.

6. The method of claim 1, wherein said acknowledgement message includes information on the priority or priority class of said future transmission, said priority information being used in that - active stations in said reception range of said receiving station replace an existing reservation information stored for the respective time period by new reservation information of a most recently received reservation request, if the existing reservation request has a lower priority than the most recently received reservation request; and - that station that has been previously allocated the channel for the respective time period withdraws or delays its future transmission, if the most recently received reservation has a higher priority.

7. The method of claim 1 or 2, wherein several periodic transmissions are signalled by a single reservation request and - a time period derived from reservation information of a reservation request of a first future transmission being interpreted as period also of the following future transmissions, and - stations active in said reception range overhear said reservation request and other stations than said intended receiving station perform the actions of storing said reservation information locally and defer from medium access during all signalled time periods on all respective channels of the future transmissions.

30

8. The method of claim 1, wherein the signalled starting point of said future

transmission is defined relatively to a specific point in time associated with the reservation request message, like e.g. the beginning or end of the sending time or the beginning or end of the time slot of said reservation request, so that no global synchronization of clocks is required.

5

9. The method of claim 1, wherein said specific point in time, which serves as reference point for the definition of the starting time of the future transmission, is defined relatively to the beginning of the reservation request message and signalled inside the reservation request message.

10

10. The method of claim 2, wherein - the starting point of the future transmission signalled in the acknowledgement message is defined relatively to the beginning or end of the sending time or the beginning or end of the time slot as a time base of said acknowledgement message and - adapting starting point information from said sending station to the time base of said acknowledgement message.

15

11. The method of claim 1, wherein collisions of reservation requests are resolved by a collision resolution mechanism.

20

12. The method of claim 1, wherein a reservation request of shorter duration of transmission replaces an existing reservation of longer duration of transmission.

13. The method of claim 1, wherein reservation information of a most recent reservation request replaces an existing reservation if the most recent reservation request has an earlier due time than the existing information.

25

14. The method of claim 1, wherein - said sending station transmits a revocation message to said intended receiving station for the purpose of deleting one or several of its reservation requests; and - stations active in the reception range for transmissions of said sending station overhear said revocation message and other stations than said intended receiving station locally delete the corresponding reservation

30

information.

15. The method of claim 1, wherein - said intended receiving station acknowledges said revocation message by returning a message repeating said revocation
5 information; and - other stations than the intended receiving station active in the reception range for transmissions of said receiving station perform the actions of locally deleting the reservation information corresponding to the revocation information.

16. The method of claim 1, wherein - a station broadcasts a copy of its
10 locally stored reservation information; and - stations active in the reception range for transmissions of said station compare the received reservation information with their locally stored information and add missing reservations to their locally stored reservation information.

17. A communications network consisting of a plurality of stations, including
- a sending station which transmits a reservation request for a future transmission to an intended receiving station, said intended receiving station being in a reception range of said sending station, said reservation request signalling reservation information including starting point and duration of the transmission, defining a time period of said
20 future transmission, and, in case of a multi-channel system, frequency or code of the channel of said future transmission, so establishing a reservation, and - stations active in said reception range which overhear said reservation request, wherein other stations than said intended receiving station perform the actions of storing said reservation information locally and defer from medium access during the time period and on the
25 channel of the future transmission.

18. The communications network of claim 17, characterized in that - said intended receiving station acknowledges said reservation request by returning a message repeating said reservation information; and - other stations than the intended receiving
30 station active in the reception range for transmissions of said receiving station perform the actions of storing said reservation information locally and defer from medium access during the time period and on the channel of the future transmission upon overhearing

said acknowledgement message.

19. The communications network of claim 17, characterized in that said reservation request includes information on the priority or priority class of said future transmission, said priority information being used in that - active stations in said reception range of said sending station replace an existing reservation information stored for the respective time period by new reservation information of a most recently received reservation request, if the existing reservation request has a lower priority than the most recently received reservation request; and - the station that has been previously allocated the channel for the respective time period withdraws or delays its future transmission, if the most recently received reservation has a higher priority.

20. The communications network of claim 17, characterized in that said acknowledgement message includes information on the priority or priority class of said future transmission, said priority information being used in that - active stations in said reception range of said receiving station replace an existing reservation information stored for the respective time period by new reservation information of a most recently received reservation request, if the existing reservation request has a lower priority than the most recently received reservation request; and - that station that has been previously allocated the channel for the respective time period withdraws or delays its future transmission, if the most recently received reservation has a higher priority.

21. The communications network of claim 17, characterized in that several periodic transmissions are signalled by a single reservation request wherein a time period derived from reservation information of a reservation request of a first future transmission being interpreted as period also of the following future transmissions, and - stations active in said reception range overhear said reservation request and other stations than said intended receiving station perform the actions of storing said reservation information locally and defer from medium access during all signalled time periods on all respective channels of the future transmissions.

22. The communications network of claim 17, characterized in that - said sending station transmits a revocation message to said receiving station for the purpose of deleting one or several of its reservation requests; and - stations active in the reception range for transmissions of said sending station overhear said revocation message and other stations than said intended receiving station locally delete the corresponding reservation information.

23 The communications network of claim 17, characterized in that - said intended receiving station acknowledges said revocation message by returning a message repeating said revocation information; and - other stations than the intended receiving station active in the reception range for transmissions of said receiving station perform the actions of locally deleting the reservation information corresponding to the revocation information.

15 24. The communications network of claim 17, characterized in that - a station broadcasts a copy of its locally stored reservation information; and - stations active in the reception range for transmissions of said station compare the received reservation information with their locally stored information and add missing reservations to their locally stored reservation information.

20 25. A station which transmits a reservation request for a future transmission to an intended receiving station, said reservation request signalling reservation information including starting point and duration of the transmission, defining a time period of said future transmission, and, in case of a multi-channel system, frequency or 25 code of the channel of said future transmission, so establishing a reservation.

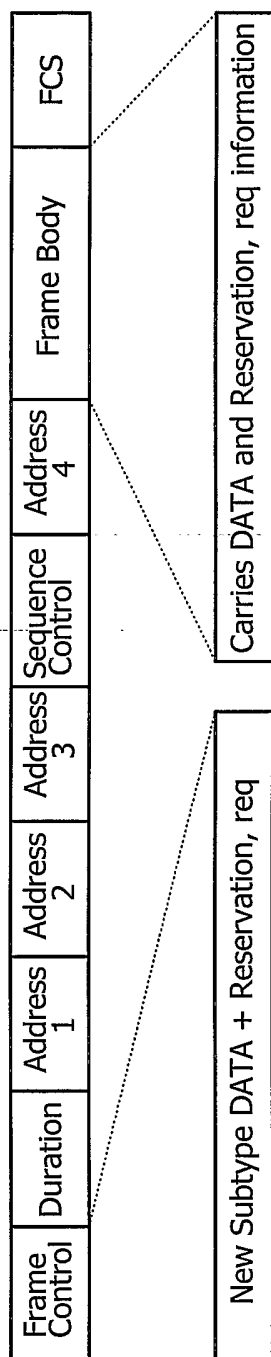

FIG. 1

2/2

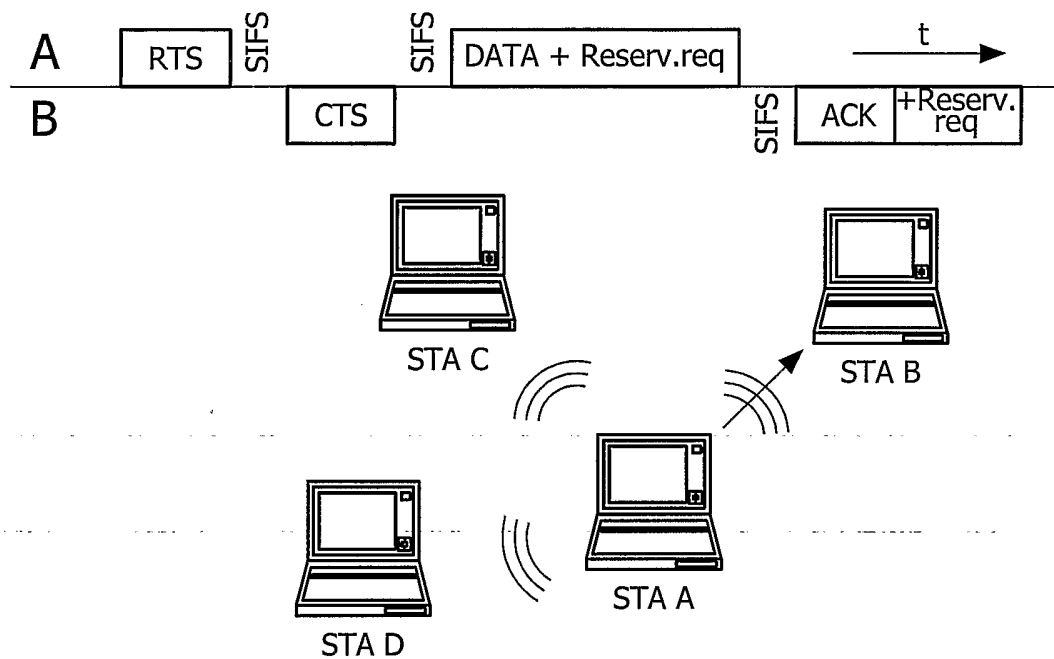

FIG. 2

INTERNATIONAL SEARCH REPORT

Int. Application No
PCT/IB2004/050956

A. CLASSIFICATION OF SUBJECT MATTER
IPC 7 H04L12/28 H04L12/56 H04L12/407

According to International Patent Classification (IPC) or to both national classification and IPC

B. FIELDS SEARCHED

Minimum documentation searched (classification system followed by classification symbols)
IPC 7 H04L

Documentation searched other than minimum documentation to the extent that such documents are included in the fields searched

Electronic data base consulted during the international search (name of data base and, where practical, search terms used)
EPO-Internal, WPI Data

C. DOCUMENTS CONSIDERED TO BE RELEVANT

Category °	Citation of document, with indication, where appropriate, of the relevant passages	Relevant to claim No.
X	WO 01/28170 A (BEYER DAVID A ; FULLMER CHANE L (US); GARCIA LUNA ACEVES J JOAQUIN (US) 19 April 2001 (2001-04-19) abstract	1-4,11, 17,18,25
Y	page 3, line 23 - page 4, line 9 page 6, line 10 - line 16 page 8, line 25 - page 11, line 15 page 15, line 1 - page 24, line 24; figures 1-4	5,6,12, 13,19,20
Y	----- US 2002/163933 A1 (BENVENISTE MATHILDE) 7 November 2002 (2002-11-07) abstract -----	5,6,12, 13,19,20
	----- -/-- -----	

Further documents are listed in the continuation of box C.

Patent family members are listed in annex.

° Special categories of cited documents :

"A" document defining the general state of the art which is not considered to be of particular relevance
"E" earlier document but published on or after the international filing date
"L" document which may throw doubts on priority claim(s) or which is cited to establish the publication date of another citation or other special reason (as specified)
"O" document referring to an oral disclosure, use, exhibition or other means
"P" document published prior to the international filing date but later than the priority date claimed

"T" later document published after the international filing date or priority date and not in conflict with the application but cited to understand the principle or theory underlying the invention
"X" document of particular relevance; the claimed invention cannot be considered novel or cannot be considered to involve an inventive step when the document is taken alone
"Y" document of particular relevance; the claimed invention cannot be considered to involve an inventive step when the document is combined with one or more other such documents, such combination being obvious to a person skilled in the art.
"&" document member of the same patent family

Date of the actual completion of the international search

15 September 2004

Date of mailing of the international search report

10.11.04

Name and mailing address of the ISA
European Patent Office, P.B. 5818 Patentlaan 2
NL - 2280 HV Rijswijk
Tel. (+31-70) 340-2040, Tx. 31 651 epo nl,
Fax: (+31-70) 340-3016

Authorized officer

Jimenez Hernandez, P

INTERNATIONAL SEARCH REPORT

International Application No
PCT/IB2004/050956

C.(Continuation) DOCUMENTS CONSIDERED TO BE RELEVANT		
Category	Citation of document, with indication, where appropriate, of the relevant passages	Relevant to claim No.
X	<p>WO 02/21769 A (NOKIA NETWORKS ; GARCIA LUNA ACEVES JOSE J (US); FULLMER CHANE (US)) 14 March 2002 (2002-03-14) abstract page 4, line 11 - page 6, line 4 page 9, line 24 - page 11, line 6; figure 2 page 22, line 21 - page 23, line 13; figures 1,2,4,7</p>	1-4,11, 17,18,25
X	<p>WO 95/01020 A (XIRCOM INC) 5 January 1995 (1995-01-05) abstract; figures 12-37 page 3, line 4 - page 7, line 24</p>	1-4,11, 17,18,25
A	<p>US 6 192 053 B1 (ANGELICO DEAN ET AL) 20 February 2001 (2001-02-20) the whole document</p>	1-6, 11-13, 17-20,25
A	<p>BHARGHAVAN V ET AL: "MACAW: A MEDIA ACCESS PROTOCOL FOR WIRELESS LAN'S" COMPUTER COMMUNICATION REVIEW, ASSOCIATION FOR COMPUTING MACHINERY. NEW-YORK, US, vol. 24, no. 4, 1 October 1994 (1994-10-01), pages 212-225, XP000477053 ISSN: 0146-4833 the whole document</p>	1-6, 11-13, 17-20,25
A	<p>WEINMILLER J ET AL: "Analyzing and improving the IEEE 802.11-MAC protocol for wireless LANs" MODELING, ANALYSIS, AND SIMULATION OF COMPUTER AND TELECOMMUNICATION SYSTEMS, 1996. MASCOTS '96., PROCEEDINGS OF THE FOURTH INTERNATIONAL WORKSHOP ON SAN JOSE, CA, USA 1-3 FEB. 1996, LOS ALAMITOS, CA, USA, IEEE COMPUT. SOC, US, 1 February 1996 (1996-02-01); pages 200-206, XP010161831 ISBN: 0-8186-7235-8 the whole document</p>	1-6, 11-13, 17-20,25

INTERNATIONAL SEARCH REPORT

International application No.
PCT/IB2004/050956

Box II Observations where certain claims were found unsearchable (Continuation of item 2 of first sheet)

This International Search Report has not been established in respect of certain claims under Article 17(2)(a) for the following reasons:

1. Claims Nos.:
because they relate to subject matter not required to be searched by this Authority, namely:

2. Claims Nos.:
because they relate to parts of the International Application that do not comply with the prescribed requirements to such an extent that no meaningful International Search can be carried out, specifically:

3. Claims Nos.:
because they are dependent claims and are not drafted in accordance with the second and third sentences of Rule 6.4(a).

Box III Observations where unity of invention is lacking (Continuation of item 3 of first sheet)

This International Searching Authority found multiple inventions in this international application, as follows:

see additional sheet

1. As all required additional search fees were timely paid by the applicant, this International Search Report covers all searchable claims.

2. As all searchable claims could be searched without effort justifying an additional fee, this Authority did not invite payment of any additional fee.

3. As only some of the required additional search fees were timely paid by the applicant, this International Search Report covers only those claims for which fees were paid, specifically claims Nos.:

4. No required additional search fees were timely paid by the applicant. Consequently, this International Search Report is restricted to the invention first mentioned in the claims; it is covered by claims Nos.:

1-6, 11-13, 17-20, 25

Remark on Protest

- The additional search fees were accompanied by the applicant's protest.
- No protest accompanied the payment of additional search fees.

FURTHER INFORMATION CONTINUED FROM PCT/ISA/ 210

This International Searching Authority found multiple (groups of) inventions in this international application, as follows:

1. claims: 1-6,11-13,17-20,25

Prioritizing of transmissions in a decentralized medium access control method and corresponding network according to claims 1 and 17 respectively.

1.1. claims: 2, 18

acknowledgement of reservation request

1.2. claims: 3,4

piggy-backing of reservation request/response

1.3. claim: 11

use of collision resolution mechanism for reservation request collisions

2. claims: 1,7,17,21

Reservation of periodic transmissions in a decentralized medium access control method and corresponding network according to claims 1 and 17 respectively.

3. claims: 1,8,9,10

Signalling of timing information regarding future transmission starting point in a decentralized medium access control method according to claim 1.

4. claims: 1,14-17,22-24

Use of revocation and/or update messages in a decentralized medium access control method and corresponding network according to claims 1 and 17 respectively.

INTERNATIONAL SEARCH REPORT

Inte Application No
PCT/IB2004/050956

Patent document cited in search report		Publication date	Patent family member(s)	Publication date
WO 0128170	A	19-04-2001	US 6788702 B1	07-09-2004
			AU 776640 B2	16-09-2004
			AU 2296901 A	23-04-2001
			CA 2390061 A1	19-04-2001
			EP 1249101 A2	16-10-2002
			WO 0128170 A2	19-04-2001
			US 2002163933	A1
			WO 03041428 A1	15-05-2003
			WO 03041427 A1	15-05-2003
			WO 03041343 A2	15-05-2003
			WO 03043357 A1	22-05-2003
			WO 03039054 A2	08-05-2003
			US 2002154653 A1	24-10-2002
			EP 1338125 A2	27-08-2003
			WO 0237754 A2	10-05-2002
WO 0221769	A	14-03-2002	AU 8866601 A	22-03-2002
			WO 0221769 A2	14-03-2002
WO 9501020	A	05-01-1995	AU 7210894 A	17-01-1995
			WO 9501020 A1	05-01-1995
			US 5838730 A	17-11-1998
			US 5729680 A	17-03-1998
			US 5717688 A	10-02-1998
			US 5875186 A	23-02-1999
US 6192053	B1	20-02-2001	US 2002006123 A1	17-01-2002