

Feb. 7, 1967

TAKESHI EGUCHI

3,302,294

SLIDING CALIPERS PROVIDED WITH DIAL GAUGE

Filed Sept. 18, 1964

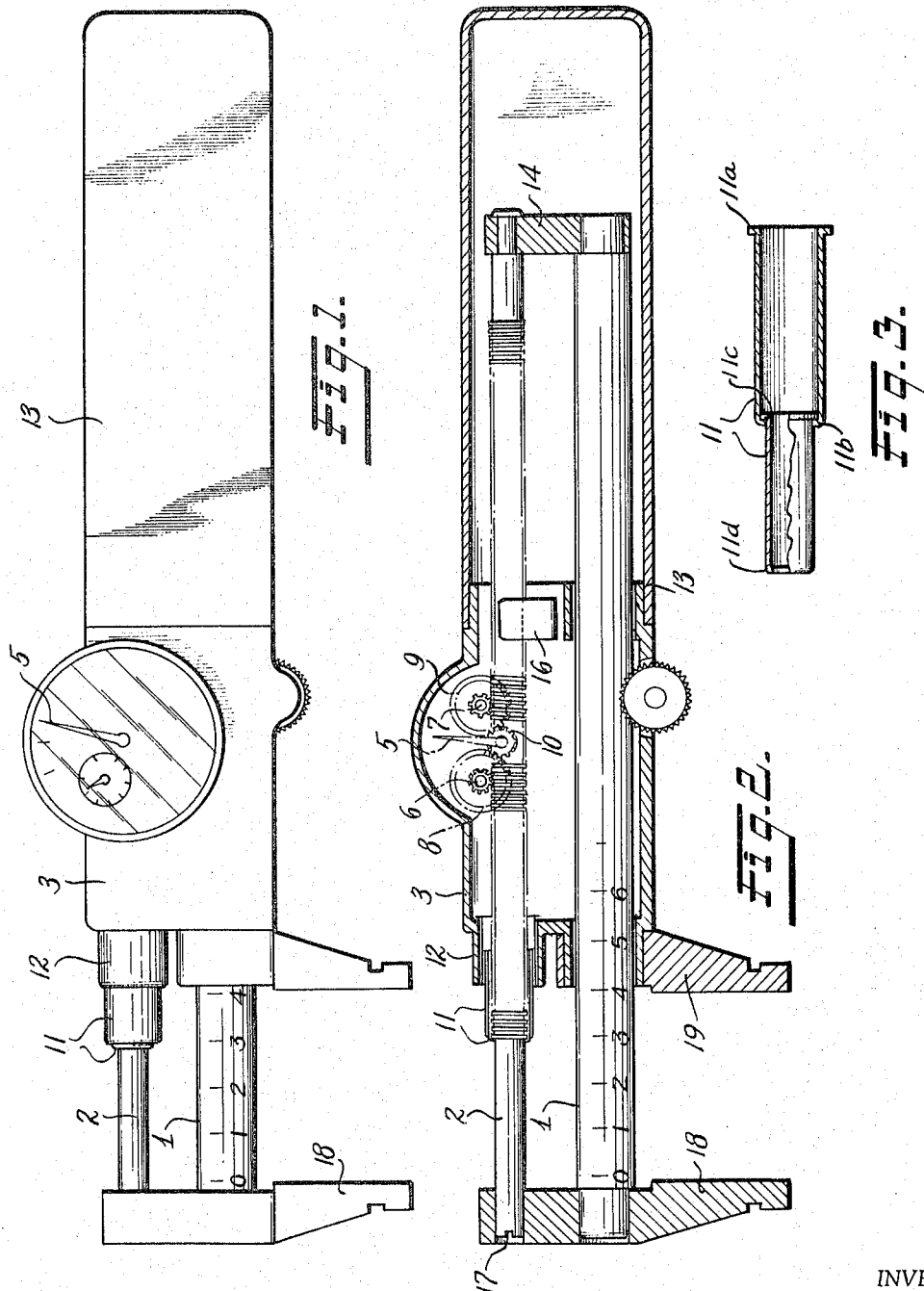

INVENTOR

Takeshi Eguchi

BY *Holcombe, Wetherill & Grisctois*

ATTORNEY.

1

2

3,302,294
**SLIDING CALIPERS PROVIDED WITH
DIAL GAUGE**

Takeshi Eguchi, Utsunomiya, Japan, assignor to Yehan Numata, Tsurumi-ku, Yokohama, Japan
Filed Sept. 18, 1964, Ser. No. 397,554
Claims priority, application Japan, Oct. 15, 1963, 38/77,297
3 Claims. (Cl. 33-147)

This invention relates to sliding calipers provided with a dial gauge enclosed in a dust-proof case.

In conventional sliding calipers having a dial gauge the rack meshing with the pinion of the dial gauge is exposed so that filings and dust may penetrate thereto, with consequent sticking of the slider or inaccuracy of the gauge pointer. In the present invention, which completely alters the traditional shape and structure of such devices, the rack meshing with the pinion is completely covered for dust protection.

A preferred embodiment of the invention will now be described, purely by way of illustration, in conjunction with the accompanying drawings, in which:

FIG. 1 is a plan view of calipers exemplifying the invention;

FIG. 2 is a central longitudinal section taken in a plane parallel to that of FIG. 1; and

FIG. 3 is a detail view showing the front end of the extensible cover portion, with a part thereof broken away.

Like reference numerals denote like parts throughout the several views.

Referring now to FIGS. 1 and 2, it will be seen that the calipers comprise parallel rods 1 and 2, connected at one end by one jaw 18 of the calipers and at the other end by the bridge member 14. Rod 1 is smooth and slides in the body member 3. Rod 2 also slides in the body member 3, but is provided with a threaded portion which meshes with the small gears 6, 7. Gear 8 is mounted coaxially of gear 6, but is free to turn relatively thereto. Another large gear 9 is mounted coaxially of the small gear 7, and both gears 8 and 9 mesh with the pinion 10 fixed to the pointer 5.

The body member 3 is provided with a bore 12 and seated in this bore is a telescopic cover 11 which encircles the threaded rod 2, thus permitting it to slide relatively to the bore and protecting it from dust and dirt. As shown in FIG. 3, the cover 11 is composed of two telescoping tubes, a larger cylindrical tube and a smaller cylindrical tube, the latter being slidably mounted in the former. The larger tube is provided at one end with a flange 11a and the other end of the larger tube is provided with a bore constriction 11b. The function of the constriction is to act as a stop against flange 11c on one end of the smaller tube and thus prevent the latter from being drawn all the way out of the large tube when moved to the left, as illustrated in FIG. 3. Any number of such telescopic covers of various diameters may be so prepared and assembled as shown in FIG. 3. The external diameter of the inner tube member 11b preferably should be slightly smaller in diameter than the bore of outer tube 11 in order to slide freely therein. The flange 11c should be of a diameter greater than the constriction in the outer tube. The entire telescopic cover is mounted firmly in the bore 12, but is not necessarily fixed thereto. Preferably stop means is provided to restrain movement of the cover 11 toward the dial gauge. A fixed cover 13 covers the other end of the body member and the associated ends of the rods 1 and 2.

The threaded rod 2 slides in a guide 16 and is provided at its exposed end with a slot 17 by means of which it can be turned in the bridge 14 for zero point regulation.

The movable jaw 18 cooperates with a fixed jaw 19 carried by the body member 3.

It will be noted from the drawings that the threaded portion of the rod 2 is slightly larger in diameter than the remainder of this rod and that the smallest section of the telescopic cover 11 carries an inwardly projecting flange which catches on the end of said threaded portion to extend the telescopic cover as the rod 2 is drawn out of the body member 3, and that the gears and the threaded portion of the rod 2 are completely enclosed.

What is claimed is:

1. In sliding calipers of the type comprising a hollow body, a dial gauge carried on said body, gear means within said body for controlling said gauge, a stationary first jaw carried by said body, a second jaw outside said body movable with respect to said first jaw, rod means connected to said movable jaw which extends into said body, means on said rod to turn said gears, a stop on said rod outwardly of said turning means, said body being provided with an aperture through which said rod extends, the improvement which comprises a tubular cover encircling said rod and extending through said aperture, said cover having one end formed to catch on said stop on said rod while its other end is formed to catch on the inner edge of said aperture, said cover comprising at least two relatively telescopic tubular portions, the innermost of which catches on said stop, while the outermost catches on said aperture, said portions being of sufficient length to retain a telescopic relationship when the jaws are in a fully open position.

2. In sliding calipers of the type comprising a hollow body, a dial gauge carried on said body, gear means within said body for controlling said gauge, a stationary first jaw carried by said body, a second jaw outside said body movable with respect to said first jaw, rod means connected to said movable jaw which extends into said body, means on said rod to turn said gears, a stop on said rod outwardly of said turning means, said body being provided with an aperture through which said rod extends, the improvement which comprises an extensible tubular cover encircling said rod and extending into said aperture, said cover comprising at least two relatively telescopic tubular portions, the innermost of which catches on said stop at its outer end, while the outermost of which catches on the inner end of said aperture at its inner end, said portion being of sufficient length to retain a telescopic relationship when the jaws are in a fully open position.

3. Calipers as claimed in claim 2 in which said body comprises portions enclosing said gears and the end of said rod means remote from said movable jaw.

References Cited by the Examiner

UNITED STATES PATENTS

60	1,621,526	3/1927	Culell	33-147
	1,703,736	2/1929	Jacob	33-143
	1,878,990	9/1932	Sigsbey et al.	33-163
	2,846,769	8/1958	Colont	33-147 X

FOREIGN PATENTS

65	179,910	7/1923	Great Britain.
----	---------	--------	----------------

LEONARD FORMAN, *Primary Examiner.*

S. S. MATTHEWS, *Assistant Examiner.*