



(11) **EP 2 030 923 B1**

(12) **EUROPEAN PATENT SPECIFICATION**

(45) Date of publication and mention of the grant of the patent:
03.10.2012 Bulletin 2012/40

(51) Int Cl.:
B65H 5/22 (2006.01)

(21) Application number: **08014931.3**

(22) Date of filing: **22.08.2008**

(54) **Apparatus and method for printing and/or electronically scanning dual face surfaces of a sheet/mailpiece**

Vorrichtung und Verfahren zum Drucken und/oder elektronischen Scannen von doppelseitigen Oberflächen eines Blattes/einer Postsendung

Appareil et procédé d'impression et/ou de balayage électronique de surfaces à double face d'une feuille/pli postal

(84) Designated Contracting States:
DE FR GB

(30) Priority: **31.08.2007 US 848968**

(43) Date of publication of application:
04.03.2009 Bulletin 2009/10

(73) Proprietor: **Pitney Bowes, Inc.**
Stamford, CT 06926-0700 (US)

(72) Inventor: **Ong, Henson C.**
Waterbury, Connecticut 06708 (US)

(74) Representative: **HOFFMANN EITLE**
Patent- und Rechtsanwälte
Arabellastrasse 4
81925 München (DE)

(56) References cited:
US-A- 4 433 599 **US-A- 6 139 004**
US-A1- 2004 251 606

EP 2 030 923 B1

Note: Within nine months of the publication of the mention of the grant of the European patent in the European Patent Bulletin, any person may give notice to the European Patent Office of opposition to that patent, in accordance with the Implementing Regulations. Notice of opposition shall not be deemed to have been filed until the opposition fee has been paid. (Art. 99(1) European Patent Convention).

Description

[0001] This invention relates to apparatus for manipulating sheet material and, more particularly, to an apparatus for providing equal access to dual face surfaces of a sheet/mailpiece for printing/scanning on each side thereof.

[0002] Material handling systems frequently require that sheet material, such as the internal mailpiece contents or mailpiece envelopes, be turned over to match a specific downstream requirement. For example, mailpiece fabrication equipment typically requires that mailpiece content material be oriented face-up or face down depending upon the orientation of a receiving envelope. This requirement has come under increasing demand as new and old equipment have, over the course of time, been merged. That is, some mailpiece fabrication systems require a face-up orientation while others employ a face-down presentation. Effective utilization and coordination of all systems/machines becomes inefficient when specific mailpiece fabrication jobs can only be processed on specific machines.

[0003] US-A-6 139 004 describes a material strip handling apparatus comprising a lower vacuum conveyor and an upper vacuum conveyor. The lower vacuum conveyor conveys the strips of material which desirably are evenly spaced on the conveyance surface. In particular, the vacuum of the conveyor holds the strips of material with a controlled vacuum via a vacuum chamber. More specifically, the vacuum of the lower conveyor holds the strips of material with a controlled vacuum to a tangent region of the lower vacuum conveyor with the upper vacuum conveyor. At the tangent region, the strips of material are individually and successively transferred onto the upper vacuum conveyor. At or near the tangent region, the vacuum of the lower vacuum conveyor is extinguished or otherwise ceases to hold the material strips thereto by vacuum means. Similarly, at or near the tangent region, a vacuum is created, generated or provided within the upper vacuum conveyor. Such vacuum may be so provided by means of a vacuum chamber or box and an associated vacuum-supplying hose or duct. The application of such a vacuum serves to hold the material strips adjacent the conveyance surface.

[0004] Furthermore, various inversion modules have been developed to reorient the envelope or mailpiece content material for printing or scanning purposes. That is, a requirement often exists for a mailpiece envelope to have information printed on both face surfaces such as a destination address on one side thereof and a return address on the other side (typically on the rear face of the envelope flap). At other times, a sheet may have content material printed on one side while a destination address is printed on the opposite side such that, when folded, the destination address may be aligned with and seen through a transparent window of an envelope.

[0005] One apparatus for inverting the orientation of a mailpiece envelope, or its content material, includes a

twist module wherein the sheet material is directed linearly along a spiral path, typically affected by a series of twisted belts or chords. While such twist modules retain the respective leading and trailing edge position of the sheet material, such modules require a lengthy axial path to change the face-up/ face-down orientation of the sheet material. Furthermore, twist modules are not reconfigurable to handle straight runs wherein sheet material inversion is not required. Consequently, a substitute module or entirely separate mechanism must be introduced to reconfigure the sheet material handling equipment.

[0006] A need, therefore, exists for an apparatus to manipulate sheet material for providing access to the dual face surfaces of the sheet material and for performing additional processing operations such as printing and/or scanning information on each side of the sheet material.

[0007] According to the invention, there is provided a sheet handling apparatus for conveying sheet material along a feed path, comprising, first and second conveyor modules having first and second conveyor surfaces, respectively, for driving the sheet material along the feed path, the conveyor modules being arranged such that at least a portion of the first conveyor surface opposes at least a portion of the second conveyor surface along a face-to-face interface; a means for developing a pressure differential across the first and second conveyor surfaces to hold the sheet material on one of the conveyor surfaces and transfer the sheet material from the first to the second conveyor surfaces during transport; and a processor operative to independently control the pressure differential means such that sheet material may be transferred from one conveyor module to the other conveyor module by controlling the pressure differential developed across each of the first and second conveyor surfaces when the sheet material is interposed between the face-to-face interface, wherein the first and second conveyor surfaces each include a plurality of openings therein, and wherein the pressure differential means associated with each of the first and second conveyor modules includes first and second pneumatic pump and a plenum defining first and second chambers disposed in fluid communication with respective pneumatic pumps, each chamber, furthermore, defining a sidewall structure having a plurality of apertures therein disposed adjacent the respective conveyor surface such that air may pass through the openings thereof and through the apertures of the plenum to produce a pressure differential across the conveyor surface, the first pneumatic pump being disposed in fluid communication with the first chamber and the second pneumatic pump being disposed in fluid communication with the second chamber, and wherein the second pneumatic pump is independently controllable by the processor to produce a neutral or positive pressure differential across a portion of the conveyor surface corresponding to the face-to-face interface to transfer sheet material from one conveyor module to the other conveyor module.

[0008] The accompanying drawings illustrate presently preferred embodiments of the invention and, together

with the detailed description given below, serve to explain the principles of the invention. As shown throughout the drawings, like reference numerals designate like or corresponding parts.

Figure 1 is a perspective view of a sheet handling apparatus according to the present invention including first and second conveyor modules each having a conveyor surface which lies face-to-face along at least a portion thereof such that sheet material may be conveyed and transferred from one module to the other.

Figure 2 is a top view of the first and second conveyor modules wherein a pneumatic pressure source develops a negative, positive or neutral pressure differential across the respective conveyor surfaces to accept, hold and release sheet material along the conveyor surface.

Figure 3 depicts an enlarged top view of the conveyor modules wherein a processor controls the pneumatic pressure source such that a negative pressure differential, or vacuum, is developed to secure sheet material to the conveyor surfaces during transport.

Figure 4 depicts the top view of Figure 3 wherein the processor controls the pneumatic pressure source to neutralize the pressure differential across the first conveyor surface (i.e., along the face-to-face interface) while a negative pressure differential is developed across the second conveyor surface to transfer the released sheet material from first conveyor module to the opposing second conveyor module.

Figure 5 depicts the top view of Figure 3 wherein the processor controls the pneumatic pressure source to develop a positive pressure differential across the first conveyor surface (i.e., along the face-to-face interface) while a negative pressure differential is developed across the second conveyor surface to transfer the released sheet material from first conveyor module to the opposing second conveyor module.

[0009] The invention will be fully understood when reference is made to the following detailed description taken in conjunction with the accompanying drawings.

[0010] A sheet handling apparatus is provided for conveying sheet material/mailpieces along a feed path which facilitates access to the dual face surfaces thereof for the purpose of printing, and/or scanning information contained, thereon. The sheet handling apparatus includes first and second conveyor modules each having a conveyor surface, a portion of which is disposed in opposing, face-to-face relation with a portion of the other conveyor surface. Furthermore, the conveyor surfaces cooperate with a means for developing a pressure differential across the conveyor surfaces to hold the sheet material on the conveyor surfaces and transfer the sheet material across the modules during transport. A processor controls the pressure differential means such that the sheet

material is held against the conveyor surfaces by a negative pressure differential developed across the conveyor surface and transferred from one conveyor surface to the other by controlling the pressure differential of both modules when the sheet material is interposed between the face-to-face interface. Furthermore, the remaining end portions of each conveyor surface are oppositely disposed and openly accessible to perform other sheet material processes. For example, the sheet material may be scanned along and/or printed on each face surface.

[0011] An apparatus is described for handling sheet material which enables access to both sides thereof for performing additional operations. Though, in the broadest sense of the invention, the apparatus enhances the ability to manipulate and/or handle sheet material along a continuous feed path while facilitating other sheet material processing operations such as printing, scanning, collation, cutting, folding, insertion, etc. In the context used herein, "sheet material" means any page, document, or media wherein the dimensions and stiffness properties in a third dimension are but a small fraction, e.g., 1/100th of the dimensions and stiffness characteristics in the other two dimensions. As such, the sheet material is substantially "flat" and flexible about axes parallel to the plane of the sheet. Hence, in addition to individual sheets of paper, plastic or fabric, objects such as envelopes and folders may also be considered "sheet material" within the meaning herein. The embodiments disclosed herein, therefore, are merely illustrative of the inventive teachings and should not be construed as limiting the invention to a particular type or construction of sheet material, but interpreted broadly in context of the specification and appended claims.

[0012] The invention employs two principle features including the ability to share/transport documents along a common, coplanar feed path, and a system configuration which enables access to both sides of a document for performing additional operations such as printing and/or scanning. Figure 1 shows an isolated perspective view of the sheet handling apparatus 10 according to the present invention. The sheet handling apparatus 10 includes first and second conveyor modules 12, 14 each having roller-driven conveyor surfaces 12C, 14C, a means 16 for developing a pressure differential across the conveyor surfaces 12C, 14C of the conveyor modules 12, 14, and a processor 20 for independently controlling the pressure differential means 16.

[0013] More specifically, the conveyor modules 12, 14 are arranged such that an end portion of one conveyor surface 14C opposes the other conveyor surface 12C along a face-to-face interface FF. Furthermore, while the remaining portions 12EP, 14EP of the conveyor modules 12, 14 are diametrically opposite, i.e., 180° out-of-phase, the end portions 12EP, 14EP are openly accessible for other sheet material processes. The import of this arrangement/feature will be discussed in greater detail in subsequent paragraphs when discussing the operation for controlling the sheet handling apparatus.

[0014] To facilitate the description, only one of the conveyor modules, e.g., the first conveyor module 12 will be described inasmuch as the structural configuration of each module is essentially identical. Furthermore, when structural elements are common to both modules 12, 14, a similar/common reference numeral or character will be employed for identification purposes. In Figures 1 and 2, the conveyor surface 12C is composed of a flexible material which is porous or includes a plurality of openings/apertures 12CO to permit the passage of air there-through. The conveyor surface 12C is furthermore, disposed about a pair of rollers 22, 24 to produce linear surface segments 26 between the rollers 22, 24. Moreover, the rollers 22, 24 are driven in the direction of arrows D, though the motor(s) for driving the rollers 22, 24 is not shown.

[0015] The means 16 for developing a pressure differential across the conveyor surface 12C includes, inter alia, one or more pneumatic pumps S_1 , S_2 and a plenum 30 disposed in fluid communication with the pneumatic pumps S_1 , S_2 . The plenum 30 is disposed between the linear segments 26 of the conveyor surface 12C and the rollers 22, 24 at each end of the conveyor module 12. The plenum 30 includes a plurality of apertures 30A disposed through a sidewall structure 30W of the plenum 30. Furthermore, the sidewall structure 30W is disposed adjacent the conveyor surface 12C and, in addition to tensile loads which may be imposed by the rollers 22, 24 on the conveyor surface 12C, the sidewall structure 30W provides a degree of lateral and/or vertical support for the conveyor surface 12C. Moreover, the apertures 30A are sufficiently close to the conveyor surface 12C such that air/fluid will flow substantially normal to the conveyor surface 12C (i.e., through the openings 12CO) rather than in a direction parallel to and/or between the sidewall structure 30W and the interior conveyor surface 12C.

[0016] Finally, the plenum 30 comprises at least one chamber 34-1, but may include additional chambers 34-2 to facilitate the transfer of sheet material from an upstream conveyor module 12 to a downstream conveyor module 14. The significance and use of a multi-chambered plenum 30 will become apparent when discussing the operation of the sheet handling apparatus 10

[0017] The pneumatic pumps S_1 , S_2 are capable of generating a positive, negative and/or neutral pressure differential, P, V, N, respectively, across the conveyor surface 12C. For example, to develop a negative pressure differential V, a command or signal is issued by the processor 20 to the pneumatic pumps S_1 , S_2 to generate a vacuum V (see Fig. 2) or low pressure within one or both of the chambers 34-1, 34-2. The higher atmospheric pressure, externally of the chambers 34-1, 34-2, effects fluid flow through the openings 12CO of the conveyor surface 12C and the apertures 30A of the plenum 30.

[0018] In Figures 3 and 4, the operation for controlling the sheet handling apparatus 10 is depicted. While sheet material 40 may be adequately conveyed and handled by conveyor modules having a single-chambered ple-

num, the figures emphasize the advantages of a multi-chambered plenum 30 to enhance the control/transfer of sheet material from one conveyor module 12 to another module 14. In Figure 3, sheet material 40 is introduced and is held against the conveyor surface 12C of the first conveyor module 12 by a vacuum V created in the chambers 34-1 and 34-2 of the plenum 30. The pressure differential is maintained across the conveyor surface 12C by the fluid communication established between the apertures 30A of the sidewall structure 30W and the openings 12CO of the conveyor surface 12C, i.e., even as the conveyor surface 13C slides across the sidewall surface 30W. Even as the conveyor surface 12C transitions from one chamber 34-1 to the next 34-2, the sheet material 40 continues to be urged against the conveyor surface 12C inasmuch as the pneumatic pump S_2 continues to draw a vacuum in the second chamber 34-2.

[0019] In Figure 4, when the sheet material 40 is conveyed to the interface FF, i.e., the area where the conveyor surfaces 12C and 14C are face-to-face, the pneumatic pump S_2 is de-activated so as to neutralize the pressure, denoted by the encircled N within the chamber 34-2. At the same time or simultaneously, a vacuum V is created or has been maintained in the first chamber 34-1 of the second conveyor module 14. Consequently, the sheet material 40 is transferred from the first conveyor module 12 to the second conveyor module 14. And, subsequently, a vacuum V maintained in the second conveyor module continues the transport of the sheet material 40 along the feed path FP.

[0020] Alternatively, and referring to Fig. 5, a positive pressure differential P may be established in the second chamber 34-2 of the first conveyor module 12. More specifically, a negative pressure differential may be maintained in both first and second chambers 34-1, 34-2, via the first and second pneumatic pumps S_1 , S_2 until a sheet of material 40 has fully entered the interface region, between the first and second conveyors 12, 14. Various sensing apparatus may be employed, e.g., leading edge photo-optic sensors (not shown), to detect the position of the sheet material 40 along the feed path FP. When it is determined that the sheet material 40 is correctly positioned, the pneumatic pump S_2 converts to pressurize the chamber 34-2 and produce a positive pressure differential across the conveyor surface 12C. As such, the sheet material 40 is urged from the conveyor surface 12C to the opposing conveyor surface 14C. Inasmuch as the conveyor surface 14C is drawing a vacuum, the negative pressure differential maintains the sheet material 40 in position as it continues along the feed path, i.e., provided by the conveyor surface 14C of the second module 14.

[0021] In addition to providing a means for conveying sheet material, various processing devices may be disposed adjacent each of the accessible end portions 12EP, 14EP of the conveyor surfaces 12C, 14C. For example, if the conveyor modules are processing mailpieces, various mailpiece processing operations may be performed on the exposed face surfaces of the mailpieces.

For example, a first printer 50a (see Figs. 1 and 2) disposed adjacent the first exposed end portion 12EP of the first conveyor surface 12C may print a destination address on one side of a mailpiece envelope 54 traveling along the first conveyor surface 12C, and a second printer 50b disposed adjacent the second exposed end portion 14EP of the second conveyor surface 14C may print a return address on the opposite side of the envelope 54 as it travels along the second conveyor surface 14C. Alternatively, or additionally, a first scanner 60a (located adjacent to or substituting for the printer 50a) may scan or read information contained on one side of the mailpiece envelope 54 while a second scanner 60b may scan or read information contained on the opposite side of the envelope 54.

[0022] In summary, the present invention provides an apparatus for transferring sheet material from one conveyor surface to another. Complexity is minimized and reliability optimized by reducing the number of moving parts. That is, aside from a common conveyor system, the apparatus employs a pneumatic system to hold, transfer and convey the sheet material. Moreover, the apparatus provides access to dual face surfaces of the sheet material, e.g., a mailpiece envelope, to perform various other processing operations such as printing and/or scanning.

[0023] Although the invention has been described with respect to a preferred embodiment thereof, it will be understood by those skilled in the art that the foregoing and various other changes, omissions and deviations in the form and detail thereof may be made without departing from the scope of the appended claims. For example, while the apparatus 10 shows only two conveyor modules 12, 14 disposed in linear, coplanar relationship, multiple conveyor modules, e.g., three modules, may be joined in overlapping relation to return the sheet material 40 to its original orientation, i.e., face up or face down. Furthermore, while the invention shows a substantially linear feed path, it should be understood that the upstream and downstream modules 12, 14 need not be linear or aligned, but may be staggered or misaligned, i.e., forming an angle relative to each other.

[0024] Moreover, the invention has been described in the context of a device wherein processing operations, whether in connection with a mailpiece 40 or other sheet of material, may be performed along an open or accessible portion of one of the conveyor surfaces 12C, 14C or conveyor modules 12, 14. It should also be appreciated that the sheet handling apparatus 10 is a device capable of transporting sheet material 40 along a co-planar feed path which prepares or presents the sheet material 40 in a suitable orientation for use by a downstream processing device. That is, the sheet handling apparatus 10 may be used to convey, transfer and deliver sheet material so as to present one face surface or another to a subsequent processing station including, but not limited to a printing and/or scanning station.

Claims

1. A sheet handling apparatus (10) for conveying sheet material along a feed path (FP), comprising,
 - first and second conveyor modules (12, 14) having first and second conveyor surfaces (12C, 14C), respectively, for driving the sheet material along the feed path, the conveyor modules (12, 14) being arranged such that at least a portion of the first conveyor surface (12C) opposes at least a portion of the second conveyor surface (14C) along a face-to-face interface (FF);
 - a means (16) for developing a pressure differential across the first and second conveyor surfaces (12C, 14C) to hold the sheet material on one of the conveyor surfaces and transfer the sheet material from the first to the second conveyor surfaces during transport; and
 - a processor (20) operative to independently control the pressure differential means such that sheet material may be transferred from one conveyor module (12) to the other conveyor module (14) by controlling the pressure differential developed across each of the first and second conveyor surfaces (12C, 14C) when the sheet material is interposed between the face-to-face interface (FF), wherein the first and second conveyor surfaces (12C, 14C) each include a plurality of openings (12CO) therein, and wherein the pressure differential means associated with each of the first and second conveyor modules includes first and second pneumatic pump (S1, S2) and a plenum (30) defining first and second chambers (34-1, 34-2) disposed in fluid communication with respective pneumatic pumps (S1, S2), each chamber, furthermore, defining a sidewall structure (30W) having a plurality of apertures (30A) therein disposed adjacent the respective conveyor surface (12C, 14C) such that air may pass through the openings (12CO) thereof and through the apertures (30A) of the plenum (30) to produce a pressure differential across the conveyor surface, the first pneumatic pump (S1) being disposed in fluid communication with the first chamber (34-1) and the second pneumatic pump (S2) being disposed in fluid communication with the second chamber (34-2), and wherein the second pneumatic pump (S2) is independently controllable by the processor (20) to produce a neutral or positive pressure differential across a portion of the conveyor surface corresponding to the face-to-face interface to transfer sheet material from one conveyor module (12) to the other conveyor module (14).
2. The sheet handling apparatus according to Claim 1, wherein a negative pressure differential is developed across at least one of the conveyor surfaces (12C, 14C) to convey the sheet material along the feed path (FP).

3. The sheet handling apparatus according to Claim 2, wherein the pressure differential across the first conveyor surface is neutralized while a negative pressure differential is developed across the second conveyor surface to transfer the sheet material from the first to the second conveyor module. 5
4. The sheet handling apparatus according to Claim 3, wherein the pressure differential across the first conveyor surface (12C) is neutralized while a negative pressure differential is developed across the second conveyor surface (14C) to transfer the sheet material from the first to the second conveyor module along the face-to-face interface (FF). 10
5. The sheet handling apparatus according to any preceding claim, wherein the first and second conveyor surfaces define a substantially linear, coplanar feed path (FP) for transporting the sheet material. 15

Patentansprüche

1. Blatt-Handhabungsvorrichtung zum Transportieren von Blattmaterial längs einem Zufuhrpfad (FP), umfassend: 25
 - erste und zweite Fördermodule (12, 14) mit ersten bzw. zweiten Förderoberflächen (12C, 14C) zum Antreiben des Blattmaterials längs dem Zufuhrpfad, wobei die Fördermodule (12, 14) so ausgelegt sind, dass zumindest ein Teil der ersten Förderoberfläche (12C) zumindest einem Teil der zweiten Förderoberfläche (14C) längs einer Flächen-zu-Flächen-Schnittstelle (FF) gegenüberliegt; 30
 - ein Mittel (16) zum Entwickeln eines Druckdifferentials zwischen den ersten und zweiten Förderoberflächen (12C, 14C), um das Blattmaterial auf einer der Förderoberflächen zu halten und das Blattmaterial während des Transportes von der ersten zur zweiten Förderoberfläche zu transferieren; und 35
 - einen Prozessor (20), der operativ ist, unabhängig das Druckdifferentialmittel so zu steuern, dass Blattmaterial von einem Fördermodul (12) zum anderen Fördermodul (14) transferiert werden kann, indem das zwischen jeder der ersten und zweiten Förderoberflächen (12C, 14C) entwickelte Druckdifferential gesteuert wird, wenn das Blattmaterial zwischen der Flächen-zu-Flächen-Schnittstelle (FF) eingefügt ist, wobei die ersten und zweiten Förderoberflächen (12C, 14C) alle eine Mehrzahl von Öffnungen (12CO) darin enthalten, und wobei das mit jedem der ersten und zweiten Fördermodule assoziierte Druckdifferentialmittel erste und zweite pneumatische Pumpen (S1, S2) und einen, er-

ste und zweite Kammern (34-1, 34-2), die in Fluidkommunikation mit entsprechenden pneumatischen Pumpen (S1, S2) angeordnet sind, definierenden Raum beinhaltet, wobei jede Kammer weiterhin eine Seitenwandstruktur (30W) mit einer Mehrzahl von daran angrenzend an der entsprechenden Förderoberfläche (12C, 14C) angeordneten Öffnungen (30A) definiert, so dass Luft durch die Öffnungen (12CO) derselben und durch die Öffnungen (30A) des Raums (30) hindurchgehen können, um ein Druckdifferential an der Förderoberfläche zu erzeugen, wobei die erste pneumatische Pumpe (S1) in Fluidkommunikation mit der ersten Kammer (34-1) angeordnet ist und die zweite pneumatische Pumpe (S2) in Fluidkommunikation mit der zweiten Kammer (34-2) angeordnet ist, und wobei die zweite pneumatische Pumpe (S2) unabhängig durch den Prozessor (20) steuerbar ist, um ein neutrales oder positives Druckdifferential an einem Teil der Förderoberfläche zu erzeugen, das der Flächen-zu-Flächen-Schnittstelle entspricht, um Blattmaterial von einem Fördermodul (12) zum anderen Fördermodul (14) zu transferieren.

2. Blatthandhabungsvorrichtung gemäß Anspruch 1, wobei ein Negativ-Druckdifferential an zumindest einer der Förderoberflächen (12C, 14C) entwickelt wird, um das Blattmaterial längs dem Zufuhrpfad (FP) zu befördern. 40
3. Blatthandhabungsvorrichtung gemäß Anspruch 2, wobei das Druckdifferential an der ersten Förderoberfläche neutralisiert wird, während ein negatives Druckdifferential an der zweiten Förderoberfläche entwickelt wird, um das Blattmaterial von dem ersten zum zweiten Fördermodul zu transferieren. 45
4. Blatthandhabungsvorrichtung gemäß Anspruch 3, wobei das Druckdifferential an der ersten Förderoberfläche (12C) neutralisiert wird, während ein negatives Druckdifferential an der zweiten Förderoberfläche (14C) entwickelt wird, um das Blattmaterial vom ersten zum zweiten Fördermodul längs der Flächen-zu-Flächen-Schnittstelle (FF) zu transferieren. 50
5. Blatthandhabungsvorrichtung gemäß einem der vorstehenden Ansprüche, wobei die ersten und zweiten Förderoberflächen einen im Wesentlichen linearen, koplanaren Zufuhrpfad (FP) zum Transportieren des Blattmaterials definieren. 55

Revendications

1. Appareil (10) de manipulation de feuilles pour transporter un matériau en feuille le long d'un trajet (FP)

d'alimentation, comprenant, des premier et deuxième modules (12, 14) de transport ayant des première et deuxième surfaces (12C, 14C) de transport, respectivement, pour entraîner le matériau en feuille le long du trajet d'alimentation, les modules (12, 14) de transport étant agencés de sorte qu'au moins une partie de la première surface (12C) de transport s'oppose à au moins une partie de la deuxième surface (14C) de transport le long d'une interface en face-à-face (FF); un moyen (16) destiné au développement d'un différentiel de pression à travers les première et deuxième surfaces (12C, 14C) de transport pour maintenir le matériau en feuille sur l'une des surfaces de transport et transférer le matériau en feuille de la première à la deuxième surface de transport pendant le transport ; et un processeur (20) fonctionnant pour commander indépendamment un moyen de différentiel de pression de sorte que le matériau en feuille puisse être transféré d'un module (12) de transport à l'autre module (14) de transport en commandant le différentiel de pression développé à travers chacune des première et deuxième surfaces (12C, 14C) de transport lorsque le matériau en feuille est interposé entre l'interface en face-à-face (FF), dans lequel les première et deuxième surfaces (12C, 14C) de transport comportent chacune une pluralité d'ouvertures (12CO) dedans, et dans lequel le moyen de différentiel de pression associé à chacun des premier et deuxième modules de transport comporte des première et deuxième pompes (S1, S2) pneumatiques et un plénum (30) définissant des première et deuxième chambres (34-1, 34-2) agencées en communication par fluide avec des pompes (S1, S2) pneumatiques respectives, chaque chambre, en outre, définissant une structure (30W) de paroi latérale ayant une pluralité d'orifices (30A) disposés de manière adjacente à l'intérieur de la surface (12C, 14C) de transport respective de sorte que l'air puisse passer à travers les ouvertures de celle-ci et à travers les orifices (30A) du plénum pour produire un différentiel de pression à travers la surface de transport, la première pompe (S1) pneumatique étant disposée en communication par fluide avec la première chambre (34-1) et la deuxième pompe (S2) pneumatique étant disposée en communication par fluide avec la deuxième chambre (34-2), et dans lequel la deuxième pompe (S2) pneumatique est commandée indépendamment par le processeur (20) pour produire un différentiel de pression positif ou neutre à travers une partie de la surface de transport correspondant à l'interface en face-à-face pour transférer un matériau en feuille à partir d'un module (12) de transport à l'autre module (14) de transport.

2. Appareil de manipulation de feuilles selon la revendication 1, dans lequel un différentiel de pression

négatif est développé à travers l'au moins une des surfaces (12C, 14C) de transport pour transporter le matériau en feuille le long du trajet (FP) d'alimentation.

- 5
 - 10
 - 15
 - 20
 - 25
 - 30
 - 35
 - 40
 - 45
 - 50
 - 55
3. Appareil de manipulation de feuilles selon la revendication 2, dans lequel le différentiel de pression à travers la première surface de transport est neutralisé lorsqu'un différentiel de pression négatif est développé à travers la deuxième surface de transport pour transférer le matériau en feuille du premier au deuxième module de transport.
 4. Appareil de manipulation de feuilles selon la revendication 3, dans lequel le différentiel de pression à travers la première surface (12C) de transport est neutralisé lorsqu'un différentiel de pression négatif est développé à travers la deuxième surface de transport pour transférer le matériau en feuille du premier au deuxième module de transport le long de l'interface en face-à-face (FF).
 5. Appareil de manipulation de feuilles selon l'une quelconque des revendications précédentes, dans lequel les première et deuxième surfaces de transport définissent un trajet (FP) d'alimentation coplanaire essentiellement linéaire, pour transporter le matériau en feuille.

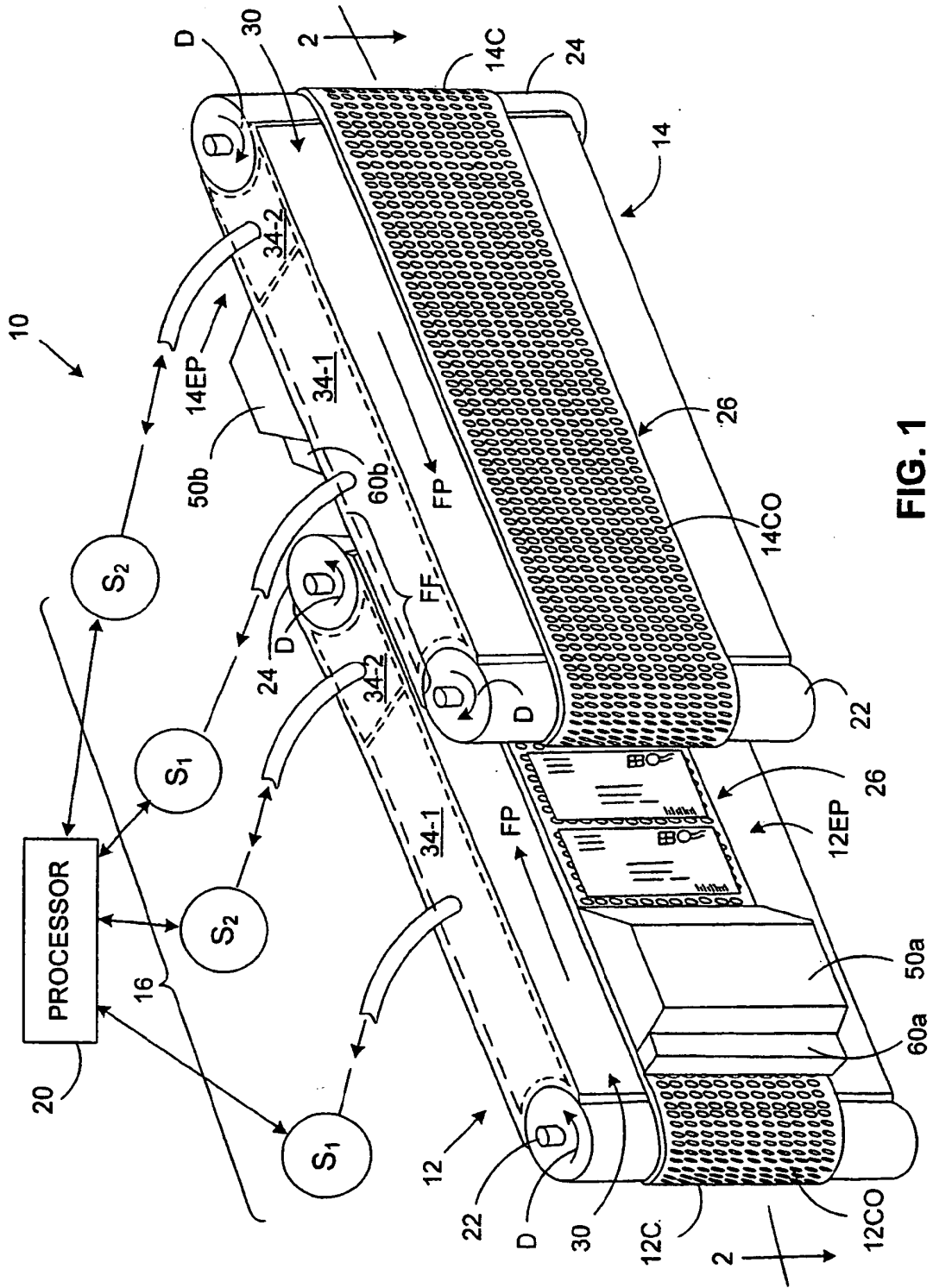

FIG. 1

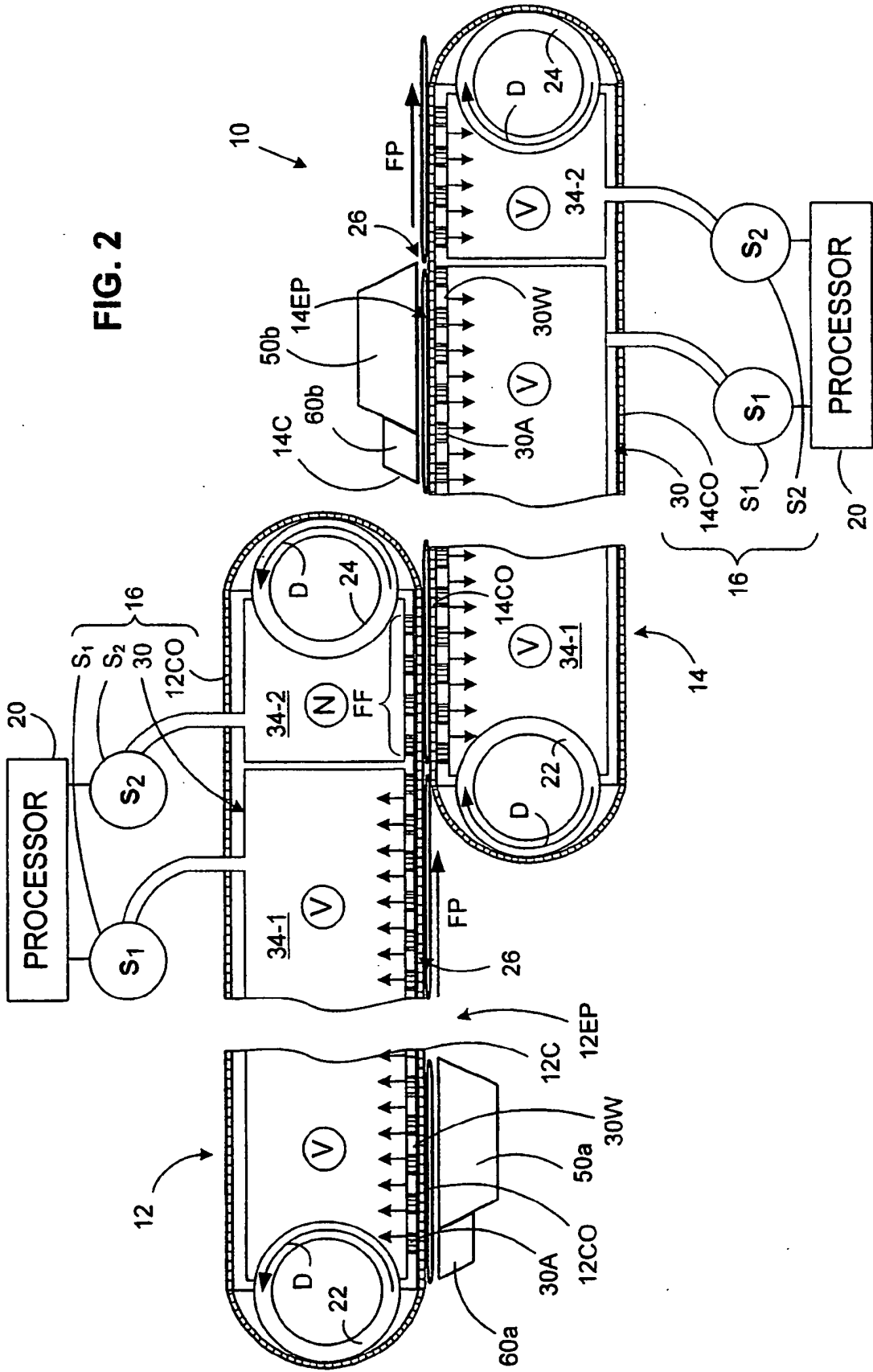

FIG. 3

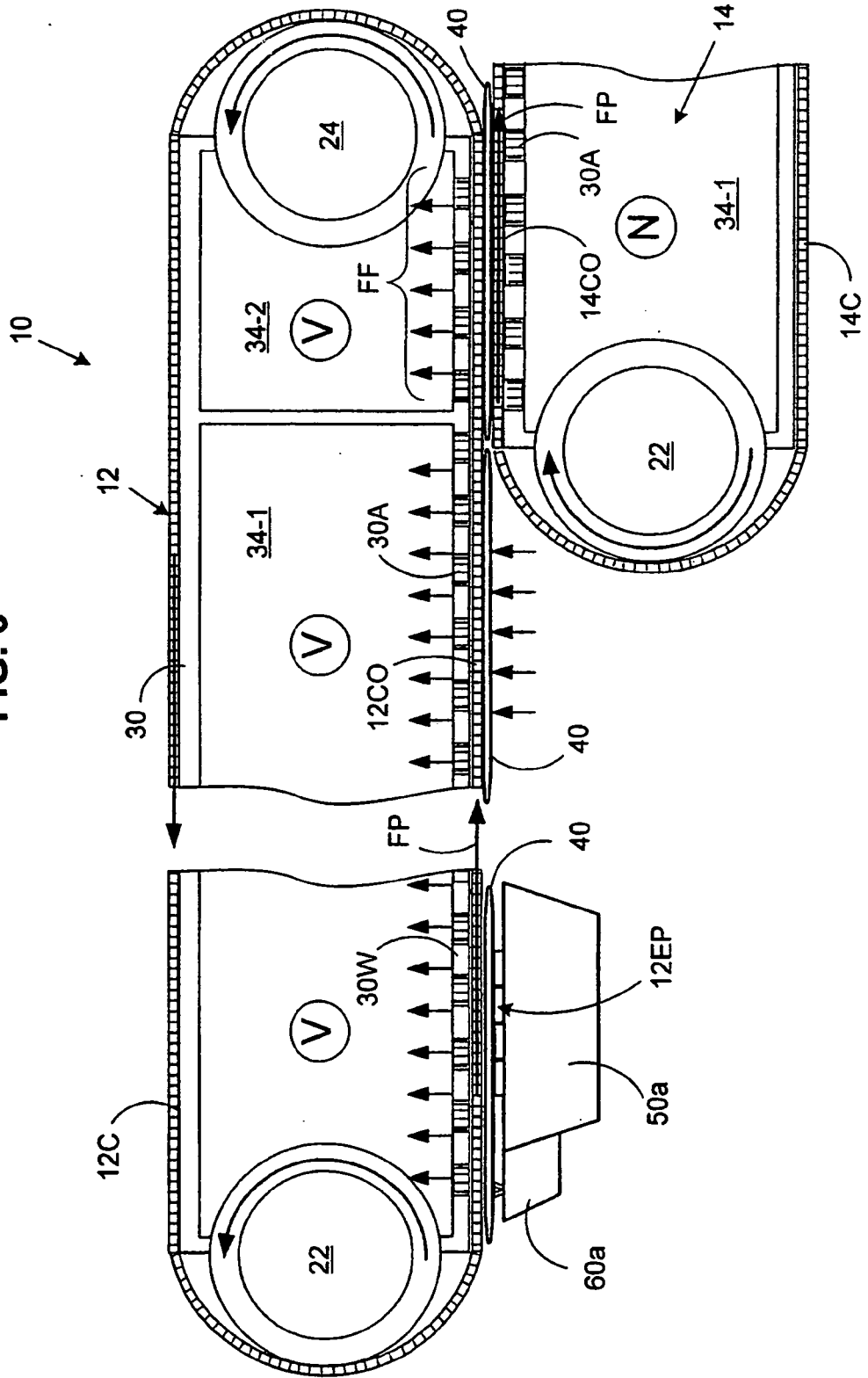

FIG. 4

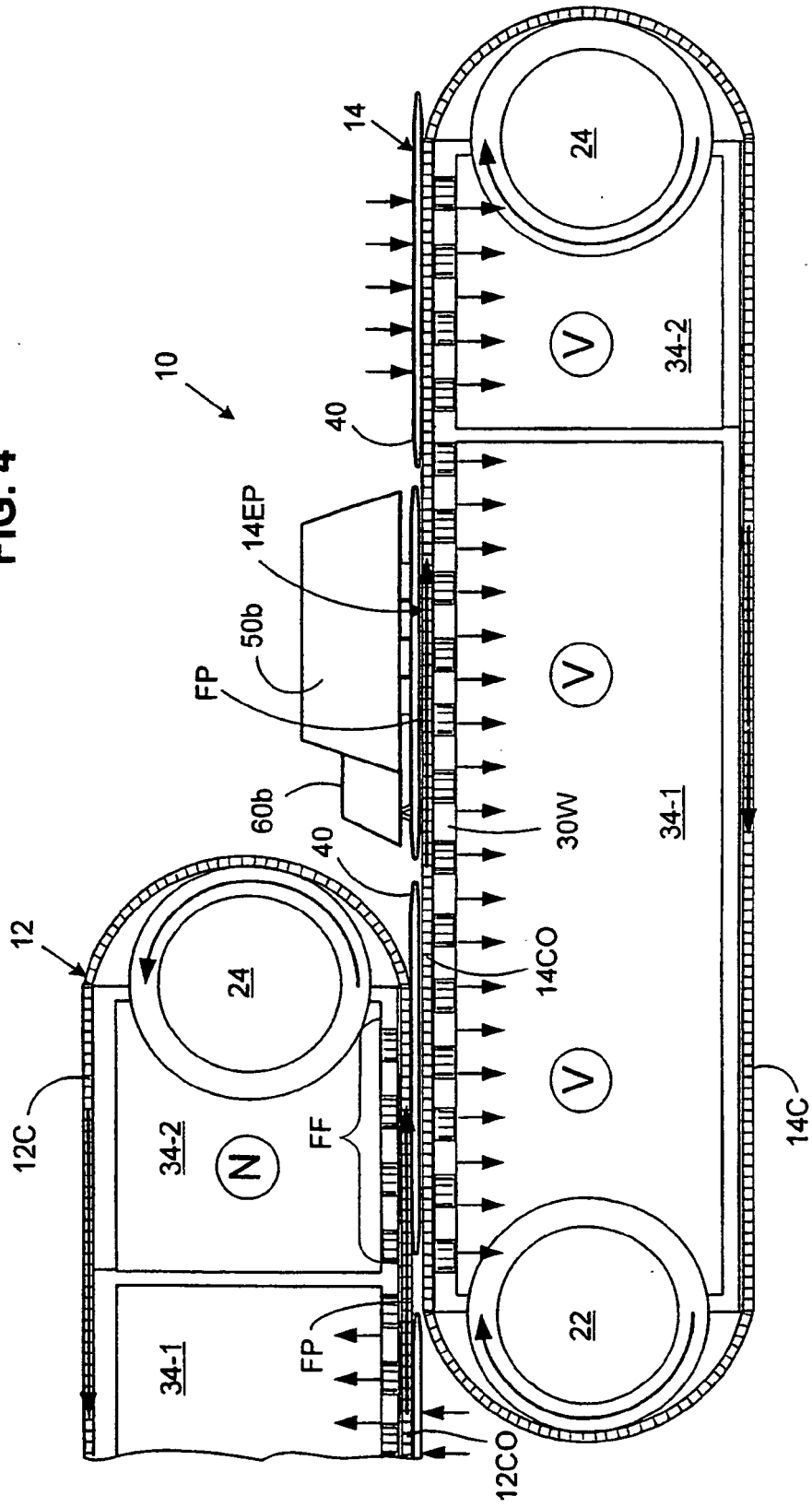
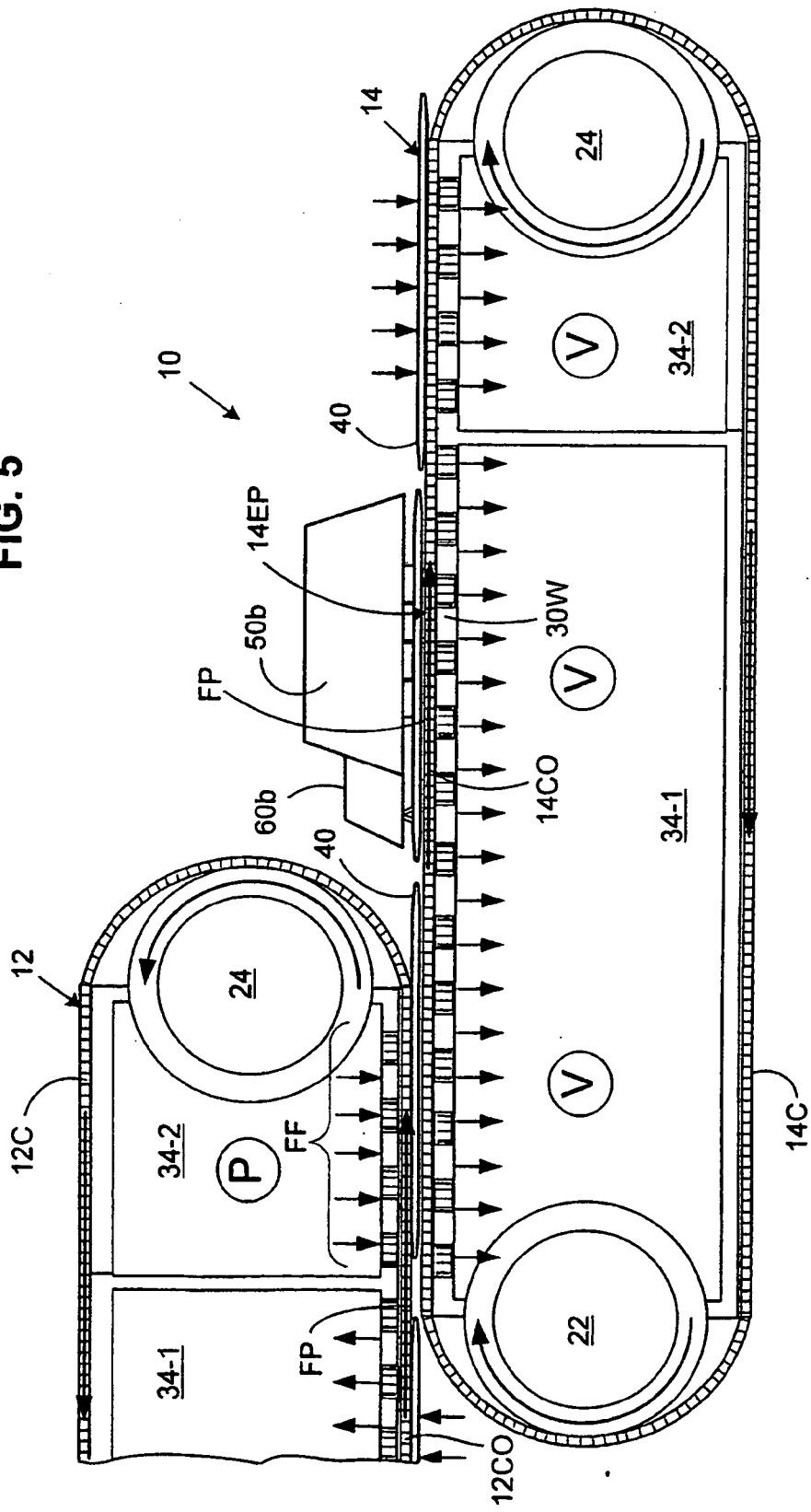

FIG. 5



REFERENCES CITED IN THE DESCRIPTION

This list of references cited by the applicant is for the reader's convenience only. It does not form part of the European patent document. Even though great care has been taken in compiling the references, errors or omissions cannot be excluded and the EPO disclaims all liability in this regard.

Patent documents cited in the description

- US 6139004 A [0003]