

No. 891,060.

PATENTED JUNE 16, 1908.

S. D. HAMMETT.
SPINNING FRAME ROLLER.
APPLICATION FILED NOV. 16, 1907.

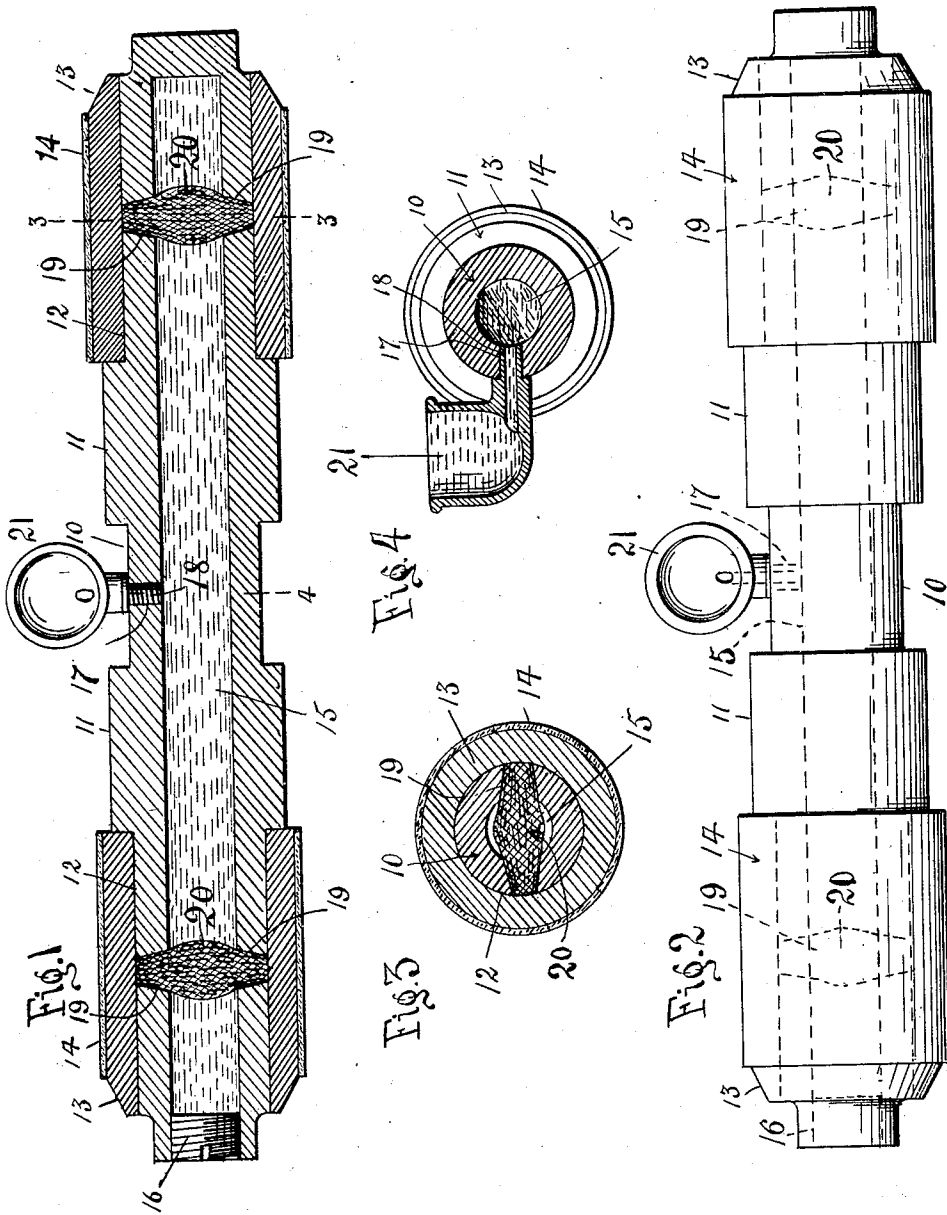

WITNESSES.
Wm. L. Edmister
C. H. Woodward

S. D. HAMMETT. INVENTOR
BY *Shelton & Brown* ATTYS.

UNITED STATES PATENT OFFICE.

SUMTER D. HAMMETT, OF ARLINGTON, SOUTH CAROLINA.

SPINNING-FRAME ROLLER.

No. 891,060.

Specification of Letters Patent.

Patented June 16, 1908.

Application filed November 16, 1907. Serial No. 402,495.

To all whom it may concern:

Be it known that I, SUMTER D. HAMMETT, a citizen of the United States, residing at Arlington, in the county of Spartanburg and State of South Carolina, have invented certain new and useful Improvements in Spinning-Frame Rollers, of which the following is a specification.

This invention relates to spinning frame rollers and similar devices, and has for its object to improve the construction and simplify the operation of applying lubricating material thereto.

With these and other objects in view, the invention consists in certain novel features of construction hereinafter shown and described and specifically pointed out in the claims, and in the drawings employed for illustrating the invention is shown the preferred form of embodiment of such invention, and in the drawings thus employed:—Figure 1 is a longitudinal sectional elevation of the improved device. Fig. 2 is a plan view. Fig. 3 is a transverse section on the line 3—3 of Fig. 1. Fig. 4 is a transverse section on the line 4—4 of Fig. 1.

The improved device comprises a body or stock 10, preferably in the form of a shaft having spaced enlargements 11—11 and with bearings 12—12 between the enlargements and the ends of the body, the bearings designed to receive the rollers represented at 13—13, the rollers being shown as covered with flexible material, such as leather, buckskin or the like of the usual texture and indicated at 14—14.

The body 10 is provided with a longitudinal bore 15 open at one end and with a screw plug 16 closing the open end, so that the interior of the bore is readily accessible throughout its whole length without disturbing the rollers 13—13.

Between the enlargements 11—11 a feed bore 17 is provided in one side of the body and communicating with the bore 15, and connected into this feed bore, preferably by a threaded stem 18, is an oil receiver or reservoir 21, the latter open at its upper end. By this simple means the bore 15 may be readily supplied with the lubricant, and by reason of the relatively large size of the member 21, a constant "head" of the lubricant is maintained to keep the reservoir 15 filled.

The body 10 is provided opposite to the bearings 12—12 with transverse apertures 19—19, the apertures communicating with

the bore 15, as shown. The side walls of the apertures 19 diverge inwardly so that the inner ends of the apertures or the ends next to the bore are the largest, as shown in Fig. 1.

Each opposite pair of apertures 19 is provided with a filling or wick of suitable absorbent material, such as cotton wool, "waste" or the like, as indicated at 20.

The "head" maintained by the receiver 21 insures a constant pressure upon the oil in the reservoir, and thus insures the requisite constant "flooding" of the wick members, and thereby facilitates their operation.

The bore 15 is designed to serve as a reservoir for lubricating material, and when filled with oil, a portion of the latter will be absorbed by the filling material 20 and slowly seep through the wick material and pass to the bearings 12—12, and keep the same uniformly lubricated. The natural action of the lubricant will swell the flexible wick material 20 and cause it to bulge somewhat within the reservoir, while the wick material will be compressed within the tapering apertures 19, so that the lubricant material will be retarded to a sufficient extent to prevent waste, and thus also prevent leakage of the lubricating material from the bearings. The bearings will thus be supplied with the lubricating material just as fast as it is required and no faster, so that all waste and leakage is effectually prevented. When the wick members 20 become worn out and require to be renewed, this can be very quickly and cheaply accomplished.

The apertures 19 being disposed opposite each other and with the ends of the wick within the apertures, the body of the wick is supported and the ends maintained in their compressed condition, and are therefore not liable to be shaken loose by the vibrations caused by the rapid rotation of the rollers.

The oppositely disposed apertures lie in a horizontal plane, consequently the wick also lies in a horizontal plane, and will not therefore be liable to be displaced by gravity. In the event of the reservoir 15 requiring to be cleaned, this can be very readily accomplished by removing the plug 16.

The device is very simple in construction, can be cheaply manufactured and applied, and operates effectually for the purposes described.

Having thus described the invention, what is claimed as new is:—

A device of the class described comprising

a hollow stock having spaced external bearings and with transverse apertures providing communication between the interior of the stock and the bearings, the walls of the apertures diverging toward the interior of the stock, and fillers of absorbent material extending between said apertures with the ends thereof compressed and disposed within the apertures, whereby the lubricant is retarded

in its passage through the filler elements and said filler elements maintained in position in the stock. 10

In testimony whereof I affix my signature in presence of two witnesses.

SUMTER D. HAMMETT.

Witnesses:

JOHN C. CALBERT,
BRUCE SMITH.