

(No Model.)

2 Sheets—Sheet 1.

C. HOFFMANN.

APPARATUS FOR PUTTING ELECTRIC MOTORS INTO CIRCUIT.

No. 526,810.

Patented Oct. 2, 1894.

Fig. 1.

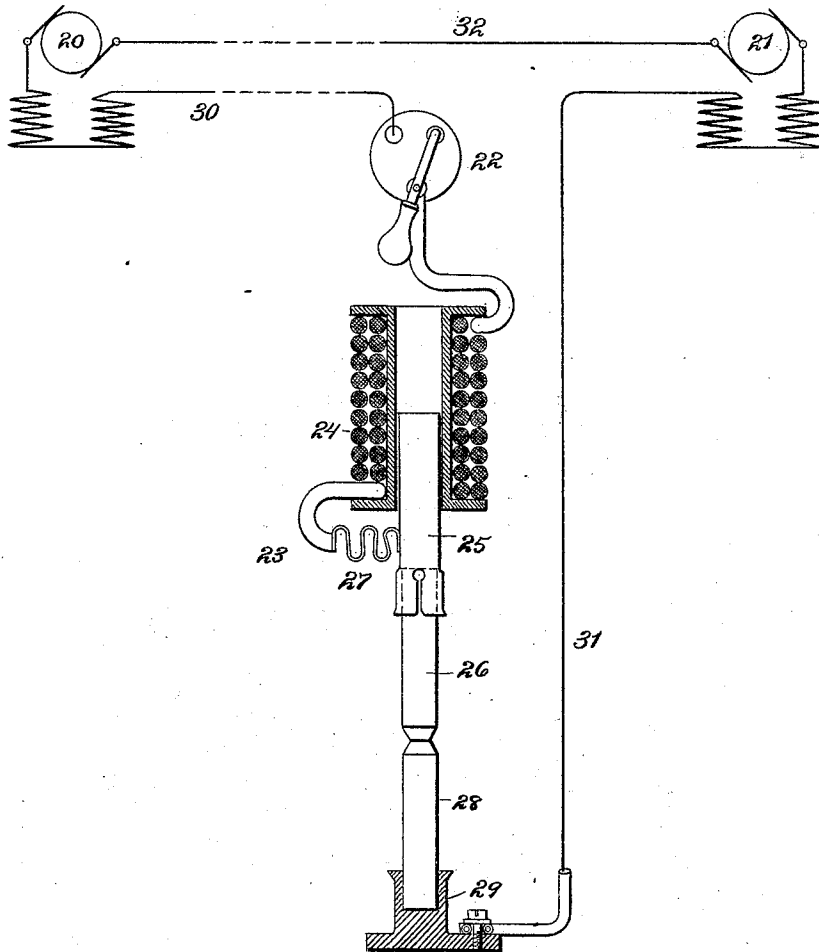

WITNESSES:

Williamson
Timothy F. Dillard

INVENTOR

Carl Hoffmann
BY
Geo. H. Benjamin
ATTORNEY.

C. HOFFMANN.

APPARATUS FOR PUTTING ELECTRIC MOTORS INTO CIRCUIT.

No. 526,810.

Patented Oct. 2, 1894.

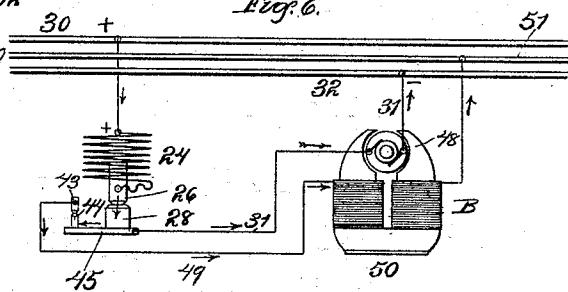
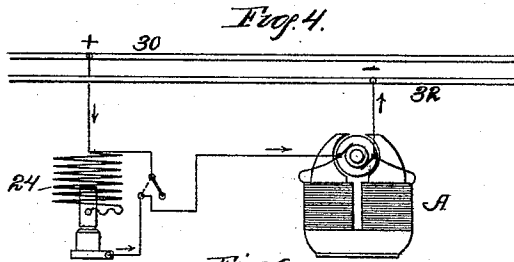
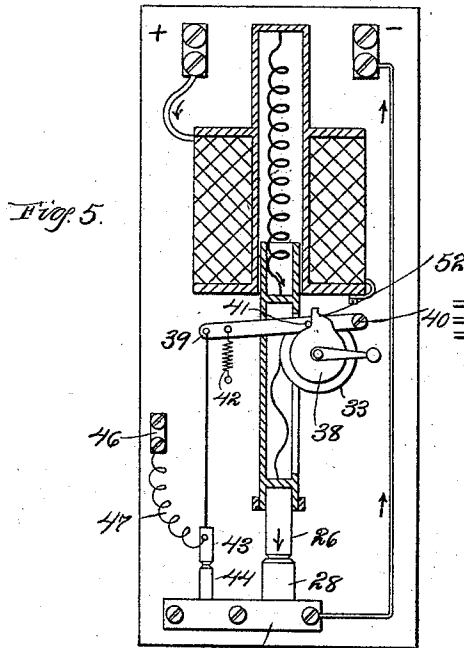
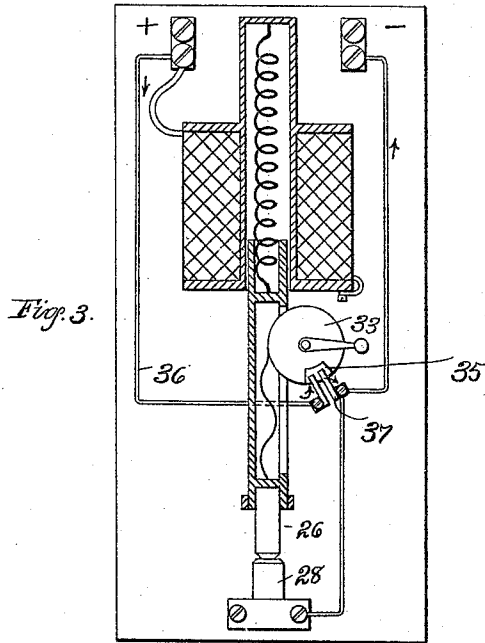
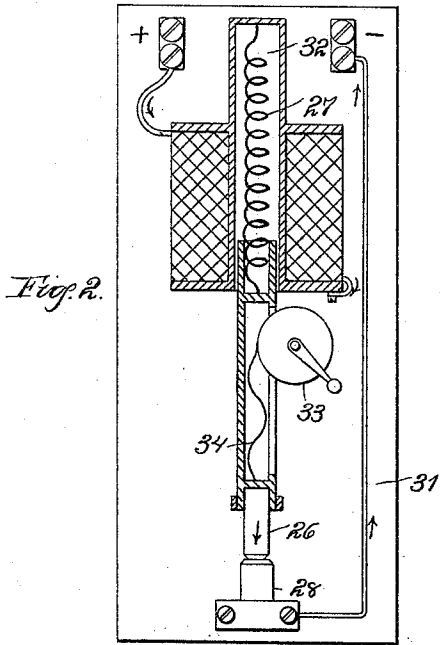

WITNESSES: 45

*William A. ...
Timothy ...*

INVENTOR

Carl Hoffmann

BY

Geo. H. Benjamin
ATTORNEY

UNITED STATES PATENT OFFICE.

CARL HOFFMANN, OF CHARLOTTENBURG, ASSIGNOR TO SIEMENS & HALSKE,
OF BERLIN, GERMANY.

APPARATUS FOR PUTTING ELECTRIC MOTORS INTO CIRCUIT.

SPECIFICATION forming part of Letters Patent No. 526,810, dated October 2, 1894.

Application filed October 29, 1892. Serial No. 450,342. (No model.) Patented in Belgium August 16, 1892, No. 100,765; in Italy September 23, 1892, No. 32,443; in France November 8, 1892, No. 223,298; in Austria-Hungary November 18, 1892, No. 38,698 and No. 69,457; in Switzerland November 30, 1892, No. 5,483; in Germany January 7, 1893, No. 66,622; in Norway February 3, 1893, No. 2,882; in Sweden June 20, 1893, No. 4,461, and in England July 10, 1893, No. 14,647.

To all whom it may concern:

Be it known that I, CARL HOFFMANN, a subject of the King of Prussia and German Emperor, residing at the city of Charlottenburg, in the Kingdom of Prussia and German Empire, have invented new and useful Improvements in an Apparatus for Putting Electric Motors into Circuit, (for which I have obtained Letters Patent in Germany, No. 66,622, dated January 7, 1893; in France, No. 223,298, dated November 8, 1892; in Belgium, No. 100,765, dated August 16, 1892; in Italy, No. 32,443, dated September 23, 1892; in Switzerland, No. 5,483, dated November 30, 1892; in Norway, No. 2,882, dated February 3, 1893; in Sweden, No. 4,461, dated June 20, 1893; in England, No. 14,647, dated July 10, 1893, and in Austria-Hungary, No. 38,698 and No. 69,457, dated November 18, 1892,) of which the following is a specification.

My invention relates to a method of and apparatus for regulating the current transmitted to electro-motors or similar apparatus.

In putting electro-motors or similar apparatus into circuit with a source of electrical energy, it is usual to modify the current transmitted, by means of resistance in the form of wire coils or other apparatus which will permit but a portion of the current to be constantly transmitted, and which resistance is gradually removed as the motor obtains its normal speed, or when no longer required. This practice is objectionable for commercial and practical reasons, and I have therefore devised a method of and apparatus for transmitting and modifying the current which does not entail the employment of resistance, as such, but only such electrical resistance as is consequent upon the operation of the regulating apparatus.

In the accompanying drawings which illustrate my invention, similar figures of reference indicate like parts.

Figure 1 is diagrammatic in character and illustrates my improved regulating apparatus, coupled in circuit with an electric generator and motor. Fig. 2 is an elevation and vertical section showing one form in which

my improved apparatus may be made. Fig. 3 is a similar view showing my apparatus provided with a shunt around the device. Fig. 4 is a diagram showing how Figs. 2 and 3 may be coupled in circuit with the motor. Fig. 5 is a modified construction of Fig. 2 specially adapted for use in three-wire systems. Fig. 6 is a diagram showing how the apparatus of Fig. 5 may be coupled in circuit with a constant current motor in a three-wire system.

Referring first to Fig. 1: 20 denotes the generator; 21, an electro-motor; 22, a circuit switch; 23, my improved regulating device. As shown in the several figures, this device consists of an electro-magnet 24, provided with an armature 25, which carries a heavy carbon 26. The armature 25 of the magnet is connected to the magnet coil by means of the conductor 27.

28 is a carbon supported in a holder 29. The carbon 26 and the armature 25, as in the case of an electric arc lamp, are suspended so as to freely move in the magnet 24, while the carbon 28 is stationary. The current from the generator is led through the conductor 30 to the switch 22, from thence to the coil of the magnet 24; to the armature 25, carbon 26, and from it to carbon 28, to holder 29, by conductor 31 to motor 21, and by conductor 32 back to the generator.

The mode of operation of my improved regulator is as follows: As soon as the switch 22 is closed, a current which is greater than that normally used for operating a motor, is transmitted to the magnet 24, in consequence of which the magnet attracts its armature and lifts the carbon 26 from contact with the carbon 28. Before this can take place, however, a current impulse has been transmitted to the motor 21, and this impulse acts to set the motor in motion. When the magnet 24 attracts its armature, the current through the apparatus is interrupted, the magnet allows its armature to fall, and the carbons 26 and 28 are again brought into contact, a new impulse is transmitted to the motor, and the magnet again attracts its armature and separates the

carbons from each other. This action of the magnet, *i. e.*, allowing the carbons to come into contact and then separating them, is repeated until the motor has obtained, approximately, 5 its normal speed and thus generates a sufficient counter electro-motive force to cut down the current transmitted from the generator to the normal current used in the motor. When this point is reached, the magnet 24 is not sufficiently magnetized to enable it to separate 10 the carbons 26 and 28.

Instead of adapting the magnet 24 to entirely separate the carbons when the current is first turned on, approximately the same object will be attained if the carbons are only so far separated as to permit a considerable arc to be formed between them,—which separation should be sufficient to bring about the desired modification in the transmitted current. 15 When this latter scheme is adopted, the length of the arc will decrease as the counter electro-motive force from the motor is increased, until the point is reached where the motor is generating its maximum counter electro-motive 20 force, when the two carbons will be in contact.

Referring to Fig. 2, the conductor 27 is shown as arranged within the guiding tube 32 of the armature and there is provided also a small wheel 33 which is connected to the armature by means of a flexible connection 34. 25 By rotating the wheel 33, the carbon 26 will be lifted and the circuit broken.

In Fig. 3, the small wheel 33 is shown provided with a contact plate 35. 36 is a shunt conductor connected to the binding posts of the apparatus and to the contact strips 37. 30 When the wheel 33 is in the position shown, the current may be shunted around the apparatus.

Figs. 5 and 6 show a special arrangement for the three-wire system. In this construction, the small wheel 33 is provided with a cam 38. 39 is a lever, pivoted at 40, on which is a small pin 41, which travels over the periphery 45 of the cam. 42 is a helical spring which tends to draw the lever 39 to the position shown in the figure. Connected to the end of the lever, through a rod, is a small carbon 43, and placed below it, is another carbon 44, which is mounted on the same plate 45, in electrical 50 connection with the carbon 28. The carbon 43 is connected with the binding post 46 by the conductor 47.

In the diagram, Fig. 6, the circuit is arranged as follows: The current from the generator passes along the conductor 30 to the magnet 24, by carbon 26 to carbon 28. Here the current divides, one part passing through 55 conductor 31 to armature of motor 48, thence by conductor 31 to conductor 32, to the negative pole of the generator. The other part of the current passes by plate 45, carbon 44 to carbon 43, by conductor 49 to field magnets 60 50 of the motor, to the neutral conductor 51 of the three-wire system. The object of this arrangement is to provide for a lower tension in the field magnets of the motor than is

present in the armature of the motor. By reason of the shape of the cam 38 upon the wheel 33, the two small carbons 43 and 44 70 may be brought into contact, and the field magnets of the motor put into circuit before the carbons 26 and 28 are brought into apposition, and the impulse or current transmitted to the armature, and conversely, the field 75 magnets may be cut out of circuit after the current is transmitted to the armature.

In rotating the wheel 33, if the portion 52 of the cam plays under the pin 41, the carbon 43 will be lifted and the circuit through 80 the field magnets broken. With the cam in the position shown in the figure, the circuit through the field magnets is made.

I wish it understood that I do not limit myself to the precise construction, or the manner of putting in circuit of the regulating device described and shown in the drawings, as many changes may be made therein, and in its application to a system, without departing from the intent of my invention. 90

I claim as my invention—

1. The herein-described method of regulating the current from a generator to an electro motor within normal working limits, which consists in automatically and simultaneously 95 varying the resistance of the circuit in inverse proportion to the counter electro motive force of the motor.

2. The herein-described method of regulating the current from a generator of electricity to an electro motor within normal working limits, which consists in maintaining a uniform balance between the counter electro motive force of the motor and the resistance 100 of a variable arc.

3. The herein-described method of regulating current from a generator to an electro-motor within normal working limits, which consists in automatically forming and springing an arc controlling the circuit through the motor, thereby modifying the transmitted current in proportion to the requirements of the motor; and subsequently maintaining a uniform balance between the resistance of said arc and the counter-electromotive force 105 of the motor until the normal speed is attained.

4. The herein-described method of regulating the current from a generator to an electro motor within normal working limits, which 120 consists in interposing between the generator and the electro motor an electric arc and controlling the resistance of said arc by the counter electro motive force of the motor.

5. The combination with a generator and an electro motor, of means interposed in circuit between the two for creating a variable arc whereby the current transmitted to the motor may be varied within normal working limits simultaneously with and in inverse proportion to the resistance of the arc. 130

6. The combination with a generator and an electro motor, of means interposed in circuit between the two for automatically rupt-

uring the circuit and creating an arc of variable resistance whereby the current transmitted may be automatically cut off or gradually varied within normal working limits as the arc is broken or its resistance increased.

5 7. The combination with a generator and an electro-motor, of means interposed in a three-wire system between the two for first transmitting a portion of the current through the field magnets of said motor, later a portion of said current through the armature of said motor, and subsequently automatically varying the currents so transmitted, in proportion to the counter electro-motive force
15 from the motor.

8. In an electrical regulating device, the combination of a magnet, an armature adapted to be attracted thereby, a carbon carried by said armature, a normally open shunt
20 circuit around said magnet, and means for simultaneously raising said armature and making circuit through said shunt.

9. In an electrical regulating device for a three-wire system, the combination of a magnet, an armature adapted to be attracted
25 thereby, a carbon carried thereby, a fixed opposing carbon, a shunt around the said magnet, and means for simultaneously raising said armature and striking an arc between
30 said carbons, and subsequently opening the shunt.

10. The combination with a generator, an electro motor and a circuit connecting the two, of a magnet included in the circuit, a reciprocating armature therefor, a carbon
35 forming a continuation of said armature and a second fixed carbon in apposition to said first carbon as set forth.

11. The method of operating motors in circuit with a source of energy which consists
40 in first transmitting current to the field magnets through a pair of opposed carbons in circuit with said magnet, subsequently transmitting a current to the armature through a pair of opposed carbons in circuit therewith,
45 then separating the carbons in circuit with the field to cut out the field and finally separating the carbons in circuit with the armature to regulate the current supplied thereto.

12. The method of removing an electro motor from circuit with a suitable source of electricity, which consists in removing the field
50 magnets from the circuit, subsequently introducing resistance into the circuit including the armature, and finally cutting said armature out of circuit, as set forth.
55

In testimony whereof I have affixed my signature in the presence of two witnesses.

CARL HOFFMANN.

Witnesses:

GUSTAV STENZEL,
MAX WAGNER.