

(19) World Intellectual Property Organization  
International Bureau



(43) International Publication Date  
22 April 2004 (22.04.2004)

PCT

(10) International Publication Number  
WO 2004/033728 A3

(51) International Patent Classification<sup>7</sup>: C12Q 1/68

(21) International Application Number:  
PCT/NL2003/000690

(22) International Filing Date: 13 October 2003 (13.10.2003)

(25) Filing Language: English

(26) Publication Language: English

(30) Priority Data:  
60/417,779 11 October 2002 (11.10.2002) US

(71) Applicants (for all designated States except US): ERASMUS UNIVERSITEIT ROTTERDAM [NL/NL]; Dr. Molewaterplein 50, NL-3015 GE Rotterdam (NL). DAVI, Frederic, Bernard, Louis [FR/FR]; 7 Chemin de l'Ermitage, F-92130 Meudon (FR).

(72) Inventors; and

(75) Inventors/Applicants (for US only): VAN DONGEN, Jacobus, Johannes, Maria [NL/NL]; Parallelweg Zuid 147, NL-2914 LE Nieuwerkerk aan de IJssel (NL). LANGERAK, Anthonie, Willem [NL/NL]; van

Bronkhorstvljet 34, NL-2992 WJ Barendrecht (NL). SCHUURING, Eduardus, Maria, Dominicus [NL/NL]; Eckhartstraat 54, NL-9746 BM Groningen (NL). SAN MIQUEL, Jesus, Fernando [ES/ES]; Calle Mizar 16, Urbanizacion Aldebaran, Santa Marta de Tormes, 37900 Salamanca (ES). GARZIA SANZ, Ramon [ES/ES]; Servicio de Hematologia, Avenida de Mirat 9 5-B, 37005 Salamanca (ES). PARREIRA, Antonio [PT/PT]; Rue Eca de Queroz 17-1, 1050-095 Lissabon (PT). SMITH, John, Lewis [AU/GB]; Cobweb Cottage, North Common Lane, Landford, Wiltshire SP5 2EL (GB). LAVENDER, Frances, Louise [GB/GB]; White Copse, 16, Honey Lane, Burley, Ringwood, Hampshire BH24 4EN (GB). MORGAN, Gareth, John [GB/GB]; 18 Gledhow Wood Grove, Roundhay, Leeds, Yorkshire LS8 1NZ (GB). EVANS, Paul, Anthony, Stuart [GB/GB]; Pinfold Cottage, Caudle Hill, Fairburn, Yorkshire WF 11 9JR (GB). KNEBA, Michael [DE/DE]; Am See 4, 24259 Westensee (DE). HUMMEL, Michael [DE/DE]; Kaiserstrasse 4, 12105 Berlin (DE). MACINTYRE, Elizabeth, Anne [GB/FR]; 7 Chemin de l'Ermitage, F-92130 Meudon (FR). BASTARD, Christian [FR/FR]; 4 rue des Bouleaux, F-76680 Ardouval (FR).

(74) Agent: PRINS, A.W.; Nieuwe Parklaan 97, NL-2587 BN Den Haag (NL).

[Continued on next page]

(54) Title: NUCLEIC ACID AMPLIFICATION PRIMERS FOR PCR-BASED CLONALITY STUDIES

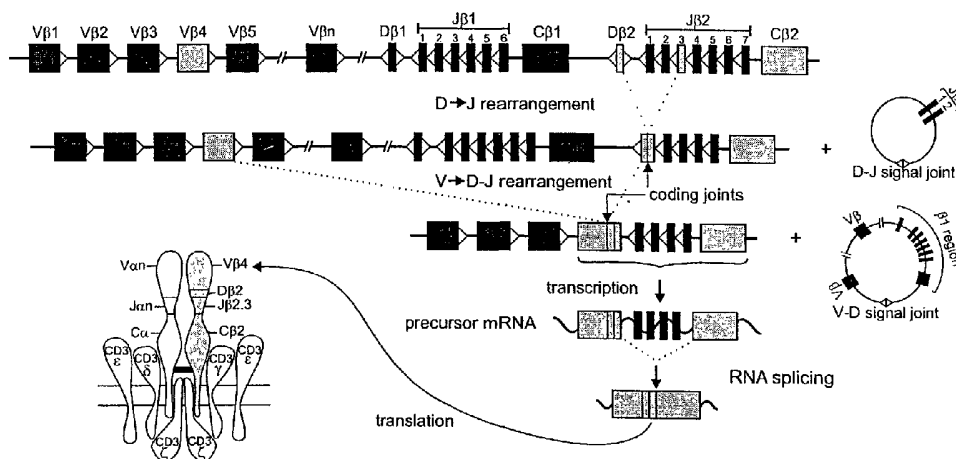

(57) Abstract: The invention relates to PCR-based clonality studies for among others early diagnosis of lymphoproliferative disorders. Provided is a set of nucleic acid amplification primers comprising a forward primer, or a variant thereof, and a reverse primer, or a variant thereof, capable of amplifying a rearrangement selected from the group consisting of a VH-JH IGH rearrangement, a DH-JH IGH rearrangement, a VK-JK IGH rearrangement, a VK/intron-Kde IGH rearrangement, a VL-JL IGL rearrangement, a VB-JB TCRB rearrangement, a DB-JB TCRB rearrangement, a Vγ-Jγ TCRG rearrangement, a Vδ-Jδ TCRD rearrangement, a Dδ-Dδ TCRD rearrangement, a Dδ-Jδ TCRD rearrangement, a Vδ-Dδ TCRD rearrangement, or a translocation selected from t(11;14)(BCL1-IGH) and t(14;18)(BCL2-IGH). The primers can be used in PCR-based clonality studies for early diagnosis of lymphoproliferative disorders and detection of minimal residual disease (MRD). Also provided is a kit comprising at least one set of primers of the invention.

WO 2004/033728 A3



(81) **Designated States (national):** AE, AG, AL, AM, AT (utility model), AT, AU, AZ, BA, BB, BG, BR, BY, BZ, CA, CH, CN, CO, CR, CU, CZ (utility model), CZ, DE (utility model), DE, DK (utility model), DK, DM, DZ, EC, EE (utility model), EE, EG, ES, FI (utility model), FI, GB, GD, GE, GH, GM, HR, HU, ID, IL, IN, IS, JP, KE, KG, KP, KR, KZ, LC, LK, LR, LS, LT, LU, LV, MA, MD, MG, MK, MN, MW, MX, MZ, NI, NO, NZ, OM, PG, PH, PL, PT, RO, RU, SC, SD, SE, SG, SK (utility model), SK, SL, SY, TJ, TM, TN, TR, TT, TZ, UA, UG, US, UZ, VC, VN, YU, ZA, ZM, ZW.

(84) **Designated States (regional):** ARIPO patent (GH, GM, KE, LS, MW, MZ, SD, SL, SZ, TZ, UG, ZM, ZW), Eurasian patent (AM, AZ, BY, KG, KZ, MD, RU, TJ, TM), European patent (AT, BE, BG, CH, CY, CZ, DE, DK, EE,

ES, FI, FR, GB, GR, HU, IE, IT, LU, MC, NL, PT, RO, SE, SI, SK, TR), OAPI patent (BF, BJ, CF, CG, CI, CM, GA, GN, GQ, GW, ML, MR, NE, SN, TD, TG).

**Published:**

- *with international search report*
- *before the expiration of the time limit for amending the claims and to be republished in the event of receipt of amendments*

**(88) Date of publication of the international search report:**

12 August 2004

*For two-letter codes and other abbreviations, refer to the "Guidance Notes on Codes and Abbreviations" appearing at the beginning of each regular issue of the PCT Gazette.*

# INTERNATIONAL SEARCH REPORT

International Application No

/NL 03/00690

**A. CLASSIFICATION OF SUBJECT MATTER**  
IPC 7 C12Q1/68

According to International Patent Classification (IPC) or to both national classification and IPC

**B. FIELDS SEARCHED**

Minimum documentation searched (classification system followed by classification symbols)

IPC 7 C12Q C07K

Documentation searched other than minimum documentation to the extent that such documents are included in the fields searched

Electronic data base consulted during the international search (name of data base and, where practical, search terms used)

EPO-Internal, WPI Data, PAJ, EMBASE, BIOSIS, Sequence Search

**C. DOCUMENTS CONSIDERED TO BE RELEVANT**

Category °	Citation of document, with indication, where appropriate, of the relevant passages	Relevant to claim No.
X	WO 02/00848 A (BUSCH CHRISTER ;ASCENDIA AB (SE); LUNDIN TOMAS (SE); MAANSSON PER) 3 January 2002 (2002-01-03) example 1	1, 20, 21, 37-42
Y	US 6 312 690 B1 (EDELMAN L EACUTE NA ET AL) 6 November 2001 (2001-11-06) column 7	1, 20, 21, 37-42
Y	US 5 472 693 A (MEZES PETER S ET AL) 5 December 1995 (1995-12-05) SEQ ID NO.23	1, 20, 21, 37-42
	----- -/--	

Further documents are listed in the continuation of box C.

Patent family members are listed in annex.

° Special categories of cited documents :

- \*A\* document defining the general state of the art which is not considered to be of particular relevance
- \*E\* earlier document but published on or after the international filing date
- \*L\* document which may throw doubts on priority claim(s) or which is cited to establish the publication date of another citation or other special reason (as specified)
- \*O\* document referring to an oral disclosure, use, exhibition or other means
- \*P\* document published prior to the international filing date but later than the priority date claimed

- \*T\* later document published after the international filing date or priority date and not in conflict with the application but cited to understand the principle or theory underlying the invention
- \*X\* document of particular relevance; the claimed invention cannot be considered novel or cannot be considered to involve an inventive step when the document is taken alone
- \*Y\* document of particular relevance; the claimed invention cannot be considered to involve an inventive step when the document is combined with one or more other such documents, such combination being obvious to a person skilled in the art.
- \*Z\* document member of the same patent family

Date of the actual completion of the international search

3 March 2004

Date of mailing of the international search report

16. 06. 2004

Name and mailing address of the ISA

European Patent Office, P.B. 5818 Patentlaan 2  
NL - 2260 HV Rijswijk  
Tel. (+31-70) 340-2040, Tx. 31 651 epo nl,  
Fax: (+31-70) 340-3016

Authorized officer

Knudsen, H

## INTERNATIONAL SEARCH REPORT

ational Application No

/NL 03/00690

C.(Continuation) DOCUMENTS CONSIDERED TO BE RELEVANT		
Category °	Citation of document, with indication, where appropriate, of the relevant passages	Relevant to claim No.
Y	DEANE M ET AL: "IMMUNOGLOBULIN GENE FINGERPRINTING AN APPROACH TO ANALYSIS OF B LYMPHOID CLONALITY IN LYMPHOPROLIFERATIVE DISORDERS" BRITISH JOURNAL OF HAEMATOLOGY, vol. 77, no. 3, 1991, pages 274-281, XP009026476 ISSN: 0007-1048 abstract; table 1	1,20,21, 37-42
Y	WO 00/22111 A (MEDICAL RES COUNCIL ;CUMBERS SARAH JANE (GB); NEUBERGER MICHAEL SA) 20 April 2000 (2000-04-20) example 1	1,20,21, 37-42
A	BARKER R L ET AL: "CYTOMETRIC DETECTION OF DNA AMPLIFIED WITH FLUORESCENT PRIMERS: APPLICATIONS TO ANALYSIS OF CLONAL BCL-2 AND IGH GENE REARRANGEMENTS IN MALIGNANT LYMPHOMAS" BLOOD, W.B. SAUNDERS, PHILADELPHIA, VA, US, vol. 83, no. 4, 15 February 1994 (1994-02-15), pages 1079-1085, XP002923853 ISSN: 0006-4971 the whole document	1,20,21, 37-42
A	WO 00/28086 A (IVS TECHNOLOGIES LLC ;MILLER JEFFREY E W (US)) 18 May 2000 (2000-05-18) page 22; figure 1B	1,20,21, 37-42

# INTERNATIONAL SEARCH REPORT

International application No.  
PCT/NL 03/00690

## Box I Observations where certain claims were found unsearchable (Continuation of item 1 of first sheet)

This International Search Report has not been established in respect of certain claims under Article 17(2)(a) for the following reasons:

1.  Claims Nos.:  
because they relate to subject matter not required to be searched by this Authority, namely:
  
2.  Claims Nos.:  
because they relate to parts of the International Application that do not comply with the prescribed requirements to such an extent that no meaningful International Search can be carried out, specifically:
  
3.  Claims Nos.:  
because they are dependent claims and are not drafted in accordance with the second and third sentences of Rule 6.4(a).

## Box II Observations where unity of invention is lacking (Continuation of item 2 of first sheet)

This International Searching Authority found multiple inventions in this international application, as follows:

see additional sheet

1.  As all required additional search fees were timely paid by the applicant, this International Search Report covers all searchable claims.
  
2.  As all searchable claims could be searched without effort justifying an additional fee, this Authority did not invite payment of any additional fee.
  
3.  As only some of the required additional search fees were timely paid by the applicant, this International Search Report covers only those claims for which fees were paid, specifically claims Nos.:
  
4.  No required additional search fees were timely paid by the applicant. Consequently, this International Search Report is restricted to the invention first mentioned in the claims; it is covered by claims Nos.:  
  
1, 20, 21, 37-42 (partially)

### Remark on Protest

- The additional search fees were accompanied by the applicant's protest.
- No protest accompanied the payment of additional search fees.

FURTHER INFORMATION CONTINUED FROM PCT/ISA/ 210

This International Searching Authority found multiple (groups of) inventions in this international application, as follows:

Invention 1: claims 1,20,21,37-42 (partially)

A set of primers comprising primers binding to FR1 and one primer binding to JH (tube A in Fig.3B). Method and kit for use in amplification and detection of rearrangements.

Invention 2: claims 1,20,21,37-42 (partially)

A set of primers comprising a forward primer binding to FR2 and a reverse primer binding to JH (tube B in Fig 3B). Method and kit for use in amplification and detection of rearrangements.

Invention 3: claims 1,20,21,37-42 (partially)

A set of primers comprising a forward primer binding to FR3 and a reverse primer binding to JH (tube C in Fig 3B). Method and kit for use in amplification and detection of rearrangements.

Invention 4: claims 2,22 (completely), 20,37-42 (partially)

A set of primers wherein the forward primer is selected from DH primers and the reverse primer is the JH conservative primer shown in Fig 4A. Method and kit for use in amplification and detection of rearrangements.

Invention 5: claims 3-4,23-24 (completely), 20,37-42 (partially)

A set of primers wherein the forward primer is selected from V $\kappa$  or INTR primers and the reverse primer is a J $\kappa$  primer shown in Fig 5B. Method and kit for use in amplification and detection of rearrangements.

Invention 6: claims 5,25 (completely), 20,37-42 (partially)

A set of primers wherein the forward primer is selected from the V $\lambda$  primers shown in Fig.6B and the reverse primer is the J $\lambda$  primer shown in Fig.6B. Method and kit for use in amplification and detection of rearrangements.

Invention 7: claims 6,20,26,37-42 (partially)

A set of primers comprising a forward primer binding to V 2 and a reverse primer selected from the J A and J B primers shown in Fig 7B. Method and kit for use in amplification and detection of rearrangements.

---

Invention 8: claims 6,20,26,37-42 (partially)

A set of primers comprising a forward primer binding to V 4 and a reverse primer selected from the J A and J B primers shown in Fig 7B. Method and kit for use in amplification and detection of rearrangements.

---

Inventions 9-25: claims 6,20,26,37-42 (partially)

Each invention concerns a set of primers comprising a forward primer binding to one of Vbeta5 etc to Vbeta24 and a reverse primer selected from the JbetaA and JbetaB primers shown in Fig 7B. Method and kit for use in amplification and detection of rearrangements.

---

Invention 26: claims 7,27 (completely), 20,37-42 (partially)

A set of primers comprising a forward primer binding to Dbeta and a reverse primer selected from the JbetaA and JbetaB primers shown in Fig 7B. Method and kit for use in amplification and detection of rearrangements.

---

Invention 27: claims 8,28 (completely), 20,37-42 (partially)

A set of primers comprising a forward primer binding to Vgamma and a reverse primer selected from the Jgamma primers shown in Fig 8B. Method and kit for use in amplification and detection of rearrangements.

---

Invention 28: claims 9-12,29-32 (completely), 20,37-42 (partially)

A set of primers capable of amplifying TCRD rearrangements comprising a forward primer and a reverse primer binding to Vdelta, Ddelta or Jdelta shown in Fig 9B. Method and kit employing the primers for use in amplification and detection of rearrangements.

---

Invention 29: claims 13,33 (completely), 20,37-42 (partially)

A set of primers comprising a forward and a reverse primer binding to BCL1/MTC as shown in Fig.10A. Method and kit employing the primers for use in amplification and detection of rearrangements.

---

Invention 30: claims 14,34 (completely), 20,37-42 (partially)

A set of primers comprising a forward primer binding to MBR and a reverse primer binding to the JH consensus sequence as defined in Fig.11A. Method and kit employing the primers for use in amplification and detection of rearrangements.

---

Invention 31: claims 15 (completely), 35-36 (partially)

Sets of primers for amplification of human TBXAS1, RAG1, PLZF and exon3 and exon 11 of AF4 as defined in Fig.12A and method of using the primers for assessing the quality of a DNA sample.

---

Invention 32: claims 16 (completely), 35-36 (partially)

Sets of primers for amplification of human RAG1 as defined in Fig.12A and method of using the primers for assessing the quality of a DNA sample.

---

Invention 33: claims 17 (completely), 35-36 (partially)

Sets of primers for amplification of human PLZF as defined in Fig.12A and method of using the primers for assessing the quality of a DNA sample.

---

Invention 34: claims 18-19 (completely), 35-36 (partially)

Sets of primers for amplification of exon3 and exon 11 of human AF4 as defined in Fig.12A and method of using the primers for assessing the quality of a DNA sample.

---

# INTERNATIONAL SEARCH REPORT

national Application No

T/NL 03/00690

Patent document cited in search report	Publication date	Patent family member(s)	Publication date
WO 0200848	A	03-01-2002	AU 8033401 A 08-01-2002
			CA 2413916 A1 03-01-2002
			EP 1303586 A1 23-04-2003
			JP 2004506414 T 04-03-2004
			US 0200848 A1 03-01-2002
			US 2002150928 A1 17-10-2002
US 6312690	B1	06-11-2001	FR 2724182 A1 08-03-1996
			CA 2198935 A1 14-03-1996
			EP 0778891 A1 18-06-1997
			WO 9607740 A1 14-03-1996
US 5472693	A	05-12-1995	AU 679046 B2 19-06-1997
			AU 6242694 A 14-09-1994
			CA 2155934 A1 01-09-1994
			EP 0684994 A1 06-12-1995
			JP 8510376 T 05-11-1996
			SG 45370 A1 16-01-1998
			WO 9419466 A2 01-09-1994
			US 5808033 A 15-09-1998
			WO 0022111
CA 2346927 A1 20-04-2000			
EP 1117774 A1 25-07-2001			
WO 0022111 A1 20-04-2000			
JP 2002527060 T 27-08-2002			
US 2003108889 A1 12-06-2003			
US 2003087236 A1 08-05-2003			
WO 0028086	A	18-05-2000	AU 2021400 A 29-05-2000
			WO 0028086 A1 18-05-2000